

HANDBOOK  
ON OVERHEAD  
LINE CONSTRUCTION

OK-  
AD  
T80

# HANDBOOK ON OVERHEAD LINE CONSTRUCTION

---

COMPILED BY THE  
SUB-COMMITTEE ON OVERHEAD LINE CONSTRUCTION  
NATIONAL ELECTRIC LIGHT ASSOCIATION

---

## *Sub-Committee*

THOMAS SPROULE, Chairman  
PAUL SPENCER                      R. D. COOMBS                      W. T. OVIATT  
FARLEY OSGOOD                      J. E. KEARNS  
N. E. STUNK, Secretary

---

PRESENTED AT THE THIRTY-SEVENTH CONVENTION  
NATIONAL ELECTRIC LIGHT ASSOCIATION  
HELD AT PHILADELPHIA, PENNSYLVANIA  
JUNE 1-5, 1914

11-11-14

Copyright, 1914  
National Electric Light Association

TO THE  
ASSOCIATION



FRANKLIN PRINTING COMPANY  
PHILADELPHIA

PUBLISHED BY ORDER OF THE

# National Electric Light Association

NEW YORK CITY

---

## OFFICERS

JOSEPH B. McCALL

President

Philadelphia, Pa.

JOHN A. BRITTON

Vice President, San Francisco, Cal.

HOLTON H. SCOTT

Vice President, New York

E. W. LLOYD

Vice President, Chicago, Ill.

E. C. DEAL

Vice President, Augusta, Ga.

T. COMMERFORD MARTIN

Secretary, New York

S. A. SEWALL

Assistant to Secretary, New York

W. F. WELLS

Treasurer, Brooklyn, N. Y.

H. BILLINGS

Asst. Sec'y and Treas., New York

EVERETT W. BURDETT

General Counsel, Boston, Mass.

GEORGE W. ELLIOTT

Master of Transp'tion, New York

---

## EXECUTIVE COMMITTEE

JOSEPH B. McCALL

H. C. ABELL

HENRY G. BRADLEE

JOHN A. BRITTON

E. C. DEAL

CHARLES L. EDGAR

W. C. L. EGLIN

A. C. EINSTEIN

H. L. BLEECKER

President Northwest Association

DUNCAN T. CAMPBELL

President Pennsylvania Section

R. E. LEE

President Iowa Electrical Association

W. F. GORENFLO

President Mississippi Section

H. A. HOLDREGE

President Nebraska Section

H. W. PECK

President Eastern New York Section

T. I. JONES, Chairman Commercial Section

C. E. GROESBECK

E. W. LLOYD

R. S. ORR

W. N. RYERSON

HOLTON H. SCOTT

FRANK M. TAIT

ARTHUR WILLIAMS

T. W. PETERS

President Southeastern Section

C. W. ROGERS

President New Hampshire Section

H. C. STERLING

President Michigan Section

D. R. STREET

President Canadian Association

C. C. WELLS

President New England Section

W. W. FREEMAN

Chairman Hydro-Electric Section

297667

## TABLE OF CONTENTS

Section	Page
1. An Abridged Dictionary of Electrical Words, Terms and Phrases.....	1
Logarithmic Tables, Trigonometric Tables. Decimal Equivalent Tables, Tables of Circumferences and Areas of Circles, Units and Conversion Tables.	
2. Distribution and Transmission Line Supports.....	107
3. Conductors and Wire Tables.....	171
4. Cross-Arms, Pins and Pole Line Hardware.....	263
5. Insulators.....	285
6. Transformers and Induction Regulators. Lightning Phenomena in Connection with Electric Circuits, Protective Apparatus, Grounding, Etc.....	315
7. Systems of Distribution and Transmission, Electrical Calculations.....	435
8. Mechanical Calculations of Transmission and Distribution Lines.....	519
9. Preservative Treatment of Poles and Cross-Arms.....	561
10. Primary and Secondary Line Construction.....	675
11. Meteorological Data, General Data and Rules for Resuscitation from Electric Shock.....	750

## *Preface*

**T**HE purpose of this Handbook is the presentation, in one volume, of descriptions of the methods and the materials employed in overhead line construction, and a tabulation of the necessary formulæ for the electrical and mechanical solutions of various transmission and distribution problems.

While many handbooks hitherto have been prepared covering these various branches of engineering, this, we believe, is the first attempt made to compile a work strictly on overhead line construction.

Literature on the subject is comparatively scarce and that which is available is distributed through a great number of publications. It has therefore been felt by almost all who have taken an active interest in overhead line construction that a handbook would be extremely useful. The preparation of this book has involved the collection of the available data and selection from these data what were most essential.

It is not the intention, and it must not be so considered, that this is a handbook of rules and regulations; or that an attempt has been made to create standards or write specifications. It is rather a collection of useful information, which should prove of material assistance to all those engaged in the construction or maintenance of overhead lines for light and power purposes. The authorship of such specifications as have been included is specially noted. The formulæ used have been taken from authoritative sources, and while the Sub-Committee is not responsible for them, it believes they will be found of service.

It must be expected there will be found omissions of matter which should have been added; and material may be included which later may prove of little value. It is

## Preface

hoped, however, that users of this Handbook will assist future committees by offering suggestions, additions or corrections for use in later editions.

In the treatment of apparatus, efforts have been made to describe the various types at present on the market. It has been necessary to quote extensively from manufacturers' literature; and, in illustrating types of devices, to select those marketed by a limited number of manufacturers. **This is not intended either as an endorsement of such apparatus, or as a condemnation of apparatus not illustrated or described.** In the majority of cases, selections were made because of the availability of the information.

The compilation of the data for this Handbook has been carried out by the secretary of the Sub-Committee, Mr. N. E. Funk, of The Philadelphia Electric Company, to whom belongs the greatest share of credit for what has been accomplished in the preparation of this work. Mr. Funk was detailed by that Company to devote all of his time to this subject, under the direction of the Chairman of the Sub-Committee, who desires to take this opportunity to express his appreciation of the amount of thought and judgment given to the work.

We also wish to acknowledge the assistance which we have received wherever asked, and especially to Professor Charles F. Marvin, *Chief*, Professor William J. Humphreys and Mr. George S. Bliss, all of the United States Weather Bureau, who have cooperated in the compilation of the chapter on "Meteorology," which is the first attempt ever made to tabulate such data for publication in a handbook.

The Section on the "Preservative Treatment of Poles and Cross-Arms" is a reprint of the 1910 and 1911 Reports of the National Electric Light Association Committee appointed to consider this subject. These reports have

## Preface

been combined by Mr. W. K. Vanderpoel, of the Public Service Electric Company, whose efforts are gratefully acknowledged.

The available information on "Pole Timber Logging and Pole Timber Defects" is meager; much of the data that are included has been secured through the coöperation of Mr. O. T. Swan, of the Forestry Service, U. S. Bureau of Agriculture, and Mr. F. L. Rhodes, of the American Telephone and Telegraph Company, and this also is gratefully acknowledged.

The ready coöperation of the various manufacturers, who contributed for publication much valuable information many photographs and cuts, is hereby acknowledged.

Grateful acknowledgment is also made particularly to Mr. J. C. Parker, of the Rochester Railway and Light Company Mr F L Rhodes, of the American Telephone and Telegraph Company, Mr. S. M. Viele, of the Pennsylvania Railroad Company, Mr. J. E. Kearns, of the General Electric Company, Mr. R. D. Coombs, of R. D. Coombs and Company, Mr. E. G. Reed, of the Westinghouse Electric Company and also to Mr. W. C. L. Eglin, Mr. George Ross Green, Mr. Horace P. Liversidge, Mr. Charles Penrose, Mr. J. V. Matthews, Mr. W. L. Robertson, Mr. Alexander Wilson, 3rd and Mr. Robert A. Hentz, all of The Philadelphia Electric Company; and to representatives of the many manufacturing companies for their assistance in checking over the various parts of the Handbook.

In the first edition of any handbook embracing so large a subject, errors undoubtedly will be made. These will be corrected in future editions and we would ask our readers to send all criticisms to the secretary of the Association so that they can be referred to those responsible for the revision of the Handbook. In this connection,



## Preface

consideration should be given to the broadening of the scope of the Handbook, and to the question as to whether it should include transmission line construction, underground construction, maintenance and methods of keeping accurate records of outdoor apparatus, etc. These and other important questions must receive the attention of future committees, and it will be extremely helpful to these committees to obtain the advice and assistance of the membership at large.

In conclusion, we desire to express our appreciation to the present officers and Executive Committee of the National Electric Light Association, particularly to its president, Mr. Joseph B. McCall, through whose personal efforts the preparation and publication of the Handbook have been made possible.

It is our earnest hope that this Handbook may prove of service to the industry; this has been the controlling thought throughout its preparation.

SUB-COMMITTEE ON HANDBOOK

THOMAS SPROULE, *Chairman*

PHILADELPHIA, JUNE 1, 1914

# **SECTION 1**

## **AN ABRIDGED DICTIONARY OF ELECTRICAL WORDS, TERMS AND PHRASES**

---

### **TABLES**

**INCLUDING LOGARITHMIC TABLES, TRIGONO-  
METRIC TABLES, DECIMAL EQUIVALENT  
TABLES, TABLES OF CIRCUMFERENCES  
AND AREAS OF CIRCLES, UNITS  
AND CONVERSION TABLES**



## A.

**A. C.** An abbreviation for alternating current.

**ABSOLUTE TEMPERATURE.** That temperature which is reckoned from the absolute zero,  $-273^{\circ}$  C. or  $-459^{\circ}$  F.

**ADMITTANCE.** The reciprocal of the impedance in an alternating-current circuit. The apparent conductance of an alternating-current circuit or conductor.

**AERIAL CABLE.** An insulated cable protected by a metallic sheath and suspended from a messenger cable which is usually grounded.

**AERIAL CONDUCTOR.** An overhead conductor.

**AGEING OF TRANSFORMER CORE.** Increase in the hysteresis coefficient in the iron of a transformer core during its commercial operation, from its continued magnetic reversals at comparatively high temperature.

**AIR-CORE TRANSFORMER.** A transformer which is void of a core other than that of air.

**AIR-GAP.** In a magnetic circuit, any gap or opening containing air only.

**AIR-PATH.** The path a disruptive discharge takes through the air.

**AIR-RELUCTANCE.** The reluctance of that portion of a magnetic circuit which consists of air.

**ALTERNATION.** An oscillation of an electric or magnetic wave from a zero to a maximum value and back to zero again, a half of a cycle. (See cycle.)

**ALTERNATING CURRENT** is a current which alternates regularly in direction. Unless distinctly otherwise specified, the term "alternating current" refers to a periodic current with successive half waves of the same shape and area.

An alternating current equals the electromotive force divided by the impedance, or

$$I = \frac{E}{Z} = \frac{E}{\sqrt{R^2 + X^2}}$$
$$I = \frac{E}{\sqrt{R^2 + \left(\omega L - \frac{1}{\omega C}\right)^2}}$$

This expression may be solved by complex quantities or vectorially.

$Z = \sqrt{R^2 + X^2}$ , Impedance of circuit

$R =$  Ohmic resistance of circuit

$X =$  Reactance of circuit in Ohms  $= \left( \omega L - \frac{1}{\omega C} \right)$

$L =$  Coefficient of self-induction in henrys

$C =$  Capacity of the circuit in farads

$\omega = 2\pi f$ , angular velocity, where

$f =$  the number of cycles per second or frequency.

**ALTERNATING CURRENT POWER.** The power expended in an alternating current circuit at any given instant in the cycle is equal to the product of the **voltage** and **current** at that instant. When the voltage and current reverse at the **same instant**, this product is always **positive**, and if their wave forms are **alike**, the power expended is a **maximum**, and is equal to the product of the **effective values of voltage and current**. Such voltages and currents are in **phase**. When the term "power expended in an alternating current circuit" is used, the **average value** during one cycle is ordinarily meant.

**ALTERNATION, PERIODICITY OF.** The time required for the current to pass through one cycle. When any particular periodicity or frequency is spoken of, as for example, **250 alternations** per second, **125 complete periods or cycles** per second are meant.

**ALUMINUM.** A soft, ductile, malleable metal of white color approaching silver, but with a bluish cast. Does not readily oxidize. Melts at a low temperature. Cannot readily be welded, or brazed or soldered. Very **electro-positive**, and is eaten away in presence of salts and other metals. Atomic weight 27.1. **Specific gravity 2.6 to 2.7.** The lightest of all useful metals next to magnesium. Expands greatly with increasing temperature. For equal conductivity, aluminum has about one-half the weight of copper. Tenacity about one-third that of wrought-iron.

**AMERICAN WIRE GAUGE.** The name generally given to the Brown and Sharpe wire gauge, in which the large wire No. 0000, has a diameter of 0.46", the wire No. 36, 0.005", and all other diameters are in geometrical progression.

It will be seen upon examining a wire table that an increase of **three** in the wire number corresponds to doubling the **resistance** and halving the **cross-section** and weight. Also, that an increase of **ten** in the wire number increases the **resistance ten times** and diminishes the **cross-section** and weight to **one-tenth** their original values.

The **American Steel and Wire gauge** is used almost universally in this country for steel and iron wires.

The **Birmingham gauge** is used largely in England as their standard, and in this country for steel wires and for other wires not used especially for electrical purposes.

**AMPERE.** The practical unit of electric current. A rate of flow of electricity transmitting one coulomb per second. The current of electricity which would pass through a circuit whose resistance is one ohm, under an electromotive force of one volt. A current of such a strength as will deposit 1.118 milligrammes of silver per second from a specifically prepared solution of silver nitrate.

The value of the ampere as adopted by the International Congress of 1893, at Chicago is equal to the one-tenth of a unit of current in the C.G.S. system of electric-magnetic units and represented with sufficient accuracy for practical purposes, by the unvarying current, which, when passed through a solution of nitrate of silver in water, in accordance with certain specifications, deposits silver at the rate of 0.001118 of a gramme-per-second.

**AMPERE HOUR.** A unit of electrical quantity equal to the quantity of electricity conveyed by one ampere flowing for one hour. A quantity of electricity equal to 3600 coulombs.

**AMPERE SECOND.** A unit of electric quantity equal to the quantity of electricity conveyed by one ampere flowing for one second. A coulomb.

**AMPERE TURN.** A unit of magneto-motive force equal to that produced by one ampere flowing around a single turn of wire.

**AMPLITUDE OF VIBRATION OF WAVE.** The extent of a movement measured from the starting point or position of equilibrium. The maximum voltage of a sine wave.

**ANCHOR LOG.** A log buried in the ground and serving as an anchor for a pole guy.

**ANGLE OF LAG OR LEAD OF CURRENT.** An angle whose tangent is equal to the ratio of the reactive to the ohmic resistance in a circuit; whose cosine is equal to the ohmic resistance divided by the impedance of a circuit; whose cosine is the ratio of the real to the apparent power in an alternating current circuit or the angle by which the current lags behind or leads the e.m.f.

**ANGULAR VELOCITY.** The velocity of a point moving relatively to a centre of rotation or to some selected point, and usually measured in degrees per second, or in radians per second. In a sinusoidal current circuit the product of 6.2832 and the frequency of the current.

**APPARENT EFFICIENCY.** The volt-ampere efficiency or the ratio of volt-ampere output to volt-ampere input. In apparatus in which a phase displacement is inherent to their operation, apparent efficiency should be understood as the ratio of net power output to volt-ampere input.

**APPARENT POWER.** In an alternating current circuit the product obtained by multiplying the mean effective value of the

## Sec. 1

## DICTIONARY

**e.m.f.** by the mean effective value of the current, such as read directly from a volt-meter and ammeter.

$\frac{\text{Power}}{\text{Power-factor}} = \text{apparent power}$ . When the power-factor is unity the apparent power in volt-amperes is equal to watts.

**APPARENT OR EQUIVALENT RESISTANCE.** Represents a counter e.m.f. which is in exact phase opposition with the current, i. e., in phase with the I R drop. These counter e.m.f.'s may be generated in motors or in transformers. Losses in the magnetic circuit such as hysteresis and secondary losses such as eddy currents may also be considered as forming part of the apparent resistance loss.

**ARMOR OF CABLE.** The protecting sheathing or metallic covering of a submarine or other electric cable.

**ASBESTOS.** A hydrous silicate of magnesia, i. e., silicate of magnesia combined with water. A fire-proofing material sometimes used by itself or in connection with other material for insulating purposes.

**AUTOMATIC CIRCUIT-BREAKER.** A device for automatically opening a circuit when the current passing through it is excessive.

**AUTOMATIC SWITCH.** A switch which is automatically opened or closed on the occurrence of certain predetermined events.

**AUTO-TRANSFORMER.** A one-coil transformer consisting of a choking coil connected across a pair of alternating-current mains, and so arranged that a current or pressure differing from that supplied by the mains can be obtained from it by tapping the coil at different points. Called also a compensator. A transformer in which a part of the primary winding is used as the secondary winding, or conversely.

**AXIS OF CO-ORDINATES.** A vertical and a horizontal line, usually intersecting each other at right angles, and called respectively the axes of ordinates and abscissas, from which the ordinates and abscissas are measured.

### B.

**B. & S. G.** An abbreviation for Brown and Sharpe's Wire Gauge.

**B. W. G.** An abbreviation for Birmingham Wire Gauge.

**BALANCED CIRCUIT.** A circuit which has been so erected and adjusted as to be free from mutual inductive disturbances from neighboring circuits.

**BALANCED LOAD OF SYSTEM.** Any system is said to be balanced when all conditions of each of the circuits of a polyphase, or n-wire, system are alike and numerically equal.

**BARROW-REEL.** A reel supported on a barrow for convenience in paying out an overhead conductor during its installation.

**BEG-OHMS.** One billion ohms, or one thousand megohms.

**BICRO.** A prefix for one-billionth, one thousand millionth.

**BIGHT OF CABLE.** A single loop or bend of cable.

**BIMETALLIC WIRE.** A compound wire consisting of a steel core and a copper envelope.

**BLOWING A FUSE.** The fusion or volatilization of a fuse wire or safety strip by the current passing through it.

**BLOWING POINT OF FUSE.** The current strength at which a fuse blows or melts.

**BRAIDED WIRE.** A wire covered with a braiding of insulating material.

**BRANCH CIRCUITS.** Additional circuits provided at points of a circuit where the current branches or divides, part of the current flowing through the branch, and the remainder flowing through the original circuit. A shunt circuit.

**BRANCH CUT-OUT.** A safety fuse or cut-out, inserted between a pair of branch wires and the mains supplying them.

**BREAKING DOWN OF INSULATION.** The failure of an insulating material, as evidenced by the disruptive passage of an electric discharge through it.

**BRITANNIA JOINT.** A joint in which the ends of the wires are laid side by side bound together, and subsequently soldered.

**BRONZE.** An alloy of copper and tin.

**BRUSH AND SPRAY DISCHARGE.** A streaming form of high potential discharge possessing the appearance of a spray of silvery white sparks, or of a branch of thin silvery sheets around a powerful brush. Obtained by increasing the frequency of the alternations.

**BRUSH DISCHARGE.** The faintly luminous discharge which takes place from a positive charged pointed conductor.

**BUNCHEd CABLE.** A cable containing more than a single wire or conductor.

C.

C. An abbreviation for Centigrade.

C. A symbol used for capacity. Farad.

The defining equation is  $C = \frac{Q}{E}$

The same symbol is often used for current.



**c.c.** An abbreviation for cubic centimeter, the C.G.S. unit of volume.

**cm.** An abbreviation for centimeter, the C.G.S. unit of length.

**C. G. S. UNITS.** An abbreviation for centimeter, gram, second units. The metric system of units for measuring length, mass and time.

**CABLE.** A stranded conductor (single-conductor cable); or a combination of conductors insulated from one another (multiple-conductor cable).

**CABLE CASING.** The metallic sheathing of a cable.

**CABLE CORE.** The hemp or steel center of an aerial electrical cable to enlarge the cross section of the cable or to carry the mechanical strain of the conductors.

**CABLE DUPLEX.** Two insulated single-conductor cables twisted together.

**CABLE GRIP.** The grip provided for holding the end of an underground cable while it is being drawn into a duct.

**CABLE HOUSE.** A hut provided for securing and protecting the end of a cable.

**CABLE, SUBMARINE.** A cable designed for use under water.

**CABLE VAULT.** A vault provided in a building where cables enter from underground conduits and where the cables are opened and connected to fusible plugs or safety catches.

**CALORIE.** A heat unit. The quantity of heat required to raise 1 gramme of water 1° centigrade.

**CAP WIRE.** An overhead wire carried on the summit of a pole, as distinguished from an overhead wire carried on a crossarm.

**CAPACITY, ELECTROSTATIC.** The quantity of electricity which must be imparted to a given body or conductor as a charge, in order to raise its potential a certain amount. (See Potential Electric.)

The electrostatic capacity of a conductor is not unlike the capacity of a vessel filled with a liquid or gas. A certain quantity of liquid will fill a given vessel to a level dependent on the size or capacity of the vessel. In the same manner a given quantity of electricity will produce, in a conductor or condenser a certain difference of electric level, or difference of potential, dependent on the electrical capacity of the conductor or condenser.

In the same manner, the smaller the capacity of a conductor, the smaller is the charge required to raise it to a given potential, or the higher the potential a given charge will raise it.

The capacity  $C$ , of a conductor or condenser, is therefore directly proportional to the charge  $Q$ , and inversely proportional to the potential  $E$ ; or,

$$C = \frac{Q}{E}$$

from which we obtain  $Q = CE$ .

The quantity of electricity required to charge a conductor or condenser to a given potential is equal to the capacity of the conductor or condenser multiplied by the potential through which it is raised.

**CAPACITY, ELECTROSTATIC, UNIT OF.** The farad. Such a capacity of a conductor or condenser that an electromotive force of one volt will charge it with a quantity of electricity equal to one coulomb.

**CAPACITY OF CABLE.** The quantity of electricity required to raise a given length of cable to a given potential, divided by the potential. The ability of a conducting wire or cable to permit a certain quantity of electricity to be passed into it before acquiring a certain potential.

**CAPACITY OF LINE.** The ability of a line to act as a condenser, and, therefore, like it, to possess capacity.

**CAPACITY REACTANCE.** The property by which a counter e.m.f. is produced when an e.m.f. is impressed across the terminals of two conducting surfaces separated by a dielectric.

**CARBON.** An elementary substance which occurs naturally in three distinct allotropic forms: graphite, charcoal and the diamond.

**CARRYING CAPACITY.** The maximum current strength that any conductor can safely transmit.

**CATENARY CURVE.** The curve described by the sagging of a wire, under its own weight, when stretched between two points of support.

**CENTIGRAMME.** The hundredth of a gramme; or, 0.1543 grain avoirdupois.

**CENTIMETER.** The hundredth of a metre; or 0.3937 inch.

**CENTIMETER-GRAMME-SECOND SYSTEM.** A system based on the centimeter as the unit length, the gramme as the unit of mass, and the second as the unit of time.

**CENTER OF DISTRIBUTION.** Is the point from which the electrical energy must be supplied to use a minimum weight of conducting material.

**CHARACTERISTIC CURVE.** A diagram in which a curve is employed to represent the relation of certain varying values. A curve indicating the characteristic properties of a dynamo-electric machine under various phases of operation. A curve indicating the electromotive force of a generator, as a variable dependent on the excitation.

**CHARGE, ELECTRIC.** The quantity of electricity that exists on the surface of an insulated electrified conductor.

**CHOKER COIL.** A reactance used in alternating current circuits for the adjustment of voltage and power factor; and also to impede high frequency oscillations such as lightning discharges in both direct current and alternating current circuits.

**CIRCUIT BREAKER.** Any device for opening or breaking a circuit.

**CIRCUIT, ELECTRIC.** The path in which electricity circulates or passes from a given point, around or through a conducting path, back again to its starting point.

All simple circuits consist of the following parts, viz:

- (1) Of an electric source which may be a voltaic battery, a thermopile, a dynamo-electric machine, or any other means for producing electricity.
- (2) Of leads or conductors for carrying the electricity out from the source, through whatever apparatus is placed in the line, and back again to the source.
- (3) Various electro-receptive devices, such as electro-magnets, electrolytic baths, electric motors, electric heaters, etc., through which passes the current by which they are actuated or operated.

**CIRCUIT MULTIPLE.** A circuit in which a number of separate sources or separate electro-receptive devices or both, each have one of their poles connected to a single lead or conductor and their other poles connected to another single lead or conductor.

**CIRCUIT, OPEN.** A broken circuit. A circuit, the conducting continuity of which is broken.

**CIRCUIT, PARALLEL.** A name sometimes applied to circuits connected in multiple.

**CIRCUIT, SERIES.** A circuit in which the separate sources or the separate electro-receptive devices, or both, are so placed that the current produced in each, or passing through each, passes successively through the entire circuit from the first to the last.

**CIRCULAR MIL.** A unit of area employed in measuring the cross-section of wires, equal, approximately, to 0.7854 square mils. The area of a circle one mil in diameter.

**CLOCKWISE MOTION.** A rotary motion whose direction is the same as that of the hands of a clock, looking at the face.

**COEFFICIENT OF EXPANSION.** The coefficient of linear expansion of a solid is the increase in length of unit length when the temperature is raised from 32 to 33 degrees Fah. or from 0 to 1 degree Cent.

The coefficient of cubical expansion is the increase in volume of a

body when its temperature is raised from 32 to 33 degrees Fah. or from 0 to 1 degree Cent., divided by its original volume.

**COEFFICIENT OF HYSTERESIS.** The work expended hysteretically in a cubic-centimetre of iron, or other magnetic substance, in a single cycle, at unit magnetic flux density. The coefficient which multiplied by the volume of iron, the frequency of alternation, and the 1.6th power of the maximum flux density gives the hysteretic power loss.

**COEFFICIENT OF INDUCTANCE.** A constant quantity such that, when multiplied by the current strength passing through any coil or circuit, will numerically represent the flux linkage with that coil or circuit due to that current. A term sometimes used for coefficient of self-induction. The ratio of the counter e.m.f. of self-induction in a coil or circuit to the time-rate-of-change of the inducing current.

**COEFFICIENT OF MUTUAL INDUCTANCE.** The ratio of the electromotive force induced in a circuit to the rate-of-change of the inducing current in a magnetically associated circuit. The ratio of the total flux-linkage with a circuit proceeding from an associated inducing circuit, to the strength of current flowing in the latter.

**COEFFICIENT OF SELF-INDUCTANCE.** Self-inductance. The ratio in any circuit of the flux induced by and linked with a current, to the strength of that current. The ratio in any circuit of the e.m.f. of self-induction to the rate-of-change of the current.

**COME ALONG.** A small portable vise capable of ready attachment to an aerial line or cable, and used to pull the wire to its proper tension.

**COMMON RETURN.** A return conductor common to several circuits.

**COMPENSATOR.** An auto-transformer.

**COMPLETE WAVE.** Two successive alternations or a double alternation of a periodically-alternating quantity. A cycle.

**COMPONENTS OF IMPEDANCE.** The energy component or effective resistance and the wattless component or effective reactance.

**COMPOSITE WIRE.** A wire provided with a steel core and an external copper sheath, possessing sufficient tensile strength to enable it to be used in long spans without excessive sagging. A bimetallic wire.

**COMPOUND.** An asphaltic composition employed in the sheathing of submarine cables. A term often applied to insulating materials.

**CONCENTRIC CABLE.** A cable provided with both a leading and return conductor insulated from each other, and forming re-

## Sec. 1

## DICTIONARY

spectively the central core or conductor, and the enclosing tubular conductor. A cable having concentric conductors.

**CONDENSANCE.** Capacity reactance.

**CONDENSER.** A device composed of two or more conducting bodies separated by a dielectric.

**CONDENSER CAPACITY.** The capacity of a condenser. (See Capacity.)

**CONDUCTANCE.** A word sometimes used in place of conducting power. The reciprocal of resistance. In a continuous-current circuit the ratio of the current strength to the e.m.f.; in an alternating current circuit the quantity by which the e. m. f. is multiplied to give the component of the current in phase with the e. m. f.

**CONDUCTIVITY, ELECTRIC.** The reciprocal of electric resistivity. The conductance of a substance referred to unit dimensions.

**CONDUCTOR.** Any substance which will permit the so-called passage of an electric current. A substance which possesses the ability of determining the direction in which electric energy shall pass through the ether in the dielectric surrounding it.

**CONNECTING SLEEVE.** A metallic sleeve employed as a connector for readily joining the ends of two or more wires.

**CONNECTION, MULTIPLE.** Such a connection of a number of separate electric sources, or electro-receptive devices, or circuits, that all the positive terminals are connected to one main or positive conductor, and all the negative terminals are connected to one main or negative conductor.

**CONNECTION, SERIES.** The connection of a number of separate electric sources, or electro-receptive devices, or circuits, so that the current passes successively from the first to the last in the circuit.

**CONSTANT.** A quantity used in a formula, the value of which remains the same, regardless of the value of the other quantities used in the formula.

**CONSTANT CURRENT.** A current maintained at a constant effective value in a circuit is known as a constant current. This may be either alternating or direct current.

**CONSTANT-CURRENT TRANSFORMER.** A transformer which is intended to raise or reduce a current strength in a given constant ratio. A transformer designed to maintain a constant strength of current in its secondary circuit, despite changes of load.

**CONSTANT-POTENTIAL CIRCUIT.** A circuit whose potential is maintained approximately constant. A multiple-arc or parallel connected circuit.

**CONTINUOUS CURRENT.** An electric current which flows in one and the same direction. A steady or non-pulsating direct current.

**CONVECTION CURRENTS.** Currents produced by the bodily carrying forward of static charges in convection streams.

**CONVECTIVE DISCHARGE.** The discharge which occurs from the points of a highly charged conductor, through the electrostatic repulsion of similarly charged air particles, which thus carry off minute charges.

**CO-PERIODIC.** Possessing the same periodicity.

**CO-PHASE.** Coincidence in phase of co-periodic motions. Such a phase relation between two periodic but non-co-periodic quantities as tends to increase the amplitude of the motion.

**COPPER, Cu.** Atomic weight 63.2, specific gravity 8.81 to 8.95. Fuses at about 1930° F. Distinguished from all other metals by its reddish color. Very ductile and malleable and its tenacity is next to iron. Tensile strength 20,000 to 30,000 lbs. per square inch. Heat conductivity 73.6% of that of silver and superior to that of other metals. Expands 0.0051 of its volume by heating from 32° to 212° F.

**COPPER LOSS.** The total loss of energy produced by the passage of a current through the copper wire of a dynamo, motor, or conducting system generally. The loss of energy due to the resistance of the conductor to the passage of the current. This loss is equal to the resistance of the conductor times the square of the effective current flowing in the conductor.

**CORE, LAMINATION OF.** Structural subdivisions of the cores of magnets, transformers, or similar apparatus, in order to prevent heating and subsequent loss of energy from the production of local eddy or Foucault currents.

These laminations are obtained by forming the cores of sheets, rods, plates, or wires of iron insulated from one another.

**CORE LOSSES.** The hysteresis and the Foucault or eddy-current losses of the core of a dynamo, motor or transformer.

**CORONA.** The name given to a brush discharge surrounding arial conductors which carry high potential. The discharge is red violet in color, gives a hissing sound and is probably intermittent in character.

**COSINE.** One of the trigonometrical functions. The ratio of the base to the hypotenuse of a right-angled triangle in which the hypotenuse is the radius vector, and the angle between the base and hypotenuse the angle whose cosine is considered.

## Sec. 1

## DICTIONARY

**COTANGENT.** The ratio of the adjacent side to the opposite side of an angle of a right triangle. Cotangent  $\theta = \frac{1}{\text{tangent } \theta}$ .

**COULOMB.** The practical unit of electric quantity. Such a quantity of electricity as would pass in one second through a circuit conveying one ampere.

The quantity of electricity contained in a condenser of one farad capacity, when subjected to the e.m.f. of one volt.

The value of the coulomb as adopted by the International Electrical Congress of 1893, at Chicago. The quantity of electricity equal to that transferred through a circuit by a current of one international ampere in one second.

The quantity of electricity which if concentrated at a point and placed at one centimeter from an exactly similar quantity will repel the latter with a force of one dyne.

**COUNTER-ELECTROMOTIVE FORCE.** An opposite or reverse electromotive force which tends to set up a current in the opposite direction to that actually produced by a source.

**COUNTER-ELECTROMOTIVE FORCE OF INDUCTION.** The counter-electromotive force of self or mutual induction.

**COUPLE.** In mechanics, two equal and parallel, but oppositely directed forces, not acting in the same line, and tending to produce rotation.

**CROSS ARM.** A horizontal beam attached to a pole for the support of the insulators of electric light, or other electric wires.

**CROSS, ELECTRIC.** A connection, generally metallic, accidentally established between two conducting lines. A defect in an electric circuit, caused by two wires coming into contact by crossing each other.

**CURRENT DISTRIBUTION.** The density of electric currents in the various parts of a conducting mass or net work.

**CURRENT DETERMINATION FROM WATTAGE.** The rated current may be determined as follows: If  $W$  = rating in watts, or apparent watts, if the power-factor be other than 100 per cent, and  $E$  = full-load terminal voltage, the rated current per terminal is:

$$I = \frac{W}{E} \text{ in continuous current, or single-phase apparatus}$$

$$I = \frac{W}{\sqrt{3} E} \text{ in three-phase apparatus}$$

$$I = \frac{W}{2 E} \text{ in two-phase four wire apparatus.}$$

**CURRENT, ELECTRIC.** The quantity of electricity per second which passes through any conductor or circuit, when the flow is

uniform. The **rate** at which a quantity of electricity flows or passes through a circuit. The ratio, expressed in terms of electric quantity per second, existing between the **electromotive force** causing a current and the **resistance** which opposes it.

The **unit** of current, or the **ampere**, is equal to one **coulomb** per second. (See **Ampere**, and **Coulomb**.)

The word **current** must not be confounded with the mere act of flowing; electric current signifies **rate of flow**, and always supposes an **electromotive force** to produce the current, and a **resistance** to oppose it.

The electric current is assumed to flow out from the **positive** terminal of a source, through the circuit and back into the source at the **negative** terminal. It is assumed to flow into the positive terminal of an electro-receptive device such as a lamp, motor, or storage battery, and out of its negative terminal; or, in other words, the **positive** pole of the source is always connected to the **positive** terminal of the electro-receptive device.

The current that flows or passes in any circuit is, in the case of a constant current, equal to the **electromotive force**, or difference of potential, divided by the **resistance**, as:

$$\begin{array}{l} \text{D. C.} \\ I = \frac{E}{R} \end{array}$$

$$\begin{array}{l} \text{A. C.} \\ I = \frac{E}{Z} \end{array}$$

The flow of an electric current may vary in any manner whatsoever.

A current which continues flowing in the same direction no matter how its strength may vary, is called a **direct current**. If the strength of such a current is constant, it is called a **continuous current**. A regular varying continuous current is called a **pulsatory current**. A current which alternately flows in opposite directions, no matter how its strength may vary, is called an **alternating current**. This may be **periodic** or **non-periodic**.

**CURRENT, FOUCAULT.** A name sometimes applied to **eddy currents**, especially in armature cores.

**CURRENT, POLYPHASE,** is the general term applied to any system of more than a single phase.

**CURRENT RUSH.** The initial flow of electricity that occurs when a transformer, transmission line or other electrical apparatus is switched on or connected to an electric circuit.

**CURRENT, SIMPLE PERIODIC.** A current, the flow of which is variable both in strength and duration, but recurring at definite intervals. A flow of current passing any section of a conductor that may be represented by a simple harmonic curve.

**CURRENT STRENGTH.** In a direct-current circuit the quotient of the total **electromotive force** divided by the total **resistance**. The time-rate-of-flow in a circuit expressed in amperes, or coulombs



per second. In an alternating current the quotient of the total electromotive force divided by the impedance.

**CUT-OUT.** A device for removing an electro-receptive device or loop from the circuit. A safety fuse.

**CUT-OUT-BLOCK.** A block containing a fuse wire or safety catch.

**CUT-OUT-SWITCH.** A short-circuiting switch by means of which an arc-light or series loop is cut out from its feeding circuit.

**CYCLE.** One complete set of positive and negative values of an alternating current.

## D.

**D. C.** An abbreviation for direct current.

**D. P. SWITCH.** An abbreviation for double-pole switch.

**DEAD MAN.** A support for raising a pole and supporting it in place while securing it in the ground.

**DELTA-CONNECTION.** The connection of circuits employed in a delta three phase system.

**DELTA THREE PHASE SYSTEM.** A three phase system in which the terminal connections resemble the Greek letter delta, or a triangle.

**DEMAND.** Demand is a load specified, contracted for or used, expressed in terms of power as kilowatts or horse-power.

**DEMAND FACTOR.** Unless otherwise specified, demand factor is the maximum connected kilowatts of capacity divided into the actual kilowatts of demand, and expressed in terms of percent.

**DENSITY.** Mass of unit volume, compactness.

**DENSITY OF CURRENT.** The quantity of current that passes per-unit-of-area of cross-section in any part of a circuit.

**DENSITY OF FIELD.** The quantity of magnetic flux that passes through any field per-unit-of-area of cross-section.

**DIELECTRIC.** Any substance which permits electrostatic induction to take place through its mass.

The substance which separates the opposite coatings of a condenser is called the dielectric. All dielectrics are non-conductors.

All non-conductors or insulators are dielectrics, but their dielectric power is not exactly proportional to their non-conducting power.

Substances differ greatly in the degree or extent to which they permit induction to take place through or across them.

A dielectric may be regarded as pervious to rapidly reversed periodic currents, but opaque to continuous currents. There is, however, some conduction of continuous currents.

**DIELECTRIC CAPACITY.** A term employed in the same sense as specific inductive capacity.

**DIELECTRIC HYSTERESIS.** A variety of molecular friction, analogous to magnetic hysteresis, produced in a dielectric under charges of electrostatic stress. That property of a dielectric by virtue of which energy is consumed in reversals of electrification.

**DIELECTRIC RESISTANCE.** The resistance which a dielectric offers to strains produced by electrification. The resistance of a dielectric to displacement currents.

**DIELECTRIC STRAIN.** The strained condition of the glass or other dielectric of a condenser produced by the charging of the condenser. The deformation of a dielectric under the influence of an electro-magnetic stress.

**DIPPING.** An electro-metallurgical process whereby a thin coating or deposit of metal is obtained on the surface of another metal by dipping it in a solution of a readily decomposable metallic salt. Cleansing surfaces for electric-plating by immersing them in various acid liquors.

**DISCHARGE.** The equalization of the difference of potential between the terminals of a condenser or source, on their connection by a conductor. The removal of a charge from a conductor by connecting the conductor to the earth or to another conductor. The removal of a charge from an insulated conductor by means of a stream of electrified air particles.

**DISRUPTIVE DISCHARGE.** A sudden and more or less complete discharge that takes place across an intervening non-conductor or dielectric.

**DISRUPTIVE STRENGTH OF DIELECTRIC.** The strain a dielectric is capable of bearing without suffering disruption, or without permitting a disruptive discharge to pass through it.

**DISSIPATION OF ENERGY.** The expenditure or loss of available energy.

**DISTRIBUTED CAPACITY.** The capacity of a circuit considered as distributed over its entire length, so that the circuit may be considered as shunted by an infinite number of infinitely small condensers, placed infinitely near together, as distinguished from localized capacity, in which the capacity is distributed in definite aggregations.

**DISTRIBUTED INDUCTANCE.** Inductance distributed through the entire length of a circuit or portion thereof, as distinguished from inductance interposed in a circuit in bulk at some one or more points.

**DISTRIBUTING CENTER.** (See Center of Distribution.)

**DISTRIBUTING MAINS.** The mains employed in a feeder system of parallel distribution.

**DIVERSITY FACTOR.** A diversity factor is used to express the relation between the simultaneous demand of all individual consumers and the sum of the maximum demands made by these consumers; the sum of the maximum demands of the consumers for one year, no matter at what time they occurred, divided into the simultaneous greatest demand of these consumers for a like period, when expressed in percent will give the diversity factor.

**DRAW VISE.** A device employed in stringing overhead wires. A portable vise for holding and drawing up an overhead wire.

**DROP.** A word frequently used for drop of potential, pressure, or electromotive force. The fall of potential which takes place in an active conductor by reason of its resistance, or impedance.

**DROP OF POTENTIAL.** The fall of potential, equal in any part of a circuit to the product of the current strength and the resistance, or impedance of that part of the circuit.

**DROP OF VOLTAGE.** The drop or difference of potential of any part of a circuit.

**DUPLEX CABLE.** A cable containing two separate conductors placed parallel to each other.

**DUPLEX WIRE.** An insulated conductor containing two separately insulated parallel wires.

**DYNAMIC ELECTRICITY.** A term sometimes employed for the phenomena of the transfer of electric energy, in contradistinction to static electricity.

**DYNE.** The C.G.S. unit of force. The force which in one second can impart a velocity of one centimeter-per-second to a mass of one gramme.

## E.

**e. h. p.** An abbreviation for electrical horse-power.

**e. m. f.** An abbreviation for electromotive force.

**e. m. f. OF SELF-INDUCTION.** The e.m.f. generated in a loop of wire during the change of magnetic flux due to the current flowing therein.

**EARTH CIRCUIT.** A circuit in which the ground or earth forms part of the conducting path.

**EARTH CURRENTS.** Electric currents flowing through the earth, caused by the difference of potential of its different parts.

**EASEMENT.** A permit obtained from the owner of a property for the erection of poles or attachments for aerial lines.

**EDDY CURRENTS.** (See Foucault currents.)

**EFFECTIVE ELECTROMOTIVE FORCE.** The difference between the direct and the counter e.m.f. The square root of the mean square of the instantaneous values of a varying electromotive force. The value which is equivalent to a constant electromotive force.

**EFFECTIVE REACTANCE.** In an alternating-current circuit, the ratio of the wattless component of an electromotive force to the total current.

**EFFECTIVE RESISTANCE.** In an alternating-current circuit, the ratio between the energy component of an electromotive force and the total current.

**EFFICIENCY.** The efficiency of an apparatus is the ratio of its output to its input. The output and input may be in terms of watt-hours, watts, volt-amperes, amperes, or any other quantity of interest, thus respectively defining energy efficiency, power efficiency, apparent-power efficiency, current efficiency, etc. Unless otherwise specified, however, the term efficiency is ordinarily assumed to refer to power efficiency.

When the input and output are expressed in terms of the same unit, the efficiency is a numerical ration, otherwise it is a physical dimensional quantity.

**ELASTIC LIMIT.** This may be defined as that point at which the deformation ceases to be proportional to the stresses, or, the point at which the rate of stretch or other deformations begin to increase. It is also defined as the point at which permanent set becomes visible.

**ELECTRIFICATION.** The production of an electric charge.

**ELECTRO-CHEMISTRY.** That branch of electric science which treats of electric combinations and decompositions effected by the electric current. The science which treats of the relation between the laws of electricity and chemistry.

**ELECTRO-MAGNETIC UNITS.** A system of C.G.S. units employed in electro-magnetic measurements. Units based on the attraction and repulsions capable of being exerted between two unit magnetic poles at unit distance apart, or between a unit magnetic pole and a unit electric current.

**ELECTRO-METALLURGY.** That branch of electric science which relates to the electric reduction or treatment of metals. Electro-metallurgical processes effected by the agency of electricity. Electro-plating or electro-typing.

**ELECTRO-NEGATIVE.** In such a state as regards electricity as to be repelled by bodies negatively electrified, and attracted by

those **positively electrified**. The ions or radicals which appear at the anode or positive electrode of a decomposition cell.

**ELECTRO-NEGATIVE IONS.** The **negative ions**, or groups of atoms or radicals, which appear at the anode or **positive terminal** of a decomposition cell. The anions.

**ELECTRO-PLATING.** The process of covering any conducting surface with a metal, by the aid of an electric current.

**ELECTRO-POSITIVE.** In such a state, as regards an electric charge, as to be attracted by a body **negatively electrified**, and repelled by a body **positively electrified**. The ions or radicals which appear at the cathode or **negative electrode** of a decomposition cell.

**ELECTRO-POSITIVE IONS.** The cations or groups of atoms or radicals which appear at the **cathode** of a decomposition cell.

**ELECTROLYSIS.** Chemical **decomposition** effected by means of an electric current. The decomposition of the molecule of an electrolyte into its ions or radicals. Electrolytic decomposition.

**ELECTROLYTE.** Any **compound liquid** which is **separable** into its constituent ions or radicals by the passage of **electricity** through it.

**ELECTROLYTIC CELL.** A cell or vessel containing an electrolyte in which electrolysis is carried on. A plating cell or vat.

**ELECTROSTATIC CAPACITY.** (See Capacity Electrostatic.)

**ELECTROSTATIC DISCHARGE.** A term sometimes employed for a **disruptive discharge**.

**ELECTROSTATIC FIELD.** The region of **stress** existing about an electrified body due to its **electric potential**.

**ELECTROSTATIC FORCE.** The force of **attraction** or **repulsion** exerted between two electrified bodies due to their **potentials**.

**ELECTROSTATIC INDUCTION.** The induction of an electric charge produced in a conductor brought into an **electrostatic field**.

**ELECTROSTATIC LINES OF FORCE.** Lines of force produced in the neighborhood of a charged body, by the presence of the charge. Lines extending in the direction in which the force of **electrostatic attraction** or **repulsion** acts.

**ELECTROSTATIC POTENTIAL.** The power of doing electric work possessed by a **unit quantity** of electricity residing on the surface of an insulated body. That property in space by virtue of which work is done when an electric charge is moved therein.

**ELECTROSTATIC UNITS.** Units based on the **attractions** or **repulsions** of two **unit charges** of electricity at **unit distance** apart.

**ENERGY.** The power of doing work.

## DICTIONARY

## Sec. 1

**ENERGY COMPONENT OF E.M.F.** In an alternating current circuit the component of e.m.f. which is in phase with the current. In an alternating current circuit, the product of the current and the effective resistance.

**ENERGY COMPONENT OF CURRENT.** In an alternating current circuit the component of current which is in phase with the impressed e.m.f. In an alternating current, the product of the e.m.f. and the effective conductance.

**ENERGY, ELECTRIC.** The power which electricity possesses of doing work.

**EQUALIZER FEEDER.** A feeder whose principal purpose is to equalize the pressure between the ends of two or more other feeders, as distinguished from supplying current to feeding points.

**EQUIPOTENTIAL.** Of, or pertaining to an equality of potential.

**EQUIVALENT RESISTANCE.** A single resistance which may replace a number of resistances in a circuit without altering the current traversing it. Such a resistance in a simple-harmonic-current circuit as would permit energy to be absorbed, with the same effective current strength, at the same rate as an actual resistance in a complex-harmonic-current circuit.

**ERG.** The C.G.S. unit of work, or the work done when unit C. G. S. force is overcome through unit C. G. S. distance. The work accomplished when a body is moved through a distance of one centimeter with the force of one dyne. A dyne-centimeter.

## F.

**FAHRENHEIT THERMOMETRIC SCALE.** The thermometric scale in which the length of the thermometer tube, between the melting point of ice and the boiling point of water, is divided into 180 equal parts or degrees.

**FARAD.** The practical unit of electric capacity. Such a capacity of a conductor or condenser that one coulomb of electricity is required to produce therein a difference of potential of one volt.

**FATIGUE OF IRON OR STEEL, MAGNETIC.** The change of magnetic hysteresis loss with time. Ageing of magnetic material.

**FEED.** To supply with an electric current. To move or regulate one or both of the carbon electrodes in an arc-lamp.

**FEEDER.** An electric circuit, used to supply power to a station or service, as distinguished from circuits confined to a single station.

**FEEDER DISTRIBUTION.** A feeder-and-main system of distribution.

**FEEDING POINT.** A point of connection between a feeder and the mains. A feeding center.

**FIELD, ELECTROSTATIC.** (See Electrostatic Field.)

**FIELD, MAGNETIC.** The region of stress existing around the poles of a magnet or a magnetized body, with reference to its effect upon a unit magnetic charge. Also the field around a conductor due to a current flowing in it.

**FOOT-POUND.** A unit of work. The amount of work required to raise one pound vertically through a distance of one foot.

**FOOT-POUND-PER-SECOND.** A rate of doing work equal to the expenditure of one foot-pound of energy per second.

**FOUCAULT OR EDDY CURRENTS.** It was observed a number of years before Faraday's discovery of induced currents, that a vibrating magnetic needle quickly came to rest when near or over a copper plate. Arago had in 1824 also shown that a magnetic needle suspended over a rotating copper disk rotates with the disk. Both

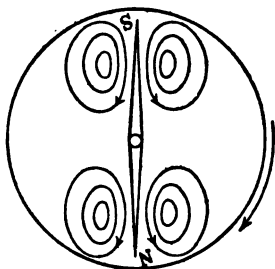

FIG. 1.—Foucault Currents Generated in Disk by Arago's Rotation.

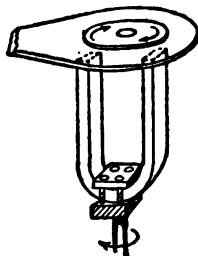

FIG. 2.—Another Form of Arago's Experiment.

the damping of the needle and Arago's disk experiment were explained by Faraday as phenomena of electro-magnetic induction. The relative motion of the magnet and the disk induces an e.m.f. in the metal disk. The current thus generated circulates in the disk, producing a magnetic action, which by Lenz's law tends to hold the magnet at rest relative to the disk or plate.

Electric currents, thus induced and circulating in a metallic mass, are called eddy currents or Foucault currents. The energy of such currents is dissipated in heat. The iron cores of armatures of dynamo machines and transformers are always laminated so as to offer resistance to the formation of such currents, and thus to stop the heat losses (Figs. 1 and 2).

**FREQUENCY.** The number of cycles or periods per second.

**FUNDAMENTAL FREQUENCY.** The nominal or lowest frequency of a complex harmonic electromotive force, flux or current.

**FUSE BLOCK.** A block containing a safety fuse, or fuses.

**FUSE BOX.** A box containing a safety fuse. A box containing fuse wires.

**FUSE, ELECTRIC.** A conductor designed to melt or fuse at a certain value of current and time and by so doing to rupture the circuit.

**FUSE LINKS.** Strips or plates of fusible metal in the form of links employed for safety fuses.

**FUSING CURRENT.** A term sometimes applied to the current which causes a fuse to melt.

G.

g. An abbreviation or symbol for the gravitation constant, or the force with which the earth acts upon unit mass at any locality. An abbreviation proposed for gramme, the unit of mass in physical investigations.

**GAINS.** The spaces cut in poles for the support and placing of the cross arms.

**GALVANIZING.** Covering iron with an adherent coating of zinc by dipping it in a bath of molten metal.

**GAUSS.** The name proposed in 1894 by the American Institute of Electrical Engineers for the C.G.S. unit of magnetic flux density. A unit of intensity of magnetic flux, equal to one C.G.S. unit of magnetic flux per-square-centimeter of area of normal cross-section. A name proposed for the C.G.S. unit of magnetic potential or magnetomotive force by the British Association in 1895.

**GILBERT.** A name proposed for the C.G.S. unit of magnetomotive force. A unit of magnetomotive force equal to that produced

by  $\frac{1}{1.2566}$  of one ampere-turn. That value of magnetic force which will establish one line or one maxwell per centimeter cube of air.

**GLOBE STRAIN-INSULATORS.** Insulators provided for the support of the strain wires in an overhead system.

**GRADIENT, ELECTRIC.** The rapidity of increase or decrease of the strength of an electromotive force. The vector space-rate of descent of electric potential at any point.

**GRAPHITE.** Graphite is used for rendering surfaces to be electro-plated, electrically conducting, and also for the brushes of dynamos and motors. For the latter purpose it possesses the additional advantage of decreasing the friction by means of its marked lubricating properties.



**GROUND.** A general term for the earth when employed as a return conductor. A term for the connection of a conductor to the earth.

**GROUND CIRCUIT.** A circuit in which the ground forms part of the path through which the current passes.

**GROUND, EFFECT OF.** On the neutral point of three-phase, three-wire systems. Consider a general case. A lightning stroke disables some apparatus so that inductive reactance is introduced in the accidental ground. Before the accident there was a perfectly balanced system, where the neutral, or ground potential, is symmetrical in reference to the line conductors and governed

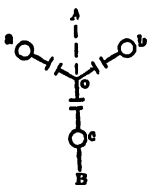

FIG. 3.

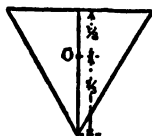

FIG. 4.

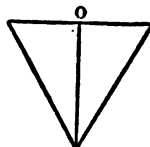

FIG. 5.

entirely by the ground capacities represented in Fig. 3, as three condensers. If, now, one line is grounded through an impedance, the neutral will be displaced along line AB.

The conditions are then:

First. Ground made by infinite reactance. (No Ground.) We have then

$$X = \infty, e_1 = \frac{2}{3e} \text{ and } e_2 = \frac{1}{3e} \text{ when } e_1 \text{ is the voltage from one wire}$$

to the neutral of a balance system and  $e_2$  is the voltage from the neutral of the balanced system to a point midway between the other two wires and  $X$  is the condensive reactance; that is, in Fig. 4 the neutral lies at  $O$ , and the ground is symmetrical in reference to the three lines.

Second, when  $e_2 = 0$ , and  $e_1 = e$  (shown in Fig. 5).

In this case the neutral lies midway between the other two conductors and its potential difference to ground is  $.87e$ .

Third, when  $e_1$  and  $e_2$  both become infinite, under such condition, the system would be subjected to infinite potential. The third condition arises if one line is grounded by a reactance of  $\frac{1}{3}$  of the condensive reactance, the system then being subjected to very great stresses, even at normal frequency.

**GROUND-RETURN.** A general term used to indicate the use of the ground or earth for part of an electric circuit. The earth or ground which forms part of the return path of an electric circuit.

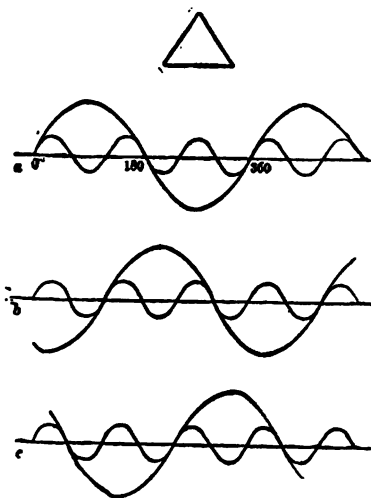

FIG. 6.—Relations of the Fundamental e.m.f. and Triple Harmonics in a Delta Connected Circuit.

**H.** A symbol for field intensity.

**H.** An abbreviation for the magnetizing force that exists at any point, or, generally for the intensity of magnetic force.

**H.B. CURVES.** Curves indicating the relations between magnetizing force and magnetic flux density in a magnetic substance. A term sometimes employed for magnetization curves.

**H.P.** An abbreviation for horse-power.

**HALL EFFECT.** A transverse electromotive

**GUTTA-PERCHA.** A resinous gum obtained from a tropical tree, and valuable electrically for its high insulating powers.

**GUY.** A rod, chain, rope, or wire employed for supporting or stiffening any structure such as a pole.

**GUY WIRE.** A wire employed as a guy.

**H.**

**H.** An abbreviation for the henry or practical unit of self induction.

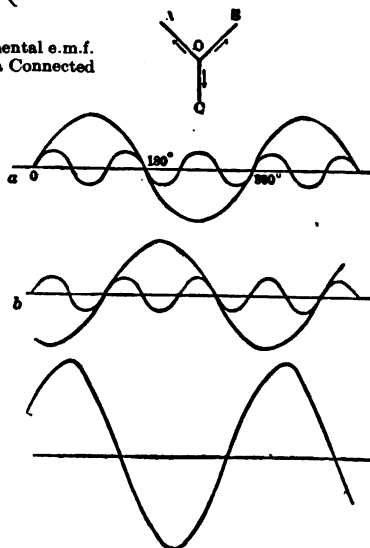

FIG 7.—Relation of the Fundamental e.m.f. and Triple Harmonics in a Star Connected Circuit.

force produced by a magnetic field in substances undergoing electric displacement.

**HARD-DRAWN COPPER WIRE.** Copper wire that is hardened by being drawn three or four times without annealing. Copper wire not annealed after leaving the die.

**HARMONIC CURRENTS.** Periodically alternating currents varying harmonically. Currents which are harmonic functions of time. Sinusoidal currents.

In modern alternators an endeavor is made to shape the magnetic circuit so that the e.m.f. is a sine wave, nevertheless, a triple harmonic of some magnitude usually exists in the e.m.f. wave of single-

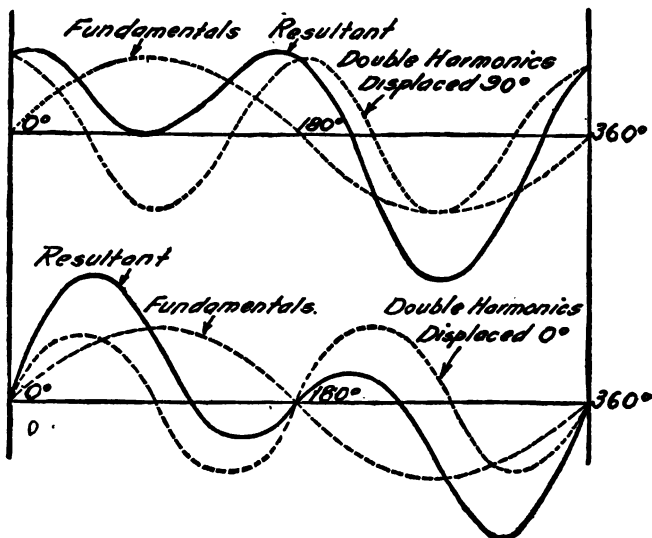

FIG. 8.

phase alternators, and in each of the individual phases of a polyphase generator.

The e.m.f. between two terminals of a three-phase generator, does, however, not contain any triple harmonic for the following reasons:

Consider first in Fig. 6 a delta-connected three-phase generator, in each phase of which is a prominent triple harmonic; a, b and c represent the three e.m.f.'s as displaced 120 degrees. It is seen that the three triple harmonics are in phase, thus the machine is really running under short circuit as far as the triple harmonic is concerned.

A triple frequency current will be established, which will consume the e.m.f. which, therefore, will not appear in the terminal e.m.f.

The triple harmonic current will, however, set up an armature reaction which will distort the field magnetism and thereby cause a

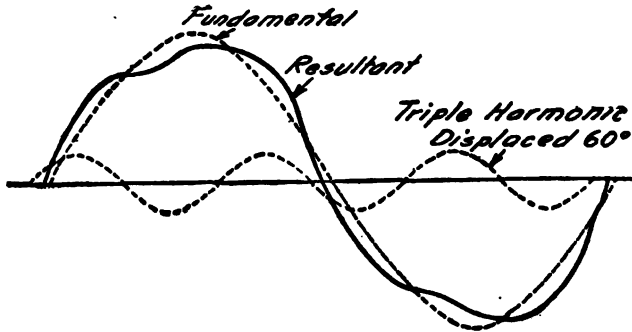

FIG. 9.

fifth and seventh harmonic. With star connection the terminal e.m.f. is the resultant of two e.m.f.'s, OA and OB in Fig. 7. Referring to Fig. 7 we see that again OA, OB and OC, the individual e.m.f.'s, are displaced 120 degrees. The e.m.f. between A and B is

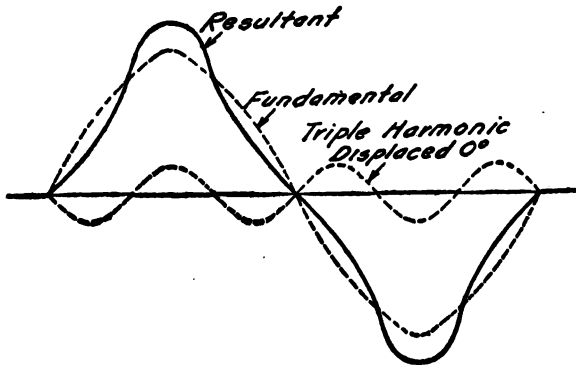

FIG. 10.

the resultant of OA and OB, thus  $OA - OB$  (the minus sign on account of the direction). In a are given the e.m.f.'s in OA, in b are given the e.m.f.'s of OB; and their resultant (with OB reversed) is

c. The triple harmonic again has disappeared, but the fundamental is larger than in the individual phase. In the e.m.f. against the neutral or ground the triple harmonic exists; therefore, the charging current against ground will be of triple frequency and any multiple thereof, if permitted to exist, that is, if the generator neutral is grounded.

The transformers are a source of triple harmonic e.m.f.'s or cur-

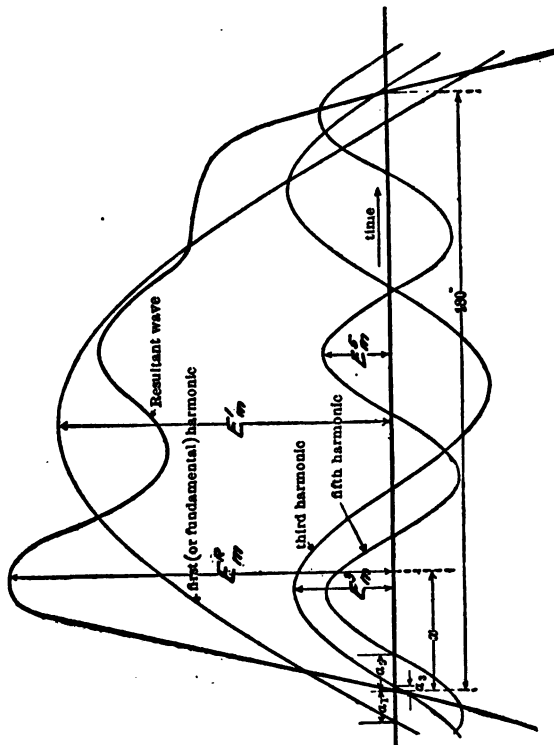

FIG. 11.

rents, but this can also be eliminated if one side of the transformers is delta connected, as should always be the case.

In general, it can be said that the triple harmonics should give no difficulties in a three-phase transmission; it need not exist.

**HARMONICS, EFFECTS OF HIGHER.** To elucidate the variation in the shape of alternating waves caused by various harmonics, in Fig. 8, Fig. 9, Fig. 10, and Fig. 11 are illustrated the wave forms produced by the super-imposition of the double, triple and the quintuple harmonic upon the fundamental sine wave.

In Fig. 12 is shown the fundamental sine wave and the complex

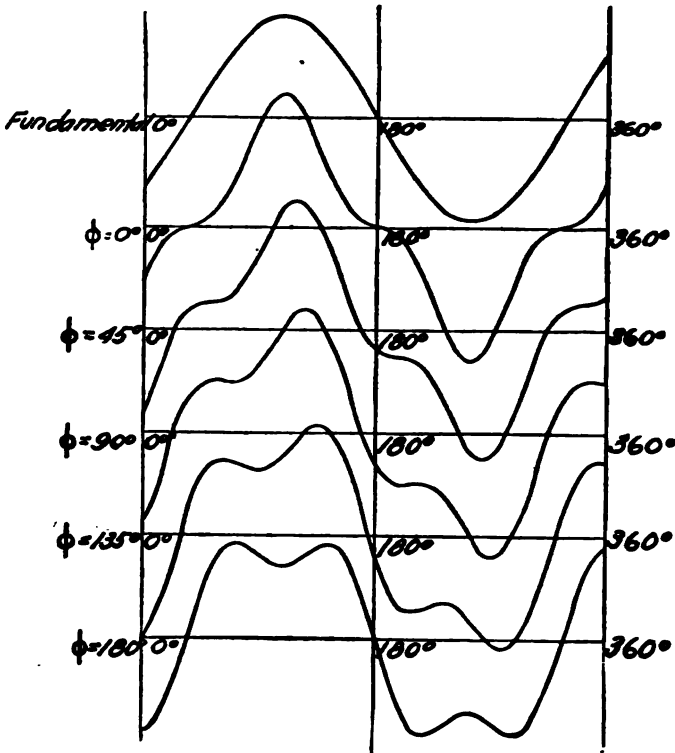

FIG. 12.—Various Distortions of the Fundamental Wave by Triple Harmonic in Different Phase Relation to the Fundamental.

waves produced by the superimposition of a triple harmonic of 30 percent of the amplitude of the fundamental, under the relative phase displacements of 0, 45, 90, 135 and 180 degrees.

As seen, the effect of the triple harmonic is in the first figure to flatten the zero values and point the maximum values of the wave, giving what is called a peaked wave. With increasing phase displacement of the triple harmonic, the flat zero rises and gradually

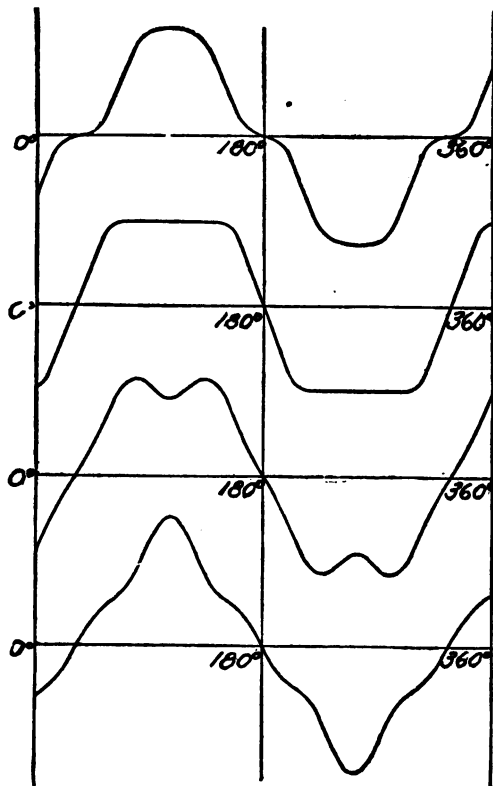

FIG. 13.—Various Distortions of the Fundamental Wave by Triple and Quintuple Harmonics of Characteristics given Below :

- |                           |                       |
|---------------------------|-----------------------|
| 1. 15% 3rd, $\phi = 0$    | 10% 5th, $\phi = 0$   |
| 2. 22½% 3rd, $\phi = 180$ | 5% 5th, $\phi = 180$  |
| 3. 15% 3rd, $\phi = 180$  | 10% 5th, $\phi = 0$   |
| 4. 15% 3rd, $\phi = 0$    | 10% 5th, $\phi = 180$ |

changes to a second peak, giving ultimately a **flat-top** or even **double-peaked** wave with sharp zero. The intermediate positions represent what is called a **saw-tooth** wave.

The **quintuple harmonic** causes a **flat-topped** or even **double-peaked** wave with flat zero. With increasing phase displacement, the wave becomes of the type called **saw-tooth** wave also. The flat zero rises and becomes a third peak, while of the two former peaks, one rises, the other decreases, and the wave gradually changes to a **triple-peaked** wave with one main peak, and a sharp zero.

As seen, with the **triple harmonic**, **flat-top** or **double-peak** coincides with **sharp zero**, while the **quintuple harmonic flat-top** or **double-peak** coincides with **flat zero**.

Sharp peak coincides with flat zero in the triple, with sharp zero in the quintuple harmonic. With the triple harmonic, the saw-tooth shape appearing in case of a phase difference between the fundamental and harmonic, is single, while with the quintuple harmonic it is double.

Thus in general, from simple inspection of the wave shape, the existence of these first harmonics can be discovered. Some characteristic shapes are shown in Fig. 13.

**HEAT.** A form of **energy**. A vibratory motion impressed on the molecules of matter by the action of any form of **energy**. A wave motion impressed on the universal ether by the action of some form of **energy**.

**HEAT UNIT.** The quantity of heat required to raise a **unit mass** of water through one degree of the thermometric scale—the **calorie**. There are a number of different heat units. The most important are:

The **British Heat Unit**, or **Thermal Unit**, or the amount of heat required to raise 1 pound of water 1 degree Fahr. This unit represents an amount of work equal to **772 foot-pounds**.

The **Calorie**, or the amount of heat required to raise the temperature of one gramme of water 1 degree C.

The **Joule**, or the quantity of heat developed in one second by the passage of a current of one ampere through a resistance of one ohm.

1 joule equals .2407 calories.

1 foot-pound equals 1.356 joules.

**HENRY.** The practical unit of **self-induction**. An earth-quad-rant or 10<sup>9</sup> centimeters. The value of the henry as adopted by the **International Electrical Congress** of 1893, at Chicago. The value of the induction in a circuit, when the electromotive force induced in the circuit in one **International volt**, and the inducing current varies at the rate of one **ampere per second**.

**HIGH FREQUENCY.** This term is used to some extent as defining **high commercial frequencies** such as 133 cycles per second. The term should rather be used to define frequencies much higher



than those in commercial use; i. e., frequencies produced by lighting discharges, arcing grounds, etc.

**HIGH POTENTIAL CURRENT.** A term loosely applied for a current produced by high electromotive forces.

**HIGH POTENTIAL INSULATOR.** An insulator suitable for use on high potential circuits.

**HIGH TENSION CIRCUIT.** A circuit employed in connection with high electric pressures.

**HORSE-POWER.** A commercial unit of power, or rate-of-doing-work. A rate-of-doing-work equal to 33,000 pounds raised one foot-per-minute, or 550 pounds raised one foot-per-second. A rate-of-doing-work equal to 4.562 kilograms raised one meter per minute.

**HORSE-POWER, ELECTRIC.** Such a rate-of-doing electrical work as is equal to 746 watts, or 746 volt-coulombs per second.

**HORSE-POWER-HOUR.** A unit of work equal to the work done by one horse-power acting for an hour. 1,980,000 foot-pounds.

**HYDRO-ELECTRIC SYSTEM.** An electric system with generators driven by water-power.

**HYSTERESIS.** A lagging behind of magnetization relatively to magnetizing force. Apparent molecular friction due to magnetic change of stress. A retardization of the magnetizing or demagnetizing effects as regards the causes which produce them. That quality of a para-magnetic substance by virtue of which energy is dissipated on the reversal of its magnetization.

**HYSTERESIS COEFFICIENT.** The hysteretic coefficient. The energy dissipated in a cubic centimeter of magnetic material by a single cyclic reversal of unit magnetic density.

**HYSTERETIC CYCLE.** A cycle of complete magnetization and reversal.

**HYSTERETIC LAG.** The lag in the magnetization of a transformer due to hysteresis.

## I.

I. An abbreviation for the amount of current.

I. H. P. An abbreviation for indicated horse-power.

**I<sup>2</sup>R LOSS.** The loss of power in any circuit equal to the square of the current in amperes by the resistance in ohms.

**IMPEDANCE COILS.** A term sometimes applied to choking coils, reactance coils, or economy coil.

**IMPEDANCE.** That quantity which when multiplied with the total current in amperes will give the impressed e.m.f. in volts.

**IMPRESSED ELECTROMOTIVE FORCE.** The electromotive force brought to act in any circuit to produce a current therein. In an alternating-current circuit, the electromotive force due to an impressed source, in contradistinction to the effective electromotive force, or that which is active in producing current, or the electromotive forces due to, or opposed to, self or mutual induction. An applied e.m.f. as distinguished from a resultant, or wattless e.m.f.

**INDIA RUBBER.** A resinous substance obtained from the milky juices of a tropical tree.

**INDUCED CURRENT.** When by any means whatever the total number of lines of force passing through any circuit is changed, an electric current is produced in that circuit. Such a current is called an induced current.

**INDUCED ELECTROMOTIVE FORCES.** e.m.f.'s set up by electro-dynamic induction.

**INDUCED M. M. F.** Any magnetomotive force produced by induction. The aligned or structural magnetomotive force as distinguished from the prime magnetomotive force.

**INDUCTANCE.** That property, in virtue of which a finite electromotive force impressed on a circuit does not immediately generate the full current due to the resistance of the circuit, and which, when the electromotive force is withdrawn, requires a finite time for the current strength to fall to its zero value. A property, by virtue of which the passage of an electric current is necessarily accompanied by the absorption of electric energy in producing a magnetic field. A constant quantity in a circuit at rest, and devoid of iron, depending only upon its geometrical arrangement, and usually expressed in henrys, or in centimeters.

**INDUCTANCE COIL.** An impedance, reactance, or choking coil. A coil placed in a circuit, for the purpose of preventing an impulsive current-rush in that circuit, by means of the counter-electromotive force developed in the coil on being magnetized.

**INDUCTION.** The property by which one body having electrical or magnetic polarity causes or induces it, in another body or another part of its own body without direct contact.

**INDUCTION, MAGNETIC.** The production of magnetism in a magnetizable substance by bringing it into a magnetic field.

**INDUCTION, MUTUAL.** Induction produced by two neighboring circuits on each other by the mutual interaction of their magnetic fields.

**INDUCTION, SELF.** (See Self Induction.)

**INDUCTIVE CIRCUITS.** Circuits containing certain types of apparatus and known as inductive circuits have the property of storing up a part of the energy supplied to the circuits during a

part of each cycle, and restoring this energy to the source during the remainder of the cycle. This causes the reversal of current to take place at an earlier or a later instant than the reversal of voltage, the current being known then as a lagging current. During the time when energy is being delivered to the circuit, the product of voltage and current is positive; that is, the voltage and the current have the same sign. When either voltage or current is reversed with respect to the other so that this product is negative, power is being returned, by the circuit to the source, and is then reckoned as a negative. The net value of the energy delivered to the circuit per cycle is equal to the difference between the positive and the negative values of energy in the two periods above referred to. The average value of the power for a given value of voltage and current is then less than the product of the voltage and the current (the volt-amperes) and may have any value between the value of the volt-amperes and zero.

**INDUCTIVE CIRCUIT.** Any circuit in which induction occurs.

**INDUCTIVE REACTANCE.** Reactance due to self induction as distinguished from reactance due to a condenser.

**IN-PUT.** The power absorbed by any machine in causing it to perform a certain amount of work.

**INSTANTANEOUS PEAK.** The highest value reached by the quantity under consideration as measured by some device which indicated high actual value of the quantity at every moment.

**INSULATE.** To so cover or protect a body as to prevent electricity from being conducted to or removed from it.

**INSULATED WIRES.** Wires provided with insulating coverings or coatings.

**INSULATING JOINT.** A joint in an insulating material or covering in which the continuity of the insulating material is insured.

**INSULATING VARNISH.** An electric varnish formed of any good insulating material.

**INSULATION RESISTANCE.** The resistance existing between a conductor and the earth or between two conductors in a circuit through insulating materials lying between them. A term applied to the resistance of the insulating material of a covered wire or conductor to an impressed voltage tending to produce a leakage of current.

**INSULATOR, ELECTRIC.** A body or substance which offers such resistance to the passage of electric current that it is used to prevent the passage of current. Any device employed for insulating a wire or other body.

**INSULATOR PIN.** The device by which an insulator is attached to a bracket, cross-arm, or support.

**IRON-CORE-LOSS.** The hysteretic and Foucault losses due to the presence of an iron core.

**J.**

**JOULE.** A volt coulomb or unit of electric energy or work. The amount of electric work required to raise the potential of one coulomb of electricity one volt. Ten million ergs.

The value of the joule as adopted by the International Electrical Congress of 1893, at Chicago. A value equal to  $10^7$  units of work of the C.G.S. system and represented with sufficient accuracy for practical purposes by the energy expended in one second by one ampere in one International ohm.

**JOULE'S LAW OF HEATING.** In any given conductor the heat developed by an electric current in any given time varies directly as the square of the current, and as the resistance, that is, the heat varies as  $I^2R$ . Also since the total heat varies as the time, the total heat is

$I^2R T$   
or, if expressed in calories

$$\frac{I^2R T}{4.2}$$

**JUMPER.** A temporary shunt or short circuit put around a source, lamp or receptive device on a series-connected circuit, to enable it to be readily removed or repaired.

**K.**

**kg.** An abbreviation for kilogramme, a practical unit of mass.

**kgm.** An abbreviation for kilogramme meter, a practical unit of the moment of a couple or of work.

**kv-a.** An abbreviation for kilovolt-ampere.

**KAOLIN.** A variety of white clay sometimes employed for insulating purposes.

**KILO.** A prefix for one thousand times.

**KILOVOLT.** One thousand volts.

**KILOVOLT-AMPERE.** A kilovolt-ampere is 1000 volt-amperes. A volt-ampere is the product of an ampere times a volt. Its energy equivalent may be one kilowatt or zero, depending upon the phase relation between the current and voltage.

**KILOWATT.** One thousand watts.

## Sec. 1

## DICTIONARY

**KILOWATT-HOUR.** The amount of work equal to that performed by one kilowatt maintained steadily for one hour. An amount of work equal to 3,600,000 joules.

**KNIFE-SWITCH.** A switch which is opened or closed by the motion of a knife contact between parallel contact plates. A knife-edge switch or knife switch.

### L.

**LAGGING CURRENT.** A periodic current lagging behind the impressed electromotive force which produces it.

**LAMINATED CORE.** An iron core that has been sub-divided in planes parallel to its magnetic flux-paths, in order to avoid the injurious production of Foucault or eddy currents.

**LAMINATION.** The sub-division of an iron core into laminae.

**LEAD.** A very malleable and ductile metal of low tenacity and high specific gravity. Tensile strength 1600 to 2400 pounds per square inch. Elasticity very low, and the metal flows under a very slight strain. Lead dissolves to some extent in pure water, but water containing carbonates or sulphates forms over it a film of insoluble salt which prevents further action. Atomic weight 206.9. Specific gravity 11.07 to 11.44. Melts at about 625° F.; softens and becomes pasty at 617° F.

**LEAD-ENCASED CABLE.** A cable provided with a sheathing or coating of lead on its external surface.

**LEADING CURRENT.** An alternating current wave or component, in advance of the electromotive force producing it.

**LEAKAGE REACTANCE.** That portion of the reactance of any induction apparatus which is due to stray flux.

**LEG OF CIRCUIT.** A branch of a bifurcated or divided circuit. A loop or offset in a series circuit.

**LENZ'S LAW.** In all cases of induction the direction of the induced current is such as to oppose the motion which produces it.

**LIGHTNING ARRESTER.** A device by means of which the apparatus placed in any electric circuit is protected from the destructive effects of a flash or discharge of lightning.

**LIGHTNING ROD.** A rod, strap, wire or stranded cable, of good conducting material, placed on the outside of a house or other structure, in order to protect it from the effects of a lightning discharge.

**LINES OF FORCE.** Lines of magnetization.

**LINES OF MAGNETIZATION.** A term sometimes applied for lines of magnetic induction. A term sometimes applied to those

portions of the lines of magnetic force which lie within the magnetized substance.

**LIVE WIRE.** A wire through which current is passing. A wire connected with an electric pressure or source.

**LOAD.** The work thrown on any machine.

**LOAD-FACTOR.** The fraction expressed in percent obtained by dividing the average load over any given period of time by the maximum load during the same period of time.

**LOGARITHM.** The exponent, or the power to which it is necessary to raise a fixed number called the base, in order to produce a given number.

**LOOP TEST.** A localization test for a fault in a loop of two wires, or in a complete metallic circuit.

**LOW-POTENTIAL SYSTEM.** In the National Electric Code a system having a pressure less than 550 and more than 10 volts.

**M.**

**m.** A symbol for strength of magnetic pole.

**m.** An abbreviation for meter, a practical unit of length.

**M, m.** An abbreviation for mass.

**mm.** An abbreviation for millimeter.

**m.m.f.** An abbreviation for magnetomotive force.

**MAGNETIC FATIGUE.** (See Fatigue of Iron and Steel, Magnetic.)

**MAGNETIC FIELD.** (See Field Magnetic.)

**MAGNETIC FLUX.** The streamings that issue from and return to the poles of a magnet. The total number of lines of magnetic force in any magnetic field. The magnetic flow that passes through any magnetic circuit.

**MAGNETIC FLUX-PATHS.** Paths taken by magnetic flux in any magnetic circuit.

**MAGNETIC FORCE.** The force which causes the attractions and repulsions of magnetic poles.

**MAGNETIC INTENSITY.** Magnetic flux-density. The quantity of magnetic flux per-unit-of-area of normal cross-section.

**MAGNETIC SATURATION.** The maximum magnetization which can be imparted to a magnetic substance. The condition of iron or other magnetic substance, when its intensity of magnetiza-

tion is so great that it fails to be further magnetized by any magnetizing force, however great.

**MAGNETIC UNITS.** Units based on the force exerted between magnet poles. Units employed in dealing with magnets and magnetic phenomena. The magnetic system of C.G.S. electromagnetic units, as distinguished from the electrostatic system.

**MAGNETIZING FORCE.** The force at any point with which a unit magnetic pole would be acted on.

**MAINS.** In a parallel system of distribution the conductors carrying the main current, and to which translating devices are connected.

**MASS.** Quantity of matter contained in a body.

**MAXIMUM DEMAND.** The maximum demand is the maximum load specified, contracted for or used, expressed in terms of power as kilowatts or horse-power.

**MAXWELL.** The unit of magnetic flux.

**MEAN CURRENT.** The time average of a current strength. In an alternating-current circuit, the time average of a current strength without regard to sign or direction.

**MEAN ELECTROMOTIVE FORCE.** The average electromotive force. In an alternating-current circuit the time average of the e.m.f. without regard to sign or direction.

**MECHANICAL EQUIVALENT OF HEAT.** The amount of mechanical energy converted into heat that would be required to raise the temperature of a unit mass of water one degree of the thermometric scale. The quantity of energy mechanically equivalent to one heat unit. (See Heat Unit.)

**MEGOHM.** One million ohms.

**MESSENGER ROPE.** In cable-work a rope drive for operating a drum or winch at a distance. A rope supporting guide sheaves.

**MHO.** The unit of conductance. Such a conductance as is equal to the reciprocal of one ohm. A unit of electric conductance of the value of  $10^9$  absolute units.

**MICA.** A refractory mineral substance employed as an insulator. A double silicate of alumina or magnesia and potash or soda.

**MICROFARAD.** One-millionth of a farad.

**MICROMETER WIRE-GAUGE.** A sensitive form of wire gauge, usually constructed with a fine thread screw, having a graduated head for close measurements of wire diameters.

**MICROHM.** The millionth of an ohm.

**MIL.** A unit of length used in measuring the diameter of wires equal to the one-thousandth of an inch.

**MIL-FOOT.** A resistance standard consisting of a foot of wire, or other conducting material, one mil in diameter. A standard of comparison of resistivity or conductivity of wires.

**MILLI-AMPERE.** The thousandth of an ampere.

**MILLI-HENRY.** A thousandth part of a henry.

**MILLI-VOLT.** The thousandth of a volt.

**MODULUS OF ELASTICITY.** The ratio of the simple stress required to produce a small elongation or compression in a rod of unit area of normal cross-section, to the proportionate change of length produced.

**MOISTURE-PROOF INSULATION.** A type of insulation which is not strictly water-proof, but which is capable of being immersed for a short time without suffering serious loss of insulation.

**MULTIPLE CIRCUIT.** (See Circuit Multiple.)

**MULTIPLE-SERIES CIRCUIT.** A circuit in which a number of separate sources, or receptive devices, or both, are connected in a number of separate groups in series, and these separate groups subsequently connected in multiple.

**MUTUAL INDUCTION.** (See Induction, Mutual.)

**N.**

**N.** Used to designate the number of turns of a conductor in electro-magnetic equations or calculations. Also used to indicate the number of revolutions per minute (R.P.M.).

**n.** An abbreviation for a number.

**NEGATIVE CONDUCTOR.** The conductor connected to the negative terminal of an electric source.

**NEGATIVE FEEDERS.** The feeders connecting the negative mains with the negative poles of the generators.

**NEUTRAL CONDUCTOR.** The middle wire in a three wire "Edison system." The wire from the common point of connection of the phases in four wire, three phase and five wire, two phase systems.

**NEUTRAL FEEDER.** In a three-wire system, a feeder connected with the neutral bus-bar.

**NON-CONDUCTOR.** Any substance whose conductivity is low, or whose electric resistance is great.



**NON-INDUCTIVE RESISTANCE.** A resistance devoid of self-induction.

**NORMAL CURRENT.** The current strength at which a system or apparatus is designed to be operated.

## O.

$\Omega$  An abbreviation for ohm, the practical unit of resistance.

$\omega$  A symbol sometimes employed for angular velocity.

**OERSTED.** The name used for the C.G.S. unit of magnetic reluctance. The reluctance offered to the passage of magnetic flux by a cubic centimetre of air when measured between parallel faces.

**OHM.** The practical unit of electric resistance. Such a resistance as would limit the flow of electricity under an electromotive force of one volt, to a current of one ampere, or one-coulomb-per-second. The value of the ohm as adopted by the International Electrical Congress of 1893, at Chicago, is a value of the ohm equal to  $10^9$  units of resistance of the C.G.S. system of electro-magnetic units, and represented by the resistance offered to an unvarying electric current by a column of mercury at the temperature of melting ice, 14.4521 grammes in mass, of a constant cross-sectional area, and of the length of 106.3 centimeters.

**OHMIC DROP.** The drop in pressure due to the ohmic resistance.

**OHMIC RESISTANCE.** The true resistance of a conductor due to its dimensions and conductivity, as distinguished from the spurious resistance produced by counter-electromotive force. A resistance such as would be measurable in ohms by the usual methods of continuous-current measurement.

**OHM'S LAW.** The law of non-varying current strength in a circuit not subject to variation. The strength of a continuous current is directly proportional to the difference of potential or electromotive force in the circuit and inversely proportional to the resistance of the circuit, i. e., is equal to the quotient arising from dividing the electromotive force by the resistance.

Ohm's law is expressed algebraically thus:

$$I = \frac{E}{R}; \text{ or } E = IR; \text{ or } R = \frac{E}{I}$$

If the electromotive force is given in volts, and the resistance in ohms, the formula will give the current strength directly in amperes.

The current in amperes is equal to the electromotive force in volts divided by the resistance in ohms.

The electromotive force in volts is equal to the product of the current in amperes and the resistance in ohms.

The resistance in ohms is equal to the electromotive force in volts divided by the current in amperes.

**OPEN CIRCUIT.** A broken circuit, or a circuit whose conducting continuity is broken.

**OSCILLATORY CURRENT.** A current which oscillates or performs periodic vibrations usually of diminishing amplitude.

**OVERHEAD CONDUCTOR.** An aerial conductor.

P.

**PAGE EFFECT.** Faint sounds produced when a piece of iron is rapidly magnetized and demagnetized.

**PAPER CABLE.** A paper-insulated cable. A cable in which paper is the solid insulator employed.

**PARAFFINE.** A solid hydro-carbon possessing high insulating powers.

**PARALLEL CIRCUIT.** A term sometimes used for multiple circuit.

**PEAK-LOAD.** The highest average load carried for any specified period.

**NOTE.** The term may be preceded by the qualifying terms "hourly," "daily," "monthly," "yearly," etc.

**PEAK.** The highest load carried for any specified period.

**PERCENTAGE CONDUCTIVITY OF WIRE.** The conductivity of a wire in terms of the conductivity of pure copper. The conductivity of a particular copper wire compared with the conductivity of a standard wire of the same dimensions. The conductivity of a wire referred to Matthiessen's standard of conductivity for copper.

**PERIODIC FUNCTION.** A periodic function is one which repeats itself after a definite time or period. If any number of simple sine functions of the same period be added, the resultant sum will be a simple sine function of the same period. This is shown in Fig. 14 for the addition of two simple sine functions or sine waves, and it is evident that, if true for the addition of two, it is true for the addition of any number of simple sine functions. An example of the addition of two simple sine functions of the same period is shown in Fig. 15. The resultant curve, represented by the heavy line, is likewise a sine curve.

**PERIODICITY.** The number of periods executed per second by a periodically alternating quantity. The number of cycles executed in unit time by an alternating current. The frequency of an alternating current.

**PERMITTANCE.** Electrostatic capacity. The capability of a condenser or dielectric to hold a charge.

**PETTICOAT INSULATOR.** An insulator provided with a deep internal groove, around its lower extremity or stalk. A line wire

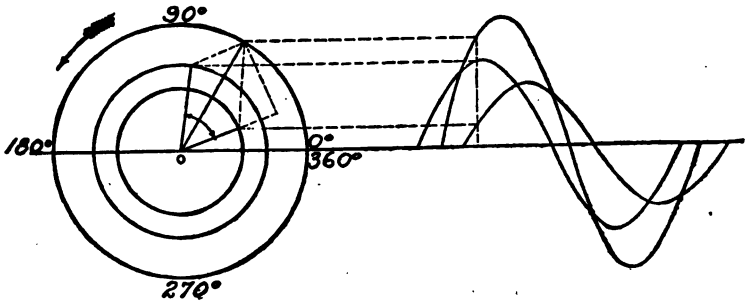

FIG. 14.—Summation of Two Simple Sine Waves to Form a Resultant Sine Wave.

vertical insulator provided with an insulating inverted cup having a form resembling a petticoat.

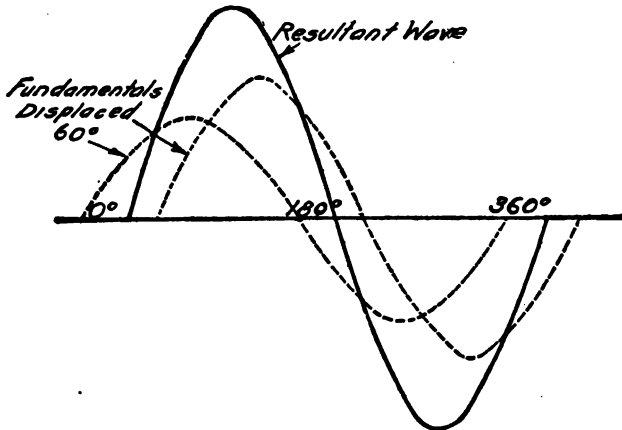

FIG. 15.—Diagram showing the Formation of a Resultant Sine Wave from Two Simple Sine Waves.

**PHASE.** The distance, usually in angular measure, of the base of any ordinate of an alternating wave from any chosen point on the time axis, is called the phase of this ordinate with respect to this

point. In the case of a **sinusoidal alternating** quantity the phase at any instant may be represented by the corresponding position of a line or **vector** revolving about a point with such an angular velocity ( $\omega = 2\pi f$ ) that its projection at each instant upon a convenient reference line is proportional to the value of the quantity at that instant.

**PHASE ANGLE.** In alternating current systems two or more currents or e.m.f.'s which do not come to their maximum values at the same instant are said to be out of phase, or to have a phase difference, and the **angle** between the **vectors** which represent these currents or e.m.f.'s is called a phase angle. If it is measured forward, in the direction of rotation, the angle is called the **angle of**

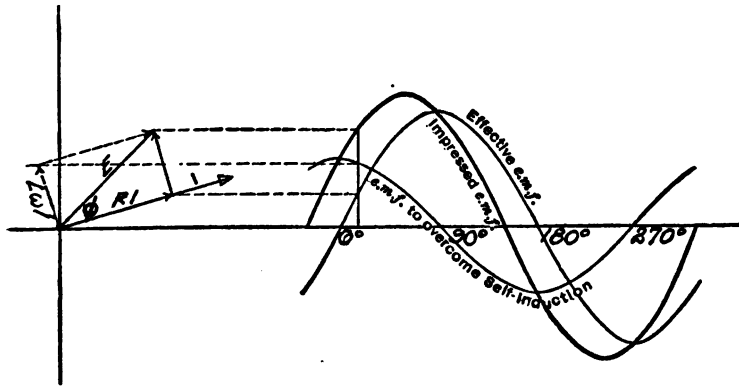

FIG. 16.—Diagram showing the Phase Angles between Three Distinct e.m.f.'s. and their Vector Representations.

**lead**, and if measured against the direction the angle is called the **angle of lag**. (Fig. 16.)

**PHASE DIFFERENCE: LEAD and LAG.** When corresponding cyclic values of two **sinusoidal alternating** quantities of the same frequency occur at different instants, the two quantities are said to differ in phase by the **angle** between their nearest corresponding values, e.g., their nearest ascending zeros or positive maxima. That quantity whose maximum value occurs first in time is said to lead the other, and the latter is said to lag behind the former.

**PINS.** Wooden or steel pegs for supporting pole line insulators.

**PLANE VECTOR.** A quantity which possesses not only magnitude but also direction in a single plane.

**PLATINUM.** A heavy refractory and not readily oxydizable metal of a tin-white color.

**PLUMBAGO.** An allotropic modification of carbon.

**POLE GUYS.** A guy employed for stiffening a pole.

**POLE STEPS.** Steps permanently fastened to a wood or iron pole to facilitate climbing.

**POLYPHASE.** Possessing more than a single phase.

**POLYPHASE CIRCUITS.** The circuits employed in polyphase-current distribution.

**POLYPHASE CURRENTS.** Currents differing in phase from one another by a definite amount, and suitable for the operation of polyphase motors or similar apparatus.

**POLYPHASE TRANSFORMER.** A transformer suitable for use in connection with polyphase circuits.

**POLYPHASE TRANSMISSION.** Transmission of power by means of polyphase currents.

**PORCELAIN.** A variety of insulating substance, made from clay.

**POSITIVE WIRE.** The wire connected with the positive pole of a source.

**POTENTIAL, ELECTRIC.** The power of doing electric work. Electric level.

**POTENTIAL ENERGY.** Stored energy. Capability of doing work. Energy, possessing the power or potency of doing work but not actually performing such work.

**POWER.** Rate-of-doing-work, expressible in watts, joules-per-second, foot pounds-per-hour, etc.

**POWER CIRCUITS.** Circuits employed for the electric transmission of power.

**POWER-FACTOR.** The ratio of the power (cyclic average) to the volt-amperes. In the case of sinusoidal current and voltage the power-factor is equal to the cosine of the difference in phase between them.

**PRIMARY.** That winding of a transformer which directly receives power. The term is to be preceded, in the case of transformers, by the words "high voltage" or "low voltage."

**PRIMARY COIL OF TRANSFORMER.** That coil of an induction coil or transformer on which the primary electromotive force is impressed. The coil which receives energy prior to transformation.

**PRIMARY CURRENTS.** Currents flowing in a primary circuit, as distinguished from currents flowing in a secondary circuit.

**PRIMARY ELECTROMOTIVE FORCE.** The electromotive force applied to the primary coil of a transformer.

**PULSATING CURRENT** is a current which pulsates regularly in magnitude. As ordinarily employed, the term refers to **unidirectional** current.

**Q.**

**QUADRATURE.** A term applied to express the fact that one simple-harmonic quantity lags  $90^\circ$  behind another.

**QUANTITY, ELECTRIC.** The amount of electricity present in any current or charge.

**QUARTER PHASE.** A term implying the supplying of power through two circuits. The vector angle of this voltage is 90 degrees. This term is used at times instead of the term "two-phase."

**QUARTER-PHASE SYSTEM.** A two-phase system of alternating-current distribution employing two currents dephased by a quarter period.

**R.**

**r.m.s.** A term sometimes used for the square root of the mean square of the current. The effective current or voltage.

**RADIAN.** A unit angle. An angle whose circular arc is equal in length to its radius; or, approximately  $57^\circ 17' 45''$ .

**RADIAN-PER SECOND.** A unit of angular velocity of a rotating body.

**RATIO OF TRANSFORMATION.** The ratio between the electromotive force produced at the secondary terminals of an induction coil or transformer, and the electromotive force impressed on the primary terminals.

**REACTANCE, INDUCTIVE.** The inductance of a coil or circuit multiplied by the angular velocity of the sinusoidal current passing through it, or expressed by the formula  $X = 2\pi f L = \omega L$ , where  $\omega = 2\pi f$ ,  $f$  is the frequency in cycles per second, and  $L$  is the coefficient of self-induction.

A quantity whose square added to the square of the resistance gives the square of the impedance, in a simple harmonic current circuit.

**REACTANCE FACTOR.** The ratio of the reactance of a coil, or circuit, to its ohmic resistance.

**REACTIVE DROP.** The drop in a circuit or conductor due to its reactance as distinguished from the drop due to its ohmic resistance.

**REACTIVE ELECTROMOTIVE FORCE.** In an alternating current circuit, that component of the electromotive force that is in quadrature with the current and is employed in balancing the counter e.m.f. of inductance.

**REACTIVE FACTOR.** The ratio of the wattless volt-amperes to the total volt-amperes.

**REGULATION.** The regulation of a machine or apparatus in regard to some characteristic quantity, such as current or terminal voltage, is the ratio of deviation of that quantity from its normal value at rated-load to the normal rated-load value. Sometimes called inherent regulation.

**RELUCTANCE.** A term applied to magnetic resistance. In a magnetic circuit the ratio of the m.m.f. to the total magnetic flux.

**RELUCTIVITY.** The specific magnetic resistance of a medium.

**RESIDUAL MAGNETISM.** The magnetism remaining in a core of an electromagnet on the opening of the magnetizing circuit. The small amount of magnetism retained by soft iron when removed from any magnetic field.

**RESIN.** A general term applied to a variety of dried juices of vegetable origin.

**RESISTANCE.** The quality of an electrical conductor by virtue of which it opposes an electric current. The unit of resistance is the ohm.

Resistance is that attribute of a conductor or of a circuit which determines the strength of the electric current that can be sent through the conductor or the circuit, on which a constant difference of potential is maintained, as shown by Ohm's law. The resistance of a given conductor is always constant at the same temperature, irrespective of the strength of current flowing through it or the electromotive force of the current, and the resistance of a given conductor increases as the length of the conductor increases; that is, the resistance of a conductor is directly proportional to its length. Also the resistance of a conductor varies inversely as its sectional area, or the resistance of a conductor of circular cross section is inversely proportional to the square of its diameter.

The combined resistance of several resistances in parallel may be found by taking the reciprocal of the sum of the reciprocals of the individual resistances of the branch circuits. This law follows from the law of conductance, which states that the combined conductance of a parallel branch circuit is equal to the sum of the conductances of the branches, and since the resistance is equal to the reciprocal of the conductance, the reciprocal law holds true, as above stated.

**RESISTIVITY.** The specific resistance of a substance referred to the resistance of a cube of unit volume. Specific resistance, or the inverse of specific conductivity.

**RESONANCE.** In a circuit containing both inductance and capacity, the neutralization or annulment of inductance-reactance by capacity-reactance, whereby the impedance of the circuit or branch is reduced to the ohmic resistance. In an alternating-current circuit, the attunement of a circuit, containing a condenser to the same natural undamped frequency of oscillation as the frequency of impressed e.m.f. whereby the circuit responds to this frequency more than to any other. In an alternating current circuit, the annulment of inductance-reactance by capacity-reactance, whereby the impedance of the circuit is not only reduced to its ohmic resistance, but its current is in phase with its impressed e.m.f.

**RESULTANT MAGNETIC FIELD.** A single magnetic field produced by two or more co-existing magnetic fields.

**RIGHT-HANDED ROTATION.** A direction of rotation which is the same as that of the hands of a watch, when one looks directly at the face of the watch. Negative rotation.

**ROOT-MEAN-SQUARE** or **EFFECTIVE VALUE.** The square root of the mean of the squares of the instantaneous values for one complete cycle. It is usually abbreviated r.m.s. Unless otherwise specified the numerical value of an alternating current (or e.m.f.) refers to its r.m.s. value. The r.m.s. value of a sinusoidal wave is equal to its maximum value divided by  $\sqrt{2}$ .

S.

**S.W.G.** An abbreviation for Stubb's wire gauge.

**SADDLE BRACKET.** A bracket holding an insulator and fastened to the top of a pole.

**SAFETY FUSE.** A wire, bar, plate or strip of readily fusible metal, capable of conducting, without fusing, the current ordinarily employed on the circuit, but which fuses and thus automatically breaks the circuit on the passage of an abnormally strong current.

**SAG OF CONDUCTOR OR LINE WIRE.** The dip of an aerial wire or conductor, between two adjacent supports, due to its weight.

**SECONDARY AMPERE-TURNS.** Ampere-turns in the secondary of a transformer or induction coil.

**SECONDARY.** That portion of a transformer which receives power by induction. The term is to be preceded by the same words as in the case of "primary."

**SECONDARY COIL OF TRANSFORMER.** The coil of a transformer into which energy is transferred from the primary line and primary coil by induction.

**SECONDARY CURRENTS.** The currents produced in the secondary of a transformer. The currents produced by secondary batteries. Currents in any secondary circuit.



## Sec. 1

## DICTIONARY

**SECONDARY RESISTANCE.** The resistance of a secondary coil or circuit.

**SECONDARY WINDING** is that winding of a transformer which receives power from the primary by induction.

**NOTE:** The terms "High-tension winding" and "Low-tension winding" are suitable for distinguishing between the windings of a transformer where the relations of the apparatus to the source of power are not involved.

**SELF-INDUCTION.** (See Induction, Self.)

**SERIES CIRCUIT.** (See Circuit, Series.)

**SERIES DISTRIBUTION.** A distribution of electric energy in which the receptive devices are placed one after another in succession upon a single conductor, extending throughout the entire circuit from pole to pole.

**SERIES-MULTIPLE CIRCUIT.** A compound circuit in which a number of separate sources, or separate electro-receptive devices, or both, are connected in a number of separate groups in multiple, and these separate groups subsequently connected in series.

**SERVICE WIRES.** The wires which lead into a building and which are connected to the supply mains or supply circuits. The wires through which service is given to a consumer. Delivery wires.

**SHELLAC.** A resinous substance obtained from the roots and branches of certain tropical plants, which possesses high insulating powers, and high specific inductive capacity.

**SHORT CIRCUIT.** A shunt or by-path of negligible or comparatively small resistance, placed around any part of an electric circuit through which so much of the current passes as to virtually cut out the parts of the circuit to which it acts as a shunt. An accidental direct connection between the mains or main terminals of a dynamo or system producing a heavy overload of current.

**SIMPLE HARMONIC ELECTROMOTIVE FORCE.** An electromotive force whose value varies directly as the sine or cosine of the angle which its rotating vector makes with a fixed axis.

**SINE.** One of the trigonometrical functions. The ratio of the vertical leg of a right-angle triangle to the hypotenuse, in which the hypotenuse is the radius vector, and the angle between the base and the hypotenuse the angle whose sine is considered.

**SINE LAW.** A law of magnitude defined by the sines of angles. A magnitude which follows the sines of successive angles.

**SINGLE-PHASE.** A term characterizing a circuit energized by a single alternating e.m.f. Such a circuit is usually supplied through two wires. The currents in these two wires counted positively outwards from the source, differ in phase by 180 degrees or half a cycle.

**SINGLE-POLE CUT-OUT.** A cut-out by means of which the circuit is broken or cut in one of the two leads only.

**SINUSOIDAL ALTERNATING ELECTROMOTIVE FORCES.** Alternating electromotive forces whose variations in strength are correctly represented by a sinusoidal curve.

**SINUSOIDAL CURVE.** A curve of sines. A curve which to rectangular co-ordinates has an ordinate at each point proportionate to the sine of an angle proportionate to the abscissa.

**SKIN EFFECT.** The tendency of rapidly alternating currents to avoid the central portions of solid conductors and flow, for the greater part, through the superficial portions.

**SLEEVE JOINT.** A junction of the ends of conducting wires obtained by passing them through tubes, and subsequently twisting and soldering.

**SOFT DRAWN COPPER WIRE.** Copper wire that is softened by annealing after being drawn.

**SPECIFIC CONDUCTIVITY.** The particular conductivity of a substance for electricity. Conductivity with reference to Matthiessen's standard conductivity.

**SPECIFIC INDUCTIVE CAPACITY.** The ability of a dielectric to permit induction to take place through its mass as compared with the ability possessed by a vacuous space of the same dimensions, under precisely the same conditions. The relative power of bodies for transmitting electrostatic stresses and strains, analogous to permeability in metals. The ratio of the capacity of a condenser whose coatings are separated by a dielectric of a given substance, to the capacity of a similar condenser, whose plates are separated by a vacuum.

**SPECIFIC RESISTANCE.** The particular resistance a substance offers to the passage of electricity through it, compared with the resistance of some standard substance. In absolute measurements, the resistance in absolute units between opposed faces of a centimetre cube of a given substance. In the practical system, the above resistance in ohms.

**SPELTER.** A name sometimes given to commercial zinc. (See Zinc.)

**SPLICING SLEEVE.** A tube of conducting material employed for covering a splice in a conducting wire.

**SPLIT PHASE.** A difference produced between the phases of two or more alternating currents into which a uniphase alternating current has divided.

**SQUARE MIL.** A unit of area employed in measuring the areas of cross-section of wires, equal to .000001 square inch. A unit of area equal to 1.2732 circular mils.

**STAR THREE-PHASE SYSTEM.** A system in which all three phase windings are connected together at a common point or neutral point, and the three free ends connected to the circuit.

**STATIC DISCHARGE.** A name sometimes given to a disruptive discharge.

**STATIC ELECTRICITY.** A term applied to electricity produced by friction.

**STEP-DOWN TRANSFORMER.** A transformer in which a small current of comparatively great difference of potential is converted into a large current of comparatively small difference of potential.

**STEP-UP TRANSFORMER.** A transformer in which a large current of comparatively small difference of potential is converted into a small current of comparatively great difference of potential.

**STRAIN.** Any change of size or shape, any deformation.

**STRAIN INSULATOR.** An insulator used for the double purpose of taking the mechanical strain at a bend or at the end of a conductor, and also insulating the same electrically.

**STRANDED CONDUCTOR.** A conductor formed of a number of smaller interlaced or twisted conductors, either for the purpose of reducing self-induction, or eddy currents, or for increasing its flexibility.

**STRAY CURRENTS.** A term sometimes used for eddy currents. Also currents that leave their normal or proper path such as earth currents of ground return feeders.

**STRAY FIELD.** Leakage magnetic flux. That portion of a magnetic field which does not pass through an armature or other magneto-receptive device.

**STRENGTH OF CURRENT.** (See Current Strength.)

**STRESS.** Any action between two bodies that causes a strain, or deformation.

**SUPPLY MAINS.** A term sometimes applied to the mains in a system of incandescent light or power distribution.

**SURFACE DENSITY.** The quantity of electricity-per-unit-of-area at any point on a charged surface.

**SURGING DISCHARGE.** A discharge accompanied by electric surgings. An oscillatory discharge.

**SURGINGS, ELECTRIC.** Electric oscillations set up in a conductor that is undergoing rapid discharging, or in neighboring conductors that are being rapidly charged and discharged. Electric oscillations, direct or induced.

**SYNCHRONISM.** Unison of frequencies in alternating-current systems or apparatus. Generally, the co-periodicity and co-phase

of two periodically recurring events. The coincidence in cyclic recurrence of two or more periodic variables, without regard to amplitude.

**SYNCHRONOSCOPE.** A synchronizing device which, in addition to indicating synchronism, shows whether the machine is synchronized fast or slow.

T.

**TANGENT.** The tangent of any angle may be found by constructing a right triangle in which the angle or its supplement is one of the acute angles of the triangle. By dividing the opposite side of the triangle by the adjacent side, the tangent of the angle is obtained. Also

$$\text{Tangent } \theta = \frac{\text{Sine } \theta}{\text{Cosine } \theta}$$

**TAP.** A conductor attached as a shunt to a larger conductor. A derived circuit for carrying off a share of the main current.

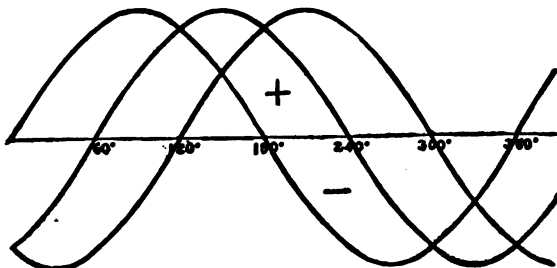

FIG. 17.—Relation of the Waves of Current, or e.m.f.'s, in a Three-phase System.

**TEMPERATURE.** State of matter in respect to heat.

**TEMPERATURE COEFFICIENT.** A coefficient of variation in a quantity, per degree of change in temperature. The coefficient by which a change of temperature must be multiplied in order to arrive at the change in a quantity due to the change of temperature.

**TERMINAL VOLTAGE.** The voltage between the poles at the source of the e. m. f.

**THREE-PHASE.** A term characterizing the combination of three circuits energized by alternating e.m.f.'s. which differ in phase by one-third of a cycle; i. e., 120 degrees. (Fig. 17.)

**THREE-PHASE TRANSFORMER.** A transformer constructed for changing the ratios of voltages and currents of a three-phase system.

**THREE-PHASE TRANSMISSION.** Transmission by means of three-phase currents.

**THREE-WIRE CIRCUIT.** A circuit employed in a three-wire system. A three-wire two phase system. A three-wire three phase system.

**THREE-WIRE MAINS.** The mains employed in a three-wire system of distribution.

**THREE-WIRE SYSTEM.** A system of electric distribution for lamps or other multiple-connected translating devices, in which three conductors are employed in connection with two dynamos, or parts of transformers connected in series, the central or neutral conductor being connected to the junction of this apparatus, and the two other conductors to the remaining free terminal of each.

**TIE-WIRE.** Binding wire of an insulator. Wire which binds an overhead wire to the groove of its insulator.

**TIME-CONSTANT OF CIRCUIT.** The time in which a current will fall in a circuit when the e.m.f. is suddenly removed, in a ratio whose Napierian logarithm is unity. The ratio of the inductance of a circuit to its resistance.

**TIME SWITCH.** A switch arranged to open or close a circuit at a certain time or after the lapse of a certain time.

**TRANSFORMER.** A stationary piece of apparatus for transforming, by electro-magnetic induction, power from one circuit to another, or for changing, through such transformation, the values of the electromotive force or current.

**TRANSFORMER-BALANCER.** An auto-transformer for dividing a voltage in constant proportions, and usually into two equal portions.

**TRANSFORMER STAMPINGS.** Sheet steel stampings of such shape as is suitable for building up the laminated core of a transformer.

**TRANSMISSION CIRCUIT, ELECTRIC.** The circuit employed to receive the apparatus necessary in any transfer of electric energy from the generators to the receptive devices. In alternating-current constant-potential transmission circuits the following average voltages are in general use: 6,600, 11,000, 22,000, 33,000, 44,000, 66,000, 88,000, 110,000.

**TRANSMISSION, ELECTRIC.** The transference of energy from one point to another by means of electric currents.

**TRANSPOSING.** A device for avoiding the bad effects of mutual induction by alternately crossing equal lengths of consecutive sections of the line.

**TRIPLE PETTICOAT INSULATOR.** An aerial line insulator having three discs or petticoats.

**TWO-PHASE.** A term characterizing the combination of two circuits energizing by alternating e.m.f.'s. which differ in phase by a quarter of a cycle; i. e., 90 degrees. (Fig. 18.)

**TWO-WIRE MAINS.** A name for the mains employed in the ordinary system of multiple distribution, as distinguished from a three-wire main, or that used in a three-wire system.

V.

**VECTOR DIAGRAM.** A diagram representing the relations of vector quantities.

**VECTOR QUANTITY.** A quantity possessing both direction and magnitude.

**VECTOR SUM.** The geometrical sum of two or more vector quantities. Thus, in Fig. 16 by completing the parallelogram formed

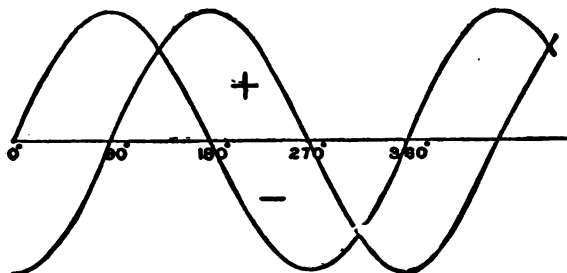

FIG. 18.—Relation of the Waves of Current, or e.m.f.'s. in a Two-phase System.

by the vectors  $\omega LI$  and  $RI$ , and drawing the diagonal, the vector  $E$  is obtained, which is the vector sum of  $\omega LI$  and  $RI$ . In practice, these vectors are drawn free-hand and the resultants calculated by means of the geometrical laws. (Fig. 19.)

**Example.** It is intended to find the value of e.m.f. between two wires, across each of which to the neutral is maintained an e.m.f.  $\frac{E}{2}$ . It is known that these two e.m.f.'s. differ 90 degrees. In Fig. 19,

which is a right angle triangle,  $OB = \sqrt{OA^2 + AB^2}$  or

$$E' = \sqrt{\left(\frac{E}{2}\right)^2 + \left(\frac{E}{2}\right)^2} = \sqrt{2 \left(\frac{E}{2}\right)^2}$$

$$E' = E \sqrt{\frac{1}{2}} = \frac{E}{\sqrt{2}} = \frac{E}{1.41}$$

**VOLT.** The practical unit of electromotive force. Such an electromotive force as is induced in a conductor which cuts lines of magnetic flux at the rate of 100,000,000 per second. Such an electromotive force as would cause a current of one ampere to flow against a resistance of one ohm. Such an electromotive force as

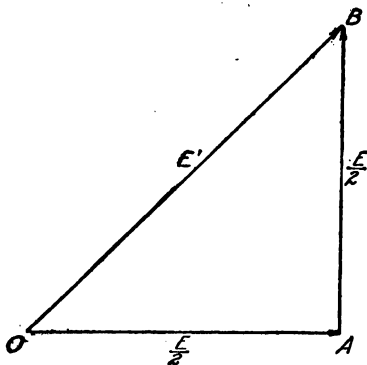

FIG. 19.—Vector Diagram for Calculating the Vector Sum of Two e.m.f.'s. in Ninety-degree Phase Relation.

would charge a condenser of the capacity of one farad with a quantity of electricity equal to one coulomb.  $10^8$  absolute electro-magnetic units of electromotive force.

The value of the volt as adopted by the International Electrical Congress of 1893, at Chicago, is an electromotive force which is represented with sufficient accuracy for practical use by  $\frac{1000}{1434}$  of the electromotive force between the poles or electrodes of the voltaic cell known as Clark's cell, at a temperature of  $15^{\circ}$  Cent. when prepared in accordance with certain specifications.

**VOLT AMPERE.** The product of one volt times one ampere.

W.

**w-hr.** An abbreviation for watt-hour, a practical unit of electric energy.

**WATT.** A unit of electric power. A volt ampere at unity power-factor. The power developed when 44.25 foot-pounds of work are done in a minute, or 0.7375 foot-pound of work is done in a second.

The value of the watt as adopted by the International Electrical Congress of 1893, at Chicago, is a value equal to 10<sup>7</sup> units of activity in the C.G.S. system, and equal to the work done at the rate of one joule-per-second.

**WATT-HOUR.** A unit of electric work. A term employed to indicate the expenditure of an electric power of one watt for an hour.

**WATTLess COMPONENT OF CURRENT.** In an alternating-current circuit, that component of the current which is in quadrature with the impressed e.m.f. and which, therefore, takes from or gives no energy to the circuit. In an alternating-current circuit the product of the e.m.f. and the effective susceptance.

**WATTLess COMPONENT OF ELECTROMOTIVE FORCE.** In an alternating-current circuit, that component of the e.m.f. which is in quadrature with the current strength, and, therefore does not work on the current. In an alternating-current circuit the product of the current and the effective reactance.

**WAVE, ELECTRIC.** An electric periodic disturbance.

**WEATHER-PROOF INSULATION.** A trade-name for a character of insulation consisting of one or more layers of braided material soaked in an insulating compound.

**WEATHER-PROOF WIRE.** A wire provided with weather-proof insulation.

**WIRE.** A slender rod or filament of drawn metal.

**WORK.** When a force acts on a body the product of the force by the distance through which it acts in the direction of the force is called the work performed by the force. Thus, when a force applied to a heavy body raises it a certain vertical distance, work is performed by the force, the amount of the work being the product of the force and the distance of ascent; and when a horizontal force draws a body horizontally the work is the product of the force and the horizontal distance. The unit of work is the work done by the unit force in acting through unit distance. When the dyne is taken as unit of force and the cm. as unit of length, the unit of work is that performed by a dyne acting through a cm. and is called an erg. Since this is a very small unit, a multiple of it, namely 10,000,000 ergs, is frequently used and is called a joule.

In practical mechanical work the unit of time is always one minute, and the unit which measures the work performed in a given



time is the **foot-pound per minute**. This unit is called the unit of mechanical power.

Power is, therefore, rate of doing work, and hence the power exerted can always be determined by dividing the work done in foot-pounds by the time in minutes required to do it. In practical electrical work the unit of time is the second, and the unit which measures the work performed in a given time is the **joule per second**. This unit is called the unit of electrical power, and has been named the **watt**.

The equation or formula expressing the power exerted in any electrical circuit is determined as follows: The electrical power is expressed by **watts = joules per second**, but **joules = volt-coulombs**, and hence **joules per second = volt-coulombs per second**. Therefore also, **watts = volt-coulombs per second**. Now, **coulombs per second = amperes**. Inserting this value above, **watts = volts  $\times$  amperes**, or  **$W = EI$** .

When the power is to be expressed by the current and resistance, the formula is obtained as follows: According to formula  **$W = EI$** . According to Ohm's law,  **$E = IR$** . Substituting this value of  **$E = IR$**  in the formula  **$W = EI$** , we have

$$W = I \times I \times R = I^2 R.$$

When the power is to be expressed by the electromotive force and resistance, the formula is obtained as follows: According to formula

**$W = EI$** . According to Ohm's law,  **$I = \frac{E}{R}$** . Substituting this value of  **$I = \frac{E}{R}$**  in  **$W = EI$** , we have  **$W = \frac{E}{R} E = \frac{E^2}{R}$**

For alternating current

$$W = \frac{E^2}{R + \frac{X^2}{R}}$$

## Y.

**Y-CONNECTOR.** A connector resembling the letter Y in shape for joining a conductor to two branch wires.

**Y-CURRENT.** The current between any wire of a three-phase system and the neutral point.

## Z.

**ZINC, Zn.** Atomic weight 65. Specific gravity 7.14. Melts at 780° F. Volatilizes and burns in the air when melted, with bluish-white fumes of zinc oxide. It is ductile and malleable but to a much less extent than copper, and its tenacity, about 5000 to 6000

lbs. per square inch, is about one-tenth that of wrought iron. It is practically non-corrosive in the atmosphere, a thin film of carbonate of zinc forming upon it. Cubical expansion between 32° and 212° F., 0.0088. Specific heat .096. Electric conductivity 29, heat conductivity 36, silver being 100. Its principal uses are for coating iron surfaces, called "galvanizing," and for making brass and other alloys.

**ZINC PLATING.** Electro-plating with zinc. Galvanizing.

**THE GREEK ALPHABET.**

Name	Large	Small	Commonly used to designate
alpha ..	A	a	angles, coefficients.
beta ...	B	β	angles, coefficients.
gamma	Γ	γ	specific gravity.
delta ..	Δ	δ	density, variation.
epsilon.	E	ε	base of hyperbolic logarithms.
zeta ...	Z	ζ	co-ordinates, coefficients.
eta ....	H	η	hysteresis (Steinmetz) coefficient, efficiency
theta ..	Θ	θ	angular phase displacement.
iota ...	I	ι	
kappa .	K	κ	dielectric constant.
lambda	Λ	λ	conductivity.
mu ....	M	μ	permeability.
nu ....	N	ν	reluctivity.
xi .....	Ξ	ξ	output coefficient.
omicron	O	ο	
pi .....	Π	π	circumference ÷ diameter.
rho ....	P	ρ	resistivity.
sigma ..	Σ	σ	(cap.), summation; leakage coefficient.
tau ....	T	τ	time-phase displacement.
upsilon	Υ	υ	
phi ....	Φ	φ	flux.
chi ....	Χ	χ	
psi ....	Ψ	ψ	angular velocity in time.
omega .	Ω	ω	(small), angular velocity in space.



...

...

...

...

...

**TABLE No. 1**

**COMMON LOGARITHMS OF NUMBERS**

COMMON LOGARITHMS OF NUMBERS.											
100-129											
N	O	1	2	3	4	5	6	7	8	9	D
100	00 000	043	087	130	173	217	260	303	346	389	43
101	432	475	518	561	604	647	689	732	775	817	43
102	860	903	945	988	*030	*072	*115	*157	*199	*242	42
103	01 284	328	368	410	452	494	536	578	620	662	42
104	703	745	787	828	870	912	953	995	*036	*078	42
105	02 119	160	202	243	284	325	366	407	449	490	41
106	531	572	612	653	694	735	776	816	857	898	41
107	938	979	*019	*060	*100	*141	*181	*222	*262	*302	40
108	03 342	383	423	463	503	543	583	623	663	703	40
109	743	782	822	862	902	941	981	*021	*060	*100	40
110	04 139	179	218	258	297	336	376	415	454	493	39
111	532	571	610	650	689	727	766	805	844	883	39
112	922	961	999	*038	*077	*115	*154	*192	*231	*269	39
113	05 306	346	385	423	461	500	538	576	614	652	38
114	690	729	767	805	843	881	918	956	994	*032	38
115	06 070	108	145	183	221	258	296	333	371	408	38
116	446	483	521	558	595	633	670	707	744	781	37
117	819	856	893	930	967	*004	*041	*078	*115	*151	37
118	07 183	225	262	298	335	372	408	445	482	518	37
119	555	591	628	664	700	737	773	809	846	882	36
120	918	954	990	*027	*063	*099	*135	*171	*207	*243	36
121	06 279	314	350	386	422	458	493	529	565	600	36
122	636	672	707	743	778	814	849	884	920	955	35
123	991	*026	*061	*096	*132	*167	*202	*237	*272	*307	35
124	08 342	377	412	447	482	517	552	587	621	656	35
125	691	726	760	795	830	864	899	934	968	*003	35
126	10 637	672	706	740	775	809	843	878	912	946	34
127	380	415	449	483	517	551	585	619	653	687	34
128	721	755	789	823	857	890	924	958	992	*025	34
129	11 059	093	126	160	193	227	261	294	327	361	34
PP	44	43	42	41	40	39	38	37	36		
1	4.4	4.3	4.2	4.1	4.0	3.9	3.8	3.7	3.6		
2	3.3	3.6	3.4	3.2	3.0	2.8	2.6	2.4	2.2		
3	13.2	12.9	12.6	12.3	12.0	11.7	11.4	11.1	10.8		
4	17.5	17.2	16.8	16.4	16.0	15.6	15.2	14.8	14.4		
5	22.0	21.5	21.0	20.5	20.0	19.5	19.0	18.5	18.0		
6	26.4	25.3	25.2	24.6	24.0	23.4	22.8	22.2	21.6		
7	30.3	30.1	29.4	28.7	28.0	27.3	26.6	25.9	25.2		
8	35.2	34.4	33.6	32.8	32.0	31.2	30.4	29.6	28.8		
9	39.6	38.7	37.8	36.9	36.0	35.1	34.2	33.3	32.4		

## COMMON LOGARITHMS OF NUMBERS.

130-159

N	O	1	2	3	4	5	6	7	8	9	D	
130	11 394	428	461	494	528	561	594	628	661	694	33	
131		727	760	793	826	859	892	925	958	*024	33	
132	12 067	099	132	165	198	232	264	297	330	363	33	
133		385	418	450	483	515	548	581	613	645	33	
134		719	751	783	815	847	879	911	943	*051	33	
135	13 033	065	098	130	162	194	226	258	290	322	33	
136		354	386	418	450	481	513	545	577	608	33	
137		672	704	735	767	798	829	860	891	922	33	
138		988	*019	*051	*082	*114	*145	*176	*208	*239	31	
139	14 301	333	364	395	426	457	488	519	550	581	31	
140		613	644	675	706	737	768	798	829	860	31	
141		922	953	983	*014	*045	*076	*106	*137	*168	31	
142	15 229	259	290	320	351	381	412	442	473	503	31	
143		534	564	594	625	655	685	715	745	775	30	
144		836	866	897	927	957	*017	*047	*077	*107	30	
145	16 137	167	197	227	256	286	315	345	374	403	30	
146		435	465	495	524	554	584	613	642	672	30	
147		732	761	791	820	850	879	908	937	967	29	
148	17 066	095	124	153	182	211	240	269	298	327	29	
149		319	348	377	406	435	464	493	522	551	29	
150		690	719	748	776	805	834	862	891	920	29	
151		898	926	955	984	*012	*041	*070	*099	*127	29	
152	18 194	212	241	270	298	327	355	384	412	441	29	
153		469	497	526	554	582	611	639	667	695	28	
154		752	780	808	837	865	893	921	949	977	*005	28
155	19 033	061	089	117	145	173	201	229	257	285	28	
156		312	340	368	395	424	451	479	507	535	28	
157		580	618	645	673	700	728	755	783	811	28	
158		866	893	921	948	976	*004	*032	*060	*088	27	
159	20 140	167	194	222	249	276	303	330	357	385	27	

PP	35	34	33	32	31	30	29	28	27
1	3.5	3.4	3.3	3.2	3.1	3.0	2.9	2.8	2.7
2	7.0	6.8	6.6	6.4	6.2	6.0	5.8	5.6	5.4
3	19.5	19.2	9.9	9.6	9.3	9.0	8.7	8.4	8.1
4	14.0	13.6	13.2	12.8	12.4	12.0	11.6	11.2	10.8
5	17.5	17.0	16.5	16.0	15.5	15.0	14.5	14.0	13.5
6	21.0	20.4	19.8	19.2	18.6	18.0	17.4	16.8	16.2
7	24.5	23.8	23.1	22.4	21.7	21.0	20.3	19.6	18.9
8	28.0	27.2	26.4	25.6	24.8	24.0	23.2	22.4	21.6
9	31.5	30.6	29.7	28.8	27.9	27.0	26.1	25.2	24.3

COMMON LOGARITHMS OF NUMBERS.											
160-189											
N	O	1	2	3	4	5	6	7	8	9	D
160	20 412	439	466	493	520	548	575	602	629	656	27
161	683	710	737	763	790	817	844	871	898	925	27
162	952	978	*005	*032	*059	*085	*112	*139	*165	*192	27
163	21 219	245	272	299	325	352	378	405	431	458	27
164	484	511	537	564	590	617	643	669	696	722	26
165	748	775	801	827	854	880	906	932	958	985	26
166	22 011	037	063	089	115	141	167	194	220	246	26
167	272	298	324	350	376	401	427	453	479	505	26
168	531	557	583	608	634	660	686	712	737	763	26
169	789	814	840	866	891	917	943	968	994	*019	26
170	23 045	070	096	121	147	172	198	223	249	274	25
171	300	325	350	376	401	426	452	477	502	528	25
172	553	578	603	629	654	679	704	729	754	779	25
173	805	830	855	880	905	930	955	980	*005	*030	25
174	24 055	080	105	130	155	180	204	229	254	279	25
175	304	329	353	378	403	428	452	477	502	527	25
176	551	576	601	625	650	674	699	724	748	773	25
177	797	822	846	871	895	920	944	969	993	*018	25
178	25 042	066	091	115	139	164	188	212	237	261	24
179	285	310	334	358	382	406	431	455	479	503	24
180	527	551	575	600	624	648	672	696	720	744	24
181	768	792	816	840	864	888	912	935	959	983	24
182	26 007	031	055	079	102	126	150	174	198	221	24
183	245	269	293	316	340	364	387	411	435	458	24
184	482	506	529	553	576	600	623	647	670	694	24
185	717	741	764	788	811	834	858	881	905	928	23
186	951	975	998	*021	*045	*068	*091	*114	*138	*161	23
187	27 184	207	231	254	277	300	323	346	370	393	23
188	416	439	462	485	508	531	554	577	600	623	23
189	646	669	692	715	738	761	784	807	830	852	23

PP	27	26	25	24	23	22
1	2.7	2.6	2.5	2.4	2.3	2.2
2	5.4	5.2	5.0	4.8	4.6	4.4
3	8.1	7.8	7.5	7.2	6.9	6.6
4	10.8	10.4	10.0	9.6	9.2	8.8
5	13.5	13.0	12.5	12.0	11.5	11.0
6	16.2	15.6	15.0	14.4	13.8	13.2
7	18.9	18.2	17.5	16.8	16.1	15.4
8	21.6	20.8	20.0	19.2	18.4	17.6
9	24.3	23.4	22.5	21.6	20.7	19.8

## COMMON LOGARITHMS

Sec. 1

## COMMON LOGARITHMS OF NUMBERS.

190-229

N	O	1	2	3	4	5	6	7	8	9	D
190	875	898	921	944	967	989	*012	*035	*058	*081	23
191	28 103	126	149	171	194	217	240	262	285	307	23
192	320	353	375	398	421	443	466	488	511	533	23
193	554	578	601	623	646	668	691	713	735	758	23
194	780	803	825	847	870	892	914	937	959	981	23
195	29 003	028	048	070	092	115	137	159	181	203	23
196	226	248	270	292	314	336	358	380	402	425	22
197	447	469	491	512	535	557	579	601	623	645	22
198	667	689	710	732	754	776	798	820	842	863	22
199	885	907	929	951	973	994	*016	*036	*056	*081	22
200	30 103	125	146	168	190	211	233	255	276	298	22
201	320	341	363	384	406	428	449	471	492	514	22
202	535	557	578	600	621	643	664	685	707	728	21
203	756	777	797	818	838	858	878	899	920	942	21
204	983	984	*005	*027	*048	*069	*091	*112	*133	*154	21
205	31 175	197	218	239	260	281	302	323	345	366	21
206	387	408	429	450	471	492	513	534	555	576	21
207	597	618	639	660	681	702	723	744	765	785	21
208	806	827	842	863	880	911	931	952	973	994	21
209	32 015	035	056	077	098	118	139	160	181	201	21
210	222	243	263	284	305	325	346	366	387	408	21
211	428	449	469	490	510	531	552	572	593	613	20
212	634	654	675	695	715	736	756	777	797	818	20
213	838	858	879	899	919	940	960	980	*001	*021	20
214	33 041	062	082	102	122	143	163	183	203	224	20
215	244	264	284	304	325	345	365	385	405	425	20
216	445	465	486	506	526	546	566	586	606	626	20
217	646	666	686	706	726	746	766	786	806	826	20
218	846	866	886	905	925	945	965	985	*005	*025	20
219	34 944	064	084	104	124	143	163	183	203	223	20
220	242	262	282	301	321	341	361	380	400	420	20
221	489	489	479	498	518	537	557	577	596	616	19
222	635	655	674	694	713	733	753	772	792	811	19
223	830	850	869	889	908	928	947	967	986	*005	19
224	35 025	044	064	083	102	122	141	160	180	199	19
225	218	238	257	276	295	315	334	353	372	392	19
226	411	430	449	468	488	507	526	545	564	583	19
227	603	622	641	660	679	698	717	736	755	774	19
228	793	812	832	851	870	889	908	927	946	965	19
229	984	*003	*021	*048	*068	*078	*097	*116	*135	*154	19
N	O	1	2	3	4	5	6	7	8	9	D



COMMON LOGARITHMS OF NUMBERS.											
230-269											
N	O	1	2	3	4	5	6	7	8	9	D
230	36 173	192	211	229	248	267	286	305	324	342	19
231	361	380	399	418	436	455	474	493	511	530	19
232	549	568	586	605	624	642	661	680	698	717	19
233	736	754	773	791	810	829	847	866	884	903	19
234	922	940	959	977	996	*014	*033	*051	*070	*088	18
235	37 107	125	144	162	181	199	218	236	254	273	18
236	291	310	328	346	365	383	401	420	439	457	18
237	475	493	511	530	548	566	585	603	621	639	18
238	658	676	694	712	731	749	767	785	803	822	18
239	840	858	876	894	912	931	949	967	985	*003	18
240	38 021	039	057	075	093	112	130	148	166	184	18
241	262	280	298	316	334	352	370	388	406	424	18
242	502	520	538	556	574	592	610	628	646	664	18
243	561	578	596	614	632	650	668	686	703	721	18
244	739	757	775	792	810	828	846	863	881	899	18
245	917	934	952	970	987	*005	*023	*041	*058	*076	18
246	39 094	111	129	146	164	182	199	217	235	252	18
247	270	287	305	322	340	358	375	393	410	428	18
248	445	463	480	498	515	533	550	568	585	602	18
249	620	637	655	672	690	707	724	742	759	777	17
250	794	811	829	846	863	881	898	915	933	950	17
251	967	985	*002	*019	*037	*054	*071	*088	*106	*123	17
252	40 140	157	175	192	209	226	243	261	278	295	17
253	312	329	346	364	381	398	415	432	449	466	17
254	483	500	518	535	552	569	586	603	620	637	17
255	654	671	688	705	722	739	756	773	790	807	17
256	824	841	858	875	892	909	926	943	960	976	17
257	993	*010	*027	*044	*061	*078	*095	*111	*128	*145	17
258	41 162	179	196	212	229	246	263	280	296	313	17
259	330	347	363	380	397	414	430	447	464	481	17
260	497	514	531	547	564	581	597	614	631	647	17
261	604	621	637	654	671	687	704	720	737	754	17
262	830	847	863	880	896	912	929	946	963	979	16
263	999	*012	*029	*045	*062	*078	*095	*111	*127	*144	16
264	42 160	177	193	210	226	243	259	275	292	308	16
265	325	341	357	374	390	406	423	439	455	472	16
266	498	504	521	537	553	570	586	602	619	635	16
267	651	667	684	700	716	732	749	765	781	797	16
268	813	830	846	862	878	894	911	927	945	959	16
269	975	991	*003	*024	*040	*056	*072	*088	*104	*120	16
N	O	1	2	3	4	5	6	7	8	9	D

## COMMON LOGARITHMS

Sec. 1

COMMON LOGARITHMS OF NUMBERS.											
270-309											
N	O	1	2	3	4	5	6	7	8	9	D
270	43 136	152	169	185	201	217	233	249	265	281	16
271	297	313	329	345	361	377	393	409	425	441	16
272	457	473	489	505	521	537	553	569	584	600	16
273	616	632	648	664	680	696	712	727	743	759	16
274	775	791	807	823	839	854	870	886	902	917	16
275	933	949	965	981	996	*012	*028	*044	*059	*075	16
276	44 091	107	122	138	154	170	185	201	217	232	16
277	248	264	279	295	311	326	342	358	373	389	16
278	404	420	436	451	467	483	498	514	529	545	16
279	560	576	592	607	623	638	654	669	685	700	16
280	716	731	747	762	778	793	809	824	840	855	15
281	871	886	902	917	932	948	963	979	994	*010	15
282	45 025	040	056	071	086	102	117	133	148	163	15
283	179	194	209	225	240	255	271	286	301	317	15
284	332	347	362	378	393	408	423	439	454	469	15
285	484	500	515	530	545	561	576	591	606	621	15
286	637	652	667	682	697	712	728	743	758	773	15
287	788	803	818	834	849	864	879	894	909	924	15
288	939	954	969	984	*000	*015	*030	*045	*060	*075	15
289	46 090	105	120	135	150	165	180	195	210	225	15
290	240	255	270	285	300	315	330	345	359	374	15
291	389	404	419	434	449	464	479	494	509	523	15
292	538	553	568	583	598	613	627	642	657	672	15
293	687	702	716	731	745	761	776	790	805	820	15
294	835	850	864	879	894	909	923	938	953	967	15
295	982	997	*012	*026	*041	*056	*070	*085	*100	*114	15
296	47 129	144	159	173	188	202	217	232	246	261	15
297	276	290	305	319	334	349	363	378	392	407	15
298	422	436	451	465	480	494	509	524	538	553	15
299	567	582	596	611	625	640	654	669	683	698	15
300	712	727	741	756	770	784	799	813	828	842	14
301	857	871	885	900	914	929	943	958	972	986	14
302	48 001	015	029	044	058	073	087	101	116	130	14
303	144	159	173	187	202	216	230	244	259	273	14
304	287	302	316	330	344	359	373	387	401	416	14
305	430	444	458	473	487	501	515	530	544	558	14
306	572	586	601	615	629	643	657	671	686	700	14
307	714	728	742	756	770	785	799	813	827	841	14
308	855	869	883	897	911	926	940	954	968	982	14
309	996	*010	*024	*038	*052	*066	*080	*094	*108	*122	14
N	O	1	2	3	4	5	6	7	8	9	D

COMMON LOGARITHMS OF NUMBERS.											
310-349											
N	O	1	2	3	4	5	6	7	8	9	D
310	49 138	169	164	178	192	206	220	234	248	262	14
311	276	290	304	318	332	346	360	374	388	402	14
312	415	429	443	457	471	485	499	513	527	541	14
313	554	568	582	596	610	624	638	651	665	679	14
314	683	707	721	734	748	762	776	789	803	817	14
315	831	845	859	872	886	900	914	927	941	955	14
316	869	982	996	*010	*024	*037	*051	*065	*079	*092	14
317	50 106	120	135	147	161	174	188	202	215	229	14
318	243	256	270	284	297	311	325	338	352	365	14
319	379	393	406	420	433	447	461	474	488	501	14
320	515	529	542	556	569	583	596	610	623	637	14
321	651	664	678	691	705	718	732	745	759	772	14
322	786	799	812	826	840	853	866	880	893	907	13
323	929	934	947	961	974	987	*001	*014	*028	*041	13
324	51 055	068	081	095	108	121	135	148	162	175	13
325	188	202	215	228	242	255	268	282	295	308	13
326	322	335	348	362	375	388	402	415	428	441	13
327	465	466	481	495	508	521	534	548	561	574	13
328	587	601	614	627	640	654	667	680	693	706	13
329	729	733	746	759	772	786	799	812	825	838	13
330	851	865	878	891	904	917	930	943	957	970	13
331	988	996	*009	*022	*035	*048	*061	*075	*088	*101	13
332	52 114	127	140	153	166	179	192	205	218	231	13
333	244	257	270	284	297	310	323	336	349	362	13
334	375	388	401	414	427	440	453	466	479	492	13
335	504	517	530	543	556	569	582	595	609	621	13
336	684	647	660	673	686	699	711	724	737	750	13
337	763	776	789	802	815	827	840	853	866	879	13
338	892	905	917	930	943	956	969	982	994	*007	13
339	53 020	033	046	058	071	084	097	110	122	135	13
340	148	161	173	186	199	212	224	237	250	263	13
341	275	286	301	314	328	339	352	364	377	390	13
342	403	415	428	441	453	466	479	491	504	517	13
343	529	542	555	567	580	593	605	618	631	643	13
344	658	668	681	694	706	719	732	744	757	769	13
345	782	794	807	820	832	845	857	870	882	895	13
346	908	920	933	945	958	970	983	995	*003	*020	13
347	54 033	045	058	070	083	095	103	120	133	145	13
348	158	170	183	195	208	220	233	245	258	270	12
349	283	295	307	320	332	345	357	370	382	394	12
N	O	1	2	3	4	5	6	7	8	9	D

## COMMON LOGARITHMS

Sec. 1

COMMON LOGARITHMS OF NUMBERS.											
350-389											
N	O	1	2	3	4	5	6	7	8	9	D
350	407	419	432	444	456	469	481	494	506	518	12
351	531	543	555	568	580	593	605	617	630	642	12
352	654	667	679	691	704	716	728	741	753	765	12
353	777	790	802	814	827	839	851	864	876	888	12
354	960	913	925	937	949	962	974	986	998	*011	12
355	55 023	035	047	060	072	084	096	108	121	133	12
356	145	157	169	182	194	206	218	230	242	255	12
357	267	279	291	303	315	328	340	352	364	376	12
358	388	400	413	425	437	449	461	473	485	497	12
359	509	522	534	546	558	570	582	594	606	618	12
360	630	642	654	666	678	691	703	715	727	739	12
361	751	763	775	787	789	811	823	835	847	859	12
362	871	883	895	907	919	931	943	955	967	979	12
363	991	*003	*015	*027	*038	*050	*062	*074	*086	*098	12
364	56 110	122	134	146	158	170	182	194	206	217	12
365	229	241	253	265	277	289	301	313	324	336	12
366	348	360	372	384	396	407	419	431	443	455	12
367	467	478	490	502	514	526	538	549	561	573	12
368	585	597	606	620	632	644	656	667	679	691	12
369	703	714	726	738	750	761	773	785	797	808	12
370	828	832	844	855	867	879	891	902	914	926	12
371	937	949	961	972	984	996	*003	*019	*031	*043	12
372	57 054	066	078	089	101	113	124	135	146	159	12
373	171	183	194	206	217	229	241	252	264	276	12
374	287	299	310	322	334	345	357	368	380	392	12
375	403	415	426	438	449	461	473	484	496	507	12
376	519	530	542	553	565	576	588	600	611	623	12
377	634	645	657	669	680	692	703	715	726	738	11
378	749	761	772	784	795	807	818	830	841	852	11
379	864	875	887	898	910	921	933	944	955	967	11
380	978	990	*001	*013	*024	*035	*047	*058	*070	*081	11
381	58 092	104	115	127	138	149	161	172	184	195	11
382	206	218	229	240	252	263	274	286	297	309	11
383	320	331	343	354	365	377	388	399	410	422	11
384	434	444	456	467	478	490	501	512	524	535	11
385	546	557	569	580	591	602	614	625	636	647	11
386	659	670	681	692	704	715	726	737	749	760	11
387	771	782	794	805	816	827	838	850	861	872	11
388	883	894	906	917	928	939	950	961	973	984	11
389	995	*036	*017	*028	*040	*051	*062	*073	*084	*095	11
N	O	1	2	3	4	5	6	7	8	9	D

COMMON LOGARITHMS OF NUMBERS.											
390-429											
N	O	1	2	3	4	5	6	7	8	9	D
390	59 106	118	129	140	151	162	173	184	195	207	11
391	218	229	240	251	262	273	284	295	306	318	11
392	329	340	351	362	373	384	395	406	417	428	11
393	439	450	461	472	483	494	506	517	528	539	11
394	550	561	572	583	594	605	616	627	638	649	11
395	660	671	682	693	704	715	726	737	748	759	11
396	770	780	791	802	813	824	835	846	857	868	11
397	879	890	901	912	923	934	945	956	967	977	11
398	988	999	*010	*021	*032	*043	*054	*065	*076	*086	11
399	60 097	108	119	130	141	152	163	173	184	195	11
400	206	217	228	239	249	260	271	282	293	304	11
401	314	325	336	347	358	369	379	390	401	412	11
402	423	433	444	455	466	477	487	498	509	520	11
403	531	541	552	563	574	584	595	606	617	627	11
404	638	649	660	670	681	692	703	713	724	735	11
405	746	756	767	778	788	799	810	821	831	842	11
406	853	863	874	885	895	906	917	927	938	949	11
407	959	970	981	991	*002	*013	*023	*034	*045	*055	11
408	61 066	077	087	098	109	119	130	140	151	162	11
409	172	183	194	204	215	225	236	247	257	268	11
410	278	289	300	310	321	331	342	352	363	374	11
411	384	395	405	416	426	437	448	458	469	479	11
412	490	500	511	521	532	542	553	563	574	584	11
413	595	606	616	627	637	648	658	669	679	690	11
414	700	711	721	731	742	752	763	773	784	794	10
415	805	815	826	836	847	857	868	878	888	899	10
416	909	920	930	941	951	962	972	982	993	*003	10
417	62 014	024	034	045	055	066	076	086	097	107	10
418	118	128	138	149	159	170	180	190	201	211	10
419	221	232	242	252	263	273	284	294	304	315	10
420	325	335	346	356	366	377	387	397	408	418	10
421	428	439	449	459	469	480	490	500	511	521	10
422	531	542	552	562	572	583	593	603	613	624	10
423	634	644	655	665	675	685	696	706	716	726	10
424	737	747	757	767	778	788	798	808	818	829	10
425	839	849	859	870	880	890	900	910	921	931	10
426	941	951	961	972	982	992	*002	*012	*022	*033	10
427	63 043	053	063	073	083	094	104	114	124	134	10
428	144	155	165	175	185	195	205	215	225	236	10
429	246	256	266	276	286	296	306	317	327	337	10
N	O	1	2	3	4	5	6	7	8	9	D

COMMON LOGARITHMS

Sec. 1

COMMON LOGARITHMS OF NUMBERS.

430-469

N	O	1	2	3	4	5	6	7	8	9	D
430	347	357	367	377	387	397	407	417	423	436	10
431	445	456	468	478	488	498	508	518	528	538	10
432	548	558	568	579	589	599	609	619	629	639	10
433	649	659	669	679	689	699	709	719	729	739	10
434	749	759	769	779	789	799	809	819	829	839	10
435	849	859	869	879	889	899	909	919	929	939	10
436	949	959	969	979	988	998	*008	*018	*028	*038	10
437	64 048	058	068	078	088	098	108	118	128	137	10
438	147	157	167	177	187	197	207	217	227	237	10
439	246	256	266	276	286	296	306	316	326	335	10
440	345	355	365	375	385	395	404	414	424	434	10
441	444	454	464	473	483	493	503	513	523	532	10
442	542	552	562	572	582	591	601	611	621	631	10
443	649	659	669	679	689	699	709	719	729	739	10
444	738	748	758	768	777	787	797	807	816	826	10
445	836	846	856	865	875	885	895	904	914	924	10
446	933	943	953	963	972	982	992	*002	*011	*021	10
447	65 031	040	050	060	070	080	089	099	108	118	10
448	128	137	147	157	167	176	186	196	205	215	10
449	225	234	244	254	263	273	283	292	302	312	10
450	321	331	341	350	360	369	379	389	398	408	10
451	418	427	437	447	456	466	475	485	495	504	10
452	514	523	533	543	552	562	571	581	591	600	10
453	610	619	629	639	648	658	667	677	686	696	10
454	706	715	725	734	744	753	763	772	782	792	9
455	801	811	820	830	839	849	858	866	877	887	9
456	896	906	916	925	935	944	954	963	973	982	9
457	992	*001	*011	*020	*030	*039	*049	*058	*068	*077	9
458	66 087	096	106	115	124	134	143	153	162	172	9
459	181	191	200	210	219	229	238	247	257	266	9
460	276	285	295	304	314	323	332	342	351	361	9
461	370	380	389	398	408	417	427	436	445	455	9
462	464	474	483	492	502	511	521	530	539	549	9
463	558	567	577	586	596	605	614	624	633	642	9
464	652	661	671	680	689	699	708	717	727	736	9
465	745	755	764	773	783	792	801	811	820	829	9
466	839	848	857	867	876	885	894	904	913	922	9
467	932	941	950	960	969	978	987	997	*006	*015	9
468	67 025	034	043	052	062	071	080	089	099	108	9
469	117	127	136	145	154	164	173	182	191	201	9
N	O	1	2	3	4	5	6	7	8	9	D

COMMON LOGARITHMS OF NUMBERS.											
470-509											
N	O	1	2	3	4	5	6	7	8	9	D
470	210	219	228	237	247	256	265	274	284	293	9
471	302	311	321	330	339	348	357	367	376	385	9
472	394	403	413	422	431	440	449	459	468	477	9
473	486	495	504	514	523	532	541	550	560	569	9
474	578	587	596	605	614	624	633	642	651	660	9
475	669	679	680	697	706	715	724	733	742	752	9
476	761	770	779	788	797	806	815	825	834	843	9
477	852	861	870	879	888	897	906	916	925	934	9
478	943	952	961	970	979	988	997	*006	*015	*024	9
479	68 034	043	052	061	070	079	088	097	106	115	9
480	124	133	142	151	160	169	178	187	196	205	9
481	215	224	233	242	251	260	269	278	287	296	9
482	305	314	323	332	341	350	359	368	377	386	9
483	395	404	413	422	431	440	449	458	467	476	9
484	485	494	502	511	520	529	538	547	556	565	9
485	574	583	592	601	610	619	628	637	646	655	9
486	664	673	681	690	699	708	717	726	735	744	9
487	753	762	771	780	789	797	806	815	824	833	9
488	842	851	860	869	878	886	895	904	913	922	9
489	931	940	949	958	966	975	984	993	*002	*011	9
490	69 020	028	037	046	055	064	073	082	090	099	9
491	108	117	126	135	144	152	161	170	179	188	9
492	197	205	214	223	232	241	249	258	267	276	9
493	285	294	302	311	320	329	338	346	355	364	9
494	373	381	390	399	408	417	425	434	443	452	9
495	461	469	478	487	496	504	513	522	531	539	9
496	548	557	566	574	583	592	601	609	618	627	9
497	636	644	653	662	671	679	688	697	705	714	9
498	723	732	740	749	758	767	775	784	793	801	9
499	810	819	827	836	845	854	862	871	880	888	9
500	897	906	914	923	932	940	949	956	966	975	9
501	984	992	*001	*010	*019	*027	*036	*044	*053	*062	9
502	70 070	079	088	096	105	114	122	131	140	148	9
503	157	165	174	183	191	200	209	217	226	234	9
504	243	252	260	269	278	286	295	303	312	321	9
505	329	338	346	355	364	372	381	389	398	406	9
506	415	424	432	441	449	458	467	475	484	492	9
507	501	509	518	526	535	544	552	561	570	578	9
508	586	595	603	612	621	629	638	646	655	663	9
509	672	680	689	697	706	714	723	731	740	749	9
N	O	1	2	3	4	5	6	7	8	9	D

## COMMON LOGARITHMS OF NUMBERS.

510-549

N	O	1	2	3	4	5	6	7	8	9	D
510	757	706	774	783	791	600	898	817	325	834	9
511	842	851	859	868	876	885	898	902	910	919	9
512	927	935	944	952	961	969	978	986	995	*003	9
513	71 912	920	929	937	946	954	963	971	979	988	8
514	696	105	113	121	129	138	147	155	164	172	8
515	181	189	198	206	214	222	231	240	248	257	8
516	265	273	282	290	299	307	315	324	332	341	8
517	349	357	366	374	383	391	399	408	416	425	8
518	433	441	450	458	466	475	483	492	500	508	8
519	517	525	533	542	550	559	567	575	584	592	8
520	609	617	625	634	642	648	656	659	667	675	8
521	684	692	700	709	717	725	734	742	750	759	8
522	767	775	784	792	800	808	817	825	834	842	8
523	859	858	867	875	883	892	900	908	917	925	8
524	933	941	950	958	966	975	983	991	999	*008	8
525	72 916	924	932	941	949	957	966	974	982	990	8
526	609	197	115	123	132	140	148	156	165	173	8
527	181	189	198	206	214	222	230	239	247	255	8
528	268	277	285	293	298	304	312	321	329	337	8
529	346	354	362	370	378	387	395	403	411	419	8
530	428	436	444	452	460	469	477	485	493	501	8
531	509	518	526	534	542	550	558	567	575	583	8
532	591	599	607	616	624	632	640	648	656	665	8
533	673	681	689	697	705	713	722	730	738	746	8
534	754	762	770	779	787	795	803	811	819	827	8
535	835	843	852	860	868	876	884	892	900	908	8
536	916	925	933	941	949	957	965	973	981	988	8
537	997	*006	*014	*022	*030	*038	*046	*054	*062	*070	8
538	73 978	986	994	102	111	119	127	135	143	151	8
539	160	167	175	183	191	199	207	215	223	231	8
540	299	247	255	263	272	280	288	296	304	312	8
541	320	328	336	344	352	360	368	376	384	392	8
542	400	408	416	424	432	440	448	456	464	472	8
543	480	428	436	444	452	460	468	476	484	492	8
544	500	508	516	524	532	540	548	556	564	572	8
545	580	548	556	564	572	580	588	596	604	612	8
546	719	727	735	743	751	759	767	775	783	791	8
547	799	807	815	823	830	838	846	854	862	870	8
548	878	886	894	902	910	918	926	933	941	949	8
549	957	965	973	981	988	997	*005	*013	*021	*028	8
N	O	1	2	3	4	5	6	7	8	9	D



COMMON LOGARITHMS OF NUMBERS.											
550-589											
N	O	1	2	3	4	5	6	7	8	9	D
550	74 036	044	052	060	068	076	084	092	099	107	8
551	115	123	131	139	147	155	162	170	178	186	8
552	194	202	210	218	225	233	241	249	257	265	8
553	273	280	288	296	304	312	320	327	335	343	8
554	351	359	367	374	382	390	398	406	414	421	8
555	429	437	445	453	461	468	476	484	492	500	8
556	507	515	523	531	539	547	554	562	570	578	8
557	586	593	601	609	617	624	632	640	646	654	8
558	663	671	679	687	695	702	710	718	726	733	8
559	741	749	757	764	772	780	788	796	803	811	8
560	819	827	834	843	850	859	865	873	881	889	8
561	896	904	912	920	927	935	943	950	958	066	8
562	974	981	989	997	*005	*012	*020	*028	*035	*043	8
563	75 051	059	066	074	082	089	097	105	113	120	8
564	128	136	143	151	159	166	174	182	189	197	8
565	205	213	220	228	236	243	251	259	266	274	8
566	282	289	297	305	312	320	328	335	343	351	8
567	358	366	374	381	389	397	404	412	420	427	8
568	435	442	450	458	465	473	481	488	496	504	8
569	511	519	526	534	542	549	557	565	572	580	8
570	587	595	603	610	618	626	633	641	648	656	8
571	664	671	679	686	694	702	709	717	724	732	8
572	740	747	755	762	770	778	785	793	800	808	8
573	815	823	831	838	846	853	861	868	876	884	8
574	891	890	906	914	921	929	937	944	952	959	8
575	967	974	982	988	997	*005	*012	*020	*027	*035	8
576	76 042	050	057	065	072	080	087	095	103	110	8
577	118	125	133	140	148	155	163	170	178	185	8
578	193	200	208	215	223	230	238	245	253	260	8
579	263	275	283	290	298	305	313	320	328	335	8
580	343	350	358	365	373	380	388	395	403	410	8
581	418	425	433	440	448	455	462	470	477	485	7
582	492	500	507	515	522	530	537	545	552	559	7
583	567	574	582	589	597	604	612	619	626	634	7
584	641	649	656	664	671	678	686	693	701	708	7
585	716	723	730	738	745	753	760	768	775	782	7
586	790	797	805	812	819	827	834	842	849	856	7
587	864	871	879	886	893	901	908	916	923	930	7
588	938	945	953	960	967	975	982	989	997	*004	7
589	77 012	019	026	034	041	048	055	063	070	078	7
N	O	1	2	3	4	5	6	7	8	9	D

COMMON LOGARITHMS OF NUMBERS.											
590-629											
N	O	1	2	3	4	5	6	7	8	9	D
590	065	093	100	107	115	122	129	137	144	151	7
591	150	166	173	181	188	195	203	210	217	225	7
592	232	240	247	254	262	269	276	283	291	298	7
593	395	313	320	327	335	343	349	357	364	371	7
594	379	380	393	401	408	415	422	430	437	444	7
595	452	459	466	474	481	488	495	503	510	517	7
596	525	532	539	546	554	561	568	576	583	590	7
597	597	605	612	619	627	634	641	648	656	663	7
598	670	677	685	692	699	706	714	721	728	735	7
599	743	750	757	764	772	779	786	793	801	808	7
600	815	822	830	837	844	851	859	866	873	880	7
601	887	895	902	909	916	924	931	938	945	952	7
602	960	967	974	981	988	995	*002	*010	*017	*025	7
603	78 022	029	046	053	061	068	075	082	089	097	7
604	104	111	118	125	132	140	147	154	161	168	7
605	176	183	190	197	204	211	219	228	233	240	7
606	247	254	262	269	276	283	290	297	305	312	7
607	319	326	333	340	347	355	362	369	376	383	7
608	390	398	405	412	419	426	433	440	447	455	7
609	462	469	476	483	490	497	504	512	519	526	7
610	533	540	547	554	561	569	576	583	590	597	7
611	694	611	618	625	633	640	647	654	661	668	7
612	675	682	689	696	704	711	718	725	732	739	7
613	746	753	760	767	774	781	789	796	803	810	7
614	817	824	831	838	845	852	859	866	873	880	7
615	868	895	902	908	916	923	930	937	944	951	7
616	958	965	972	979	986	993	*000	*007	*014	*021	7
617	79 029	036	043	050	057	064	071	078	085	092	7
618	099	106	113	120	127	134	141	148	155	162	7
619	169	176	183	190	197	204	211	218	225	232	7
620	239	246	253	260	267	274	281	288	295	302	7
621	369	316	323	330	337	344	351	358	365	372	7
622	379	336	393	400	407	414	421	428	435	442	7
623	449	456	463	470	477	484	491	498	505	511	7
624	518	525	532	539	546	553	560	567	574	581	7
625	588	595	602	609	616	623	630	637	644	650	7
626	657	664	671	678	685	692	699	706	713	720	7
627	727	734	741	748	754	761	768	775	782	789	7
628	796	803	810	817	824	831	837	844	851	858	7
629	865	872	879	886	893	900	906	913	920	927	7
N	O	1	2	3	4	5	6	7	8	9	D

COMMON LOGARITHMS OF NUMBERS.											
630-669											
N	O	1	2	3	4	5	6	7	8	9	D
630	934	941	948	955	962	969	975	982	989	996	7
631	80 993	010	017	024	030	037	044	051	058	065	7
632	072	079	085	092	099	106	113	120	127	134	7
633	140	147	154	161	168	175	183	188	195	202	7
634	209	216	223	229	236	243	250	257	264	271	7
635	277	284	291	298	305	312	318	325	332	339	7
636	346	353	359	366	373	380	387	393	400	407	7
637	414	421	428	434	441	448	455	462	468	475	7
638	482	489	496	502	509	516	523	530	536	543	7
639	550	557	564	570	577	584	591	598	604	611	7
640	618	625	632	638	645	652	659	665	672	679	7
641	686	693	699	706	713	720	726	733	740	747	7
642	754	760	767	774	781	787	794	801	808	814	7
643	821	828	835	841	848	855	862	866	875	882	7
644	889	895	902	909	916	922	929	936	943	949	7
645	956	963	969	976	983	990	996	*003	*010	*017	7
646	81 023	030	037	043	050	057	064	070	077	084	7
647	099	097	104	111	117	124	131	137	144	151	7
648	158	164	171	178	184	191	198	204	211	218	7
649	224	231	238	245	251	258	265	271	278	285	7
650	291	298	305	311	318	325	331	338	345	351	7
651	358	365	371	378	385	391	398	405	411	418	7
652	425	431	438	445	451	458	465	471	478	485	7
653	491	498	505	511	518	525	531	538	544	551	7
654	558	564	571	578	584	591	598	604	611	617	7
655	624	631	637	644	651	657	664	671	677	684	7
656	690	697	704	710	717	723	730	737	743	750	7
657	757	763	770	776	783	790	796	803	809	816	7
658	823	829	836	842	849	856	862	869	875	882	7
659	889	895	902	908	915	921	928	935	941	946	7
660	954	961	968	974	981	987	994	*000	*007	*014	7
661	82 029	037	043	049	049	053	060	066	072	079	7
662	086	092	099	105	112	119	125	132	138	145	7
663	151	158	164	171	178	184	191	197	204	210	7
664	217	223	230	236	243	249	256	263	269	276	7
665	282	289	295	302	308	315	321	328	334	341	7
666	347	354	360	367	373	380	387	393	400	406	7
667	413	419	426	432	439	445	452	458	465	471	7
668	478	484	491	497	504	510	517	523	530	536	7
669	543	549	556	562	569	575	582	588	595	601	7
N	O	1	2	3	4	5	6	7	8	9	D

## COMMON LOGARITHMS

Sec. 1

## COMMON LOGARITHMS OF NUMBERS.

670-709

N	O	1	2	3	4	5	6	7	8	9	D
670	607	616	620	627	633	640	646	653	660	666	7
671	672	679	685	692	698	705	711	718	724	730	6
672	737	743	750	756	763	769	776	782	789	795	6
673	802	808	816	821	827	834	840	847	853	860	6
674	865	872	879	885	892	898	905	911	918	924	6
675	930	937	943	950	956	963	969	975	982	988	6
676	995	*001	*006	*014	*020	*027	*033	*040	*046	*052	6
677	83 680	065	072	078	085	091	097	104	110	117	6
678	123	129	136	142	149	155	161	168	174	181	6
679	187	193	200	206	213	219	225	232	238	245	6
680	251	257	264	270	276	283	289	296	302	308	6
681	315	321	327	334	340	347	353	359	366	372	6
682	378	385	391	398	404	410	417	423	429	436	6
683	442	448	455	461	467	474	480	487	493	499	6
684	506	512	518	525	531	537	544	550	556	562	6
685	569	575	582	588	594	601	607	613	620	626	6
686	632	639	645	651	658	664	670	677	683	689	6
687	696	702	708	715	721	727	734	740	746	753	6
688	759	765	771	778	784	790	797	803	809	816	6
689	822	828	835	841	847	853	860	866	872	879	6
690	885	891	897	904	910	916	922	929	935	942	6
691	948	954	960	967	973	979	985	992	998	*004	6
692	84 011	017	023	029	035	042	048	055	061	067	6
693	073	080	086	092	098	105	111	117	123	130	6
694	136	142	148	155	161	167	173	180	186	192	6
695	198	205	211	217	223	230	236	242	248	255	6
696	261	267	273	280	286	292	298	305	311	317	6
697	323	330	336	342	348	354	361	367	373	379	6
698	386	392	398	404	410	417	423	429	435	442	6
699	448	454	460	466	473	479	485	491	497	504	6
700	510	516	522	528	535	541	547	553	559	566	6
701	572	578	584	590	597	603	609	615	621	628	6
702	634	640	646	652	658	665	671	677	683	689	6
703	696	702	708	714	720	726	733	739	745	751	6
704	757	763	770	776	782	788	794	800	807	813	6
705	819	825	831	837	844	850	856	862	868	874	6
706	880	887	893	899	905	911	917	924	930	936	6
707	942	948	954	960	967	973	979	985	991	997	6
708	85 003	609	615	622	628	634	640	646	652	658	6
709	065	071	077	083	089	095	101	107	114	120	6
N	O	1	2	3	4	5	6	7	8	9	D

COMMON LOGARITHMS OF NUMBERS.											
710-749											
N	O	1	2	3	4	5	6	7	8	9	D
710	126	132	138	144	150	156	163	169	175	181	6
711	187	193	199	205	211	217	224	230	236	242	6
712	248	254	260	266	272	278	285	291	297	303	6
713	309	315	321	327	333	339	345	352	358	364	6
714	370	376	382	388	394	400	406	412	418	425	6
715	431	437	443	449	455	461	467	473	479	485	6
716	491	497	503	509	516	522	528	534	540	546	6
717	552	558	564	570	576	582	588	594	599	606	6
718	612	618	625	631	637	643	649	655	661	667	6
719	673	679	685	691	697	703	709	715	721	727	6
720	733	739	745	751	757	763	769	775	781	788	6
721	794	800	809	812	818	824	830	836	842	848	6
722	854	860	869	872	878	884	890	896	902	908	6
723	914	920	926	932	938	944	950	956	962	968	6
724	974	980	985	992	998	*004	*010	*016	*022	*028	6
725	86 064	040	046	052	058	064	070	076	082	088	6
726	094	100	106	112	118	124	130	136	141	147	6
727	158	159	165	171	177	183	189	195	201	207	6
728	213	219	225	231	237	243	249	255	261	267	6
729	273	279	285	291	297	303	308	314	320	326	6
730	332	338	344	350	356	362	368	374	380	386	6
731	392	398	404	410	415	421	427	433	439	445	6
732	451	457	463	469	475	481	487	493	499	504	6
733	510	516	522	528	534	540	546	552	558	564	6
734	570	576	581	587	593	599	605	611	617	623	6
735	629	635	641	646	652	658	664	670	676	682	6
736	688	694	700	705	711	717	723	729	735	741	6
737	747	753	759	764	770	776	782	788	794	799	6
738	806	812	817	823	829	835	841	847	853	859	6
739	864	870	876	882	888	894	900	906	911	917	6
740	923	929	935	941	947	953	958	964	970	976	6
741	982	988	994	999	*005	*011	*017	*023	*029	*035	6
742	87 040	046	052	058	064	070	075	081	087	093	6
743	099	105	111	116	122	128	134	140	146	151	6
744	157	163	169	175	181	186	192	198	204	210	6
745	216	221	227	233	239	245	251	256	262	268	6
746	274	280	286	291	297	303	309	315	320	326	6
747	332	338	344	349	355	361	367	373	379	384	6
748	390	396	402	408	413	419	425	431	437	442	6
749	448	454	460	466	471	477	483	489	495	500	6
N	O	1	2	3	4	5	6	7	8	9	D

## COMMON LOGARITHMS

Sec. 1

COMMON LOGARITHMS OF NUMBERS.											
750-789											
N	O	1	2	3	4	5	6	7	8	9	D
750	506	512	518	523	529	535	541	547	552	558	6
751	564	570	576	581	587	592	599	604	610	616	6
752	622	628	633	639	645	651	656	662	668	674	6
753	679	685	691	697	703	708	714	720	726	731	6
754	737	743	749	754	760	766	772	777	783	789	6
755	795	806	806	812	818	823	829	835	841	846	6
756	852	858	864	869	875	881	887	892	898	904	6
757	910	915	921	927	933	938	944	950	955	961	6
758	967	973	978	984	989	996	*001	*007	*013	*018	6
759	88 024	030	035	041	047	053	058	064	070	075	6
760	081	087	093	098	104	110	116	121	127	133	6
761	138	144	150	156	161	167	173	178	184	190	6
762	195	201	207	213	218	224	230	235	241	247	6
763	252	258	264	270	275	281	287	292	298	304	6
764	309	315	321	326	332	338	343	349	355	360	6
765	366	372	377	383	389	395	400	406	412	417	6
766	423	429	434	440	446	451	457	463	468	474	6
767	480	485	491	497	502	508	513	519	525	530	6
768	536	542	547	553	559	564	570	576	581	587	6
769	593	598	604	610	615	621	627	632	638	643	6
770	649	655	660	666	672	677	683	689	694	700	6
771	705	711	717	722	728	734	739	745	750	756	6
772	762	767	773	779	784	790	795	801	807	812	6
773	818	824	829	835	840	846	852	857	863	868	6
774	874	880	885	891	897	902	908	913	919	925	6
775	930	936	941	947	953	958	964	969	975	981	6
776	996	992	997	*003	*009	*014	*020	*025	*031	*037	6
777	89 042	048	053	059	064	070	076	081	087	092	6
778	098	104	109	115	120	126	131	137	143	148	6
779	154	159	165	170	176	182	187	193	198	204	6
780	209	215	221	226	232	237	243	248	254	260	6
781	265	271	276	282	287	293	298	304	310	315	6
782	321	326	332	337	343	348	354	359	365	371	6
783	376	382	387	393	398	404	409	415	421	426	6
784	432	437	443	448	454	459	465	470	476	481	6
785	487	492	498	504	509	515	520	526	531	537	6
786	542	548	553	559	564	570	575	581	586	592	6
787	597	603	609	614	620	625	631	636	642	647	6
788	653	658	664	669	675	680	686	691	697	702	6
789	708	713	719	724	730	735	741	746	752	757	6
N	O	1	2	3	4	5	6	7	8	9	D

COMMON LOGARITHMS OF NUMBERS.											
790-829											
N	O	1	2	3	4	5	6	7	8	9	D
790	763	768	774	779	785	790	796	801	807	812	5
791	818	823	829	834	840	845	851	856	862	867	5
792	873	878	883	889	894	900	905	911	916	922	5
793	927	933	938	944	949	955	960	966	971	977	5
794	982	988	993	998	*004	*009	*015	*020	*026	*031	5
795	90 037	042	048	053	059	064	069	075	080	086	5
796	091	097	102	108	113	119	124	129	135	140	5
797	146	151	157	162	168	173	179	184	189	195	5
798	200	206	211	217	222	227	233	238	244	249	5
799	255	260	266	271	276	282	287	293	298	304	5
800	309	314	320	325	331	338	342	347	352	358	5
801	363	369	374	380	385	390	396	401	407	412	5
802	417	423	428	434	439	445	450	455	461	466	5
803	472	477	483	488	493	499	504	509	515	520	5
804	526	531	536	542	547	553	558	563	569	574	5
805	580	585	590	596	601	607	612	617	623	628	5
806	634	639	644	650	655	660	666	671	677	682	5
807	687	693	698	703	709	714	720	725	730	736	5
808	741	747	752	757	763	768	773	779	784	789	5
809	795	800	806	811	816	822	827	832	838	843	5
810	849	854	858	865	870	875	881	886	891	897	5
811	902	907	913	918	924	929	934	940	945	950	5
812	956	961	966	972	977	982	988	993	998	*004	5
813	91 009	014	020	025	030	036	041	046	052	057	5
814	062	068	073	078	084	089	094	100	105	110	5
815	116	121	126	132	137	142	148	153	158	164	5
816	169	174	180	185	190	196	201	206	212	217	5
817	222	228	233	238	243	249	254	259	265	270	5
818	275	281	286	291	297	302	307	312	318	323	5
819	328	334	339	344	350	355	360	365	371	376	5
820	381	387	392	397	403	408	413	418	424	429	5
821	434	440	445	450	455	461	466	471	477	482	5
822	487	492	498	503	508	514	519	524	529	535	5
823	540	545	551	556	561	566	572	577	582	587	5
824	593	598	603	609	614	619	624	630	635	640	5
825	645	651	656	661	666	672	677	682	687	693	5
826	698	703	709	714	719	724	730	735	740	745	5
827	751	756	761	766	772	777	782	787	792	798	5
828	803	808	814	819	824	829	834	840	845	850	5
829	855	861	866	871	876	882	887	892	897	903	5
N	O	1	2	3	4	5	5	7	8	9	D

COMMON LOGARITHMS OF NUMBERS.											
830-869											
N	O	1	2	3	4	5	6	7	8	9	D
830	968	913	918	924	929	934	939	944	950	955	5
831	969	965	971	976	981	986	991	997	*002	*007	5
832	92 012	018	023	028	033	038	044	049	054	059	5
833	065	070	075	080	085	090	096	101	106	111	5
834	117	122	127	132	137	143	148	153	158	163	5
835	169	174	179	184	189	195	200	205	210	215	5
836	221	226	231	236	241	247	252	257	262	267	5
837	273	278	283	288	293	298	304	309	314	319	5
838	324	329	335	340	345	350	355	361	366	371	5
839	376	381	387	392	397	402	407	412	418	423	5
840	428	433	438	443	449	454	459	464	469	474	5
841	480	485	490	495	500	505	511	516	521	526	5
842	531	536	542	547	552	557	562	567	572	578	5
843	583	588	593	598	603	609	614	619	624	629	5
844	634	639	645	650	655	660	665	670	675	681	5
845	686	691	696	701	706	711	716	722	727	732	5
846	737	742	747	752	758	763	768	773	778	783	5
847	788	793	799	804	809	814	819	824	829	834	5
848	849	854	859	865	870	875	879	884	889	894	5
849	891	896	901	906	911	916	921	927	932	937	5
850	942	947	952	957	962	967	973	978	983	988	5
851	993	998	*003	*008	*013	*018	*024	*029	*034	*039	5
852	92 044	049	054	059	064	069	075	080	085	090	5
853	095	100	105	110	115	120	125	131	136	141	5
854	146	151	156	161	166	171	176	181	186	192	5
855	197	202	207	212	217	222	227	232	237	242	5
856	247	252	258	263	268	273	278	283	288	293	5
857	298	303	308	313	318	323	329	334	339	344	5
858	349	354	359	364	369	374	379	384	389	394	5
859	399	404	409	414	420	425	430	435	440	445	5
860	450	455	460	465	470	475	480	485	490	495	5
861	500	505	510	515	520	526	531	536	541	546	5
862	551	556	561	566	571	576	581	586	591	596	5
863	601	606	611	616	621	626	631	636	641	646	5
864	651	656	661	666	671	676	682	687	692	697	5
865	702	707	712	717	722	727	732	737	742	747	5
866	752	757	762	767	772	777	782	787	792	797	5
867	802	807	812	817	822	827	832	837	842	847	5
868	852	857	862	867	872	877	882	887	892	897	5
869	902	907	912	917	922	927	932	937	942	947	5
N	O	1	2	3	4	5	6	7	8	9	D



COMMON LOGARITHMS OF NUMBERS.											
870-909											
N	O	1	2	3	4	5	6	7	8	9	D
870	962	957	962	967	972	977	982	987	992	997	5
871	.94 002	007	012	017	022	027	032	037	042	047	5
872	052	057	062	067	072	077	082	086	091	096	5
873	101	106	111	116	121	126	131	136	141	146	5
874	151	156	161	166	171	176	181	186	191	196	5
875	201	206	211	216	221	226	231	236	240	245	5
876	250	255	260	265	270	275	280	285	290	295	5
877	300	305	310	315	320	325	330	335	340	345	5
878	349	354	359	364	369	374	379	384	389	394	5
879	399	404	409	414	419	424	429	433	438	443	5
880	448	453	458	463	468	473	478	483	488	493	5
881	498	503	507	512	517	522	527	532	537	542	5
882	547	552	557	562	567	571	576	581	586	591	5
883	596	601	606	611	616	621	626	630	635	640	5
884	645	650	655	660	665	670	675	680	685	689	5
885	694	699	704	709	714	719	724	729	734	738	5
886	743	748	753	758	763	768	773	778	783	787	5
887	792	797	802	807	812	817	822	827	832	836	5
888	841	846	851	856	861	866	871	876	880	885	5
889	890	895	900	905	910	915	919	924	929	934	5
890	939	944	949	954	959	963	968	973	978	983	5
891	988	993	998	*002	*007	*012	*017	*022	*027	*032	5
892	.95 036	041	046	051	056	061	066	071	075	080	5
893	085	090	095	100	105	109	114	119	124	129	5
894	134	139	143	148	153	158	163	168	173	177	5
895	182	187	192	197	202	207	211	216	221	226	5
896	231	236	240	245	250	255	260	265	270	274	5
897	279	284	289	294	299	303	308	313	318	323	5
898	328	332	337	342	347	352	357	361	366	371	5
899	376	381	386	390	395	400	406	410	415	419	5
900	424	429	434	439	444	448	453	458	463	468	5
901	472	477	482	487	492	497	501	506	511	516	5
902	521	525	530	535	540	545	550	554	559	564	5
903	569	574	578	583	588	593	598	602	607	612	5
904	617	622	626	631	636	641	646	650	655	660	5
905	665	670	674	679	684	689	694	698	703	708	5
906	713	718	722	727	732	737	742	746	751	756	5
907	761	766	770	775	780	785	789	794	799	804	5
908	809	813	818	823	828	833	837	842	847	852	5
909	856	861	866	871	875	880	885	890	895	899	5
N	O	1	2	3	4	5	6	7	8	9	D

## COMMON LOGARITHMS OF NUMBERS.

910-949

N	O	1	2	3	4	5	6	7	8	9	D
910	904	069	914	918	923	928	933	938	942	947	5
911	952	957	961	966	971	976	980	985	990	995	5
912	999	*004	*009	*014	*019	*023	*028	*033	*038	*042	5
913	96	047	052	057	061	066	071	076	080	085	5
914	085	099	104	109	114	118	123	128	133	137	5
915	142	147	152	156	161	166	171	175	180	185	5
916	190	194	199	204	209	213	218	223	227	232	5
917	237	242	246	251	256	261	265	270	275	280	5
918	284	289	294	298	303	308	313	317	322	327	5
919	332	336	341	346	350	355	360	365	369	374	5
920	379	384	388	393	398	402	407	412	417	421	5
921	426	431	435	440	445	450	454	459	464	468	5
922	473	478	483	487	492	497	501	506	511	515	5
923	520	525	530	534	539	544	548	553	558	562	5
924	567	572	577	581	586	591	595	600	605	609	5
925	614	619	624	628	633	638	642	647	652	656	5
926	661	666	670	675	680	685	689	694	699	703	5
927	708	713	717	722	727	731	736	741	745	750	5
928	755	759	764	769	774	778	783	788	792	797	5
929	802	806	811	816	820	825	830	834	839	844	5
930	843	853	858	862	867	872	876	881	886	891	5
931	895	900	904	909	914	918	923	928	932	937	5
932	942	948	951	956	960	965	970	974	979	984	5
933	988	993	997	*002	*007	*011	*016	*021	*025	*030	5
934	97	035	039	044	049	053	058	063	067	072	5
935	061	066	070	075	080	085	090	094	099	104	5
936	128	132	137	142	146	151	155	160	165	169	5
937	174	179	183	188	192	197	202	206	211	216	5
938	220	225	230	234	239	243	248	253	257	262	5
939	267	271	276	280	285	290	294	299	304	308	5
940	313	317	322	327	331	336	340	345	350	354	5
941	359	364	368	373	377	382	387	391	396	400	5
942	405	410	414	419	424	428	433	437	442	447	5
943	451	456	460	465	470	474	479	483	488	493	5
944	497	502	506	511	516	520	525	529	534	539	5
945	543	548	552	557	562	566	571	575	580	585	5
946	589	594	598	603	607	612	617	621	626	630	5
947	635	640	644	649	653	658	663	667	672	676	5
948	681	685	690	695	699	704	708	713	717	722	5
949	727	731	736	740	745	749	754	759	763	768	5
N	O	1	2	3	4	5	6	7	8	9	D

COMMON LOGARITHMS OF NUMBERS.											
950-989											
N	O	1	2	3	4	5	6	7	8	9	D
950	772	777	782	786	791	795	800	804	809	813	5
951	818	823	827	832	836	841	845	850	855	859	5
952	864	868	873	877	882	886	891	896	900	905	5
953	909	914	918	923	928	932	937	941	946	950	5
954	955	959	964	968	973	978	982	987	991	996	5
955	96 000	005	009	014	019	023	028	032	037	041	5
956	046	050	055	059	064	068	073	078	082	087	5
957	091	096	100	105	109	114	118	123	127	132	5
958	137	141	146	150	155	159	164	168	173	177	5
959	182	186	191	195	200	204	209	214	218	223	5
960	227	232	236	241	245	250	254	259	263	268	5
961	272	277	281	286	290	295	299	304	308	313	5
962	318	322	327	331	336	340	345	349	354	358	5
963	363	367	372	376	381	385	390	394	399	403	5
964	408	412	417	421	426	430	435	439	444	448	5
965	453	457	462	466	471	475	480	484	489	493	4
966	498	502	507	511	516	520	525	529	534	538	4
967	543	547	552	556	561	565	570	574	579	583	4
968	588	592	597	601	605	610	614	619	623	628	4
969	632	637	641	646	650	655	659	664	668	673	4
970	677	682	688	691	695	700	704	709	713	717	4
971	722	726	731	735	740	744	749	753	758	762	4
972	767	771	776	780	784	789	793	798	802	807	4
973	811	816	820	825	829	834	838	843	847	851	4
974	856	860	865	869	874	878	883	887	892	896	4
975	900	905	909	914	918	923	927	932	936	941	4
976	945	949	954	958	963	967	972	976	981	985	4
977	989	994	998	*003	*007	*012	*016	*021	*025	*029	4
978	99 034	038	042	047	052	056	061	065	069	074	4
979	078	083	087	092	096	100	105	109	114	118	4
980	123	127	131	136	140	145	149	154	158	162	4
981	167	171	176	180	185	189	193	198	202	207	4
982	211	216	220	224	229	233	236	242	247	251	4
983	255	260	264	269	273	277	282	286	291	295	4
984	299	304	308	313	317	322	326	330	335	339	4
985	344	348	352	357	361	366	370	374	379	383	4
986	388	392	396	401	405	410	414	419	423	427	4
987	432	436	441	445	449	454	458	463	467	471	4
988	476	480	484	489	493	498	502	506	511	515	4
989	520	524	528	533	537	542	546	550	555	559	4
N	O	1	2	3	4	5	6	7	8	9	D

## COMMON LOGARITHMS OF NUMBERS.

990-999

N	O	1	2	3	4	5	6	7	8	9	D
990	504	566	572	577	581	585	599	594	599	606	4
991	607	612	616	621	625	629	634	638	642	647	4
992	651	656	660	664	660	673	677	682	686	691	4
993	695	699	704	708	712	717	721	726	730	734	4
994	739	743	747	752	756	760	765	769	774	778	4
995	782	787	791	795	800	804	808	813	817	822	4
996	826	830	835	839	843	848	852	856	861	865	4
997	870	874	878	883	887	891	896	900	904	909	4
998	913	917	922	926	930	935	939	944	948	952	4
999	957	961	965	970	974	978	983	987	991	996	4
N	O	1	2	3	4	5	6	7	8	9	D



**TABLE 2**

**NATURAL TRIGONOMETRIC FUNCTIONS**

Sec. 1 NATURAL TRIGONOMETRIC FUNCTIONS

FOUR-PLACE VALUES OF TRIGONOMETRIC FUNCTIONS.					
° ' /	N. Sin.	N. Tan.	N. Cot.	N. Cos.	' °
0 00	.0000	.0000	∞	1.0000	00 90
10	.0029	.0029	343.77	1.0000	50
20	.0058	.0058	171.89	1.0000	40
30	.0097	.0097	114.59	1.0000	30
40	.0116	.0116	85.940	.9999	20
50	.0145	.0145	68.750	.9999	10
1 00	.0175	.0175	57.290	.9998	00 89
10	.0204	.0204	49.104	.9998	50
20	.0233	.0233	42.964	.9997	40
30	.0262	.0262	38.188	.9997	30
40	.0291	.0291	34.368	.9996	20
50	.0320	.0320	31.242	.9995	10
2 00	.0349	.0349	28.636	.9994	00 88
10	.0378	.0378	26.432	.9993	50
20	.0407	.0407	24.542	.9992	40
30	.0436	.0437	22.904	.9991	30
40	.0465	.0466	21.470	.9989	20
50	.0494	.0495	20.206	.9988	10
3 00	.0523	.0524	19.081	.9986	00 87
10	.0552	.0553	18.075	.9985	50
20	.0581	.0582	17.169	.9984	40
30	.0610	.0612	16.350	.9981	30
40	.0640	.0641	15.605	.9980	20
50	.0669	.0670	14.924	.9978	10
4 00	.0698	.0699	14.301	.9976	00 86
10	.0727	.0729	13.727	.9974	50
20	.0756	.0758	13.197	.9971	40
30	.0785	.0787	12.706	.9969	30
40	.0814	.0816	12.251	.9967	20
50	.0843	.0846	11.826	.9964	10
5 00	.0872	.0875	11.439	.9962	00 85
10	.0901	.0904	11.089	.9959	50
20	.0929	.0934	10.712	.9957	40
30	.0958	.0963	10.385	.9954	30
40	.0987	.0992	10.078	.9951	20
50	.1016	.1022	9.7882	.9948	10
6 00	.1045	.1051	9.5144	.9945	00 84
10	.1074	.1080	9.2553	.9942	50
20	.1103	.1110	9.0098	.9939	40
30	.1132	.1139	8.7769	.9936	30
40	.1161	.1169	8.5555	.9932	20
50	.1190	.1198	8.3450	.9929	10
7 00	.1219	.1228	8.1443	.9925	00 83
10	.1248	.1257	7.9530	.9922	50
20	.1276	.1287	7.7704	.9918	40
30	.1305	.1317	7.5958	.9914	30
40	.1334	.1346	7.4287	.9911	20
50	.1363	.1376	7.2687	.9907	10
	N. Cos.	N. Cot.	N. Tan.	N. Sin.	' °

NATURAL TRIGONOMETRIC FUNCTIONS Sec. 1

FOUR-PLACE VALUES OF TRIGONOMETRIC FUNCTIONS.					
° /	N. Sin.	N. Tan.	N. Cot.	N. Cos.	
8 00	.1392	.1465	7.1154	.9903	00 82
10	.1421	.1435	6.9683	.9899	50
20	.1449	.1445	6.8269	.9894	40
30	.1478	.1485	6.6912	.9889	30
40	.1507	.1524	6.5606	.9889	20
50	.1536	.1554	6.4348	.9881	10
9 00	.1564	.1584	6.3138	.9877	00 81
10	.1593	.1614	6.1970	.9872	50
20	.1622	.1644	6.0844	.9868	40
30	.1650	.1673	5.9758	.9863	30
40	.1679	.1703	5.8708	.9858	20
50	.1708	.1733	5.7694	.9853	10
10 00	.1736	.1763	5.6712	.9848	00 80
10	.1765	.1793	5.5764	.9843	50
20	.1794	.1823	5.4845	.9838	40
30	.1822	.1853	5.3955	.9833	30
40	.1851	.1883	5.3093	.9827	20
50	.1880	.1914	5.2257	.9822	10
11 00	.1908	.1944	5.1445	.9816	00 79
10	.1937	.1974	5.0658	.9811	50
20	.1965	.2004	4.9894	.9806	40
30	.1994	.2035	4.9152	.9799	30
40	.2022	.2065	4.8430	.9793	20
50	.2051	.2095	4.7729	.9787	10
12 00	.2079	.2126	4.7045	.9781	00 78
10	.2108	.2156	4.6382	.9775	50
20	.2136	.2186	4.5736	.9769	40
30	.2164	.2217	4.5107	.9763	30
40	.2193	.2267	4.4494	.9757	20
50	.2221	.2318	4.3897	.9750	10
13 00	.2250	.2300	4.3315	.9744	00 77
10	.2278	.2300	4.2747	.9737	50
20	.2306	.2370	4.2193	.9730	40
30	.2334	.2401	4.1653	.9724	30
40	.2362	.2432	4.1126	.9717	20
50	.2391	.2462	4.0611	.9710	10
14 00	.2419	.2482	4.0108	.9703	00 76
10	.2447	.2524	3.9617	.9696	50
20	.2475	.2555	3.9136	.9689	40
30	.2504	.2586	3.8667	.9681	30
40	.2532	.2617	3.8208	.9674	20
50	.2560	.2648	3.7760	.9667	10
15 00	.2588	.2679	3.7321	.9660	00 75
10	.2616	.2711	3.6891	.9652	50
20	.2644	.2742	3.6470	.9644	40
30	.2672	.2773	3.6059	.9636	30
40	.2700	.2805	3.5656	.9628	20
50	.2728	.2826	3.5261	.9621	10
	N. Cos.	N. Cot.	N. Tan.	N. Sin.	°



Sec. 1 NATURAL TRIGONOMETRIC FUNCTIONS

FOUR-PLACE VALUES OF TRIGONOMETRIC FUNCTIONS.					
° /	N. Sin.	N. Tan.	N. Cot.	N. Cos.	
16 00	.2766	.2867	3.4874	.9613	00 74
10	.2784	.2899	3.4495	.9605	50
20	.2812	.2931	3.4124	.9596	40
30	.2840	.2982	3.3759	.9588	30
40	.2868	.2994	3.3402	.9580	20
50	.2896	.3026	3.3062	.9572	10
17 00	.2924	.3067	3.2709	.9563	00 73
10	.2952	.3098	3.2371	.9555	50
20	.2979	.3121	3.2041	.9546	40
30	.3007	.3153	3.1718	.9537	30
40	.3035	.3185	3.1397	.9528	20
50	.3062	.3217	3.1064	.9520	10
18 00	.3090	.3249	3.0777	.9511	00 72
10	.3118	.3281	3.0475	.9502	50
20	.3145	.3314	3.0178	.9492	40
30	.3173	.3346	2.9887	.9483	30
40	.3201	.3378	2.9600	.9474	20
50	.3228	.3411	2.9319	.9465	10
19 00	.3256	.3443	2.9042	.9455	00 71
10	.3283	.3476	2.8770	.9446	50
20	.3311	.3508	2.8502	.9436	40
30	.3338	.3541	2.8239	.9426	30
40	.3365	.3574	2.7980	.9417	20
50	.3393	.3607	2.7725	.9407	10
20 00	.3420	.3640	2.7475	.9397	00 70
10	.3448	.3673	2.7228	.9387	50
20	.3475	.3706	2.6985	.9377	40
30	.3502	.3739	2.6746	.9367	30
40	.3529	.3772	2.6511	.9356	20
50	.3557	.3805	2.6279	.9346	10
21 00	.3584	.3839	2.6051	.9336	00 69
10	.3611	.3872	2.5826	.9325	50
20	.3638	.3906	2.5605	.9315	40
30	.3665	.3939	2.5386	.9304	30
40	.3692	.3973	2.5172	.9293	20
50	.3719	.4006	2.4960	.9283	10
22 00	.3746	.4040	2.4751	.9272	00 68
10	.3773	.4074	2.4545	.9261	50
20	.3800	.4106	2.4342	.9250	40
30	.3827	.4142	2.4142	.9239	30
40	.3854	.4176	2.3945	.9228	20
50	.3881	.4210	2.3750	.9216	10
23 00	.3907	.4245	2.3559	.9205	00 67
10	.3934	.4279	2.3369	.9194	50
20	.3961	.4314	2.3183	.9182	40
30	.3987	.4348	2.2998	.9171	30
40	.4014	.4383	2.2817	.9159	20
50	.4041	.4417	2.2637	.9147	10
	N. Cos.	N. Cot.	N. Tan.	N. Sin.	° /

NATURAL TRIGONOMETRIC FUNCTIONS Sec. 1

FOUR-PLACE VALUES OF TRIGONOMETRIC FUNCTIONS.						
°	'	N. Sin.	N. Tan.	N. Cot.	N. Cos.	
24	00	.4067	.4452	2.2469	.9125	00 66
	10	.4094	.4487	2.2296	.9124	50
	20	.4120	.4522	2.2112	.9112	40
	30	.4147	.4557	2.1942	.9100	30
	40	.4173	.4592	2.1775	.9088	20
	50	.4200	.4628	2.1609	.9075	10
25	00	.4226	.4663	2.1445	.9062	00 65
	10	.4253	.4698	2.1282	.9061	50
	20	.4279	.4734	2.1122	.9063	40
	30	.4296	.4770	2.0965	.9026	30
	40	.4311	.4803	2.0809	.9013	20
	50	.4328	.4841	2.0645	.9001	10
26	00	.4354	.4877	2.0503	.8988	00 64
	10	.4410	.4913	2.0353	.8975	50
	20	.4436	.4950	2.0204	.8962	40
	30	.4462	.4986	2.0057	.8949	30
	40	.4486	.5022	1.9912	.8936	20
	50	.4514	.5059	1.9768	.8923	10
27	00	.4540	.5095	1.9626	.8910	00 63
	10	.4566	.5132	1.9486	.8907	50
	20	.4592	.5169	1.9347	.8894	40
	30	.4617	.5206	1.9210	.8870	30
	40	.4643	.5243	1.9074	.8857	20
	50	.4669	.5280	1.8940	.8843	10
28	00	.4695	.5317	1.8807	.8830	00 62
	10	.4720	.5354	1.8676	.8816	50
	20	.4745	.5392	1.8546	.8802	40
	30	.4772	.5430	1.8418	.8788	30
	40	.4797	.5467	1.8291	.8774	20
	50	.4823	.5505	1.8165	.8760	10
29	00	.4848	.5543	1.8040	.8746	00 61
	10	.4874	.5581	1.7917	.8732	50
	20	.4899	.5619	1.7796	.8718	40
	30	.4924	.5658	1.7675	.8704	30
	40	.4950	.5696	1.7556	.8689	20
	50	.4975	.5735	1.7437	.8675	10
30	00	.5000	.5774	1.7321	.8660	00 60
	10	.5025	.5812	1.7205	.8646	50
	20	.5050	.5851	1.7090	.8631	40
	30	.5075	.5890	1.6977	.8616	30
	40	.5100	.5929	1.6864	.8601	20
	50	.5125	.5969	1.6753	.8587	10
31	00	.5150	.6009	1.6643	.8572	00 59
	10	.5175	.6048	1.6534	.8557	50
	20	.5200	.6088	1.6426	.8542	40
	30	.5225	.6128	1.6319	.8526	30
	40	.5250	.6168	1.6212	.8511	20
	50	.5275	.6208	1.6107	.8496	10
		N. Cos.	N. Cot.	N. Tan.	N. Sin.	' °

Sec. 1 NATURAL TRIGONOMETRIC FUNCTIONS

FOUR-PLACE VALUES OF TRIGONOMETRIC FUNCTIONS.					
° /	N. Sin.	N. Tan.	N. Cot.	N. Cos.	
32 00	.5299	.6249	1.6003	.8480	00 58
10	.5324	.6289	1.5900	.8465	50
20	.5348	.6330	1.5798	.8450	40
30	.5373	.6371	1.5697	.8434	30
40	.5398	.6412	1.5597	.8418	20
50	.5422	.6453	1.5497	.8403	10
33 00	.5446	.6494	1.5399	.8387	00 57
10	.5471	.6536	1.5301	.8371	50
20	.5495	.6577	1.5204	.8355	40
30	.5519	.6619	1.5108	.8339	30
40	.5544	.6661	1.5013	.8323	20
50	.5568	.6703	1.4919	.8307	10
34 00	.5592	.6745	1.4826	.8290	00 56
10	.5616	.6787	1.4733	.8274	50
20	.5640	.6830	1.4641	.8258	40
30	.5664	.6873	1.4550	.8241	30
40	.5688	.6916	1.4460	.8225	20
50	.5712	.6959	1.4370	.8208	10
35 00	.5735	.7002	1.4281	.8192	00 55
10	.5760	.7046	1.4193	.8175	50
20	.5783	.7089	1.4106	.8158	40
30	.5807	.7133	1.4019	.8141	30
40	.5831	.7177	1.3934	.8124	20
50	.5854	.7221	1.3848	.8107	10
36 00	.5878	.7265	1.3764	.8090	00 54
10	.5901	.7310	1.3680	.8073	50
20	.5925	.7355	1.3597	.8056	40
30	.5948	.7400	1.3514	.8039	30
40	.5972	.7445	1.3432	.8021	20
50	.5995	.7490	1.3351	.8004	10
37 00	.6018	.7536	1.3270	.7986	00 53
10	.6041	.7581	1.3190	.7969	50
20	.6065	.7627	1.3111	.7951	40
30	.6088	.7673	1.3032	.7934	30
40	.6111	.7720	1.2954	.7916	20
50	.6134	.7766	1.2876	.7898	10
38 00	.6157	.7813	1.2799	.7880	00 52
10	.6180	.7860	1.2723	.7862	50
20	.6202	.7907	1.2647	.7844	40
30	.6225	.7954	1.2572	.7826	30
40	.6248	.8002	1.2497	.7808	20
50	.6271	.8050	1.2423	.7790	10
39 00	.6293	.8098	1.2349	.7771	00 51
10	.6316	.8146	1.2276	.7753	50
20	.6338	.8195	1.2203	.7735	40
30	.6361	.8243	1.2131	.7716	30
40	.6383	.8292	1.2059	.7698	20
50	.6406	.8342	1.1988	.7679	10
	N. Cos.	N. Cot.	N. Tan.	N. Sin.	°

NATURAL TRIGONOMETRIC FUNCTIONS    Sec. 1

FOUR-PLACE VALUES OF TRIGONOMETRIC FUNCTIONS.					
° /	N. Sin.	N. Tan.	N. Cot.	N. Cos.	
40 00	.6428	.8391	1.1918	.7600	00 50
10	.6450	.8441	1.1847	.7642	50
20	.6472	.8491	1.1778	.7683	40
30	.6494	.8541	1.1708	.7694	30
40	.6517	.8591	1.1640	.7685	20
50	.6539	.8642	1.1571	.7666	10
41 00	.6561	.8693	1.1504	.7647	00 49
10	.6583	.8744	1.1436	.7628	50
20	.6604	.8796	1.1369	.7609	40
30	.6626	.8847	1.1302	.7590	30
40	.6648	.8898	1.1237	.7470	20
50	.6670	.8952	1.1171	.7451	10
42 00	.6691	.9004	1.1106	.7431	00 48
10	.6713	.9057	1.1041	.7412	50
20	.6734	.9110	1.0977	.7392	40
30	.6756	.9163	1.0913	.7373	30
40	.6777	.9217	1.0850	.7353	20
50	.6799	.9271	1.0786	.7333	10
43 00	.6820	.9325	1.0724	.7314	00 47
10	.6841	.9380	1.0661	.7294	50
20	.6862	.9435	1.0599	.7274	40
30	.6884	.9490	1.0538	.7254	30
40	.6905	.9545	1.0477	.7234	20
50	.6926	.9601	1.0416	.7214	10
44 00	.6947	.9657	1.0355	.7193	00 46
10	.6967	.9713	1.0295	.7173	50
20	.6988	.9770	1.0235	.7153	40
30	.7009	.9827	1.0176	.7133	30
40	.7030	.9884	1.0117	.7112	20
50	.7050	.9942	1.0058	.7092	10
45 00	.7071	1.0000	1.0000	.7071	00 45
	N. Cos.	N. Cot.	N. Tan.	N. Sin.	/ °



**TABLE No. 3**  
**DECIMAL EQUIVALENTS AND CIRCUMFERENCES**  
**AND AREAS OF CIRCLES**

## DECIMAL EQUIVALENTS OF 64ths

The decimal fractions printed in large type give the exact value of the corresponding fraction to the fourth decimal place. A given decimal fraction is rarely exactly equal to any of these values, and the numbers in small type show which common fraction is nearest to the given decimal. Thus, lay off the fraction 0.1330 in 64ths. The nearest decimal fractions are 0.1250 and 0.1406. The value of any fraction in small type is the mean of the two adjacent fractions. In this instance the mean fraction is 0.1328, and as 0.1330 is greater than this, 0.1406 or  $\frac{9}{64}$  will be chosen. In the same manner the nearest 64ths corresponding to the decimal fractions 0.3670 and 0.8979 are found to be  $\frac{23}{64}$  and  $\frac{57}{64}$ , respectively.

Fraction.	Decimal.	Fraction.	Decimal.	Fraction.	Decimal.	Fraction.	Decimal.
	.0078		.2578		.5078		.7578
$\frac{1}{128}$	.0156	$\frac{1}{16}$	.2856	$\frac{1}{16}$	.5156	$\frac{1}{16}$	.7856
	.0235		.2735		.5235		.7735
$\frac{1}{32}$	.0313	$\frac{1}{8}$	.2813	$\frac{1}{8}$	.5313	$\frac{1}{8}$	.7813
	.0391		.2891		.5391		.7891
$\frac{1}{16}$	.0489	$\frac{1}{4}$	.2969	$\frac{1}{4}$	.5489	$\frac{1}{4}$	.7969
	.0547		.3047		.5547		.8047
$\frac{1}{8}$	.0625	$\frac{3}{8}$	.3125	$\frac{3}{8}$	.5625	$\frac{3}{8}$	.8125
	.0703		.3203		.5703		.8203
$\frac{1}{4}$	.0781	$\frac{1}{2}$	.3281	$\frac{1}{2}$	.5781	$\frac{1}{2}$	.8281
	.0860		.3360		.5860		.8360
$\frac{1}{8}$	.0938	$\frac{5}{8}$	.3438	$\frac{5}{8}$	.5938	$\frac{5}{8}$	.8438
	.1016		.3516		.6016		.8516
$\frac{1}{16}$	.1094	$\frac{3}{4}$	.3594	$\frac{3}{4}$	.6094	$\frac{3}{4}$	.8594
	.1172		.3672		.6172		.8672
$\frac{1}{32}$	.1250	$\frac{7}{8}$	.3750	$\frac{7}{8}$	.6250		.8750
	.1328		.3828		.6328		.8828
$\frac{1}{64}$	.1406	$\frac{1}{2}$	.3906	$\frac{1}{2}$	.6406	$\frac{1}{2}$	.8906
	.1485		.3985		.6485		.8985
$\frac{1}{16}$	.1563	$\frac{3}{8}$	.4063	$\frac{3}{8}$	.6563	$\frac{3}{8}$	.9063
	.1641		.4141		.6641		.9141
$\frac{1}{8}$	.1719	$\frac{1}{4}$	.4219	$\frac{1}{4}$	.6719	$\frac{1}{4}$	.9219
	.1797		.4297		.6797		.9297
$\frac{1}{16}$	.1875	$\frac{5}{8}$	.4375	$\frac{5}{8}$	.6875	$\frac{5}{8}$	.9375
	.1953		.4453		.6953		.9453
$\frac{1}{32}$	.2031	$\frac{1}{2}$	.4531	$\frac{1}{2}$	.7031	$\frac{1}{2}$	.9531
	.2110		.4610		.7110		.9610
$\frac{1}{16}$	.2188	$\frac{3}{8}$	.4688	$\frac{3}{8}$	.7188	$\frac{3}{8}$	.9688
	.2266		.4766		.7266		.9766
$\frac{1}{8}$	.2344	$\frac{1}{4}$	.4844	$\frac{1}{4}$	.7344	$\frac{1}{4}$	.9844
	.2422		.4922		.7422		.9922
$\frac{1}{16}$	.2500	$\frac{1}{2}$	.5000	$\frac{1}{2}$	.7500	1	1.0000
	.2578		.5078		.7578		

CIRCUMFERENCES AND AREAS OF CIRCLES.					
Diam.	Circum.	Area.	Diam.	Circum.	Area.
$\frac{1}{4}$	.6411	.6082	$4\frac{1}{2}$	13.7445	15.0330
$\frac{1}{2}$	.6962	.6600	$4\frac{1}{2}$	14.1372	15.5043
$\frac{3}{4}$	.7513	.6921	$4\frac{1}{2}$	14.5299	16.0082
$1\frac{1}{4}$	.8027	.7123	$4\frac{1}{2}$	14.9226	17.7206
$1\frac{1}{2}$	.8590	.7376	$4\frac{1}{2}$	15.3153	18.6555
$1\frac{3}{4}$	.9154	.7631	5	15.7080	19.0850
$2\frac{1}{4}$	.9617	.7767	$5\frac{1}{2}$	16.1007	20.6230
$2\frac{1}{2}$	1.1761	.1104	$5\frac{1}{2}$	16.4934	21.6476
$2\frac{3}{4}$	1.3744	.1503	$5\frac{1}{2}$	16.8861	22.6967
$3\frac{1}{4}$	1.5708	.1963	$5\frac{1}{2}$	17.2788	23.7583
$3\frac{1}{2}$	1.7671	.2485	$5\frac{1}{2}$	17.6715	24.8505
$3\frac{3}{4}$	1.9635	.3068	$5\frac{1}{2}$	18.0642	25.9673
$4\frac{1}{4}$	2.1598	.3712	$5\frac{1}{2}$	18.4569	27.1006
$4\frac{1}{2}$	2.3562	.4418	6	18.8496	28.2744
$4\frac{3}{4}$	2.5525	.5185	6	19.2423	29.4648
$5\frac{1}{4}$	2.7489	.6013	$6\frac{1}{2}$	19.6350	30.6797
$5\frac{1}{2}$	2.9452	.6903	$6\frac{1}{2}$	20.0277	31.9191
$5\frac{3}{4}$	3.1415	.7854	$6\frac{1}{2}$	20.4204	33.1831
6	3.3378	.8940	$6\frac{1}{2}$	20.8131	34.4717
$6\frac{1}{4}$	3.5341	1.0272	$6\frac{1}{2}$	21.2058	35.7848
$6\frac{1}{2}$	4.1397	1.4849	$6\frac{1}{2}$	21.5985	37.1234
$6\frac{3}{4}$	4.7124	1.7671	7	21.9912	38.4849
$7\frac{1}{4}$	5.1861	2.0739	$7\frac{1}{2}$	22.3839	39.8713
$7\frac{1}{2}$	5.4978	2.4653	$7\frac{1}{2}$	22.7766	41.2836
$7\frac{3}{4}$	5.6905	2.7612	7	23.1693	42.7184
8	6.2832	3.1415	$7\frac{1}{2}$	23.5620	44.1787
$8\frac{1}{4}$	6.6759	3.5466	$7\frac{1}{2}$	23.9547	45.6636
$8\frac{1}{2}$	7.0686	3.9761	$7\frac{1}{2}$	24.3474	47.1731
$8\frac{3}{4}$	7.4613	4.4301	$7\frac{1}{2}$	24.7401	48.7071
9	7.8540	4.9077	8	25.1328	50.2656
$9\frac{1}{4}$	8.2467	5.4119	$8\frac{1}{2}$	25.5255	51.8487
$9\frac{1}{2}$	8.6394	5.9396	$8\frac{1}{2}$	25.9182	53.4563
$9\frac{3}{4}$	9.0321	6.4918	$8\frac{1}{2}$	26.3109	55.0894
10	9.4248	7.0686	$8\frac{1}{2}$	26.7036	56.7451
$10\frac{1}{4}$	9.8175	7.6699	$8\frac{1}{2}$	27.0963	58.4264
$10\frac{1}{2}$	10.2102	8.2953	$8\frac{1}{2}$	27.4890	60.1322
$10\frac{3}{4}$	10.6029	8.9452	$8\frac{1}{2}$	27.8817	61.8635
11	10.9956	9.6211	9	28.2744	63.6174
$11\frac{1}{4}$	11.3883	10.3206	$9\frac{1}{2}$	28.6671	65.3968
$11\frac{1}{2}$	11.7810	11.0447	$9\frac{1}{2}$	29.0598	67.2006
$11\frac{3}{4}$	12.1737	11.7933	$9\frac{1}{2}$	29.4525	69.0293
12	12.5664	12.5664	$9\frac{1}{2}$	29.8452	70.8823
$12\frac{1}{4}$	12.9591	13.3641	$9\frac{1}{2}$	30.2379	72.7599
$12\frac{1}{2}$	13.3518	14.1863	$9\frac{1}{2}$	30.6306	74.6621



CIRCUMFERENCES AND AREAS OF CIRCLES.					
Diam.	Circum.	Area.	Diam.	Circum.	Area.
9½	31.0233	76.589	15½	48.3021	185.661
10	31.4159	78.540	15¾	48.6948	188.632
10¼	31.8087	80.516	15⅞	49.0875	191.748
10½	32.2014	82.516	15⅝	49.4802	194.828
10¾	32.5941	84.541	15¾	49.8729	197.933
10⅞	32.9868	86.590	16	50.2656	201.062
10⅝	33.3795	88.664	16¼	50.6583	204.216
10½	33.7722	90.763	16½	51.0510	207.395
10¾	34.1649	92.886	16⅞	51.4437	210.598
11	34.5576	95.033	16¾	51.8364	213.825
11¼	34.9503	97.205	16⅝	52.2291	217.077
11½	35.3430	99.402	16½	52.6218	220.354
11¾	35.7357	101.623	16¾	53.0145	223.655
11⅞	36.1284	103.869	17	53.4072	226.981
11⅝	36.5211	106.139	17¼	53.7999	230.331
11½	36.9138	108.434	17½	54.1926	233.706
11¾	37.3065	110.754	17⅞	54.5853	237.105
12	37.6992	113.098	17¾	54.9780	240.529
12¼	38.0919	115.466	17⅝	55.3707	243.977
12½	38.4846	117.859	17½	55.7634	247.450
12¾	38.8773	120.277	17¾	56.1561	250.948
12⅞	39.2700	122.719	18	56.5488	254.470
12⅝	39.6627	125.185	18¼	56.9415	258.016
12½	40.0554	127.677	18½	57.3342	261.587
12¾	40.4481	130.192	18¾	57.7269	265.183
13	40.8408	132.733	18⅞	58.1196	268.803
13¼	41.2335	135.297	18¾	58.5123	272.448
13½	41.6262	137.887	18½	58.9050	276.117
13¾	42.0189	140.501	18¾	59.2977	279.811
13⅞	42.4116	143.139	19	59.6904	283.529
13⅝	42.8043	145.802	19¼	60.0831	287.272
13½	43.1970	148.490	19½	60.4758	291.040
13¾	43.5897	151.202	19¾	60.8685	294.832
14	43.9824	153.938	19⅞	61.2612	298.648
14¼	44.3751	156.700	19¾	61.6539	302.489
14½	44.7678	159.485	19½	62.0466	306.355
14¾	45.1605	162.296	19¾	62.4393	310.245
14⅞	45.5532	165.130	20	62.8320	314.160
14⅝	45.9459	167.990	20¼	63.2247	318.099
14½	46.3386	170.874	20½	63.6174	322.063
14¾	46.7313	173.782	20¾	64.0101	326.051
15	47.1240	176.715	20⅞	64.4028	330.064
15¼	47.5167	179.673	20¾	64.7955	334.102
15½	47.9094	182.655	20½	65.1882	338.164

CIRCUMFERENCES AND AREAS OF CIRCLES.					
Diam.	Circum.	Area.	Diam.	Circum.	Area.
20½	65.5000	342.250	26½	82.8897	546.256
21	65.9736	346.361	26¾	83.2834	551.547
21½	66.3663	350.497	26⅞	83.6461	556.763
21¾	66.7590	354.657	26⅞	84.0078	562.002
21½	67.1517	358.842	26¾	84.4906	567.267
21¾	67.5444	363.051	27	84.8332	572.557
21¾	67.9371	367.285	27½	85.2169	577.870
21¾	68.3298	371.543	27½	85.6003	583.200
21¾	68.7225	375.826	27¾	86.0013	588.571
22	69.1153	380.134	27¾	86.3940	593.960
22½	69.5079	384.466	27¾	86.7867	599.371
22½	69.9006	388.823	27¾	87.1794	604.807
22½	70.2933	393.203	27¾	87.5721	610.268
22½	70.6860	397.609	28	87.9648	615.754
22½	71.0787	402.043	28½	88.3575	621.264
22½	71.4714	406.494	28½	88.7502	626.796
22½	71.8641	410.972	28½	89.1429	632.357
23	72.2568	415.477	28½	89.5356	637.941
23½	72.6495	420.004	28½	89.9283	643.549
23½	73.0422	424.558	28½	90.3210	649.182
23½	73.4349	429.135	28½	90.7137	654.840
23½	73.8276	433.737	29	91.1064	660.521
23½	74.2203	438.364	29½	91.4991	666.223
23½	74.6130	443.015	29½	91.8918	671.950
23½	75.0057	447.690	29½	92.2845	677.714
24	75.3984	452.390	29½	92.6772	683.504
24½	75.7911	457.115	29½	93.0699	689.320
24½	76.1838	461.864	29½	93.4626	695.163
24½	76.5765	466.638	29½	93.8553	701.032
24½	76.9692	471.438	30	94.2480	706.926
24½	77.3619	476.263	30½	94.6407	712.843
24½	77.7546	481.117	30½	95.0334	718.786
24½	78.1473	485.979	30½	95.4261	724.762
25	78.5400	490.875	30½	95.8188	730.768
25½	78.9327	495.796	30½	96.2115	736.819
25½	79.3254	500.742	30½	96.6042	742.905
25½	79.7181	505.712	30½	96.9969	748.995
25½	80.1108	510.706	31	97.3896	754.769
25½	80.5035	515.726	31½	97.7823	760.609
25½	80.8962	520.766	31½	98.1750	766.522
25½	81.2889	525.833	31½	98.5677	772.140
26	81.6816	530.929	31½	98.9604	777.813
26½	82.0743	536.048	31½	99.3531	783.510
26½	82.4670	541.190	31½	99.7458	789.242

CIRCUMFERENCES AND AREAS OF CIRCLES.					
Diam.	Circum.	Area.	Diam.	Circum.	Area.
31½	100.1285	797.979	37½	117.417	1,097.112
32	100.5312	804.250	37½	117.819	1,104.469
32½	100.9239	810.545	37½	118.223	1,111.844
32½	101.3166	816.865	37½	118.626	1,119.244
32½	101.7093	823.210	37½	119.028	1,126.669
32½	102.1020	829.579	38	119.431	1,134.118
32½	102.4947	835.972	38	119.773	1,141.591
32½	102.8874	842.391	38	120.166	1,149.089
32½	103.280	848.833	38	120.559	1,156.612
33	103.673	855.301	38	120.952	1,164.159
33½	104.065	861.792	38	121.344	1,171.731
33½	104.458	868.309	38	121.737	1,179.327
33½	104.851	874.850	38	122.130	1,186.948
33½	105.244	881.415	39	122.522	1,194.593
33½	105.636	888.005	39	122.915	1,202.263
33½	106.029	894.620	39	123.308	1,209.958
33½	106.422	901.259	39	123.706	1,217.677
34	106.814	907.922	39	124.093	1,225.420
34½	107.207	914.611	39	124.486	1,233.188
34½	107.600	921.323	39	124.879	1,240.981
34½	107.992	928.061	39	125.271	1,248.798
34½	108.385	934.822	40	125.664	1,256.640
34½	108.778	941.609	40	126.057	1,264.510
34½	109.171	948.420	40	126.449	1,272.400
34½	109.563	955.255	40	126.842	1,280.310
35	109.956	962.115	40	127.235	1,288.250
35½	110.349	969.000	40	127.627	1,296.220
35½	110.741	975.900	40	128.020	1,304.210
35½	111.134	982.822	40	128.412	1,312.220
35½	111.527	989.800	41	128.806	1,320.260
35½	111.919	996.783	41	129.193	1,328.330
35½	112.312	1,003.790	41	129.581	1,336.410
35½	112.705	1,010.822	41	129.964	1,344.520
36	113.098	1,017.878	41	130.376	1,352.660
36½	113.490	1,024.960	41	130.769	1,360.820
36½	113.883	1,032.065	41	131.162	1,369.000
36½	114.276	1,039.195	41	131.554	1,377.210
36½	114.668	1,046.349	42	131.947	1,385.450
36½	115.061	1,053.528	42	132.340	1,393.700
36½	115.454	1,060.732	42	132.732	1,401.980
36½	115.846	1,067.960	42	133.125	1,410.300
37	116.239	1,075.212	42	133.518	1,418.630
37½	116.632	1,082.490	42	133.911	1,426.990
37½	117.025	1,089.792	42	134.303	1,435.370

CIRCUMFERENCES AND AREAS OF CIRCLES.					
Diam.	Circum.	Area.	Diam.	Circum.	Area.
42½	134.090	1,443.770	46½	148.064	1,698.23
43	135.689	1,452.209	46¾	148.477	1,707.37
43½	135.481	1,468.569	46⅞	148.879	1,716.54
43¾	135.874	1,469.149	46⅝	147.263	1,725.73
43⅞					
43⅝	136.267	1,477.640	47	147.655	1,734.95
43⅜	136.660	1,486.170	47½	148.948	1,744.19
43⅓	137.052	1,494.730	47⅞	148.441	1,753.45
43¼	137.445	1,503.330	47⅝	148.833	1,762.74
43⅑					
43⅒	137.838	1,511.910	47⅓	149.226	1,772.06
44	138.239	1,520.530	47⅒	149.619	1,781.40
44½	138.623	1,529.199	47⅑	150.011	1,790.76
44¼	139.016	1,537.960	47⅒	150.404	1,800.15
44⅑					
44⅒	139.408	1,546.56	48	150.797	1,809.56
44⅓	139.801	1,555.29	48½	151.189	1,819.00
44⅒	140.194	1,564.04	48⅓	151.582	1,828.46
44¼	140.587	1,572.81	48⅒	151.975	1,837.95
44⅑					
44⅒	140.979	1,581.61	48¼	152.368	1,847.46
45	141.372	1,590.43	48⅓	152.760	1,856.99
45½	141.765	1,599.28	48⅒	153.153	1,866.55
45¼	142.157	1,608.16	48¼	153.546	1,876.14
45⅑					
45⅒	142.550	1,617.05	49	153.938	1,885.75
45⅓	142.943	1,625.97	49½	154.331	1,895.38
45⅒	143.335	1,634.92	49⅞	154.724	1,905.04
45¼	143.728	1,643.89	49⅝	155.116	1,914.72
45⅑					
45⅒	144.121	1,652.89	49¼	155.509	1,924.43
46	144.514	1,661.91	49⅓	155.902	1,934.16
46½	144.906	1,670.95	49⅒	156.295	1,943.91
46¼	145.299	1,680.02	49¼	156.687	1,953.69
46⅑					
46⅒	145.692	1,689.11	50	157.080	1,963.50



Faint, illegible text at the top of the page, possibly bleed-through from the reverse side.

**FUNDAMENTAL UNITS, MENSURATION,  
CONVERSION FACTORS AND  
METRIC UNITS**

## FUNDAMENTAL UNITS

The electrical units are derived from the following mechanical units:

The centimeter, the unit of length.

The gramme, the unit of mass.

The second, the unit of time.

The centimeter equals 0.3937 of an inch, or one thousand-millionth part of a quadrant of the earth.

The gramme is equal to 15.432 grains, the mass of a cubic centimeter of water at 4° C.

The second is the time of one swing of the pendulum, making 86,464.09 swings per day, or the 1-86400 part of a mean solar day.

## MENSURATION

Circumference of circle whose diameter is 1 =  $\pi$  = 3.14159265.

Circumference of any circle = diameter  $\times$   $\pi$ .

Area of any circle = (radius)<sup>2</sup>  $\times$   $\pi$ , or (diameter)<sup>2</sup>  $\times$  0.7854.

Surface of sphere = (diameter)<sup>2</sup>  $\times$   $\pi$ , or = circumference  $\times$  diameter.

Volume of sphere = (diameter)<sup>3</sup>  $\times$  0.5236, or = surface  $\times$   $\frac{1}{4}$  diameter.

Area of an ellipse = long diameter  $\times$  short diameter  $\times$  0.7854.

$\pi^2$  = 9.8696;  $\pi^{\frac{1}{2}}$  = 1.772454;  $\frac{\pi}{4}$  = 0.7854.

$\frac{1}{\pi}$  = 0.31831;  $\log \pi$  = 0.4971499.

Basis of natural log  $\epsilon$  = 2.7183,  $\log \epsilon$  = 0.43429.

Modulus of natural logarithm  $M = \frac{1}{\log \epsilon} = 2.3026$ .

1 lb. per sq. inch =  $\left\{ \begin{array}{l} 144 \text{ lb. per sq. foot.} \\ 51.7116 \text{ mm. of mercury.} \\ 2.30665 \text{ feet of water.} \\ 0.072 \text{ ton (short) per sq. foot.} \\ 0.0680415 \text{ atmosphere.} \end{array} \right.$

One mile = 320 rod = 1760 yards = 5280 feet = 63,360 inches.

One fathom = 6 feet; 1 knot = 6080 feet.

1728 cubic inches = 1 cubic foot.

231 cubic inches = 1 liquid gallon = 0.134 cubic foot.

1 pound avoirdupois = 7000 grains = 453.6 grammes.

The angle of which the arc is equal to the radius, a Radian = 57.2958°.

## PHYSICAL DATA

The equivalent of one B.t.u. of heat = 778 foot-pounds.

The equivalent of one calorie of heat = 426 kg.-m. = 3.968 B. t.u.

One cubic foot of water weighs 62.355 pounds at 62° F.

## CONVERSION FACTORS

## Sec. I

One cubic foot of air weighs 0.0807 pound at 32° F. and one atmosphere.

One cubic foot of hydrogen weighs 0.00557 pound.

One foot-pound =  $1.3562 \times 10^7$  ergs.

One horse-power hour =  $33,000 \times 60$  foot-pounds.

One horse-power = 33,000 foot-pounds per min. = 550 foot-pounds per second = 746 watts = 2545 B.t.u. per hour.

Acceleration of gravity (g) = 32.2 feet per second.  
= 980 mm. per second.

One atmosphere = 14.7 pounds per square inch.  
= 2116 pounds per square foot.  
= 760 mm. of mercury.

Velocity of sound at 0° cent. in dry air = 332.4 meters per sec.  
= 1091 feet per sec.

Velocity of light in vacuum = 299,853 km. per sec.  
= 186,325 miles per sec.

Specific heat of air at constant pressure = 0.237.

A column of water 2.3 feet high corresponds to a pressure of 1 pound per square inch.

Coefficient of expansion of gases =  $\frac{1}{273}$  = 0.00367.

Latent heat of water = 79.24.

Latent heat of steam = 535.9.

**CENTIGRADE DEGREES.** To convert into the corresponding one in Fahrenheit degrees, multiply by  $\frac{9}{5}$ , and add 32. To convert it into the one in Réaumur degrees multiply by  $\frac{4}{5}$ . To convert it into the one on the Absolute scale, add 273.

**FAHRENHEIT DEGREES.** To convert into the one in Centigrade degrees, subtract 32 and then multiply by  $\frac{5}{9}$ , being careful about the signs when the reading is below the melting point of ice. To convert it into the one in Réaumur degrees, subtract 32 and multiply by  $\frac{4}{9}$ . To convert it into the one on the Absolute scale, subtract 32, then multiply by  $\frac{5}{9}$ , and add 273; or multiply by 5, add 2297, and divide by 9.

## ELECTRICAL DATA

Watts { = unit of electric power = h. p.  $\times$  746.  
= current  $\times$  volts  $\times$  power factor.  
= foot pounds per sec.  $\div$  1.355.

Joules, W = work done = watts  $\times$  seconds.

1 kw. hour = { 3412 B.t.u.  
2,654,536 foot-pounds.  
3.53 pounds water evaporated at 212° F.  
22.8 pounds water raised from 62° to 212° F.  
0.235 pounds carbon oxidized at 100 per cent. eff.

## METRIC WEIGHTS AND MEASURES

### Linear

1 meter = 39.3704 inches = 3.281 feet = 1.094 yards.

Centimeter (1-100 meter) = 0.3937 inch.



## Sec. 1

## METRIC UNITS

1 millimeter (mm.) = 0.03937 inch = 39.37 mils.

1 inch = 25.3997 millimeters = 0.083 foot = 2.54 centimeters.

1 kilometer = 1,000 meters or 3,281 feet = 0.6213 mile.

For the purpose of memory, a meter may be considered as 3 feet  $3\frac{1}{8}$  inches.

### Surface Measures

Centare (1 square meter) = 1,550 square inches = 10.764 square feet.

Are (100 square meters) = 119.6 square yards.

1 square centimeter = 0.155 square inch = 197,300 circular mils.

1 square millimeter = 0.00155 square inch = 1973 circular mils.

1 square inch = 6.451 square centimeters = 0.0069 square foot.

1 square foot = 929.03 square centimeters = 0.0929 square meter.

### Weights

Milligram (1-1000 gram) = 0.0154 grain.

Centigram (1-100 gram) = 0.1543 grain.

Decigram (1-10 gram) = 1.5432 grains.

Gram = 15.432 grains.

Decagram (10 grams) = 0.3527 ounce.

Hectogram (100 grams) = 3.5274 ounces.

Kilogram (1,000 grams) = 2.2046 pounds.

Myriagram (10,000 grams) = 22.046 pounds.

Quintal (100,000 grams) = 220.46 pounds.

Millier or tonne—ton (1,000,000 grams) = 2,204.6 pounds.

### Volumes

Milliliter (1-1000 liter) = 0.061 cubic inch.

Centiliter (1-100 liter) = 0.6102 cubic inch.

Deciliter (1-10 liter) = 6.1023 cubic inches.

Liter = 1,000 cu. cm. = 61.023 cubic inches.

Hectoliter (100 liters) = 2.838 bushels.

Kiloliter (1,000 liters) = 1,308 cubic yards.

### Liquid Measures

Milliliter (1-1000) = 0.0338 fluid ounce.

Centiliter (1-100 liter) = 0.338 fluid ounce.

Deciliter (1-10 liter) = 0.845 gill.

Liter = 0.908 quart = 0.2642 gallon.

Decaliter (10 liters) = 2.6418 gallons.

Hectoliter (100 liters) = 26.418 gallons.

Kiloliter (1,000 liters) = 264.18 gallons.

**BIBLIOGRAPHY**

**Electrical Meterman's Handbook.**  
**American Institute of Electrical Engineers.**  
**Publications of Various Wire Manufacturers.**  
**Standard Handbook for Electrical Engineers.**  
**Foster's Electrical Engineer's Pocketbook.**



## **SECTION 2**

### **DISTRIBUTION AND TRANSMISSION LINE SUPPORTS**



**SECTION 2**  
**DISTRIBUTION AND TRANSMISSION**  
**LINE SUPPORTS**

---

**TABLE OF CONTENTS**

	ARTICLE
<b>Wood Poles</b>	
General.....	1
<b>Logging</b>	
White Cedar or Arbor Vitae.....	2
Chestnut.....	3
Western Red Cedar.....	4
Loblolly Pine Poles.....	5
Western Yellow Pine.....	6
Lodgepole Pine Poles.....	7
<b>Pole Defects.....</b>	<b>8</b>
Butt Rot.....	9
Heart Rot.....	10
Season Checks.....	11
Wind Shakes and Ring Shakes.....	12
Ring Rot.....	13
Cat Faces.....	14
<b>Pole Specifications</b>	
General.....	15
Specifications for Chestnut Poles.....	16
Specifications for Eastern White Cedar Poles.....	17
Specifications for Western White Cedar, Red Cedar, Western Cedar, Idaho Cedar.....	18
Specifications for Sawed Redwood Poles.....	19
Specification for Yellow Pine Poles.....	20
Specifications for Creosoted Yellow Pine Poles.....	21
<b>Concrete Poles</b>	
General.....	22
Steel Reinforcing.....	23
Concrete Mixture.....	24
Molding Pole.....	25
Hollow Concrete Poles.....	26
<b>Steel Poles and Towers.....</b>	<b>27</b>
Patented Steel Poles.....	28
Tubular Steel Poles.....	29
Structural Steel Poles and Towers.....	30
Flexible Towers.....	31
<b>Outdoor Substations.....</b>	<b>32</b>



## WOOD POLES

1. **General.** Wood poles comprise a large majority of the poles in use upon which are strung aerial conductors. Approximately 82 percent of the wood poles in use in this country are either cedar or chestnut. Cedar represents about 62 percent and chestnut about 20 percent of the total. The remaining 18 percent include poles manufactured from every specie of timber.\*

It is customary to purchase poles under specifications which usually provide for their dimensions, etc.; but, in general, the logging of the poles is entirely neglected. Inasmuch as it is the practice of a number of companies to purchase poles on the stump the following data on logging have been compiled, covering a few of the more important species, also the more important defects usually found in timber are described.

## LOGGING

2. **White Cedar or Arbor Vitae.** Northern white cedar or arbor vitae is a common swamp tree in the northeastern and lake states and in Canada. It is extensively used for poles as it grows to the required form and size, and also combines the desired strength, lightness and durability. Since the growth of this species is so slow, careful logging methods will not bring about reproduction that will benefit the present logger, the method of getting out white cedar poles is determined only by the mechanical and topographical problems involved.

The summer and winter are undoubtedly the best seasons in which to work in swamps and as woods labor is most available in winter this would seem to be the better of the two. Further because of the advantages of hauling on sleds, the late fall and winter offer the best conditions for cutting, skidding and hauling, and these operations are therefore usually carried on at that time. Stumps should not be cut low; and at least above the characteristic crook near the ground. Poles cut and peeled during the late fall and winter and skidded in a single layer well off the ground should be held until the first of May before shipping, thus insuring a decrease in freight weight more than equal to the expense of holding. Poles so held will also gain in strength and durability.

Green arbor vitae poles lose the larger portion of their moisture from the sapwood. This sapwood is very thin, consequently, the loss begins immediately after exposure to favorable seasoning influence, and a large percent of the moisture is lost during sixty days of fair weather. Spring and early summer offer the best conditions for maximum seasoning in the shortest time.

Checking during seasoning, if not serious, has no particular effect on the strength of the pole and is of little assistance in the absorption

---

\* U. S. Government Statistics.



of preservatives. The greatest checking occurs in the spring and summer cut poles. If arbor vitae poles are properly seasoned, the sapwood can be thoroughly impregnated with creosote in the open tank. Fall and winter cut poles, if properly skidded, should be in satisfactory condition for impregnation by the following June. If skidded several layers deep, as is the usual custom, they will probably have to be seasoned for a longer period.

**3. Chestnut.** The chestnut-bearing states are as follows: **New Hampshire, Vermont, Massachusetts, Connecticut, New York, New Jersey, Pennsylvania, Ohio, Maryland, Delaware, Virginia, West Virginia, Kentucky, Tennessee and North Carolina.**

The best chestnut poles are cut from trees grown in coves, on lower slopes, and in level country on deep, well-drained, loamy soil. It has been found that trees grown on high elevations have a larger



FIG. 20.—Butt Rot in Eastern White Cedar Pole. Right hand section was cut 5 feet from Butt. Middle section was cut 10 feet from Butt. Left hand section shows remainder of the pole.

taper than trees grown on lower levels. A considerable difference has been found where the elevation varies as little as 150 feet.

The exact relation between the inherent specific gravity of the wood and the strength of the pole is not definitely known. It is estimated, however, that the strength varies directly with the specific gravity.

Chestnut timber can be divided into two general classes—**seed-grown and sprout-grown.** The method of production of seed-grown trees is self-evident. Sprout-grown trees are trees that grow from the stumps of live timber which has been cut down. Such poles have a much more rapid growth; it is estimated that a tree of sufficient size from which to cut a 30 foot pole will mature when grown from a stump ten years sooner than a tree grown from seed. The average age of a sprout-grown tree from which a 30-ft. pole can be cut is forty years, and of those grown from seed to a similar size, fifty years.

In cutting chestnut-trees it is most important to consider the time at which the timber should be cut and the method of cutting. Undoubtedly the best season is the late fall and winter. This is due to the fact that most vigorous sprouts originate from winter-cut stumps. The cost of logging is least. The season is not conducive to the danger of an attack of fungi. The poles season persistently and have the advantage of a gradual rise in temperature as their moisture contents gradually decrease. The slow drying rate does not result in serious checking; hence the poles are stronger.

The spring and summer months are the most unfavorable months

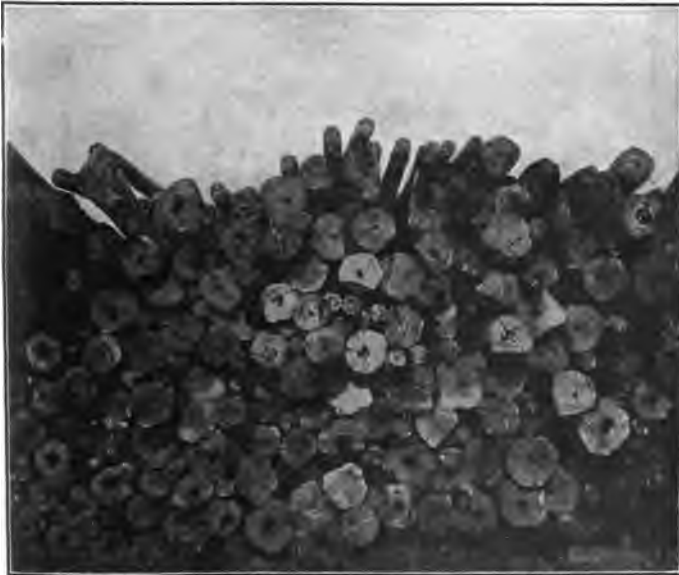

FIG. 21.—Frequency of Butt Rot in Eastern White Cedar Poles.

in which to cut timber, as it dries very rapidly, causing large season checks, which may seriously decrease the strength of the pole.

If trees are cut in summer, the stumps are practically killed, and few, if any, sprouts will originate from them. Summer cutting should, therefore, be discouraged. Moreover, trees cut at this season are subjected to decay and their strength may be materially affected thereby.

In cutting chestnut-trees, consideration should be given to cutting in such a manner that the stumps will sprout. This is accomplished

by cutting the tree as near the ground as possible and giving the cut a decided pitch, in order to avoid butt rot in the sprout-grown poles.

The height at which the pole is cut materially affects its taper. If the tree is cut low the basal swelling of the tree will be included in the pole, which, where the tree has been cut one (1) foot above the ground, increases the taper in circumference as much as five inches over its circumference if cut four (4) feet above the ground.

The practice of **dragging poles** over the ground for long distances should be **discouraged** because the outer layers of wood are sheared off and the strength of the poles is lessened. Further, a pole in this



FIG. 22.—Butt Rot in Eastern White Cedar Poles.

condition is more susceptible to decay because of the crevices caused thereby which will hold water and spores.

The tops of trees remaining after poles are cut should be utilized for cordwood, as this increases the gross value of the timber.

**4. Western Red Cedar.** The regions from which the largest production of western red cedar poles are secured are situated in the panhandle of the State of Idaho, or Puget Sound, in the vicinity of Bellingham and Everett, Washington and along the lower Columbia River. Some poles are logged in the Grays Harbor region of the State of Washington.

The northern portion of the State of Idaho produces more poles

than any similar region in the United States. West Coast poles are logged and marketed on Puget Sound. Poles obtained from the lower Columbia River are heavier butted and weigh more than those from either of the above mentioned regions. The taper and other properties of Columbia River poles compare favorably with those secured from other regions, but Columbia River poles are generally free from butt rot, which is not so true of Idaho cedar poles.

The logging and piling of cedar poles is generally carried on in advance of the logging of saw timber, the pole company taking the small timber before the fellers of saw timber advance in the woods.



Fig. 23.—Hollow Knot indicating Heart Rot in Eastern White Cedar Pole.

This is an important item of conservation, since in ordinary logging operations where pole timber is not removed it is destroyed by breakage in felling the larger trees. Poles are generally removed from the woods by horse team, usually to storage yards or to the logging railroad of the logging company, over which they are transported to storage yards or connecting railroad transportation.

In Idaho and on Puget Sound many poles are cut by ranchers in the clearing of land and are finally marketed through pole companies.

Poles are always peeled on the ground immediately after felling

or in the pole yard close by. As a rule the pole cutter works alone, felling the timber, slashing the branches and peeling.

Pole dealers contend that winter cut poles are more durable and are stronger than summer cut poles because the sap is down in the winter, the moisture content is less and the poles check less in drying. However, when the sap is down, poles are harder to peel. Users prefer winter cut poles and generally order such. The pole cutting season in Idaho extends from May 1st to December 1st and often throughout the year. On Puget Sound poles are cut at any time during the year, preferably, however, during the winter season in

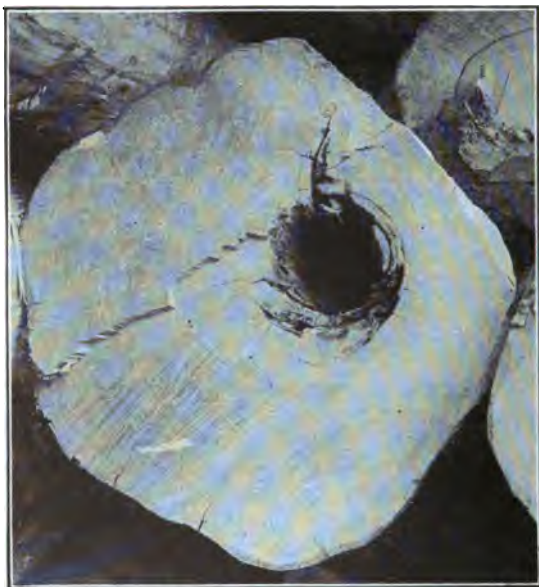

FIG. 24.—Butt Rot in Chestnut Pole.

order to meet the demands of the trade for winter cut poles. The season of cutting affects the rate of drying and the resulting checking, but otherwise offers no convenience to the cutter or dealer.

On Puget Sound it is customary to store poles for water shipments in fresh water booms in the rivers a short distance from the Sound. This fresh water storage insures against the attack of teredo and other salt water borers. In the Inland Empire the poles, after being peeled, are yarded and stored on the ground for seasoning or they are boomed in the Inland lakes or rivers. Ground storage is often

practiced in the Puget Sound region, if, as is the exception, the poles are for rail distribution.

Poles for cargo shipments on Puget Sound are gathered from the fresh water booms and are built into cribs in the salt water. Cribs are built in tiers and contain from 200 to 300 poles sorted for length and top diameter. Each tier is laid at right angles to the one below and the crib generally contains five or six tiers of poles. In loading for water shipments, these cribs are towed to the side of the vessel and the poles are loaded direct.

Poles cannot be stored in the salt water on Puget Sound for a long period because of the attack of the teredo. During the months of August and September thirty days' storage will show the beginning of teredo attack, while during the winter and spring seasons they will not be active for from four to six months. It is also claimed that the teredo is much more active on mud flats than on gravel bottoms. Therefore, when storage grounds are in salt water, the

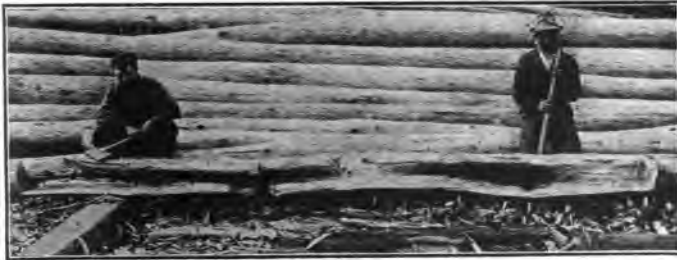

FIG. 25.—Heart Rot in Chestnut Pole.

grounds should be carefully selected and the poles loaded as soon as possible after storage.

It is noticeable that specifications for cedar poles generally provide that the poles be cut from live, growing cedar timber. This excludes the use of insect or fire-killed pole timber. If fire-killed poles are cut before decay or insect attack begins, they are not necessarily inferior unless the killing fire injured the wood of the tree in a visible manner. Fire-killed poles may generally be considered more durable and more economical to handle as they season before cutting. Furthermore, in cases where the bark has fallen, some of the food substances in the sapwood which nourish destructive fungous agencies are leached out by rains, and decay is retarded. Unless large cracks or checks develop, it is doubtful if the fire-killed timber is materially weaker than green cut timber. Many fire-killed or dead cedar poles are accepted under specifications requiring green cut poles, the inspectors being unable to distinguish them. Such poles have been used in the same line with green cut poles and have given equal satisfaction. There is no well defined reason for

excluding dead poles from specifications, provided they are sound and show no detrimental defects, such as insect workings, decay of serious checking. Checking, in fact, is liable to be more severe in green logged, air seasoned poles than in fire-killed poles, provided the bark of the fire-killed poles was not directly destroyed by the killing fire.

**5. Loblolly Pine Poles.** Loblolly pine is a probable important future source of poles because of the depletion of the northern white cedar stand and because of the destruction of chestnut forests by the bark disease. Generally speaking loblolly pine is not as good a pole timber as northern white cedar or chestnut, as it is likely to be



FIG. 26.—Checks and Butt Rot in Eastern White Cedar Pole.

very knotty and trees of pole form are not so common in pine stands as they are in chestnut and cedar stands.

Trees suitable for poles will be found more often in medium open old field stands. The more open stands will have trees that are very knotty while dense stands are likely to produce trees comparatively small at the butt and of little taper. It is advisable to cut loblolly pine poles in the later fall or winter in order to allow as much seasoning as possible before spring, for the reason that spring cut poles are very liable to decay during seasoning owing to the unevaporated water they contain. Loblolly pine poles should be given a preservative treatment before using and before such treatment

they should be placed on high skids with space between all poles, and seasoned for several months or else artificially seasoned.

**6. Western Yellow Pine.** In certain parts of the states of California, Nevada, Utah, Wyoming, Colorado, Arizona and New Mexico, it may be advisable for pole using companies to use a local timber rather than bring in western red cedar poles by rail. Throughout this region there is a great deal of western yellow pine. Such timber will furnish poles which will give good service if treated. The following statements are conclusions from an investigation in California. Poles of western yellow pine should be cut from hill-grown timber rather than from valley-grown timber.



FIG. 27.—Ring Shakes in Chestnut Pole.

Hill-grown timber grows under dryer conditions and on poorer soil; hence it grows much more slowly. It grows remarkably straight and free from limbs. It has a uniform taper, which is less pronounced and better adapted to poles than valley grown timber. This particular kind of timber is finer grained, stronger and contains much more heartwood.

Valley Grown Timber is more liable to knottiness, it is badly shaped, rarely shows any heartwood and usually grows so rapidly that the annular rings do not hang together. Valley grown timber also has a very coarse grain and if grown in the open, has a large taper and many small limbs. The bole in such timber forms a spool-like shape between each tree's growth or whorl or limbs,



## Sec. 2

## WOOD POLES

making a knotty and badly appearing pole. The butt is apt to be oversize and of irregular shape. Where such timber grows closely together it often has many limbs well toward the ground but these limbs are smaller and there are no spool-like depressions between the whorls. Such timber makes good poles.



FIG. 28.—Butt Rot and Ring Shakes in Eastern White Cedar Pole.



FIG. 29.—Ring Rot in Chestnut Pole.

Western yellow pine has a short life below ground. As a pole timber it will serve but two or three years untreated and if set green will show decided decay in one year. Otherwise, it is satisfactory. The decay-resisting power can be controlled by the use of preservatives which the timber takes successfully. All yellow pine poles should be treated with a preservative before use.

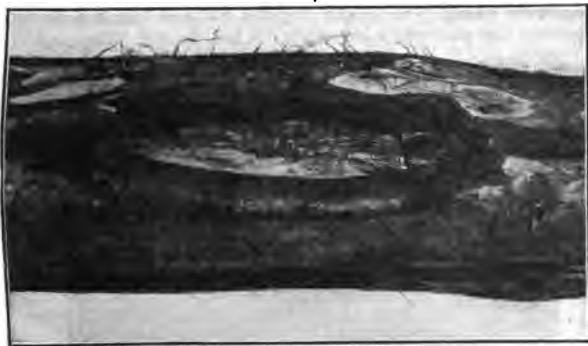

FIG. 30B.—Cat Face in Chestnut Pole.



FIG. 30A.—Cat Face in Chestnut Tree.

The poles should be well seasoned before treatment and are best treated during the second summer after cutting.

The poles should not be lumbered during the summer for the reason that case hardening, due to rapid drying, causes summercut poles to resist the entrance of preservatives to a marked degree. Poles may be cut at any other season but preferable during the

autumn, after September, as the fall-cut poles absorb the preservative far more readily than poles cut during any other season.

**7. Lodgepole Pine Poles.** In the **Rocky Mountain and Coast Ranges** there are at present abundant stands of lodgepole pine which after treatment make very satisfactory poles. It is not naturally durable in contact with the ground, but it takes treatment readily and even with the additional cost of treatment the pine pole is comparatively cheap. In many regions outside the region where cedar grows, the pine may be made to last longer than untreated cedar.

Poles should be cut from fairly dense stands in order to avoid the **knottiness** in open grown trees and the **small slender poles**



FIG. 31.—Ant Eaten Butt in Eastern White Cedar Pole.

grown in very thick stands. As in the case of other species, lodgepole pine poles should be thoroughly seasoned before treatment. Forest fires have killed many stands of lodgepole pine and on many such areas the timber remains entirely sound for many years after the fire. Such timber is thoroughly seasoned and therefore ready for treatment as soon as cut. When both sound dead timber and live timber are available for poles which are to be treated, the sound dead timber is usually preferable as it is already seasoned. The prejudice in many regions against the use of dead timber is based on the mistaken assumption that there is some inherent difference in wood that has been seasoned on the stump and wood that has been cut when green.

**8. Pole Defects.** The natural defects, some of which, are found in all kinds of timber make theoretical calculations of strength very uncertain. It is of utmost importance that all poles be subjected to a most careful inspection, in order that a reasonably uniform product will be secured. The defects which may occur in all kinds of timber are more or less similar. The principal ones are as follows:

- |                                    |           |
|------------------------------------|-----------|
| (a) Butt Rot                       | (Art. 9)  |
| (b) Heart Rot                      | (Art. 10) |
| (c) Season Checks                  | (Art. 11) |
| (d) Wind shakes, Ring shakes, etc. | (Art. 12) |
| (e) Ring Rot                       | (Art. 13) |
| (f) Cat Faces                      | (Art. 14) |

**9. Butt Rot** (Figs. 20, 21, 22 and 24) is more prevalent in some species of timber than in others. When appearing in chestnut poles it is usually found in **sprout grown** trees and is generally the



FIG. 32.—Ant Eaten Butt in Eastern White Cedar Pole.

result of careless cutting of the original tree. The rot should be confined to a small proportional part of the cross-section of the butt. It should not extend into the pole a very great distance and never to above what will be the ground line.

**10. Heart Rot** (Figs. 23 and 25) is usually evidenced by small defective knots which show rot. It is extremely important that such knots be carefully examined. Fig. 25 shows an apparently perfectly sound chestnut pole. A few small knots about 0.5 inches in diameter indicated evidence of heart rot. The pole was cut into and decided heart rot was found existing for about 15 feet of the pole's length.

**11. Season Checks** (Fig. 26) are due mostly to the rate at which the pole is seasoned. The more rapid the seasoning, the more

## Sec. 2

## WOOD POLES

extensive the checks. In general, they may be said to decrease the strength of the pole. The greater their number, or the larger their size, the weaker the pole.

**12. Wind Shakes and Ring Shakes.** (Figs. 27 and 28.) Wind shakes and ring shakes are caused by wind strains in the standing tree or by careless felling. Such defects may seriously damage the pole. Defects which are incipient in green poles sometimes extend until they form a split anywhere from 1 to 9 feet long. The extent of such defects should be carefully examined, in order that the strength of accepted poles will not be materially reduced.

**13. Ring Rot.** (Fig. 29.) takes the form of a ring and is usually in evidence at the butt of the pole. When such rot exists, it should



FIG. 33.—Ant Esten Butt in Chestnut Pole.

not be extensive in character and should not extend into the pole for too great a distance.

**14. Cat Faces** (Figs. 30A and B) are the result of an injury to a tree over which the bark never heals. The wood at this point dries out and is not covered, except at the edges of a wound, by new wood or bark and therefore becomes dead wood. Sometimes there is also a swelling at this point. It is exposed to fungus, insect attack, and weathering, and therefore, after a pole has been cut and peeled, the

cat face shows as a weathered place, which it may not be possible to eliminate by shaving. However, if no decay has started in the cat face, the pole should not be rejected. If any decay, which has started, can be shaved off and down into sound wood without materially decreasing the pole diameter at this point, the pole should not be rejected. A pole that shows bright sap just after shaving with one or more cat faces, will, after it has seasoned a year or more, present practically the same appearance all over.

#### POLE SPECIFICATIONS:

**15. General.** The preparation of specifications covering all kinds of timber would be extremely lengthy. Therefore, detail specifications are given for the more generally used timbers only.

The selection of the proper kind of timber, from which poles should be manufactured, is governed entirely by the locality in which they are to be used. Any available timber may be used provided it develops sufficient **mechanical strength**. The theoretical strength of a pole is dependent on the diameter of the butt, the modulus of rupture of the timber, and the taper. The natural defects found in all kinds of timber makes it necessary that they be subjected to very careful inspection, in order that incipient rot, bad knots, etc. do not decrease their strength to a dangerous degree.

The theoretical calculation of the strength of a wood pole (Sec. 8, Art. 18) develops the following important facts.

A pole will break where its diameter is 1.5 times the diameter at which the load is applied. (The critical diameter.)

When the taper of a pole, with a given top diameter, is uniform and of such a value that the ground line diameter is greater than the critical diameter, the strength of the pole is constant and independent of its height; when the height of such a pole is reduced until its diameter at the ground line is less than the critical diameter, the strength will vary, depending upon its height and its diameter at the ground line.

When the diameter at the ground line is greater than the critical diameter, a certain decrease in ground line diameter, due to rot, may occur without decreasing the strength of the pole; this amount of decrease is dependent only on the taper of the pole.

From the above, it follows that pole specifications should be such that the greatest possible taper will be secured, and if the kind of timber is such that small tapers are natural the butt diameter should be the controlling factor. Where larger tapers are natural the butt and top diameters must be considered.

#### 16. SPECIFICATIONS FOR CHESTNUT POLES.\*

To determine the character of poles to be used, pole lines may be divided into the three following classes:

Class "A": for heavy transmission lines or heavy distribution lines.

---

\* National Electric Light Association Specification.

**Sec. 2**

**WOOD POLES**

Class "B": for light transmission lines or ordinary distribution lines.

Class "C": for very light distribution lines or light secondary lines.

The purchasing company is to have the right to make such inspections of the poles as it may desire. The inspector of the purchasing company shall have the power to reject any pole which is defective in any respect. Inspection, however, shall not relieve the manufacturer from furnishing perfect poles.

Any imperfect poles which may be discovered before their final acceptance shall be replaced immediately upon the requirement of the purchasing company, notwithstanding that the defects may have been overlooked by the inspector. If the requirements of these specifications are not fulfilled when the poles are offered for final acceptance, not only shall the purchasing company have the right to reject the poles, but the expense of inspection of such defective poles shall be borne by the manufacturer.

All poles shall be subject to inspection by the purchasing company, either in the woods, where the trees are felled, or at any point of shipment or destination. Any pole failing to meet all the requirements of these specifications may be rejected.

All poles shall be of the best quality live white chestnut, squared at both ends, reasonably straight, well proportioned from butt to top, peeled and with knots trimmed close.

The dimensions of poles shall be according to the following table,

DIMENSIONS OF POLES IN INCHES.						
Length of Poles.	CLASSES.					
	A		B		C	
	Top.	6' from Butt.	Top.	6' from Butt.	Top.	6' from Butt.
25					20	30
30	24	40	22	36	20	33
35	24	43	22	40	20	36
40	24	45	22	43	20	40
45	24	48	22	47	20	43
50	24	51	22	50	20	46
55	22	54	22	53	20	49
60	22	57	22	56		
65	22	60	22	59		
70	22	63	22	62		
75	22	66	22	65		
80	22	70	22	69		
85	22	73	22	72		
90	22	76	22	75		

## WOOD POLES

Sec. 2

the "Top" measurements being the circumference at the top of the pole, and the "Butt" measurement being the circumference six feet (6' 0") from the butt.

### 17. SPECIFICATIONS FOR EASTERN WHITE CEDAR POLES.\*

The material desired under these specifications consists of poles of the best quality of either seasoned or live green cedar of the dimensions hereinafter specified. Seasoned poles shall have preference over green poles provided they have not been held for seasoning long enough to have developed any of the timber defects hereinafter referred to. All poles shall be reasonably straight, well proportioned from butt to top, shall have both ends squared, the bark peeled and all knots and limbs closely trimmed.

#### Dimensions

The dimensions of the poles shall be in accordance with the following table, the "top" measurement being the circumference at the top of the pole and the "butt" measurement the circumference six (6) feet from the butt.

<b>MINIMUM DIMENSIONS OF POLES IN INCHES (CIRCUMFERENCE)</b>						
Length of Poles. (Feet.)	CLASSES.					
	A		B		C	
	Top.	6' from Butt.	Top.	6' from Butt.	Top.	6' from Butt.
25			22	32	18	30
30	24	40	22	36	18	33
35	24	43	22	38	18	36
40	24	47	22	43	18	40
45	24	50	22	47	18	43
50	24	53	22	50	18	46
55	24	56	22	53	18	49
60	24	59	22	56		

When the dimension at the butt is not given the poles shall be reasonably well proportioned throughout their entire length.

The dimension requirement at the six (6) foot mark shall be rigidly followed in all cases. Class, A, B, and C Poles may have top cir-

\* National Electric Light Association Specification.



## Sec. 2

## WOOD POLES

circumference not more than one half ( $\frac{1}{2}$ ) inch less than those shown in the preceding table. No pole shall be over six (6) inches longer or three (3) inches shorter than the length for which it is accepted; if any pole be more than six inches longer than is required it shall be cut back.

### Quality of Timber

**Dead Poles.** The wood of a dead pole is grayish in color. The presence of a black line on the edge of the sapwood (as seen on the butt) also shows that a pole is dead. No dead poles, and no poles having dead streaks covering more than one quarter of their surface shall be accepted under these specifications. Poles having dead streaks covering less than one quarter of their surface shall have a circumference greater than otherwise required. The increase in the circumference shall be sufficient to afford a cross-sectional area of sound wood equivalent to that of sound poles of the same class.

**Fire Killed or River Poles.** No dark red or copper colored poles, which when scraped do not show good live timber shall be accepted under these specifications.

**Twisted, Checked or Cracked Poles.** No poles having more than one complete twist for every twenty (20) feet in length, no cracked poles containing large season checks shall be accepted under these specifications.

**"Cat Faces."** No poles having "cat Faces," unless they are small and perfectly sound and the poles have an increased diameter at the "cat face," and no poles having "cat faces" near the six (6) foot mark or within ten (10) feet of their tops, shall be accepted under these specifications.

**Shaved Poles.** No shaved poles shall be accepted under these specifications.

**Miscellaneous Defects.** No poles containing sap rot, evidence of internal rot as disclosed by a careful examination of all black knots, hollow knots, woodpecker holes, or plugged holes; and no poles showing evidences of having been eaten by ants, worms or grubs shall be accepted under these specifications, except that poles containing worm or grub marks below the six (6) foot mark will be accepted.

**Crooked Poles.** No poles having a short crook or bend, a crook or bend in two planes or a reverse curve shall be accepted under these specifications. The amount of sweep, measured between the six foot mark and the top of the pole, that may be present in poles acceptable under these specifications, is shown in the following table:

35 foot poles shall not have a sweep over	10 $\frac{1}{2}$ inches.
40 foot poles shall not have a sweep over	12 inches.
45 foot poles shall not have a sweep over	9 inches.
50 foot poles shall not have a sweep over	10 inches.
55 foot poles shall not have a sweep over	11 inches.
60 foot poles shall not have a sweep over	12 inches.

## WOOD POLES

Sec. 2

**Defective Tops.** Poles having tops of the required dimensions must have sound tops. Poles having tops one (1) inch or more above the requirements in circumference may have one (1) pipe rot not more than one-half ( $\frac{1}{2}$ ) inch in diameter. Poles with double tops or double hearts shall be free from rot where the two parts or hearts join.

**Defective Butts.** No poles containing ring rot (rot in the form of a complete or partial ring) shall be accepted under these specifications.

Poles having hollow hearts may be accepted under the conditions shown in the following table:

Average Diameter of Rot.	Add to Butt Requirements		
	of 25 and 30 foot Poles.	of 35, 40 and 45 foot Poles.	of 50, 55, 60 and 65 foot Poles.
2 inches	Nothing	Nothing	Nothing
3 inches	1 inch	Nothing	Nothing
4 inches	2 inches	Nothing	Nothing
5 inches	3 inches	1 inch	Nothing
6 inches	4 inches	2 inches	1 inch
7 inches	Reject	4 inches	2 inches
8 inches	Reject	6 inches	3 inches
9 inches	Reject	Reject	4 inches
10 inches	Reject	Reject	5 inches
11 inches	Reject	Reject	7 inches
12 inches	Reject	Reject	9 inches
13 inches	Reject	Reject	Reject

Scattered rot, unless it is near the outside of the pole may be estimated as being the same as heart rot of equal area.

**"Wind Shakes."** Poles with cup shakes (Checks in the form of rings) which also have heart or star checks may be considered as equal to poles having hollow hearts of the average diameter of the cup shakes.

**Inspection.** All poles shall be subject to inspection by the purchaser's representative, either in the woods where the trees are felled, or at any point of shipment, or destination. Each pole thus inspected shall be marked according to its length and class with a marking hammer, by the purchaser's representative. All poles failing to meet these specifications shall be rejected.

### 18. SPECIFICATIONS FOR WESTERN WHITE CEDAR, RED CEDAR, WESTERN CEDAR, IDAHO CEDAR.\*

#### General.

The material desired under these specifications consists of poles and guy stubs of the best quality of either seasoned or live green

\* American Telephone & Telegraph Co. Specification.

Sec. 2

**WOOD POLES**

cedar of the dimensions hereinafter specified. The poles covered by these specifications are of Western White Cedar, otherwise known as red cedar, western cedar, or Idaho cedar. Seasoned poles shall have preference over green poles provided they have not been held for seasoning long enough to have developed any of the timber defects hereinafter referred to. All poles shall be reasonably straight, well proportioned from butt to top, shall have both ends squared, sound tops, the bark peeled, and all knots and limbs closely trimmed.

**Dimensions.**

The dimensions of the poles shall be in accordance with the following table, the "top" measurement being the circumference at the top of the pole and the "butt" measurement, the circumference six (6) feet from the butt. The dimensions given are the minimum allowable circumferences at the point specified for measurement and are not intended to preclude the acceptance of poles of larger dimensions.

When the dimension at the butt is not given, the poles shall be reasonably well proportioned throughout their entire length. No pole shall be over six (6) inches longer or three (3) inches shorter than the length for which it is accepted. If any pole is more than six (6) inches longer than is required it shall be cut back.

<b>MINIMUM DIMENSIONS OF POLES IN INCHES.</b>			
Length of Poles. (Feet.)	CLASSES.		
	A	B	C
	(Minimum Top Circumference 28) 6 feet from Butt	(Minimum Top Circumference 25) 6 feet from Butt	(Minimum Top Circumference 22) 6 feet from Butt
20	30	28	26
22	32	30	27
25	34	31	28
30	37	34	30
35	40	36	32
40	43	38	34
45	45	40	36
50	47	42	38
55	49	44	40
60	52	46	41
65	54	48	43

**Quality of Timber**

**Dead Poles.** No dead poles and no poles having dead streaks covering more than one quarter of their surface shall be accepted under these specifications. Poles having dead streaks covering less than one-quarter of their surface shall have a circumference greater than otherwise required. The increase in the circumference shall be sufficient to afford a cross sectional area of sound wood equivalent to that of sound poles of the same class.

**Twisted, Checked or Cracked Poles.** No poles having more than one complete twist for every twenty (20) feet in length, no cracked poles, and no poles containing large season checks, shall be accepted under these specifications.

**Crooked Poles.** No poles having a short crook or bend, a crook or bend in two planes, or a reverse crook or bend shall be accepted under these specifications. The amount of sweep measured between the six (6) foot mark and the top of the pole, shall not exceed one (1) inch to every six (6) feet in length.

**"Cat Faces."** No poles having "cat faces" unless they are small and perfectly sound, and the poles have an increased diameter at the "cat face," and no poles having "cat faces" near the six (6) foot mark, or within ten (10) feet of their tops shall be accepted under these specifications.

**Shaved Poles.** No shaved poles shall be accepted under these specifications.

**Wind Shakes.** No poles shall have cup shakes (checks in the form of rings) containing heart or star shakes which enclose more than ten (10) percent of the area of the butt.

**Butt Rot.** No poles shall have butt rot covering in excess of ten (10) percent of the total area of the butt. The butt rot, if present, must be located close to the center in order that the pole may be accepted.

**Knots.** Large knots, if sound and trimmed close shall not be considered a defect. No poles shall contain hollow or rotten knots.

**Miscellaneous Defects.** No poles containing sap rot, woodpecker holes or plugged holes, and no poles showing evidences of having been eaten by worms, ants, or grubs shall be accepted under these specifications.

**19. SPECIFICATIONS FOR SAWED REDWOOD POLES\***

**General.** The material desired under these specifications consists of poles of redwood (*Sequois Sempervirens*) sawed to shape as hereinafter set forth.

**Quality of Timber and Workmanship.** All poles shall be of sound Number One Common Redwood; they should be reasonably straight and well sawn.

---

\* American Telegraph & Telephone Co. Specification.

## Sec. 2

## WOOD POLES

**Dimensions.** The dimensions of the poles shall be in accordance with the following table:

Length in Feet.	A		B	
	Top.	Butt.	Top.	Butt.
24	6'' x 6''	6'' x 6''	4'' x 6''	4'' x 6''
25	7'' x 7''	10'' x 10''	6'' x 6''	9'' x 9''
30	7'' x 7''	11'' x 11''	6'' x 6''	10'' x 10''
35	7'' x 7''	12'' x 12''	6'' x 6''	11'' x 11''
40	7'' x 7''	13'' x 13''	6'' x 6''	12'' x 12''
45	7'' x 7''	14'' x 14''	6'' x 6''	13'' x 13''
50	7'' x 7''	15½'' x 15½''	6'' x 6''	14'' x 14''

The sectional dimensions of the sawn poles shall not be more than one-quarter ( $\frac{1}{4}$ ) of an inch under or three quarters ( $\frac{3}{4}$ ) of an inch over the dimensions specified in the above table. No pole shall be more than three inches longer or shorter than the lengths required in the above table.

**Sapwood.** No pole shall have sapwood covering more than four (4) percent of the area of all the surfaces. No pole shall have sapwood for a distance of more than eight (8) feet from the top. No sapwood shall be deeper than one (1) inch at any point.

**Plugged Holes.** No poles shall contain plugged holes.

**Cracked Poles.** No pole shall contain cracks transverse to the length of the pole.

**Checked Poles.** No pole shall contain large season checks.

**Wind Shakes.** No pole shall contain wind shakes including in excess of ten (10) percent of the area of the butt.

**Knots.** No pole shall contain loose, hollow, or rotten knots, black or red knots shall be carefully examined for internal rot.

In 4'' x 6'' poles sound knots with a diameter smaller than one (1) inch may be present in any number. No 4'' x 6'' pole shall be accepted which contains more than one sound knot in each five superficial feet having a diameter of one (1) inch or more, or which contains any knots with a diameter greater than one and one half ( $1\frac{1}{2}$ ) inch.

In all other sizes of poles covered by these specifications sound knots with a diameter smaller than one and one half ( $1\frac{1}{2}$ ) inches may be present in any number. No pole shall be accepted which contains more than one sound knot in each five superficial feet having a diameter of one and one half ( $1\frac{1}{2}$ ) inches or more, or which contains any knots of a diameter greater than two and one-half ( $2\frac{1}{2}$ ) inches.

**NOTE:** Where diameters are specified in connection with knots the knot shall be rated on the basis of its average diameter.

## 20. SPECIFICATION FOR YELLOW PINE POLES \*

**Quality of Timber.** All poles shall be cut from the best quality of live, straight grained, unbled, long leaf yellow pine. The butt end shall be squared and the top end pointed to an angle of 45 degrees. The poles shall be sawed octagonal in shape and shall be dressed, with the heart running parallel to the line of the pole. The timber shall be free of decayed or loose knots or clusters of small knots.

**Classification and Dimensions.** Poles shall be classified according to their butt dimensions into two classes, to be known as Class "A" poles and Class "B" poles, with dimensions for the respective classes as specified in the following table. Where "top" measurement is specified it shall be the diameter at the top of the pole and where "butt" measurement is specified it shall be at the diameter of the butt end of the pole.

**Inspection and Rejection.** All poles shall be subject to inspection by the purchaser's representative, either in the woods where the trees are felled, or at any point of shipment, or destination. Each pole thus inspected shall be marked according to its length and class with a marking hammer, by the purchaser's representative. All poles failing to meet these specifications shall be rejected.

DIMENSIONS OF POLES IN INCHES (DIAMETER)				
Length of Poles. (Feet.)	CLASSES.			
	A		B	
	Top.	Butt End.	Top.	Butt End.
30	8	11	7	10
35	8	12	7	11
40	8	13	7	12
45	8	14	7	12
50	8	15	7	13
55	8	16	7	14
60	8	17		
65	8	18		

\* National Electric Light Association Specification.

Sec. 2

WOOD POLES

21. SPECIFICATIONS FOR CREOSOTED YELLOW PINE POLES.\*

These specifications are for Class A, B and C poles of Southern Yellow Pine treated with Dead Oil of Coal Tar.

**Quality of Poles.** All poles shall be sound southern yellow pine (longleaf, shortleaf, or loblolly yellow pine,) squared at the butt, reasonably straight, well proportioned from butt to top, peeled and with knots trimmed close. All poles shall be free from large or decayed knots. All poles shall be cut from live timber.

It is desired that all poles be well air seasoned before treatment and such poles shall be treated in accordance with the requirements for treating seasoned timber contained in the "Specifications for Creosoting Timber" referred to in Section 9. The poles shall not be held for seasoning, however, up to the point where local experience shows that sap-wood decay would begin. Unseasoned poles shall be treated in accordance with the requirements for treating unseasoned timber contained in the above mentioned specifications.

All poles shall be sufficiently free from adhering "inner bark" before treatment to permit the penetration of the oil. If the "inner bark" is not satisfactorily removed when the pole is peeled, the pole shall either be shaved, or be allowed to season until the "inner bark" cracks and tends to peel off of the surface of the pole.

**Dimensions.** The dimensions of the poles shall not be less than those given in the following table:

DIMENSIONS OF POLES IN INCHES (CIRCUMFERENCE).			
Length of Poles (Feet.)	Class A	Class B	Class C
	6' from Butt.	6' from Butt.	6' from Butt.
25	33	30	28½
30	35	32	30½
35	38	34	32
40	40	36	34
45	42½	38	36
50	44½	40	38
55	47	42½	40
60	49	44½	42
65	51	47	44
70	53	49	46
75	55	51	
80	57		

No class A poles having a top circumference of less than 22 inches will be accepted.

\* American Telephone & Telegraph Co. Specification.

No class B poles having a top circumference of less than 20 inches will be accepted.

No class C poles having a top circumference of less than 18 inches will be accepted.

**Framing of Poles.** Before the poles are subjected to the creosoting process they shall be framed, unless otherwise ordered, in the following manner and as shown in drawing No. —.

The tops of all poles shall be roofed at an angle of ninety (90) degrees.

All class A poles shall have eight (8) gains, all class B poles shall have four (4) gains and all class C poles shall have two (2) gains.

The gains shall be located on the side of the pole with the greatest curvature, and on the convex side of the curve. The faces of all gains shall be parallel. Each gain shall be four and one-half ( $4\frac{1}{2}$ ) inches wide and one-half ( $\frac{1}{2}$ ) inch deep, spaced twenty-four (24) inches on centers. The center of the top gain shall be twelve (12) inches from the apex of the gable. A twenty-one thirty-second ( $\frac{21}{32}$ ) inch hole shall be bored through the pole at the center of each gain perpendicular to the plane of the gain.

**Inspection.** The quantity of dead oil of coal tar forced into the poles shall be determined by tank measurements, and by observing the depth of penetration of the oil into the pole. In the case of poles having a growth of sapwood not less than one and one-half ( $1\frac{1}{2}$ ) inches in thickness, the depth of penetration shall be not less than one and one-half ( $1\frac{1}{2}$ ) inches. In the case of poles having a growth of sapwood less than one and one-half ( $1\frac{1}{2}$ ) inches in thickness, the dead oil or coal tar shall penetrate through the sapwood and into the heartwood.

Depth of penetration shall be determined by boring the pole with a one (1) inch auger. The right is reserved to bore, for this purpose, two holes at random about the circumference, one hole (5) five feet from the butt and one hole ten (10) feet from the top. After inspection each bore hole shall be first filled with hot dead oil of coal tar, and then with a close fitting creosoted wooden plug.

The rejection of any pole on the score of insufficient penetration shall not preclude its being retreated and again offered for inspection.

### REINFORCED CONCRETE POLES.

**22. General.** Reinforced Concrete poles are divided into two general classes, the solid and the hollow type; the latter type serves a two fold purpose of decreasing the weight of the pole and providing a means for making connections through the pole from aerial lines to underground cable.

The solid type has been used to the greatest extent in the United States, the probable reason being that this type is more easily made.

In the casting of concrete poles horizontal forms are generally employed, although in several instances poles have been cast in position in vertical forms.

The forms for casting poles (the types of which, are illustrated in



Figs. 34 and 35), generally consist of tapered troughs of wood or steel of the desired form, so constructed that the sides can be removed after the concrete has set.

The general requirements, of a form for concrete poles, are the same as for any other kind of concrete work where the forms are to be used repeatedly.

The material should be such that there will be no **warping** and the construction should be such that there will be no **leakage** when using sloppy concrete, no **bulging** of the sides when filled, and that it will be sufficiently rigid to retain its shape with ordinary handling.

In general, a square, octagonal, circular or other cross-section may be used, but it is desirable as a matter of appearance, since sharp corners are difficult to make and subject to accident, that all such corners be **chamfered** or **rounded**. The minimum diameter, or width, at the top may be made 5 or 6 inches for small poles, and increased as required for the strength and appearance of long poles, or poles carrying a heavy line. In any case, care should be exercised, in determining the **taper** and **reinforcement**, that no weak section occurs at some distance above the ground-level.

**23. Steel Reinforcing (Fig. 36.)** When steel is embedded in well-made concrete its preservation is perfect, and the life of a reinforced monolith is practically indefinite. If designed and built with the same attention now given other materials, reinforced concrete poles should attain the necessary **strength** and give satisfactory service.

The present practice differs rather widely as to the most economical or most desirable distribution of reinforcement. It is now generally conceded, in reinforced concrete work, that the finer the **distribution** of metal, the greater the **homogeneity** and **strength** of the construction. However, in the case of poles where the concrete is deposited within narrow forms, other conditions partly modify or control the distribution.

In construction, such as concrete poles or other work, in which there is a relatively large and important amount of reinforcing, great care must be exercised to thoroughly **tamp** or **puddle** the concrete as it is deposited, in order to prevent **pockets**, and to insure every lineal inch of metal having a firm **adherence** to the concrete. In such structures, the increase in stress in the reinforcement must be very rapid, and the additions of stress are dependent upon the **efficiency** of the connection between the steel and the concrete. **Mechanical bond** or **deformed bars**, i. e. twisted squares or bars with various projections in their surfaces are superior to smooth bars for work in which high stresses must be developed in short lengths. Rods may often be bent into hooks or clamped together to advantage.

Reinforcing metal may be either **medium grade steel** with an ultimate strength of 60,000 to 70,000 pounds per square inch and an elastic limit of 30,000 to 40,000 pounds per square inch and capable of being bent cold about its own diameter, or it may be **high carbon steel** with an ultimate strength of 80,000 to 100,000 pounds per square inch, and an elastic limit of 40,000 to 60,000 pounds per

## CONCRETE POLES

Sec. 2

square inch, and capable of being bent cold about a radius equal to four times the diameter of the rod. Since the elastic limits of these two grades of material are quite different, they will have a very



FIG. 34.—Forms for concrete poles and method of loading for transportation.

marked effect upon the design and there will be no similarity between two poles of the same dimensions and reinforcement in which different grade rods are used. Owing to the fact that in a



FIG. 35.—Solid concrete pole forms (Illustrates various stages of manufacture.)

## CONCRETE POLES

### Sec. 2

pole the stresses in the reinforcement must change rapidly in amount with every lineal foot of the pole, it is most essential, at least for high strength poles, to use mechanical bond or twisted bars. It is also necessary to provide diagonal or spiral reinforcing when poles are to be subjected to torsion, although the close spacing of horizontal ties will be of assistance. The horizontal ties are needed primarily to restrain the rods from local buckling with consequent spalling off of concrete. The rods should be tied to the horizontal straps or other secondary system at each intersection, in order to assist in developing bond stress. In view of the character of service to

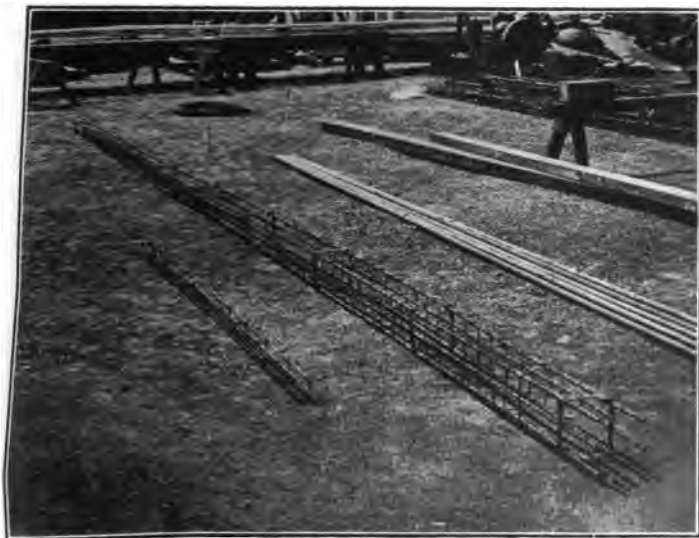

FIG. 36.—Steel reinforcement for solid concrete pole and cross-arm.

which horizontal bands or spacers are subjected, the use of cast rings or bands is inadvisable.

**24. Concrete Mixture.** The most commonly used mixture is 1 : 2 : 4 Portland Cement, sand, and broken stone or gravel. It should be mixed wet, using carefully selected materials and tamped or churned to eliminate air-bubbles, obtain a good surface, and thorough contact with the reinforcement. Such a mixture when well made has an average compressive strength of about 900 pounds per square inch in seven days, 2400 pounds per square inch in one month, 3100 pounds per square inch in three months and 4400 pounds per square inch in six months. If conditions make it desirable to

## Sec. 2

## CONCRETE POLES

use **high working stresses**, a month or more should elapse before new poles undergo severe tests.

**25. Molding Pole.** The bolt holes and step bolt sockets must be cast in place during the concreting. **Hardwood blocks** may be used for step bolts, although a **cast or spiral socket** is preferable.

No attempt should be made to remove the forms until the concrete has obtained a **good set**, and care must be exercised to prevent injury

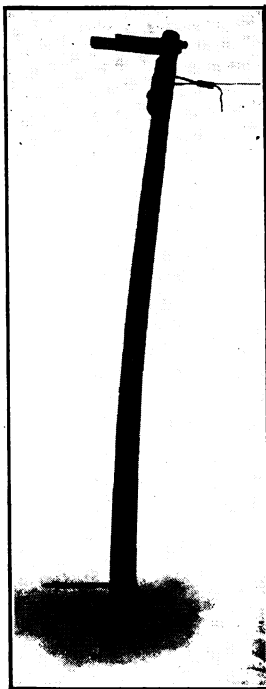

FIG. 37.—Illustrating flexibility of concrete poles.

to the surfaces during such removal. The forms should be kept covered during setting, particularly when exposed to direct sunlight in hot weather, and the concrete pole should be well sprinkled and kept under canvass for some days after the forms have been removed. A freshly made concrete pole cannot be handled or rolled with impunity until it has become well set. Further, the subsequent handling, particularly of long poles, must be done with care, and is pref-

erably done by slings attached at two separate points. Plastering the surface of poles to remove pockets or to produce a finished surface is particularly objectionable. The former should be avoided by proper workmanship, and the latter is unnecessary since a very fine surface can readily be produced by rubbing.

If we may judge by the kind of handling which concrete poles successfully withstand, it would seem entirely probable that concrete poles, if properly reinforced, will survive any shocks incident to ordinary service. When subjected to any overload or accidental shock, a timber pole will bend and in some cases survive; but failure, when it does occur, is usually complete, and the pole falls.



FIG. 38.—Hollow concrete poles manufactured by the Centrifugal Process.

Concrete poles on the contrary, while without the elasticity of timber, do not fall by breaking off, but are held by the reinforcement from falling to the ground. Tests also show that a reasonable amount of bending (sufficient for the balancing of stresses in the wires) can occur without apparent injury to the pole. (Fig. 37.)

26. **Hollow Concrete Poles** have been used quite extensively in Europe. Their manufacture is usually a machine process, there being two general methods employed.

The first method is the centrifugal. (Fig. 38.) This process consists in manufacturing poles in revolving forms by centrifugal force. A wet mixture of rich concrete is placed in a tubular form, inside which the reinforcement metal has been fastened, and revolved at high speed. It is claimed that the centrifugal

action forces the concrete to an even thickness against the reinforcement, the operation taking place in a warm room and occupying but a few minutes. These hollow poles when set have the butts filled with stones to the ground line.

In the second method an interior form or **mandrel** is used instead of an exterior shell as in the centrifugal process, and after fitting the steel reinforcement on this, a fairly dry mixture of concrete is mechanically plastered, on the revolving mandrel in a narrow continuous belt, by means of a combination of conveyor and wrapping of canvas under tension, wound spirally the length of the pole. It is claimed that both this and the centrifugal process have given very satisfactory results in Europe.



FIG. 39.—Hand-made hollow concrete pole (collapsible core.)

Hollow concrete poles have been made by hand in this country, in which the core is made collapsible and is removed as soon as the concrete has set sufficiently to bear its own weight. (Fig. 39.)

Another method consists in molding poles in forms similar to those used for solid poles. When the mold is about one-third poured, a hollow, conical galvanized iron core is inserted in the mold and the remainder of the concrete and reinforcement is put in place. The core is wrapped loosely with a spiral of building paper, which facilitates the removal of the core after the concrete has set. The poles are constructed in a horizontal position and reinforced with four, six and eight bars, as desired. The top of the mold is left open for pouring the concrete and when it is filled the concrete is tamped down and troweled off smooth.

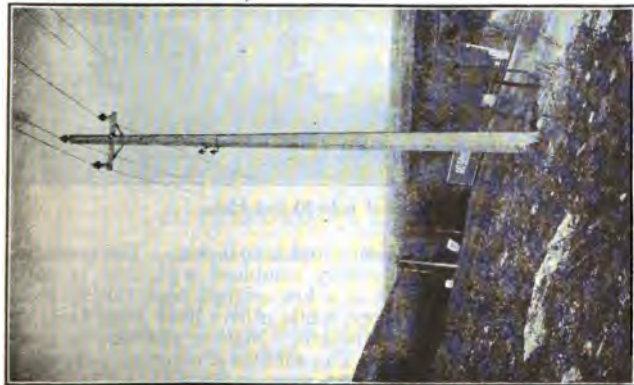

Fig. 40.—Concrete pole supporting transmission line.



Fig. 41.—Concrete pole for distribution lines.



Fig. 42.—Concrete pole for distribution lines.



When the form is filled, the concrete is allowed to set for several hours; the core is then partially removed and the pole is allowed to set from twenty-four to forty-eight hours longer. The pole is cured by wetting it thoroughly each day for twenty-five to thirty days.

It is an established fact that satisfactory concrete poles can be made and are now in service. The only consideration would seem



FIG. 43.—Steel pole 30 feet high.

to be that of **mechanical efficiency** and actual cost. The question of mechanical efficiency is in reality combined with that of cost. Concrete poles have been built at a low original cost, but with an equally low mechanical efficiency, while others have been built at excessive cost and excessive strength. Neither extreme is good engineering or good economics. The successful concrete pole must be one that has a strength at least comparable with a Class "A"

wood pole, the cost of which, including maintenance, replacement, etc. when considered for a term of years, will be not more than that of an equally satisfactory wood pole.



FIG. 44.—Double circuit three-phase 66,000 volt steel pole.

**27. STEEL POLES AND TOWERS**

Steel poles and towers may be divided into five general classes:

- (a) Patented Poles. (Art. 28.)
- (b) Tubular Steel Poles. (Art. 29.)
- (c) Latticed Structural Steel Poles. (Art. 30.)
- (d) Structural Steel Towers. (Art. 31.)
- (e) Flexible Frames. (Art. 32.)

Height of Pole.	TWO SECTION POLES.						THREE SECTION POLES.					
	MINIMUM SIZE.			MAXIMUM SIZE.			MINIMUM SIZE.			MAXIMUM SIZE.		
	Size Butt.	Weight.	Max. Load.	Size Butt.	Weight.	Max. Load.	Size Butt.	Weight.	Max. Load.	Size Butt.	Weight.	Max. Load.
22	3	169	267	13	1661	10727	4	259	438	13	1972	9436
23	3	177	280	13	1733	10034	4	266	413	13	1977	8888
24	3	181	235	13	1792	9426	4	278	391	13	1999	8407
25	3	188	221	13	1864	8688	4	278	371	13	2060	7976
26	3	196	209	13	1936	8407	4	287	352	13	2143	7587
27	3	198	199	13	1968	7976	4	291	336	13	2113	7294
28	3	205	189	13	2087	7587	4	299	331	13	2172	6913
29	3	212	180	13	2179	7234	4	308	306	13	2130	6618
30	3	220	172	13	2201	6913	4	312	295	13	2109	6345
31							4	320	283	13	2469	6099
32							4	331	273	13	2526	5869
33												
34												
FOUR SECTION POLES.												
35	5	451	446	13	2619	5656	4	331	238	13	2589	5656
36	5	462	430	13	2685	5457	4	337	242	13	2622	5457
37							4	346	235	13	2688	5272
38							4	356	235	13	2760	5099
39							4	367	239	13	2832	4937
40	5	505	377	13	2944	4785						

NOTE.—Columns headed "Size Butt" give the nominal size of pipe used in the butt section. The upper sections are each one inch, pipe size, smaller than the section next below, except that  $2\frac{1}{2}$ -inch is used in 3-inch.

Columns headed "Maximum Load" give the load that pole will carry, applied 18-inches below the top when pole is planted or "fixed" for a distance of 6 feet. It is figured at 27,000 pounds per square inch fiber stress in the material.

28. **Patented Steel Poles** are manufactured by a number of companies and can be secured in various heights. The design varies considerably but the manufacturers of such poles furnish data on their strength, from which data calculations can be made, enabling the computation of safe working loads.

29. **Tubular Steel Poles** are standardized by steel tube manufacturers. Their use is confined chiefly to trolley construction and



FIG. 45.—Single circuit three-phase 30,000 volt steel pole.

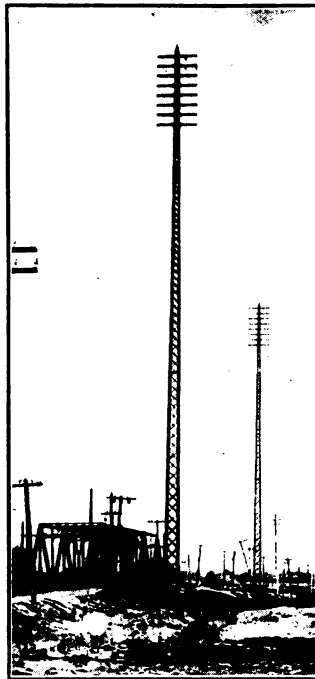

FIG. 46.—Guyed steel pole, 13,200 volts.

to supports for street lighting units. Such poles are made of two, three, four or more different lengths of standard or special steel tubing of various sizes and it is advisable, when ordering such poles, to confine the selection to standard sections, for in such standard poles the length of the various sections have been selected so that their manufacture results in a minimum waste of material.

## Sec. 2

## STEEL POLES

Table No. 5, on page 143, has been compiled from data published by a manufacturer and gives the extreme weights (light and heavy) and the respective strength of standard tubular steel poles of the two, three and four section type in lengths of from 22 feet to 40 feet.

30. **Structural Steel Poles and Towers** are in general specially designed for the particular conditions of the line in question.

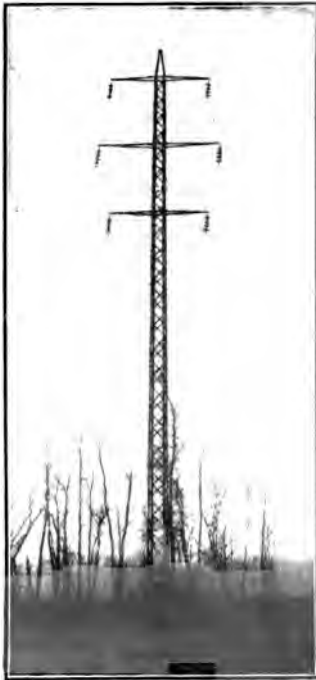

FIG. 47.—Double circuit three-phase steel pole.

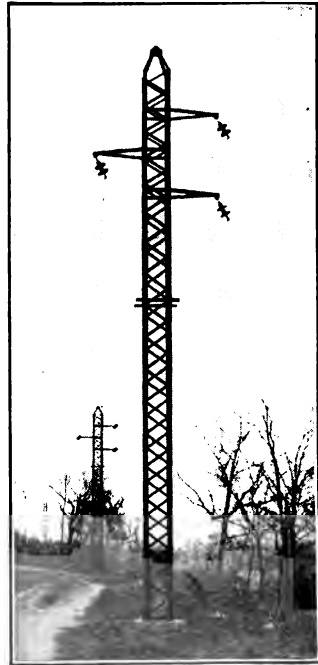

FIG. 48.—Single circuit three-phase steel pole.

Their design is so diversified and is dependent on such a variety of conditions that the subject cannot be covered in detail, also such poles are usually purchased through designing engineers, and, therefore, only the important features of design will be discussed.

If a given line is to be designed in a logical manner and with a minimum of cut and try methods, an assumption of the various

loads and the desired factors of safety must be made. Such assumptions will enable the designer to mentally predetermine, to some extent, the general nature of the supports, or at least to narrow the field of choice.

These assumptions are based primarily on the weight of the conductor plus the assumed ice and wind load, in addition to which it

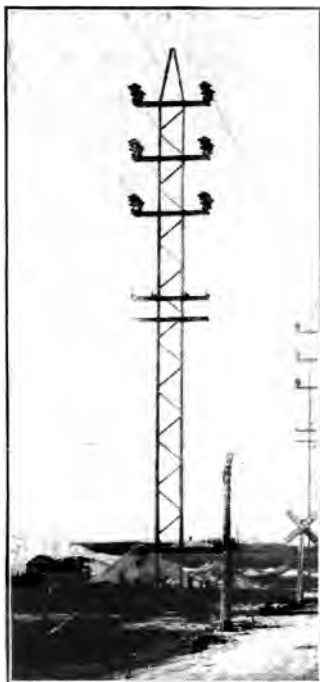

FIG. 49.—Double circuit narrow base flexible steel frame three-phase 60,000 volts.

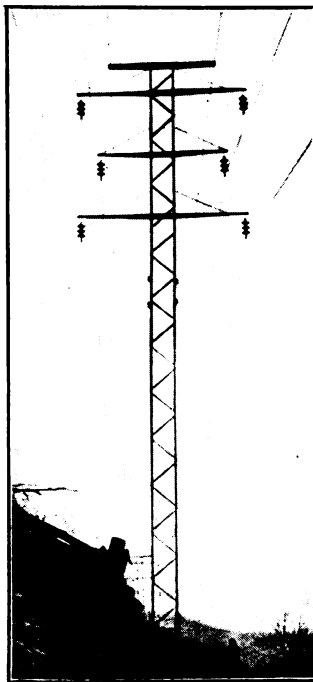

FIG. 50.—Double circuit narrow base flexible steel frame three-phase 44,000 volts.

is sometimes specified that the structure must care for one or more broken wires under the assumed loaded conditions.

In some instances the test loads which sample towers or poles must withstand are specified. Unfortunately for the entire success of this procedure the test load is very rarely an accurate representation of the possible maximum, nor is the condition of the test structure similar to that of many of the structures as installed. Test

## Sec. 2

## STEEL POLES

loads are almost always applied regularly and slowly; and in many cases uncentrically. The test structure will have at least a fairly good foundation and be composed of members free from incipient bends or other effects of mishandling. It would also be very well bolted together and plumbed with greater accuracy than the average line structure. In general, it may be said that an expert structural



FIG. 51.—Single circuit three-phase steel "A" frame 60,000 volts.

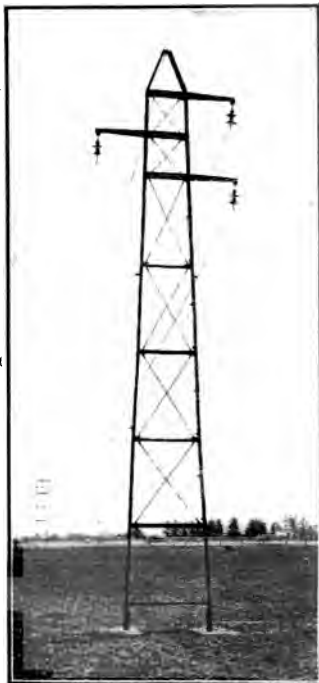

FIG. 52.—Single circuit three-phase steel "A" frame 60,000 volts.

assembler should be able to obtain test loads quite noticeably in excess of the presumptive average strength of the finally erected structures.

It would seem, moreover, that the period of usefulness of this practice is past, and that competent designers should be able to produce structures having an actual strength much nearer their predetermined strength, than the actual loads will be to the assumed loads.

The failure of a steel pole or tower will almost invariably be due to the buckling of a main compression member and this may or may not be superinduced by inefficient bracing. Owing to the possible application of the load from the opposite side of the structure, line supports must have the same main compression section at each corner, regardless of the tension stress. The compression stress per

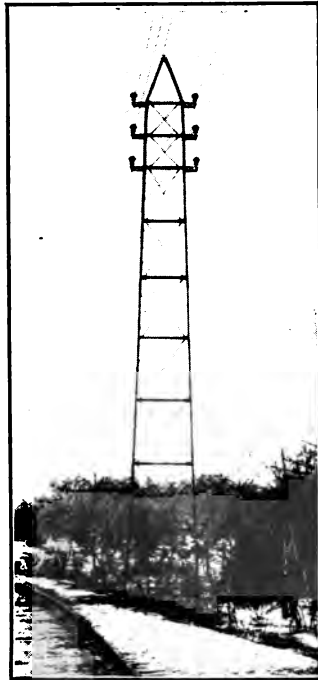

FIG. 53.—Double circuit three-phase steel "A" frame 35,000 volts.

square inch in the main legs is, therefore, the first and most important determination. A secondary condition to be borne in mind during the foregoing calculations is that the selected section must be of a size suitable for the connection of the desired bracing.

A long slender member is not well adapted to take compression and it has been customary in other work to limit the relation of the length to the radius of gyration. In transmission line construc-



## Sec. 2

## STEEL POLES

tion very much higher values of this ratio have been used than are generally permitted in other work. It is probably not necessary to adhere to the low limits of building construction, but it is equally probable that in some cases heretofore, too much latitude has been taken.

Inasmuch as the strength of the main leg members of the pole

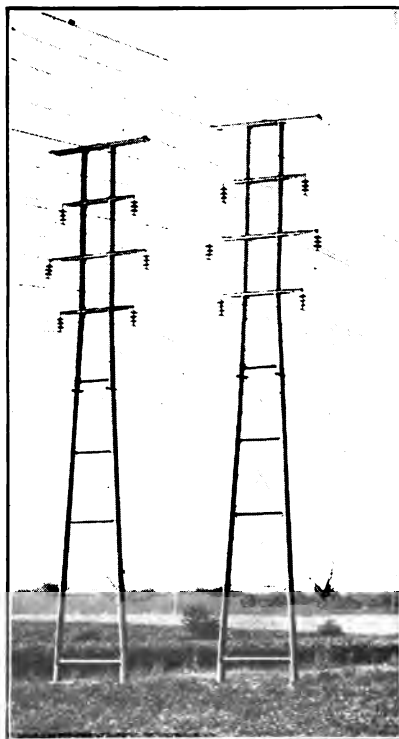

FIG. 54.—Double circuit three-phase steel "A" frames.

or tower, as well as most of the bracing, is predicated upon their strength as compression members, the most important requirement of a specification next to the broken wire condition, is the formula for compression members known as the column formula.

Unfortunately, the many column formulae in existence are stated in terms of safe working unit stresses, which renders them, unless

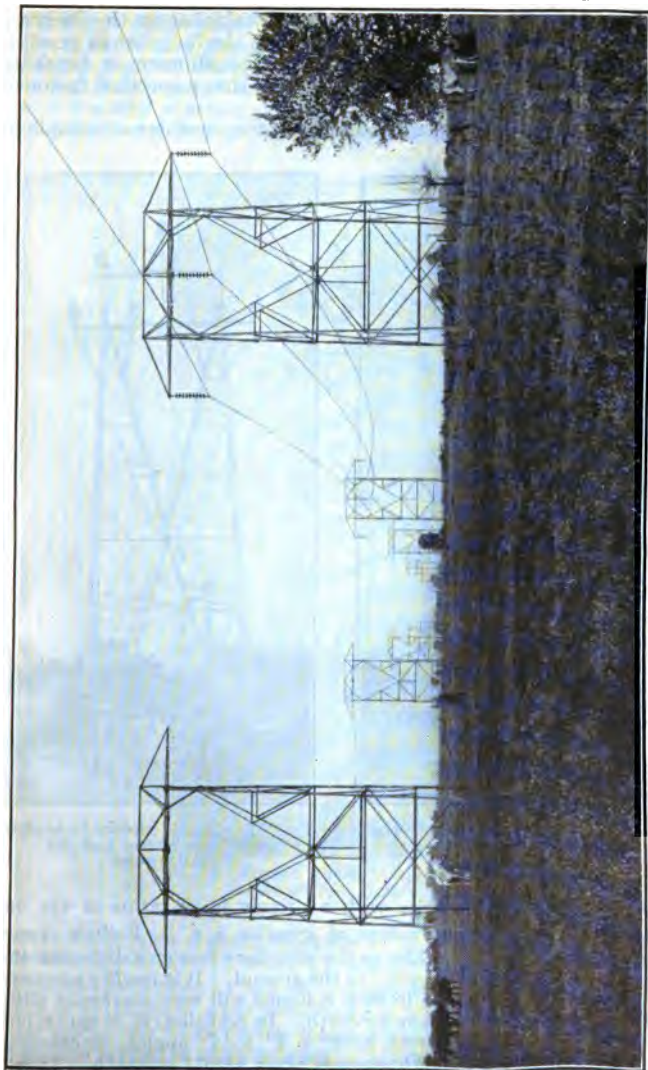

FIG. 55.—Steel transmission line towers three-phase 150,000 volts.

their factor of safety is known, almost valueless to the inexpert transmission line designer. This is due to the fact that in general, in transmission line construction, it is the ultimate or breaking strength that is to be determined in order that a specified factor of safety may be applied thereto.

In pole and tower design, the compression members are simple in

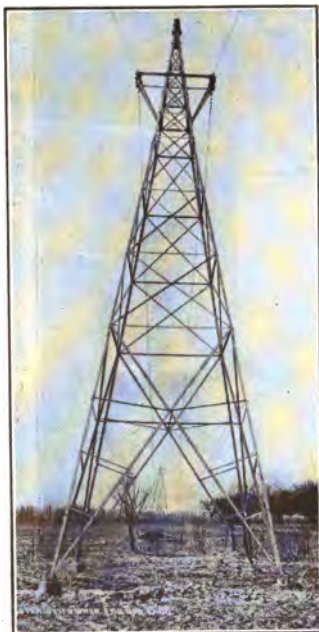

FIG. 56.—Single circuit three-phase steel tower 50 feet high for 66,000 volts.



FIG. 57.—Double circuit three-phase steel tower, 50 feet high, for 66,000 volts.

type, usually single angles with relatively large ratios of the unsupported length to the radius of gyration i. e.  $\frac{l}{r}$ . Failure occurs when such members buckle, as the structure becomes distorted and useless, though it may not fall to the ground. It is readily apparent that any incipient bends in such columns will very markedly affect the theoretical compressive strength. In addition, it is quite possible to select sections such as 4" x 4" x  $\frac{1}{4}$ " angles, or example, whose theoretical strength exceeds their actual strength. This s

due to the fact that in such large thin sections, failure may start by the local buckling of the legs of the angle.

The function of lacing is to stiffen the connected members by reducing the unsupported length of the compression section and also to transmit shearing stresses. If the shear is relatively large, the limiting condition may be the number of rivets connecting the



FIG. 58.—Double circuit steel corner tower, 40 feet high.

lattice to the main section, otherwise it will be the stiffness of the lattice bar itself; that is, the lattice is a compression member whose strength depends upon its ratio of stiffness or  $\frac{1}{r}$ . Since the minimum radius of gyration, of a flat section or bar is much smaller than that of an angle, the unsupported length of the former must be less. Again flat lacing is more subject to accidental injury than angle lacing because a slight bend in the direction of the thickness may

easily occur and make the theoretical compressive strength negligible.

When **double lacing** is used, some reduction in effective length may be assumed as provided by the connection at the intersection. In the case of flat lacing, however, it is not proper to assume the



FIG. 59.—Double circuit steel tower,  
40 feet high.

effective length as the distance from the end hole to the intersection. Owing to the larger value of the radius of gyration of an angle section, as compared with a flat section, the former allows a considerable increase in the width of the main members with less material in the lacing. Apart from the avoidance of excessive inclinations, the available angle section may depend upon the size of the bolt needed to transmit stress, or if the lacing is turned in, on the permissible end and edge distances.

## STEEL POLES

## Sec. 2

The bracing of secondary members, if they are not liable to accidental injury or torsion, may properly be allowed larger ratios than that of main compression members which, from their position, may be subject to both.

The **horizontal flanges** of horizontal or inclined angles should

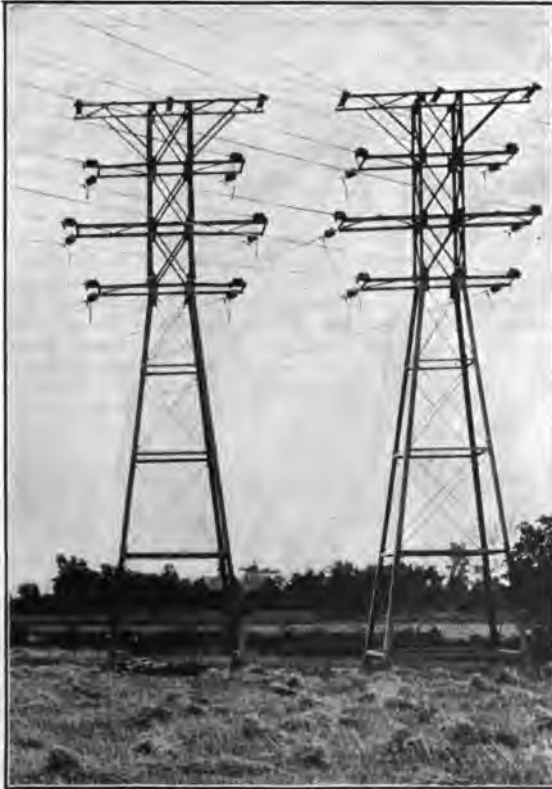

FIG. 60.—Double circuit steel corner towers.

always be turned up, as this position drains and dries quickly and does not collect dirt or hold water. Similar reasoning will prohibit the use of any closed pockets or semi-closed pockets anywhere in

the structure, as they are certain to become clogged with refuse and filled with water. Since moisture is a necessary condition of all decay and corrosion, rapid and thorough drainage are prime requisites of a good design whether the material be timber or steel.

One bolt connections should be prohibited in the main bracing system of wide base towers, except possibly for the connection of

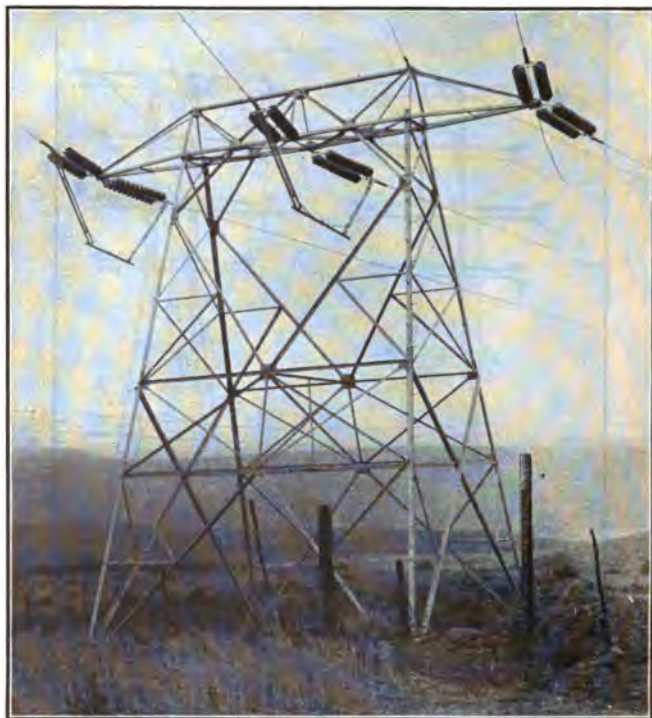

FIG. 61.—Single circuit steel anchor tower at corner, 150,000 volts.

such secondary members as sub-panel struts, whose sole function is to reduce the unsupported length of another member.

Square latticed structural steel poles may be of any width from the true narrow base poles used along curb lines to the wide base poles which are in reality towers. There is no fixed dividing line

between a pole and a tower, unless it be that of strength and rigidity, or possibly the use of widths which preclude shop riveting and shipment assembled. The greater number of the structural steel poles used are square in cross-section, one angle at each corner, and are assembled and riveted before shipment. In the case of long poles, it will frequently be found advantageous to ship in two sections and bolt them together in the field. There is no reasonable objection to the use of such field bolts, provided a splice is used of sufficient length and strength. The splice angle can be made an interior splice, with the root of the angle ground to fit the fillet of the main legs and thus be comparatively unobtrusive in the final appearance of the pole.

Several types of poles are in use, the most common being those with a regular taper or those with parallel legs. Parabolic slopes have been used and they present a very graceful appearance under favorable conditions, although the rapid increase in width for longer poles may result in an inconvenient spread at the ground line.

The design of square latticed poles resolves itself into a determination of the stresses at the ground line or rather in the first panel above ground. This statement is based upon the assumption that owing to the adoption of greater top widths than in wood poles, the upper portion of the pole has an excess width as compared with the lowest panel. It is further predicated upon there being no attempt made to seriously reduce the sections of the material in the upper half. In the case of parabolic slopes, stress determinations must be made at various heights since the widths presumably follow, more or less closely, the changes in bending moment and the weakest section may be anywhere.

Owing to the more rigid form of the frame, the breaking strength per unit of area in a pole will exceed that in a wide base tower. Again, since the main legs have little inclination, the web system is compelled to carry the shearing stresses, which in a tower are partly carried by the main legs. For these reasons, the web or lattice is more often limited by the strength required than in the bracing of a wide tower. The shearing stress must, therefore, be computed and the lattice and its connection to the main legs be designed accordingly. Single flat lacing should not be used except for small stresses and in narrow widths, since, as previously stated, its strength is low and it is subject to injury. Double flat lacing is applicable to greater stresses and widths, but is often not as economical as angle lacing. In any case the strength of the pole depends upon the unit strength of the weakest unsupported length, which is usually the lowest panel, but may be the entire pole if the width is small and the height great. That is, the  $\frac{1}{2}$  of the entire cross-section of the pole may be greater than that of an individual panel. The character and spacing of the lattice will determine to a large extent the amount of support afforded by it to the main leg angles at the panel joints.

When the lacing connects to both faces of the pole at the same



## Sec. 2

## STEEL POLES

elevation, the unsupported length of main leg is the distance between panel joints. If, however, the lacing is staggered, so that the support is in one direction only at each panel point, the unsupported length of main leg is somewhere between a half and a whole panel length.

**31. Flexible Towers.** Assuming that a reasonable amount of skill has been employed in the selection of spans, heights and main

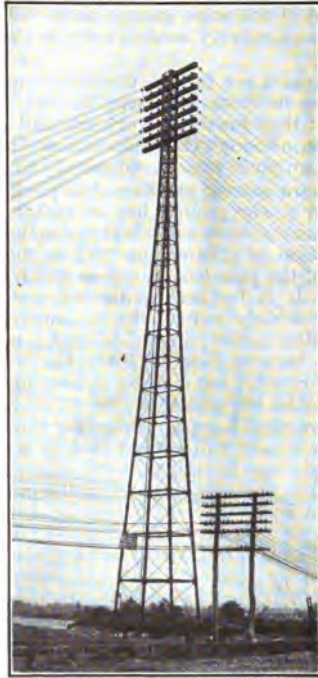

FIG. 62.—Steel tower at river crossing.

section, the most important provisions for an adequate A frame line are the installation of an overhead ground wire and substantial foundations. The ground wire, which should be of considerable strength, may properly be given a little less sag than the conductors, thus acting as a continuous head guy, the usefulness of which can hardly be overestimated. In fact, it is extremely difficult to string

the power cables unless there is a ground wire in place to steady the frame.

The conditions which promote buckling are not very clearly understood, or rather their limits are not definitely known. If the main channels are assumed to be of absolutely identical material and the base of the foundation is firm and unyielding, some degree



FIG. 63.—Double circuit three-phase steel corner tower, 50 feet high, for 66,000 volts.

of difference in the lateral support at the ground line, or of the rigidity of the bracing connections, may allow sufficient deflection to start the buckling. As the failure is a compressive failure in a relatively long column, any measures which restrain such a column from moving sideways at any point will be of effective service. Thus a comparatively long stiff connection of the bracing to the

main legs is useful as it stiffens this column locally. Such connections, therefore, should never be of less than two rivets and preferably of not less than 6" in length. Further, the diagonal braces should not have any slack and, if made of rods or adjustable members, should be tightened as near equally as possible.



FIG. 64.—River crossing steel tower,  
169 feet high.

The present tendency is toward the use of galvanized ground stub angles, whether the superstructure is painted or galvanized and with either concrete or earth back filling. Galvanizing such members is a relatively inexpensive operation and they can be painted over the galvanizing at the ground line. No reduction of section on account of the protective coating should be made in the ground stubs.

Typical structural steel poles, towers and flexible frames are illustrated in Figs. 43 to 65.

**32. Outdoor Substations.** Outdoor transformer and switching substations vary in design from the simple transformer supported

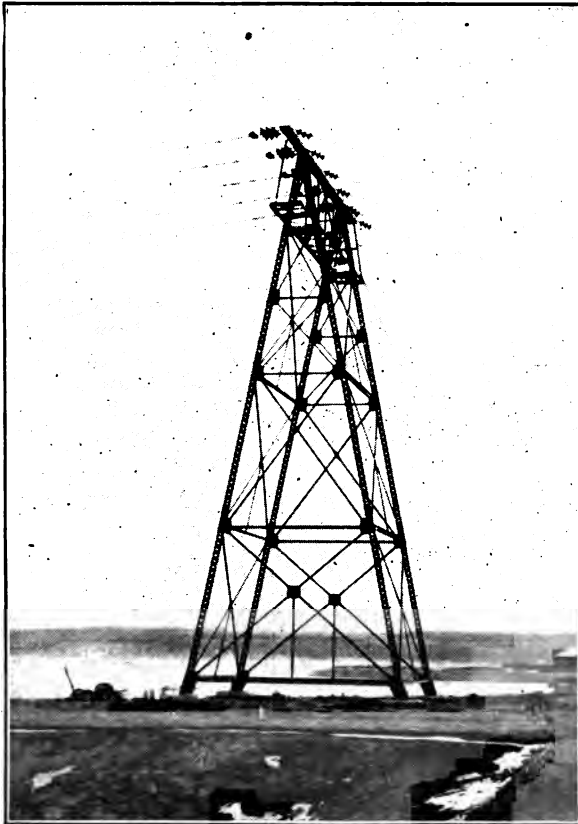

FIG. 65.—Double circuit river crossing, three-phase, 66,000 volts, 2,000 feet span

on wood poles to the more complex steel structures supporting switches and transformers of large capacity. A number of types are illustrated in Figs. 66 to 76.



FIG. 66.—Outdoor sub-station, three-phase 3-2000 kv-a transformers, 101,100 volts to 13,200 volts, 60 cycles.

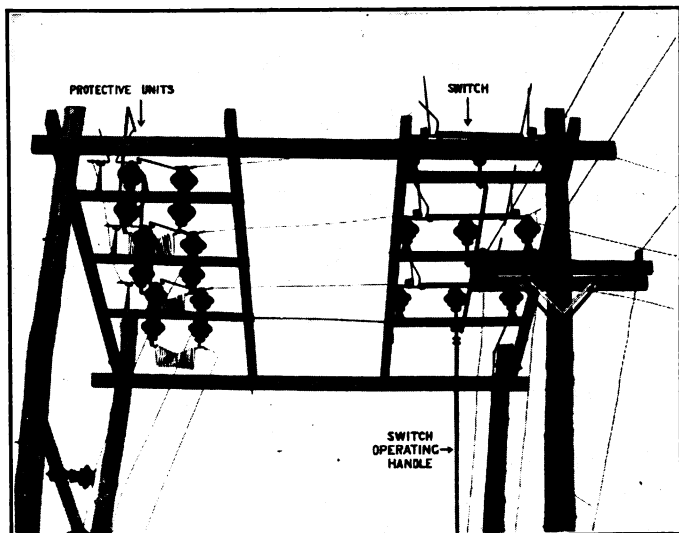

FIG. 67.—Outdoor sub-station, three-phase, 33,000 volts, illustrating air-break switches and lightning protection devices.

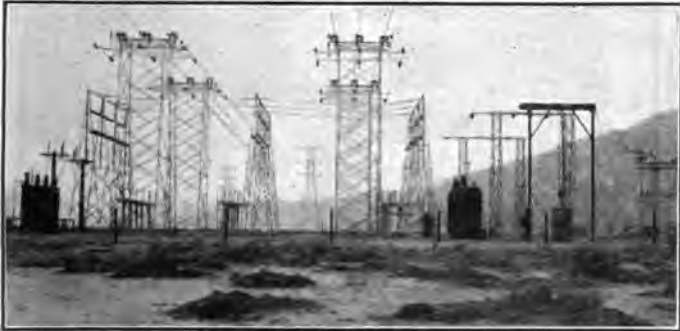

FIG. 68.—Outdoor sub-station, three-phase, 150,000 volts to 33,000 volts, 60 cycles.

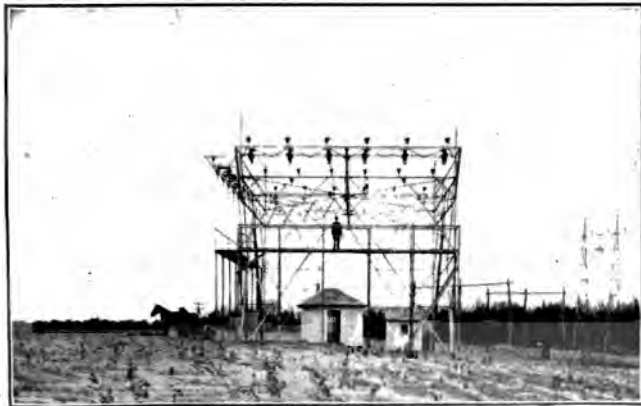

FIG. 69.—Outdoor sectionalizing and branch tower, three-phase, 66,000 volts.

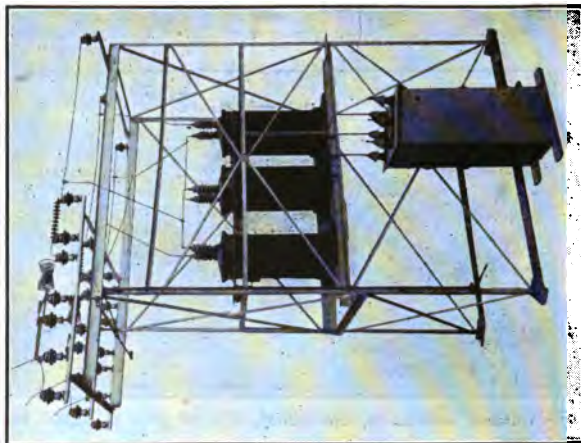

Fig. 71.—Outdoor sub-station, three-phase 3-75 kv-a, 60 cycle transformers. Rural service from a 35,000 volt transmission line.



Fig. 70.—Outdoor sub-station, three-phase 2-50 kv-a, 33,000/12,300 volt, 60 cycle transformers.

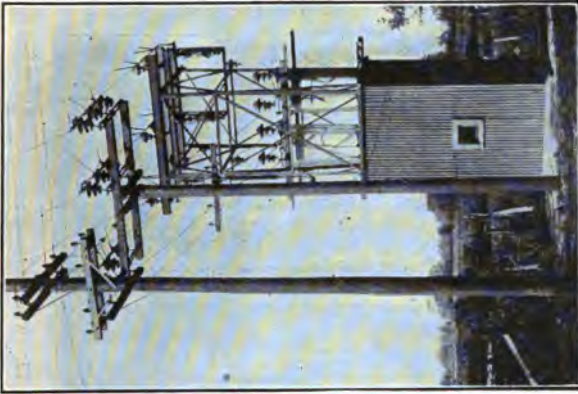

FIG. 73.—Outdoor sub-station, three-phase 2-50 kv-a, 33,000/2,200 volt, 60 cycle transformers. Switches on pole in foreground.

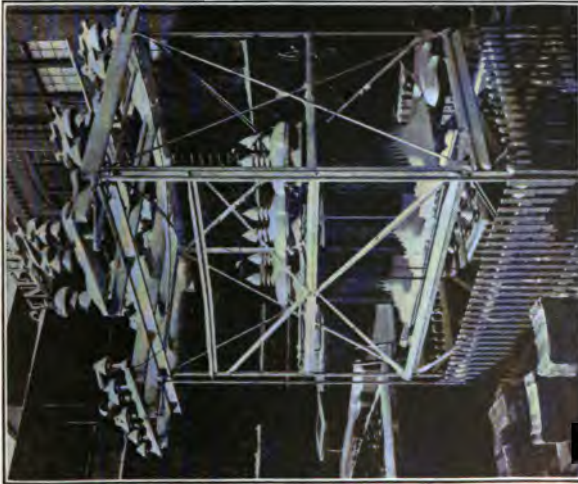

FIG. 72.—70,000 volt sub-station after a heavy snow storm.



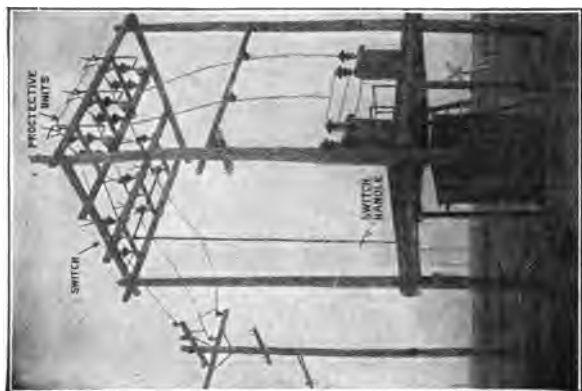

Fig. 75.—Wood outdoor sub-station for 33,000 volts, three-phase.

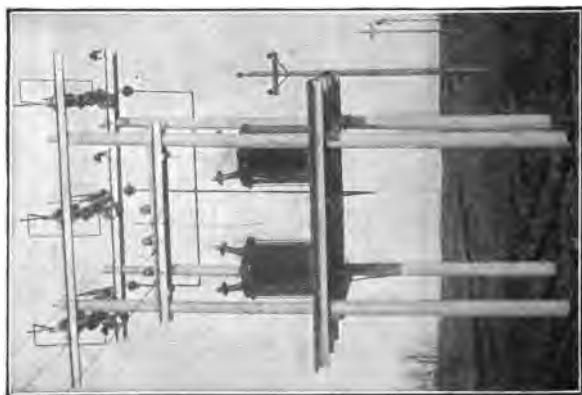

Fig. 74.—Wood outdoor sub-station for 22,000 volts, three-phase.

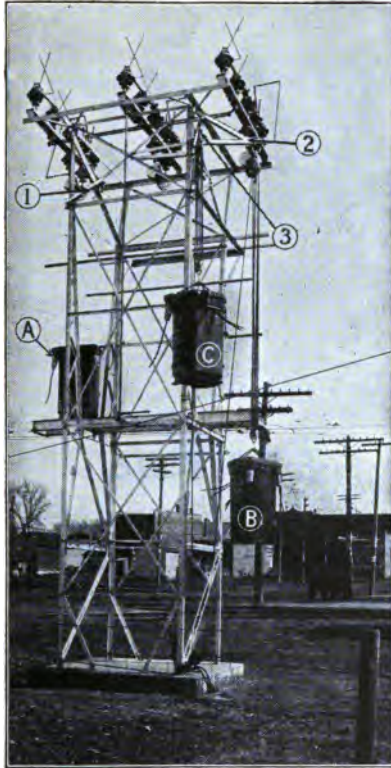
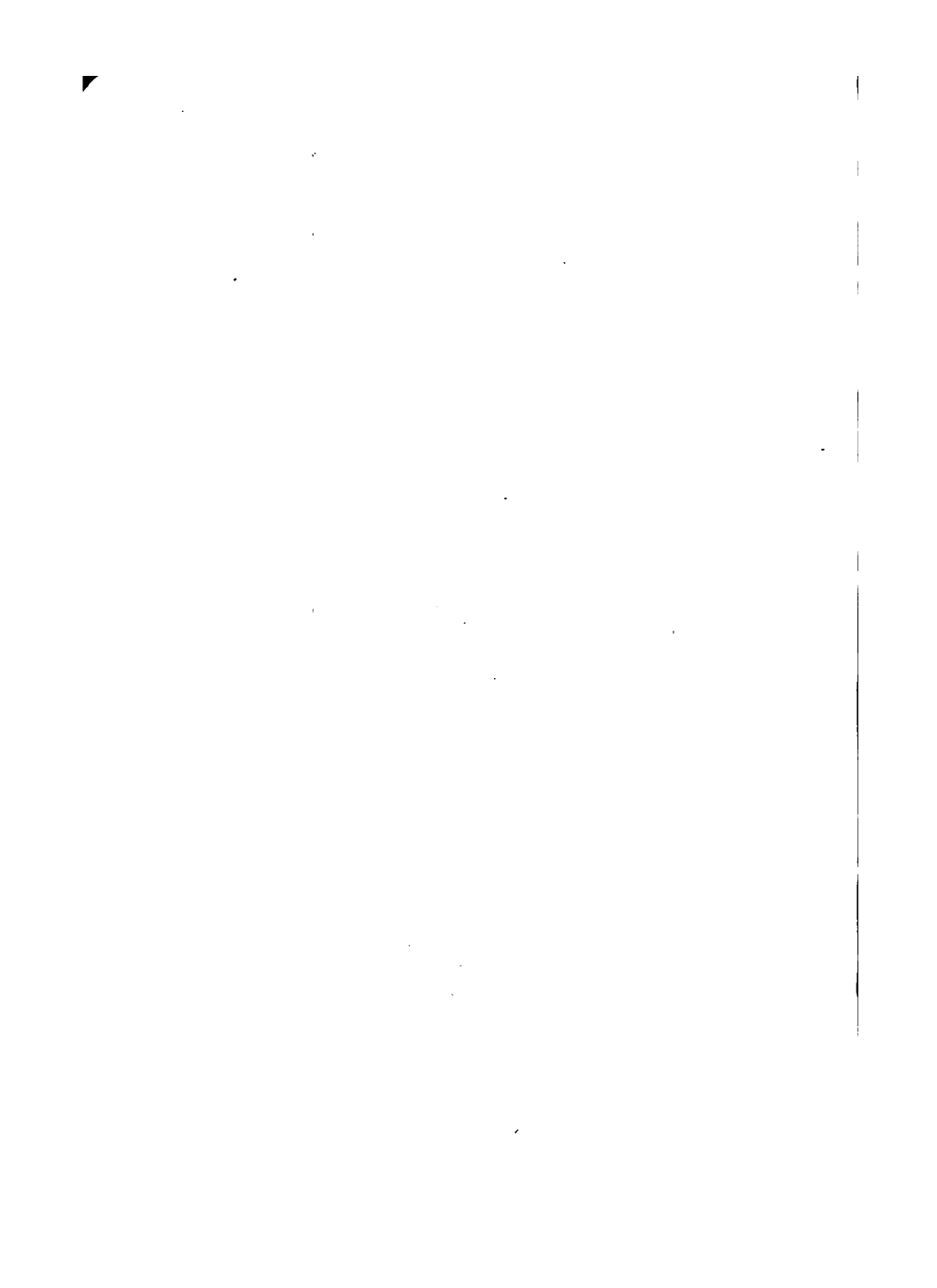

FIG. 76.—Steel outdoor sub-station for 33,000 volts. 1, 2 and 3 are jib cranes for handling transformers A, B, and C, respectively.

### BIBLIOGRAPHY.

United States Government Reports.  
N. E. L. A. Publications.  
Electrical World.  
Current News, Philadelphia Electric Company.  
American Telephone and Telegraph Company.  
Transmission Line Construction, Lundquist.  
Publications of Various Manufacturers.



## **SECTION 3**

### **CONDUCTORS AND WIRE TABLES**



**SECTION 3**  
**CONDUCTORS AND WIRE TABLES**

---

**TABLE OF CONTENTS**

	<b>ARTICLE</b>
<b>Production and Refining of Conductor Material</b>	
Copper ores and their reduction . . . . .	1
Aluminum ores and their reduction . . . . .	2
Iron and steel ores and their reduction . . . . .	3
Copper Clad Wire . . . . .	4
<b>Manufacture of Wire</b>	
Working Ingots . . . . .	5
Wire Drawing . . . . .	6
Weatherproofing . . . . .	7
Rubber Insulation . . . . .	8
Application of Rubber Compound . . . . .	9
Vulcanizing . . . . .	10
Protection of Insulation . . . . .	11
<b>Physical Characteristics . . . . .</b>	<b>12</b>
Tables 6 to 10 inclusive.	
<b>Units of Resistance . . . . .</b>	<b>13</b>
Table 11.	
<b>Specific Resistance . . . . .</b>	<b>14</b>
<b>Specific Conductivity . . . . .</b>	<b>15</b>
<b>Percentage Conductivity . . . . .</b>	<b>16</b>
<b>Matthiessen's Standard of Conductivity . . . . .</b>	<b>17</b>
Table 12.	
<b>Specific Resistance, Relative Resistance and Relative Conductivity of Conductors . . . . .</b>	<b>18</b>
Table 13.	
<b>Temperature Coefficient . . . . .</b>	<b>19</b>
Table 14.	
Table 15.	
Table 16.	
<b>American Steel and Wire Gauge . . . . .</b>	<b>20</b>
<b>Brown and Sharpe Gauge . . . . .</b>	<b>21</b>
<b>Birmingham Gauge . . . . .</b>	<b>22</b>

### Sec. 3 CONDUCTORS AND WIRE TABLES

	ARTICLE
Comparison of Wire Gauges.....	23
Table 17.	
Law of the Brown and Sharpe Gauge.....	24
Table 18.	
Wire Strands.....	25
Table 19.	
Illustrations of Bare Wire, Strand and Cable.....	26
Heating Effects of Current.....	27
Table 20.	
Table 21.	
Fig. 77.	
Table 22.	
Table 23.	
Table 24.	
Effective Resistance.....	28
Table 25.	
Figs. 78-81 inclusive.	
Explanation	
Guy Wire.....	29
Table 26.	
Extra Galvanized Special Strands.....	30
Table 27.	
Table 28.	
<b>Copper, Aluminum, Copper Clad and Iron Wire Tables</b>	
<b>Total Pounds Pull Required to Break Wire</b>	
Solid wire	Table 29.
Stranded wire	Table 30.
<b>Diameters of Wires, Bare and T.B.W.</b>	
Solid wire	Table 31.
Stranded wire	Table 32.
<b>Weights of Wires, Bare and T.B.W.</b>	
Solid wire	Table 33.
Stranded wire	Table 34.
<b>Resistance of Wires</b>	
Solid wire	Table 35.
Stranded wire	Table 36.
<b>Self-inductance</b>	
Solid wire	Table 37.
Stranded wire	Table 38.

## CONDUCTORS AND WIRE TABLES

Sec. 3

### Capacity

Solid wire	Table 39.
Stranded wire	Table 40.

ARTICLE

### Inductive Reactance

Solid wire, 25 cycles	Table 41.
Solid wire, 60 cycles	Table 42.
Solid wire, 100 cycles	Table 43.
Stranded wire, 25 cycles	Table 44.
Stranded wire, 60 cycles	Table 45.
Stranded wire, 100 cycles	Table 46.

### Charging Current

Solid wire, 25 cycles	Table 47.
Solid wire, 60 cycles	Table 48.
Solid wire, 100 cycles	Table 49.
Stranded wire, 25 cycles	Table 50.
Stranded wire, 60 cycles	Table 51.
Stranded wire, 100 cycles	Table 52.

### Stranded Aluminum Wire Equal in Conductivity to Copper Table 53.

### Correction for Internal Inductance of Copper Clad Wire . . . . 31 Figs. 84-87 inclusive.

### Average Track Resistance Table 54.

### Specifications

Specifications for Galvanized Steel Strand . . . . .	32
Specifications for Copper Wire and Cables with Weather Proof Insulation . . . . .	33
Specifications for Bare Hard Drawn Copper Wire and Strand . . . . .	34
Specifications for Hard Drawn Copper Clad Steel Wire . . . . .	35
Specifications for Aluminum Wires and Cables, Weatherproof Insulation . . . . .	36
Specifications for Bare Aluminum Wire . . . . .	37
Specifications for Rubber Insulated Tree Wire Braided . . . . .	38
Specifications for Circular Loom Covered Tree Wire . .	39





## CONDUCTORS AND WIRE TABLES

In the section following, data are compiled on conductors and conductor material, in which some general information is given on the production and refining of the conductor material and also a brief description of wire drawing and insulating.

These data have been collected with the cooperation of various wire manufacturers. A comparison of the diameters, weights, strengths, etc., of the various sizes of wire, as produced by different manufacturers, indicated certain discrepancies and therefore, it was necessary to confine the data on any particular wire material to that furnished by one manufacturer. These discrepancies were slight, however, and the tables given herein will be found sufficiently accurate to apply to any standard product which may be purchased. The tables have been compiled in a form thought to be most conducive to rapid calculation and contain only such wire sizes as are considered **standard**.

## PRODUCTION AND REFINING OF CONDUCTOR MATERIALS

**1. Copper.** Copper ores occur in many and various forms in widely distributed localities. In the United States there are three localities in which the copper mineralization is of considerable magnitude. Approximately 95 percent of the total copper ore of the country is mined in the **Lake Superior, Rocky and Sierra Nevada Mountain** regions.

The copper bearing rocks in the **Lake** district are very distinctly stratified beds of trap, sandstone and conglomerates which rise at an angle of about 45 degrees from the horizontal sandstone which forms the basin of Lake Superior. One peninsula extending into the **Lake** has developed copper in profitable amounts, almost chemically pure.

The amount of copper in the ore as mined averages about 3 percent, the balance being rock, which is intimately mixed with the metal. The ore is first subjected to a mechanical process whereby the metal is concentrated into a small bulk and the rock rejected. "**Lake**" copper is so pure that final melting without refining is practicable.

The deposits in the **Rocky Mountains** and in the **Sierra Nevadas** show all phases of formation from the original unaltered sulphide deposits to the most highly altered oxides and carbonates.

A **Sulphide ore** is an ore in which copper appears in chemical combination with sulphur and in some cases is first roasted or heated so that the sulphur is burned off, leaving the copper and iron, which is usually present, in an oxidized or burned form. In another process the raw unroasted ore is thrown into a furnace, the sulphur itself burned and made to smelt the mass, producing, on account of its chemical nature, a highly impure, yet very valuable, compound

### Sec. 3 CONDUCTORS AND WIRE TABLES

with iron and sulphur, called **matte**. This **matte**, which is about half copper, is poured from the furnace into a **converter** and the iron and sulphur are burned out, by blowing through great volumes of air. The result of this operation is **blister copper**, so called, on account of the blistered appearance of the surface caused by the quantities of gases absorbed by the metal.

If copper ore occurs in an oxidized or carbonate form, or roasted ore is used, a blast furnace is also utilized for the reduction. Oxidized or sulphide ores are also often mixed and the **matte** is **blown**.

Blister copper contains about 99 percent of copper, which is not, however, pure enough for use as a conductor material. If a sufficient amount of precious metal is contained in it, the electrolytic refining process is used, by which method the blister copper is dissolved and the chemically pure copper separated from the impurities and other metals.

The blister copper or **electrolytic copper** is then charged into a refining furnace and melted by means of a very pure fuel. The furnace is a simple bowl shaped hearth, covered and provided with doors for skimming and stirring. After the metal is quickly melted and the last traces of sulphur have been removed by combination with the oxygen from the flame, the process known as **rabbling** or **flapping** is begun. This is a violent agitation of the metal through one of the side doors, by means of small rabblers or pokers. During the flapping, samples are frequently taken in a hemispherical mould about an inch in diameter. When the set or appearance of the solidified metal in this mould indicates that sufficient work has been done upon it, the surplus oxygen is removed in order to prevent extreme brittleness and the lack of conductivity incident to an over-oxidized metal. This is done by **poling** the bath. A large stick of green hardwood is introduced into the bath, which burns and the metal is violently agitated by the gas driven off. The surface of the bath is covered with charcoal to prevent further oxidation, and samples are very frequently taken. This is continued until the test piece shows **tough pitch** or the removal of the excess of oxygen, and that the metal is in its toughest condition. This tough pitch condition is essential for the requirements of rolling and wire drawing, as copper in this state possesses the highest degree of conductivity and is of an extremely tough and ductile nature. The metal is then poured into ingot-moulds or wire bars, in which form it goes to the wire manufacturer.

**2. Aluminum.** Although aluminum is a component part of a very large portion of the earth's crust, forming an essential part of all granites, gneisses, clays and other very numerous and complex silicates, there are very few natural compounds of aluminum which are suitable for use as ores for the production of the pure metal.

The only compound at present used, from which aluminum is produced, is **bauxite**, which is hydrated aluminum oxide with oxides of iron, silicon and titanium as impurities. Ordinary clays are so high in silicon that the separation of the aluminum from the silicon is

extremely difficult. More or less extensive deposits of bauxite are found in **Arkansas, Georgia, France, Ireland** and in a few other places.

Before bauxite can be subjected to the smelting process, it must be refined and purified to remove from it the last possible trace of silicon, iron and titanium, water and other impurities, which may be present in it as mined. Since there is no method available for the further purification of aluminum when once it has been obtained in the metallic state, its purity depends almost entirely upon the purity of the ore used. The bauxite is therefore put through an elaborate chemical process, as a result of which it is delivered to the ore reduction plants in the form of practically chemically pure aluminum oxide, or **alumina**.

This pure alumina is then subjected to the smelting or reduction process, which is purely **electrochemical** in its nature. This is carried on in large rectangular iron tanks or pots, which are thickly lined with carbon which also serves as one electrode for the very heavy electric current required. The other electrode consists of a group of cylindrical carbons suspended above and serving to lead the current into the tank or pot.

The details of the reduction process vary slightly at different plants, but fundamentally the processes are all the same and consist of the electrolytic decomposition of alumina. The alumina so electrolysed is first dissolved in a flux or fused bath of a suitable aluminum salt, which is maintained in a molten condition by the joulean heat of the current passing through the pot. The alumina (aluminum oxide) thus carried in solution is broken up into metallic **aluminum** and **oxygen**. The metallic aluminum, which collects at the bottom of the pots, is tapped off at stated intervals and the oxygen combines with the carbon electrode forming **carbon dioxide**.

In order to produce aluminum of a purity sufficient for electrical conductor purposes, only the purest ore can be used and at all stages of the process great care must be exercised to avoid the introduction of impurities into the metal.

The extra pure metal so obtained, after being analyzed and classified according to purity, is sent to the smelting furnaces, where it is carefully melted in large open hearth furnaces and cast into wire bars, in which form it goes to the wire manufacturer.

**3. Iron and Steel.** The distribution of iron ores follows in a general way those of copper statistics showing that the states of **Michigan, Wisconsin** and **Minnesota** produce about 80 percent of the total ore mined in the United States.

The southern states, **Alabama, the Virginias, Tennessee, Kentucky, Georgia, Maryland** and **North Carolina** contribute about 12 percent of the country's supply. The balance is distributed quite widely along the Atlantic Coast range, the Mississippi Valley and **Rocky Mountains**.

Practically all of the ores commercially utilized are in an **oxide** or **carbonate** combination so that a simple heating to the reducing

### Sec. 3 CONDUCTORS AND WIRE TABLES

point of the ore in contact with a proper reducing material is sufficient to bring about the first step in the process.

The ore, as mined, consists of two main constituents, the valuable material which contains the iron and quantities of rock and other materials from which the metallic part must be separated. The ore is charged, as a whole, into the furnace and the proper mixing with non-metallic substances relied upon to form the final products which are easily fusible, and from which the liquid iron will separate itself by reason of its greater specific gravity. The flux as these additions are called, is usually limestone, as the gangue is usually of a silicious nature.

The ore, fuel, and fluxes are charged into a blast furnace, which is a cylindrical stack 80 to 100 feet high and about 20 feet in diameter at its largest point, having suitable arrangements near its base for blowing in great volumes of air. The fuel used is coke, which heats the charge to its melting point and at the same time frees the iron from its chemical bonds in the ore. The earthy portions of the ore unite with the limestone, forming a waste product known as slag. The carbon in the coke combines with the oxygen in the oxide of iron, thus separating the metallic iron from the ore.

The metal from these furnaces is called Pig Iron and is employed mainly in this shape as a stepping stone toward other products.

Pig Iron is coarse-grained, brittle and full of impurities, which must be removed. This is done by several processes in one of which the pig is mixed with steel scrap of a highly selected grade and the molten mass subjected for several hours to the purifying action of an intensely hot flame, by which the various impurities are eliminated. The metal is then poured into iron moulds, which shape it into ingots. The ingots are taken out of the moulds as soon as the outside has firmly solidified and are plunged in a deep, white hot pit, where they are kept until their temperature is uniform throughout. After this they are sent to the wire manufacturer.

**4. Copper Clad.** Copper clad wire is composed of a steel core around which is formed a copper sheath, varying in thickness in accordance with the grade of wire, which sheath is practically welded to the steel core.

In one process of the manufacture of such wire, a steel billet, of a suitable composition for wire making, is carefully pickled and washed, then heated to a given temperature and lowered into a furnace containing molten copper, at a very high temperature, where it is allowed to remain until an alloy forms on the billet's surface. The billet is then inserted in a mould of such a diameter that a space remains around the billet into which space chemically pure molten copper is poured. This is allowed to set; the billet is then rolled to wire rod which is put through the ordinary process of wire drawing.

In another process there is first formed a two-metal or composite ingot by inserting a bar of high grade steel of suitable length and uniform cross section into and in close contact with a seamless

copper tube of high conductivity and physical qualities, and of equal length and exactly finished thickness,—the diameter of the core and thickness of the copper being accurately predetermined in order to give the proper proportion of each metal in the finished product. The two-metal ingot thus formed is then placed in a heating furnace and there brought to a temperature suitable for welding. While still hot, and with both copper and steel in a plastic or pasty condition, they are taken to the rolls and there the two metals are welded together.

### MANUFACTURE OF WIRE

**5. Working Ingots.** The treatment of copper, aluminum, copper clad or steel is practically the same. The material is received in approximately the same size and length, is heated and then passed through a rolling mill, reducing the size and finally producing a rod which may be a quarter of an inch in diameter and nearly a quarter of a mile in length.

Up to this point the metal has been handled hot, but during the processes of wire drawing it is worked in the cold state.

**6. Wire Drawing** consists briefly in pulling the wire through tapering holes in iron or steel plates, reducing its diameter and increasing its length with each draft until the wire has undergone a sufficient number of drafts and consequent reductions to bring it to the proper diameter.

When the finer sizes of wire are to be produced, the total reduction cannot be made in one series of drafts, as the wire must be treated at intervals to relieve the strains produced by the cold working. This treatment, called **annealing**, consists in heating the metal uniformly to a sufficiently high temperature to remove the internal molecular strains and to make the metal once more soft and ductile. This may be repeated many times before the necessary amount of reduction has been attained. The finest sizes of magnet wire are produced by drawing through holes drilled in diamonds.

**7. Weatherproof Insulation.** In the manufacture of triple braided weatherproof wire, the wires are covered by three closely and evenly woven braids of strong fibrous material after which they are placed in a hot bath of weatherproof insulating compound. They remain in this bath until the fibrous insulation is completely and thoroughly saturated. After thoroughly drying, the wire receives a dressing of mineral wax and the surface is then thoroughly finished and polished.

**8. Rubber Insulation.** There are various grades of crude rubber usually known under the name of the country or seaport from which they come, such as "Para," "Ceylon," etc.

Rubber for insulation purposes must be free from impurities, such as bark and sand. This cleansing is done by passing the crude rubber several times between corrugated steel rolls, revolving at different speeds and under a constant stream of water. Thus the

### Sec. 3 CONDUCTORS AND WIRE TABLES

rubber is washed and cleansed from such impurities and is delivered in a sheet ready to be dried. Crude rubber is affected by changes in temperature, hardening with cold and softening and losing its shape with heat. In such an uncured state it readily oxidizes and is particularly susceptible to the action of certain solvents. To obtain the properties needed in the insulation of a wire, the rubber must be compounded with other materials and then vulcanized.

Compounding consists of mixing the rubber with other substances, chiefly powdered minerals, including a small percentage of sulphur. After the rubber has been warmed to a plastic condition in the heated mixing rolls, which are smooth and run at different speeds, the compounding ingredients are added to the rubber and the whole is thoroughly kneaded together by the action of the mixing rolls, until the resulting compound is homogeneous in nature and of suitable physical condition.

**9. Application of the Rubber Compound.** Two different methods are commonly in use for applying rubber insulation to wires. In one, a machine similar in action to a lead press is used. The rubber is forced by a revolving worm into a closed chamber at high pressure, at the same time being heated to a soft and plastic state by a steam jacket. The wire enters this same chamber through a nozzle of its own diameter, and leaves it from a nozzle having the diameter of the intended insulation. The wire thus comes out with a seamless coating of rubber insulation.

In the other method of application, the rubber is sheeted on a calender having heavy smooth rolls and the sheets thus made are cut into narrow strips, the width and thickness of which depends upon the size of the wire to be insulated and the number of covers to be used. In this method the wire is passed between one or more pairs of grooved rolls running tangent to each other. As the wire enters each pair of rolls, one or more strips of rubber enter at the same time and the grooves fold a uniform thickness of rubber about the wire, the edges meeting in a continuous seam. All surplus rubber is cut off by the rolls at the seams. These seams being made between two pieces of the same unvulcanized cohesive stock under very great pressure, become invisible in the finished wire and can be determined only by a ridge along the insulation.

In the process of vulcanizing, the rubber at the seams is kneaded together so that the insulation at this point is as dense and homogeneous as at any other part of the insulation.

**10. Vulcanizing.** To vulcanize rubber compounds they are subjected to temperatures somewhat above the melting point of sulphur, which temperatures are usually obtained by use of steam under pressure. This operation causes the sulphur in the compound to unite chemically with the rubber and other ingredients of the compound, with the results that the rubber is no longer plastic, but becomes firm, elastic, strong, less susceptible to heat and cold, to the action of the air and less readily affected at ordinary temperatures, by the usual solvents of unvulcanized rubber. Its chemical

and mechanical properties depend considerably on the time and the temperature of vulcanization and on the amount of sulphur used.

**11. Protection of Rubber Insulation.** Rubber insulation for aerial work should be protected by a winding of tape, or by a braid, or a tape and one or more braids. The tape used consists of a good grade of cloth filled with a high class rubber compound. The braiding consists of a strong cotton yarn, knitted tightly and evenly about the insulation by a machine resembling a stocking machine.

The braid is then saturated with a black weatherproof compound, which is waxed and polished.

**12. PHYSICAL CHARACTERISTICS.** The average physical characteristics of copper, aluminum, copper clad, steel and iron wire are given in Tables 6 to 10 inclusive. While copper clad is a compound wire consisting of copper and steel, it will be noted that its characteristics differ from both those of copper and steel.

The physical characteristics of compound stranded cables, such as copper steel core and aluminum steel core cables have not been included, since the relative proportions of the compounding vary to such an extent with the mechanical and electrical conditions to be obtained by such compounding, that such cables are practically a special product.



<b>TABLE 6</b>		
<b>COPPER WIRE</b>		
<b>Physical constants of commercial wire. Average values</b>		
	Annealed	Hard
Percent Conductivity (Matthiessen's Standard 100)	99-102	96-99
Specific Gravity . . . . .	8.89	8.94
Pounds in 1 cubic inch . . . . .	.320	.322
Pounds per 1000 ft. per circular mil . . . . .	.003027	.003049
Elastic Limit in lbs. . . . .	28,000	30-35,000
Ultimate Strength $\frac{\text{lbs.}}{\text{sq. in.}}$ . . . . .	32-34,000	50-57,000
Modulus of elasticity $\frac{\text{lb.} \times \text{in.}}{\text{in.} \times \text{sq. in.}}$ . . . . .	12,000,000	16,000,000
Coefficient of Linear Expansion per ° C. . . . .	.0000171	.0000171
Coefficient of Linear Expansion per ° F. . . . .	.0000095	.0000095
Melting Point in ° C. . . . .	1100°	1100°
Melting Point in ° F. . . . .	2012°	2012°
Specific Heat (watt-seconds to heat 1 lb. 1° C.) . . . . .	176	176
Thermal Conductivity (watts through cu. in., temperature gradient 1° C.) . . . . .	8.7	8.7
<b>Resistance:</b>		
Michroms per centimeter cube 0° C. . . . .	1.594	1.626
Microhms per inch cube 0° C. . . . .	.6276	.6401
Ohms per mil-foot 0° C. . . . .	9.59	9.78
Ohms per mil-foot 20° C. . . . .	10.36	10.57
Resistance per mile 0° C. . . . .	<u>50,600</u>	<u>51,600</u>
	Cir. Mils	Cir. Mils
Resistance per mile 20° C. . . . .	<u>54,600</u>	<u>55,700</u>
	Cir. Mils	Cir. Mils
Pounds per mile ohm 0° C. . . . .	810	830
Pounds per mile ohm 20° C. . . . .	875	896
Temperature Coefficient per ° C. . . . .	.0042	.0042
Temperature Coefficient per ° F. . . . .	.00233	.00233

<p><b>TABLE 7</b> <b>ALUMINUM WIRE</b> Physical constants of commercial wire. Average values</p>	
	Aluminum Wire
Percent Conductivity (Matthiessen's Standard 100) . . . . .	<b>61</b>
Specific Gravity . . . . .	<b>2.68</b>
Pounds in 1 cubic inch . . . . .	<b>.0967</b>
Pounds per 1000 ft. per circular mil. . . . .	<b>.000920</b>
Elastic Limit . . . . .	<b>14000-16000</b>
Ultimate Strength $\frac{\text{lbs.}}{\text{sq. in.}}$ . . . . .	<b>23000-27000</b>
Modulus of elasticity $\frac{\text{lb.} \times \text{in.}}{\text{in.} \times \text{sq. in.}}$ . . . . .	<b>9,000,000</b>
Coefficient of Linear Expansion per ° C. . . . .	<b>.0000231</b>
Coefficient of Linear Expansion per ° F. . . . .	<b>.0000128</b>
Melting Point in ° C. . . . .	<b>657°</b>
Melting Point in ° F. . . . .	<b>1215°</b>
Specific Heat (watt-seconds to heat 1 lb. 1° C.) . . . . .	<b>412</b>
Thermal Conductivity (watts through cu. in., temperature gradient 1° C. at 100° C.) . . . . .	<b>3.85</b>
<b>Resistance:</b>	
Microhms per centimeter cube 0° C. . . . .	<b>2.612</b>
Microhms per inch cube 0° C. . . . .	<b>1.628</b>
Ohms per mil-foot 0° C. . . . .	<b>15.72</b>
Ohms per mil-foot 20° C. . . . .	<b>16.97</b>
Resistance per mile 0° C. . . . .	<b>83050</b>
	Cir. Mils
Resistance per mile 20° C. . . . .	<b>89650</b>
	Cir. Mils
Pounds per mile ohm 0° C. . . . .	<b>403.5</b>
Pounds per mile ohm 20° C. . . . .	<b>435.6</b>
Temperature Coefficient per ° C. . . . .	<b>.0039</b>
Temperature Coefficient per ° F. . . . .	<b>.0022</b>

<b>TABLE 8</b>		
<b>COPPER CLAD WIRE</b>		
<b>Physical constants of commercial wire. Average values</b>		
	30%	40%
Percent Conductivity (Matthiessen's Standard 100)	29¼%	39%
Specific Gravity . . . . .	8.25	8.25
Pounds in 1 cubic inch . . . . .	.298	.298
Pounds per 1000 feet per circular mil . . . . .	0.00281	0.00281
Ultimate Strength $\frac{\text{lbs.}}{\text{sq. in.}}$ . . . . .	60,000	100,000
Modulus of elasticity $\frac{\text{lb.} \times \text{in.}}{\text{in.} \times \text{sq. in.}}$ . . . . .	19,000,600	21,000,000
Coefficient of Linear Expansion per ° C. . . . .	.000012	.000012
Coefficient of Linear Expansion per ° F. . . . .	.0000067	.0000067
Melting Point in ° C. . . . .	..	..
Melting Point in ° F. . . . .	..	..
Specific Heat (watt-seconds to heat 1 lb. 1° C.) . . . . .	..	..
Thermal Conductivity (watts through cu. in., temperature gradient 1° C.) . . . . .	..	..
Resistance:		
Microhms per centimeter cube 0° C. . . . .	..	..
Microhms per inch cube 0° C. . . . .	..	..
Ohms per mil-foot 0° C. . . . .	..	..
Ohms per mil-foot 20° C. . . . .	35.5	26.6
Resistance per mile 0° C. . . . .	..	..
Resistance per mile 20° C. . . . .	<u>187,000</u>	<u>140,000</u>
	Cir. Mils	Cir. Mils
Pounds per mile ohm 0° C. . . . .	..	..
Pounds per mile ohm 20° C. . . . .	2,775	2,075
Temperature Coefficient per ° C, from 0° C. . . . .	.0044	..
Temperature Coefficient per ° F, from 32° F. . . . .	.0024	..

<b>TABLE 9</b>			
<b>STEEL WIRE</b>			
<b>Physical constants of commercial wire. Average values</b>			
	Siemens's Martin	High Strength	Extra High Strength
Percent Conductivity (Matthiessen's Standard 100).....	8.7	..	..
Specific Gravity.....	7.85	7.85	7.85
Pounds in 1 cubic inch.....	.283	.283	.283
Pounds per 1000 ft. per circular mil...	.002671	..	..
Elastic Limit.....	33000	63000	112000
Ultimate strength $\frac{\text{lbs.}}{\text{sq. in.}}$ .....	75,000	125,000	187,000
Modulus of elasticity $\frac{\text{lb.} \times \text{in.}}{\text{in.} \times \text{sq. in.}}$ .....	29,000,000	29,000,000	29,000,000
Coefficient of Linear Expansion per ° C.	.0000118	..	..
Coefficient of Linear Expansion per ° F.	.00000652	..	..
Melting Point in ° C.....	1360	..	..
Melting Point in ° F.....	2480	..	..
Specific Heat (watt-seconds to heat 1 lb. 1° C.).....	..	..	..
Thermal Conductivity (watts through cu. in., temperature gradient 1° C.)	..	..	..
<b>Resistance:</b>			
Microhms per centimeter cube 0° C. .	18.10	18.47	18.88
Microhms per inch cube 0° C.....	7.13	7.27	7.43
Ohms per mil-foot 0° C.....	108.8	111.3	113.7
Ohms per mil-foot 20° C.....	119.7	122.5	125.0
Resistance per mile 0° C.....	574,000	588,000	600,000
	Cir. Mils	Cir. Mils	Cir. Mils
Resistance per mile 20° C.....	632,600	647,000	660,000
	Cir. Mils	Cir. Mils	Cir. Mils
Pounds per mile ohm 0° C.....	8090	8270	8450
Pounds per mile ohm 20° C.....	8000	8100	8300
Temperature Coefficient per ° C.....	.00501	.00501	.00501
Temperature Coefficient per ° F.....	.00278	.00278	.00278

TABLE 10

## IRON WIRE

Physical constants of commercial wire. Average values

	B. B.	E. B. B.
Percent Conductivity (Matthiessen's Standard 100)	19.99	16.8
Specific Gravity . . . . .	7.77	7.77
Pounds in 1 cubic inch . . . . .	.282	.282
Pounds per 1000 ft. per circular mil . . . . .	.00265	.002652
Elastic Limit . . . . .	..	30,000
Ultimate strength $\frac{\text{lbs.}}{\text{sq. in.}}$ . . . . .	61,000	55,000
Modulus of elasticity $\frac{\text{lb.} \times \text{in.}}{\text{in.} \times \text{sq. in.}}$ . . . . .	..	26,000,000
Coefficient of Linear Expansion per ° C. . . . .	.000012	.000012
Coefficient of Linear Expansion per ° F. . . . .	.0000067	.00000673
Melting Point in ° C. . . . .	..	1635
Melting Point in ° F. . . . .	..	2975
Specific Heat (watt-seconds to heat 1 lb. 1° C.) . . . . .	..	209
Thermal Conductivity (watts through cu. in., temperature gradient 1° C.) . . . . .	..	1.39
Resistance:		
Microhms per centimeter cube 0° C. . . . .	11.3	9.5
Microhms per inch cube 0° C. . . . .	4.45	3.74
Ohms per mil-foot 0° C. . . . .	68.0	57.2
Ohms per mil-foot 20° C. . . . .	74.80	62.92
Resistance per mile 0° C. . . . .	<u>359,600</u>	<u>302,000</u>
	Cir. Mils	Cir. Mils
Resistance per mile 20° C. . . . .	<u>395,000</u>	<u>332,000</u>
	Cir. Mils	Cir. Mils
Pounds per mile ohm 0° C. . . . .	5,000	4,270
Pounds per mile ohm 20° C. . . . .	5,500	4,700
Temperature Coefficient per ° C. . . . .	.005	.005
Temperature Coefficient per ° F. . . . .	.00278	.00278

13. **UNITS OF RESISTANCE.** The unit of resistance now universally used is the International Ohm.

The following table gives the value and relation of the principal practical units of resistance which existed prior to the establishment of the International Units. (Table 11.)

TABLE 11				
Unit	International Ohm	B. A. Ohm	Legal Ohm 1884	Siemens's Ohm
International Ohm .....	1	1.0136	1.0028	1.0030
B. A. Ohm .....	0.9866	1.	0.9894	1.0433
Legal Ohm .....	0.9972	1.0107	1.	1.0600
Siemens's Ohm .....	0.9407	0.9535	0.9434	1.

To reduce British Association ohms to international ohms divide by 1.0136, or multiply by 0.9866; and to reduce legal ohms to international ohms, divide by 1.0028, or multiply by 0.9972, etc.

14. **SPECIFIC RESISTANCE:**

- Let  $L$  = length of conductor.
- $A$  = cross section of the conductor.
- $R$  = resistance of the conductor.
- $\rho$  = specific resistance of the conductor.

$$\text{Then } R = \rho \frac{L}{A}$$

$$\text{or } \rho = R \frac{A}{L}$$

If " $L$ " is measured in centimeters and " $A$ " in square centimeters,  $\rho$  is the resistance of a centimeter cube of the conductor. If " $L$ " is measured in inches and " $A$ " in square inches,  $\rho$  is the resistance of an inch cube of the conductor.

In telegraph and telephone practice, specific resistance is sometimes expressed as the "weight per mile-ohm," which is the weight in pounds of a conductor one mile long having a resistance of one ohm.

Another common way of expressing specific resistance is in terms of "ohms per mil-foot," i. e., the resistance of a round wire one foot long and 0.001 inch in diameter;  $L$  is then measured in feet and  $A$  in circular mils.

Microhms per inch cube = 0.3937  $\times$  microhms per centimeter cube.

Pounds per mile-ohm

times specific gravity = 57.07  $\times$  microhms per centimeter cube.

Ohms per mil-foot = 6.015  $\times$  microhms per centimeter cube.

### Sec. 3 CONDUCTORS AND WIRE TABLES

15. **SPECIFIC CONDUCTIVITY** is the reciprocal of specific resistance. If  $c$  = specific conductivity

$$R = \frac{L}{cA}$$

$$c = \frac{L}{RA}$$

$$c = \frac{1}{\rho}$$

16. By **RELATIVE OR PERCENTAGE CONDUCTIVITY** of a sample is meant 100 times the ratio of the conductivity of the sample at standard temperature, to the conductivity of a conductor of the same dimensions made of the standard material and at standard temperature. If  $\rho_0$  is the specific resistance of the sample at standard temperature, and  $\rho_s$  is the specific resistance of the standard at standard temperature, then

$$\text{Percentage conductivity} = 100 \frac{\rho_s}{\rho_0}$$

In comparing different materials, the specific resistance should always be determined at the standard temperature, which is usually taken as 0° Centigrade. If it is inconvenient to measure the resistance of the sample at the standard temperature, this may be calculated provided the temperature coefficient  $\alpha$  of the sample is known, i. e.

$$\rho_0 = \frac{\rho_t}{1 + \alpha t}$$

where  $\rho_t$  is the specific resistance at temperature  $t$ .

17. **MATTHIESSEN'S STANDARD CONDUCTIVITY** is the commercial standard of conductivity and is the conductivity of a copper wire having the following properties at a temperature of 0° C:

- Specific gravity . . . . . 8.89.
- Length . . . . . 1 meter.
- Weight . . . . . 1 gram.
- Resistance . . . . . 141729 ohms.
- Specific resistance . . . . 1.594 microhms per cubic centimeter.
- Relative conductivity 100%.

**TABLE 12**  
**MATTHIESSEN'S STANDARD**

Equivalent length of a square mm. mercury column.	B. A. units.	Legal ohms.	International ohms.
	104.8 cms.	106.0 cms.	106.3 cms.
Resistance at 0° C. of Matthiessen's Standard—			
Meter-gram soft copper . . . .	143 65	.142 06	.141 73
Meter-millimeter soft copper . .	.020 57	.020 35	.020 3
Cubic centimeter soft copper . .	.000 001 616	.000 001 598	.000 001 594
Mil-foot soft copper . . . . .	9.72	9.612	9.59

18. SPECIFIC RESISTANCE, RELATIVE RESISTANCE, AND RELATIVE CONDUCTIVITY OF CONDUCTORS.

<b>TABLE 13</b>				
<b>Referred to Matthiessen's Standard</b>				
Metals:	Resistance in Microhms at 0° C		Relative Resistance Percent	Relative Conductivity Percent
	Centimeter Cube	Inch Cube		
Silver annealed . . . . .	1.47	.579	92.5	108.2
Copper, annealed . . . . .	1.55	.610	97.5	102.6
Copper (Matthiessen's Standard) . . . . .	1.594	.6376	100	100.0
Gold (99.9% pure) . . . . .	2.20	.865	138	72.5
Aluminum (99% pure) . . . . .	2.53	1.01	161	62.1
Zinc . . . . .	5.75	2.26	362	27.6
Platinum, annealed . . . . .	8.98	3.53	565	17.7
Iron . . . . .	9.07	3.57	570	17.6
Nickel . . . . .	12.3	4.85	778	12.9
Tin . . . . .	13.1	5.16	828	12.1
Lead . . . . .	20.4	8.04	1280	7.82
Antimony . . . . .	35.2	13.9	2310	4.53
Mercury . . . . .	94.3	37.1	5920	1.69
Bismuth . . . . .	130.	51.2	8320	1.22
Carbon (graphite) . . . . .	2400-42,000	950-16,700	..	..
Carbon (arc light) . . . . .	about 4000	about 1590	..	..
Selenium . . . . .	6 x 10 <sup>10</sup>	2.38 x 10 <sup>11</sup>	..	..

<b>GENERAL</b>		
Liquids at 18° C.	Ohms per Centimeter Cube	Ohms per Inch Cube
Pure Water . . . . .	2650	1050
Sea Water . . . . .	30	11.8
Sulphuric acid, 5% . . . . .	4.86	1.93
Sulphuric acid, 30% . . . . .	1.37	.544
Sulphuric acid, 80% . . . . .	9.18	3.64
Nitric acid, 30% . . . . .	1.29	.512
Zinc sulphate, 24% . . . . .	21.4	8.54

19. TEMPERATURE COEFFICIENT. The resistance of a conductor varies with the temperature of the conductor.

Let  $R_0$  = Resistance at 0°  
 $R$  = Resistance at  $t$   
 Then  $R = R_0 (1 + \alpha t)$ .

$\alpha$  is called the temperature coefficient of the conductor. 100  $\alpha$  is the percentage change in resistance per degree change in temperature.

The following values of the temperature coefficient have been found for temperatures measured in degrees Centigrade and in degrees Fahrenheit. The coefficients vary considerably with the purity of the conductor. (Table 15.)



TABLE 14

## TEMPERATURE COEFFICIENTS

Table of temperature variations in the resistance of pure soft copper according to Matthiessen's standard and formulæ.

Temperature in degrees Centigrade.	Temperature coefficient of resistance.	Logarithm.	Matthiessen meter-gram standard resistance.		
			B. A. units.	Legal ohms.	International ohms.
0	1.	0.	0.143 85	0.142 06	0.141 73
1	1.003 876	0.001 689 1	0.144 21	0.142 61	0.142 28
2	1.007 764	0.003 358 3	0.144 77	0.143 17	0.142 83
3	1.011 66	0.005 036 2	0.145 33	0.143 72	0.143 38
4	1.015 58	0.006 712 1	0.145 89	0.144 27	0.143 94
5	1.019 5	0.008 386 4	0.146 45	0.144 83	0.144 49
6	1.023 43	0.010 059 3	0.147 02	0.145 39	0.145 05
7	1.027 38	0.011 730 7	0.147 59	0.145 95	0.145 61
8	1.031 34	0.013 400 3	0.148 15	0.146 51	0.146 17
9	1.035 31	0.015 068 3	0.148 73	0.147 08	0.146 73
10	1.039 29	0.016 734 6	0.149 3	0.147 64	0.147 3
11	1.043 28	0.018 399 3	0.149 87	0.148 21	0.147 86
12	1.047 28	0.020 062 1	0.150 45	0.148 78	0.148 43
13	1.051 29	0.021 723	0.151 02	0.149 35	0.149
14	1.055 32	0.023 382 1	0.151 6	0.149 92	0.149 57
15	1.059 35	0.025 039	0.152 18	0.150 49	0.150 14
16	1.063 39	0.026 694	0.152 77	0.151 07	0.150 71
17	1.067 45	0.028 348	0.153 34	0.151 64	0.151 29
18	1.071 52	0.029 999	0.153 93	0.152 22	0.151 86
19	1.075 59	0.031 648	0.154 51	0.152 8	0.152 44
20	1.079 68	0.033 294	0.155 1	0.153 38	0.153 02
21	1.083 78	0.034 939	0.155 69	0.153 96	0.153 6
22	1.087 88	0.036 581	0.156 28	0.154 55	0.154 18
23	1.092	0.038 222	0.156 87	0.155 13	0.154 77
24	1.096 12	0.039 859	0.157 46	0.155 72	0.155 35
25	1.100 26	0.041 494	0.158 06	0.156 31	0.155 94
26	1.104 4	0.043 127	0.158 65	0.156 89	0.156 53
27	1.108 56	0.044 758	0.159 25	0.157 48	0.157 11
28	1.112 72	0.046 385	0.159 85	0.158 08	0.157 7
29	1.116 89	0.048 011	0.160 44	0.158 67	0.158 3
30	1.121 07	0.049 633	0.161 05	0.159 26	0.158 89
40	1.163 32	0.065 699	0.167 11	0.165 26	0.164 88
50	1.206 25	0.081 436	0.173 28	0.171 36	0.170 95
60	1.249 65	0.096 767	0.179 52	0.177 53	0.177 11
70	1.293 27	0.111 687	0.185 76	0.183 72	0.183 29
80	1.336 81	0.126 069	0.192 04	0.189 91	0.189 46
90	1.379 95	0.139 863	0.198 23	0.196 04	0.195 58
100	1.422 31	0.152 995	0.204 42	0.202 06	0.201 58

TABLE 15		
TEMPERATURE COEFFICIENTS		
Pure Metals	Centigrade α	Fahrenheit α
Silver, annealed . . . . .	0.00400	0.00222
Copper, annealed . . . . .	0.00428	0.00242
Gold (99.9%) . . . . .	0.00377	0.00210
Aluminum (99%) . . . . .	0.00423	0.00235
Zinc . . . . .	0.00406	0.00228
Platinum, annealed . . . . .	0.00247	0.00137
Iron . . . . .	0.00625	0.00347
Nickel . . . . .	0.0062	0.00345
Tin . . . . .	0.00440	0.00245
Lead . . . . .	0.00411	0.00228
Antimony . . . . .	0.00389	0.00216
Mercury . . . . .	0.00072	0.00044
Bismuth . . . . .	0.00354	0.00197

Matthiessen's formula for soft copper wire

$$R = R_0 (1 + .00387t + .00000597t^2).$$

The wire used by Matthiessen was as pure as could be obtained at the time (1860), but in reality contained considerable impurities; the above formula, therefore, is not generally applicable. Later experiments have shown that for all practical work the above equation for copper wire may be written

$$R = R_0 (1 + .0042t) \text{ for } t \text{ in } ^\circ\text{C}.$$

**TEMPERATURE COEFFICIENT OF COPPER**

A. I. E. E.

The fundamental relation between the rise of temperature and the increase of resistance of copper may be expressed thus:

$$R_t = R_{t_1} (1 + \alpha_{t_1} [t - t_1])$$

where  $R_t$  is the resistance at any temperature  $t$  deg. Cent.;  $R_{t_1}$  is the resistance at any "initial temperature" (or "temperature of reference")  $t_1$  deg. cent.; and  $\alpha_{t_1}$  is the temperature coefficient from and at the initial temperature  $t_1$  deg. cent. Obviously the temperature coefficient is different for different initial temperatures, and this variation is shown in the horizontal rows of Table 16. Furthermore, it has been shown that the temperature coefficient is different for different conductivities, and that the temperature coefficient is substantially proportional to the conductivity. The results of this simple law are shown by the vertical columns of Table 16.

**TABLE 16**  
**TEMPERATURE COEFFICIENTS OF COPPER FOR**  
**DIFFERENT INITIAL TEMPERATURES AND**  
**DIFFERENT CONDUCTIVITIES**

Ohms per meter-gram at 20 deg. Cent.	Per cent conductivity	$\alpha_0$	$\alpha_{15}$	$\alpha_{20}$	$\alpha_{25}$	$\alpha_{30}$	$\alpha_{50}$	-T "Inferred absolute zero"
0.16108	95	0.00405	0.00361	0.00374	0.00367	0.00361	0.00336	-247.2
0.15940	96	0.00405	0.00385	0.00378	0.00371	0.00364	0.00340	-244.4
0.15776	97	0.00414	0.00390	0.00382	0.00375	0.00368	0.00343	-241.7
0.15727	97.3	0.00415	0.00391	0.00383	0.00376	0.00369	0.00344	-240.9
0.15614	98	0.00418	0.00394	0.00386	0.00379	0.00372	0.00346	-239.0
0.15557	99	0.00423	0.00398	0.00390	0.00382	0.00375	0.00349	-236.4
0.153022	100	0.00428	0.00402	0.00394	0.00386	0.00379	0.00352	-233.5
0.15151	101	0.00432	0.00406	0.00398	0.00390	0.00382	0.00355	-231.3

The quantity (-T) given in the last column of Table 16 is the calculated temperature on the Centigrade scale at which copper of the particular conductivity concerned would have zero electrical resistance provided the temperature coefficient between 0 deg. Cent. and 100 deg. Cent. applied continuously down to the absolute zero. The usefulness of this "inferred absolute zero temperature of resistance" in calculating temperature rise is evident from the following formula:

$$t - t_1 = \frac{R_t - R_{t_1}}{R_{t_1}} (T + t_1)$$

The presentation of the above table is intended to emphasize the desirability of determining the temperature coefficient rather than assuming it. Actual experimental determination is facilitated by the proportional relation between the temperature coefficient and the conductivity; a measurement of either quantity gives both. However, if a temperature coefficient must be assumed, the best value to take for average commercial annealed copper wire is that given in Table 16 for 100 percent conductivity, viz.,

$$\alpha_0 = 0.00428, \alpha_{20} = 0.00394, \alpha_{25} = 0.00386$$

This is the value recommended for wire wound on instruments and machines, since they are generally wound with annealed wire, and experiments have shown that the distortions due to the winding of the wire do not appreciably affect the temperature coefficient.

If a value must be assumed for hard-drawn copper wire, the value recommended is that given in Table 16 for 97.3 percent conductivity viz.,

$$\alpha_0 = 0.00415, \alpha_{20} = 0.00383, \alpha_{25} = 0.00376$$

The temperature coefficients in Fahrenheit degrees are given by dividing any  $\alpha$  above by 1.8. Thus, the 20 deg. Cent. or 68 deg. Fahr. temperature coefficient for copper of 100 percent conductivity is 0.00394 per deg. Cent., or 0.00219 per deg. Fahr.

WIRE GAUGES

20. **AMERICAN STEEL AND WIRE GAUGE** is generally used in America for iron and steel wire.

21. **BROWN AND SHARPE GAUGE** is the standard gauge used for wires for electrical purposes, (iron and steel wire excepted).

22. **BIRMINGHAM GAUGE** is used largely in England and also in this country for wires (excepting iron wire) other than those made especially for electrical purposes.

23. **COMPARISON OF WIRE GAUGES.** The sizes of wires are ordinarily expressed by an arbitrary series of numbers. Unfortunately there are several independent numbering methods, so that it is always necessary to specify the method or wire gauge used. Table 17 gives the numbers and diameters in decimal parts of an inch for the various wire gauges used in this country and England.

TABLE 17 COMPARATIVE SIZES WIRE GAUGE IN DECIMALS OF AN INCH						
No. of Wire Gauge.	American Steel & Wire	American Standard (B. & S.)	Birmingham or Stubbs'.	British Imperial Standard.	Old English or London.	French.
0000000	.4900	..	..	.500	..	..
000000	.4815	.5000	..	.484	..	..
000000	.4835	.51550	.500	.482	..	..
0000	.4938	.46000	.454	.460	.4540	..
000	.4825	.46964	.425	.472	.4250	..
00	.4310	.46480	.480	.448	.4800	..
0	.4965	.42486	.440	.424	.4400	..
1	.4230	.42890	.400	.400	.4000	.0825
2	.4265	.42763	.484	.476	.4840	.040
3	.4487	.42942	.459	.452	.4590	.050
4	.4253	.40431	.438	.432	.4380	.0635
5	.4070	.41194	.420	.412	.4200	.068
6	.4120	.41620	.403	.412	.4030	.083
7	.4170	.41428	.410	.416	.4100	.097
8	.4160	.42043	.416	.410	.4160	.110
9	.4183	.41443	.418	.414	.4180	.120
10	.4150	.40180	.414	.418	.4140	.135
11	.4206	.40074	.420	.416	.4200	.140
12	.4185	.40081	.409	.404	.4180	.162
13	.4015	.40719	.405	.402	.4050	.172
14	.4000	.40406	.403	.400	.4030	.185
15	.4020	.40706	.402	.402	.4020	.197
16	.4025	.40082	.405	.404	.4050	.212
17	.4040	.40325	.408	.405	.4080	.225
18	.4075	.40030	.409	.408	.4090	.238
19	.4010	.40380	.402	.400	.4000	.250
20	.4043	.40196	.405	.406	.4050	.263

### Sec. 3 CONDUCTORS AND WIRE TABLES

24. **LAW OF THE BROWN AND SHARPE GAUGE.** The diameters of wires of the B. and S. gauge are obtained from the geometric series in which No. 0000 = 0.4600 inch and No. 36 = .005

TABLE 18 DIAMETER AND CROSS-SECTION AREA SOLID WIRE					
Brown & Sharpe Gauge	Diameter of Wire		Cross-sectional Area		
	In Inches	In Millimeters	Circular Mils (d <sup>2</sup> ) d = .001 Inch	Square Inch (d <sup>2</sup> x .7854)	Square Millimeter
0000	.4600	11.683	211600.	.166190	197.219
000	.4096	10.404	167772.	.131770	85.011
00	.3643	9.266	133079.	.104520	67.432
0	.3250	8.255	105625.	.082958	53.521
1	.2893	7.348	83694.	.065733	42.408
2	.2576	6.543	66358.	.052117	33.624
3	.2294	5.827	52624.	.041331	26.665
4	.2043	5.189	41733.	.032781	21.149
5	.1819	4.620	33083.	.025987	16.766
6	.1620	4.115	26244.	.020612	13.298
7	.1443	3.665	20822.	.016354	10.550
8	.1285	3.264	16512.	.012969	8.3666
9	.1144	2.906	13087.	.010279	6.6313
10	.1019	2.588	10384.	.0081553	5.2614
11	.0907	2.304	8226.5	.0064611	4.1684
12	.0806	2.052	6528.6	.0051276	3.3081
13	.0720	1.829	5184.0	.0040715	2.6267
14	.0641	1.628	4108.8	.0032271	2.0819
15	.0571	1.450	3250.4	.0025697	1.6329
16	.0508	1.290	2580.6	.0020268	1.2976
17	.0453	1.151	2052.1	.0016117	1.0398
18	.0403	1.024	1624.1	.0012756	.82294
19	.0359	.919	1288.8	.0010122	.65394
20	.0320	.8128	1024.0	.00080425	.51887

inch, the nearest fourth significant figure being retained in the areas and diameters so deduced. Brown and Sharpe tables are derived from the following formulae:

Let

n = gauge number (0000 = -3; 000 = -2; 00 = -1).

d = diameter of wire in inches.

Cir. mils = area in circular mils.

r = resistance in ohms per 1000 ft. at 20° C.

w = weight in pounds per 1000 ft.

Then

$$d = \frac{0.3249}{1.123^n}$$

$$\text{Cir. mils} = \frac{105,500}{1.261^n}$$

$$r = 0.09811 \times 1.261^n$$

$$w = \frac{319.5}{1.261^n}$$

A useful approximate formula for resistance per 1000 feet at about 20° C. is as follows;

$$r = 0.1 \times (2)^{\frac{n}{3}} \quad ((2)^{\frac{1}{3}} = 1.26; (2)^{\frac{2}{3}} = 1.59.)$$

From this it is seen that an increase of 3 in the wire number corresponds to doubling the resistance and halving the cross section and weight. Also, that an increase of 10 in the wire number increases the resistance 10 times and diminishes the cross section and weight to  $\frac{1}{10}$  their original value.

**25. WIRE STRANDS.** Wires larger than No. 0000 B. and S. are seldom made solid, but are built up of a number of small wires into a strand. The group of wires is called a "strand"; the term "wire" being reserved for the individual wires of the strand. Strands are usually built up of wires of such a size that the cross section of the metal in the strand is the same as the cross section of a solid wire having the same gauge number.

If  $n$  = number of concentric layers around one central strand,

$$\text{then } \frac{3(n^2 + n) + 1}{(2n + 1)^2} = \text{ratio of } \frac{\text{metal area}}{\text{available area}}$$

The number of wires that will strand will be  $3n(n + 1) + 1$ .

<b>TABLE 19</b>	
<b>WIRE STRANDS</b>	
Number of Strands	$\frac{\text{Metal area}}{\text{available area}}$
1	1.000
7	.778
19	.760
37	.755
61	.753
91	.752

Sec. 3

CONDUCTORS AND WIRE TABLES

26. ILLUSTRATIONS OF BARE WIRE, STRAND AND CABLE











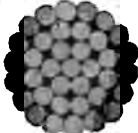



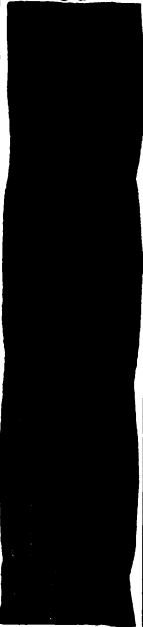



BARE WIRE		STRAND	CABLE
Full Sizes of Wire	B. & S. Gauge	Concentric Strand, 37 Wires	7 Strands, 7 Wires Each. (7 x 7)
	1		
	2		
	3		
	4		
	5		
	6		
	7		
	8		
	9		
	10		
	11		
	12		
	13		
	14		
	15		
	16		

TABLE 20

CURRENTS

FUSING EFFECTS OF CURRENTS

Table giving the diameters of wires of various materials which will be fused by a current of given strength

Current in amperes	Diameters in inches.								
	Copper	Aluminum	Platinum	German Silver	Platinoid	Iron	Tin	Tin-lead alloy	Lead
1	0.002 1	0.002 6	0.003 2	0.003 3	0.003 5	0.004 7	0.007 2	0.006 3	0.006 1
2	0.003 4	0.004 1	0.005 2	0.005 3	0.005 6	0.007 4	0.011 3	0.013 2	0.012 2
3	0.004 4	0.005 4	0.007 7	0.006 9	0.007 4	0.009 7	0.014 9	0.017 3	0.016 2
4	0.005 3	0.006 5	0.008 4	0.008 4	0.008 3	0.011 7	0.018 1	0.021 3	0.020 2
5	0.006 2	0.007 6	0.009 8	0.009 7	0.010 4	0.013 6	0.021 1	0.024 2	0.023 6
10	0.009 8	0.012	0.015 5	0.015 4	0.016 4	0.021 6	0.033 4	0.033 6	0.037 5
15	0.012 9	0.015 8	0.020 2	0.020 2	0.021 5	0.028 2	0.043 7	0.050 6	0.049 1
20	0.015 6	0.019 1	0.024 6	0.024 5	0.026 1	0.034 2	0.052 9	0.061 3	0.059 5
25	0.018 1	0.022 2	0.028 6	0.028 4	0.030 2	0.039 2	0.061 4	0.071 1	0.069
30	0.020 5	0.025	0.032 2	0.032	0.034 2	0.045	0.069 4	0.080 2	0.077 9
35	0.022 7	0.027 7	0.035 2	0.035 6	0.037 2	0.049 2	0.076 9	0.089	0.086 4
40	0.024 8	0.030 2	0.039 1	0.038 2	0.041 4	0.054 5	0.084	0.097 2	0.094 4
45	0.026 2	0.032 2	0.042 2	0.042	0.044 2	0.058 9	0.090 9	0.105 2	0.102 1
50	0.028 2	0.035 2	0.045 4	0.045	0.048	0.063 2	0.097 5	0.112 9	0.109 5
60	0.032 5	0.039 7	0.051 2	0.050 9	0.054 2	0.071 4	0.110 1	0.127 5	0.123 7
70	0.036	0.044	0.056 2	0.056 4	0.060 1	0.079 1	0.122	0.141 2	0.137 1
80	0.039 4	0.048 1	0.062 1	0.061 6	0.065 7	0.086 4	0.133 4	0.154 4	0.149 2
90	0.042 6	0.052	0.067 2	0.066 7	0.071 1	0.092 5	0.144 2	0.167 1	0.162 1
100	0.045 7	0.055 2	0.072	0.071 5	0.076 2	0.100 2	0.154 2	0.179 2	0.173 2
120	0.051 6	0.063	0.081 4	0.080 2	0.086 1	0.112 2	0.174 2	0.202 4	0.196 4
140	0.057 2	0.069 2	0.090 2	0.089 5	0.095 4	0.125 5	0.193 7	0.224 2	0.217 6
160	0.062 5	0.076 2	0.098 2	0.097 2	0.104 2	0.137 2	0.211 2	0.245 2	0.237 2
180	0.067 6	0.082 6	0.106 6	0.105 2	0.112 2	0.148 4	0.229 1	0.265 2	0.257 2
200	0.072 5	0.088 5	0.114 4	0.113 5	0.121	0.159 2	0.245 7	0.284 5	0.276
225	0.078 4	0.095 5	0.123 7	0.122 2	0.130 2	0.172 2	0.265 2	0.307 7	0.298 6
250	0.084 1	0.102 2	0.132 7	0.131 7	0.140 4	0.184 2	0.285 1	0.330 1	0.320 2
275	0.089 7	0.109 5	0.141 4	0.140 4	0.149 7	0.196 2	0.303 2	0.351 2	0.341 7
300	0.095	0.116 1	0.149 2	0.148 7	0.158 6	0.208 6	0.322	0.372 2	0.361 7



### Sec. 3 CONDUCTORS AND WIRE TABLES

#### 27. HEATING EFFECTS OF CURRENT.

If a continuous current of electricity flows through any conductor, a certain definite portion of the electrical energy supplied to the conductor will be required to overcome its resistance and transmit the current between any two points in the conductor. This energy of transmission, as it is called, is never lost, but is transformed into heat energy. Heat will be developed whenever any electric current flows through any conductor, or part of conductor, the amount of heat being directly proportional to the resistance of the conductor and to the square of the current flowing. The amount of heat measured in calories will equal

$$H = 0.24 I^2 R t$$

Where H represents calories of heat produced

I " current in amperes  
 R " resistance of conductor in ohms,  
 t " time in seconds that the current flows.

If heat be developed in the conductor faster than it can be dissipated from the surface by radiation and convection the temperature will rise. The allowable safe temperature rise is one of the limiting features of the current carrying capacity of any conductor. Since the rate at which heat will be dissipated from any conductor will depend upon many conditions, such as its size and structure, the kind and amount of insulation, if any, and its location with respect to other bodies, it is not possible to give any general definite rule for carrying capacity that will be true for all conditions. The following empirical formula will give approximate values for the current I flowing through a solid conductor, or through each conductor of a multiple conductor cable which will cause a rise in temperature of t degrees C.

$$I = C \sqrt{t \frac{d^2}{K}}$$

In this, d represents the diameter of the bare wire or strand in inches, K is the resistance per mil-foot of the wire at allowable elevated temperature t taken from the curves given in Fig. 77 and C is a constant having the following values for different conditions.

TABLE 21		
Location and Kind of Conductor	Values of Constant C in Expression of $C \sqrt{t \frac{d^2}{K}}$	
	Solid Conductor	Stranded Conductor
Bare overhead wires out of doors. . . . .	1250	1100
Bare wires in doors, exposed. . . . .	660	610
Single conductor rubber covered cable in still air. . . . .	530	490

The heat radiating surface of any conductor varies as the diameter of the conductor, while the current carrying capacity, depending on the number of circular mils, will vary as the square of the diameter. In consequence, the current density in large conductors will be less

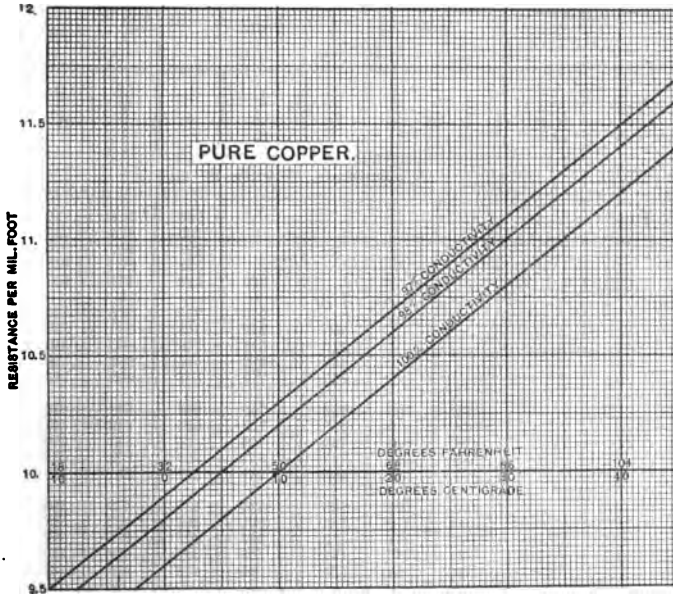

Fig. 77.—Resistance per Mil-Foot of Pure Copper at Various Temperatures and Conductivities. Values of K in expression  $C \sqrt{t \frac{d^2}{K}}$

than in small conductors for an equal temperature rise. It has been found impracticable on this account to use insulated conductors larger than 2,000,000 c. m., except in special cases.

**TABLE 22**  
**HEATING EFFECTS OF CURRENTS**  
 Bare copper in still air

Amperes.	Rise in temperature, degrees Centigrade.							
	10°		20°		40°		80°	
	Bright.	Black.	Bright.	Black.	Bright.	Black.	Bright.	Black.
	Diameters of wires in mils.							
1 000	..	..	..	..	..	968	911	750
950	..	..	..	..	..	930	878	723
900	..	..	..	..	..	893	844	695
850	..	..	..	..	..	858	809	646
800	..	..	..	..	1 000	823	771	638
750	..	..	..	..	950	785	734	610
700	..	..	..	360	900	748	696	580
650	..	..	..	910	850	708	660	550
600	..	..	..	858	800	668	621	518
575	..	..	..	833	775	648	603	503
550	..	995	800	808	750	628	583	483
525	..	978	948	780	725	607	563	461
500	..	960	913	751	700	584	543	455
475	..	925	880	723	675	563	523	439
450	..	895	848	696	648	541	501	421
425	..	860	808	669	620	520	479	406
400	1 000	820	770	641	592	498	457	387
375	950	783	731	612	564	475	435	369
350	900	745	690	581	536	452	413	350
325	850	708	654	550	506	428	390	331
300	800	668	615	519	475	403	366	312
275	750	628	575	487	444	377	341	292
250	696	586	534	453	412	351	317	272
225	642	545	494	419	379	323	291	252
200	586	500	453	384	345	296	265	229
175	530	454	406	349	310	266	239	206
150	470	404	360	311	274	226	210	194
125	408	352	308	270	235	206	182	161
100	343	300	258	226	195	170	150	135
90	315	272	237	208	178	158	137	123
80	286	246	214	196	161	143	124	112
70	259	220	190	170	143	127	110	100
60	226	194	167	150	125	112	97	87
50	191	167	142	130	106	95	82	74
40	156	140	117	108	86	78	63	61
30	120	111	90	85	66	60	54	48
20	82	76	63	60	45	44	40	36
10	40	38	37	35	30	28	26	24

**TABLE 23**  
**HEATING EFFECTS OF CURRENTS**  
 Bare copper suspended outdoors

Amperes.	Rise in temperature, degrees Centigrade.							
	5°		10°		20°		40°	
	Bright.	Black.	Bright.	Black.	Bright.	Black.	Bright.	Black.
Diameters of wires in mils.								
1 000	..	..	962	982	771	745	620	594
950	..	..	928	957	744	720	595	572
900	..	..	894	925	715	692	574	552
850	..	..	868	893	689	665	550	530
800	..	..	839	810	672	649	537	512
750	..	975	804	775	643	620	515	495
700	963	933	767	739	613	591	491	472
650	916	889	729	703	582	561	467	449
600	869	837	690	665	554	532	442	426
575	845	813	671	647	538	517	429	414
550	820	789	650	627	522	501	417	402
525	795	764	630	609	506	487	404	389
500	770	746	610	589	489	476	390	376
475	745	719	589	569	473	455	377	363
450	719	693	568	548	453	438	363	350
425	690	667	548	526	438	422	349	336
400	661	638	524	504	418	406	334	322
375	632	610	502	484	399	377	319	309
350	601	581	478	462	380	360	304	295
325	571	552	453	439	362	342	289	279
300	540	522	428	415	342	326	273	264
275	509	492	404	392	321	309	257	249
250	477	460	378	367	300	290	240	232
225	445	430	351	343	280	270	223	215
200	410	399	324	316	259	250	205	198
175	373	365	296	289	235	227	186	180
150	334	329	267	258	211	202	160	161
125	295	290	235	226	185	177	145	144
100	254	248	202	193	157	152	123	120
90	236	230	186	178	145	140	114	111
80	216	212	171	164	132	128	104	102
70	198	192	155	150	120	116	94	91
60	177	170	137	132	107	104	83	80
50	155	147	119	115	92	87	72	70
40	130	124	100	96	77	73	62	59
30	104	100	78	75	61	58	50	45
20	73	70	54	53	43	40	34	30
10	40	38	27	26	20	18	16	14

**TABLE 24**  
**CURRENT CARRYING CAPACITY OF COPPER WIRE**  
**1913 National Electrical Code**

B. & S. Gauge	Amperes		Circular Mils.
	Table A Rubber Insulation	Table B Other Insulations	
18	3	5	1,624
16	6	10	2,583
14	15	20	4,107
12	20	25	6,530
10	25	30	10,380
8	35	50	16,510
6	50	70	26,250
5	55	80	33,100
4	70	90	41,740
3	80	100	52,630
2	90	125	66,370
1	100	150	83,690
0	125	200	105,500
00	150	225	133,100
000	175	275	167,800
0000	225	325	211,600
..	200	300	200,000
..	275	400	300,000
..	325	500	400,000
..	400	600	500,000
..	450	680	600,000
..	500	760	700,000
..	550	840	800,000
..	600	920	900,000
..	650	1000	1,000,000
..	690	1080	1,100,000
..	730	1160	1,200,000
..	770	1220	1,300,000
..	810	1290	1,400,000
..	850	1360	1,500,000
..	890	1430	1,600,000
..	930	1490	1,700,000
..	970	1560	1,800,000
..	1010	1610	1,900,000
..	1050	1670	2,000,000

The current carrying capacity for other materials may be found by multiplying the current for the same gauge or circular mil size copper by the square root of the ratio of the conductivity of the material to the conductivity of copper or by the square root of the ratio of the specific resistance of copper to the specific resistance of the material:

**Symbols:**

- C = Conductivity of copper
- C' = Conductivity of material, the current carrying capacity of which is desired
- $\rho$  = Specific resistance of copper
- $\rho'$  = Specific resistance of other material
- I = Current carrying capacity of copper
- I' = Current carrying capacity of other material.

Then

$$I' = I \sqrt{\frac{C'}{C}} = I \sqrt{\frac{\rho}{\rho'}}$$

**Problem:**

Find the current carrying capacity of a No. 0, 40% copper clad solid wire and that of a No. 0, 61% aluminum solid wire, assuming the current carrying capacity of No. 0 copper to be 200 amperes.

Copper Clad.

$$C = 1.00$$

$$C' = 0.4$$

$$\text{Then } I' = 200 \sqrt{\frac{0.4}{1}} = 200 \times 0.632 = 126.4 \text{ amperes.}$$

For aluminum:

Resistance of copper from Table 35 = 0.09811

Resistance of aluminum from Table 35 = 0.1608

$$I' = 200 \sqrt{\frac{0.09811}{0.1608}} = 200 \times 0.78 = 156 \text{ amperes.}$$

**Note:** The above formulae apply to direct current problems. When alternating current is used, it is necessary to correct the resistances of all cables for skin effect.

**28. EFFECTIVE RESISTANCE—SKIN EFFECT.** The effective resistance of a circuit to an alternating current depends on the shape of the circuit; the specific resistance, permeability, cross section and shape of the conductor, and the frequency of the current. The current density over the cross section of the conductor is a minimum at the center, increasing to a maximum at the periphery; in a solid conductor of large cross section the current is confined almost entirely to an outer shell or "skin." "The Skin Effect Factor" is the number by which the resistance of the circuit to a continuous current must be multiplied to give the effective resistance to an alter-

### Sec. 3 CONDUCTORS AND WIRE TABLES

nating current. The following formulae and table give the "Skin Effect Factor" for a straight wire of circular cross section, the return wire of the circuit being assumed sufficiently remote to be without effect, which is practically the case in an aerial transmission line.

Let

- R = resistance of wire in ohms to a continuous current
- R' = effective resistance of wire in ohms to an alternating current
- f = cycles per second
- A = cross section of wire in circular mils
- $\mu$  = permeability of wire in C. G. S. units
- t = temperature in ° C.
- a = temperature coefficient per ° C.
- C = percentage conductivity of wire referred to Matthiessen's copper standard at 0° C.

Then

$$\frac{R'}{R} = \text{function of } \frac{(f \mu CA)}{(1+at)}$$

This function is a complex one; however, for

$$\frac{f \mu CA}{1+at} > 3 \times 10^{10}$$

the approximate formula  $\frac{R'}{R} = 10^{-5} \sqrt{\frac{f \mu CA}{1+at}} + 0.28$

is sufficiently accurate for all practicable purposes.

**Problem:**

Find the approximate resistance of 500,000 cir. mils stranded copper cable carrying a 60 cycle current.

$$f A = 500,000 \times 60 = 30,000,000$$

$$\text{Factor from Table 25} = 1.025$$

$$\text{Resistance from Table 36} = 0.02116$$

$$\text{Effective resistance} = 0.02116 \times 1.025 = 0.02169$$

**Problem:**

Find the approximate effective resistance of No. 0000 B. & S. 40% copper clad solid wire carrying a 60 cycle current of 80 amperes.

Find the percent increase in resistance from Fig. 79 = 22.8%

Find the resistance of No. 0000 copper clad from Table 35 = 0.125

$$\text{Effective resistance} = 0.125 \times 1.228 = 0.1535$$

TABLE 25				
SKIN EFFECT FACTORS AT 20° C. FOR STRAIGHT WIRES HAVING CIRCULAR CROSS SECTION				
Product of Circular Mills by Cycles per Second. $f \times A$	Factor* for Iron Wire. C = 17 $\mu = 150$	Product of Circular Mills by Cycles per Second. $f \times A$	Factor for	
			Copper Wire. C = 100 $\mu = 1$	Aluminum Wire. C = 62 $\mu = 1$
500,000	1.000	5,000,000	1.000	1.000
1,000,000	1.015	10,000,000	1.000	1.000
2,000,000	1.030	20,000,000	1.003	1.000
3,000,000	1.144	30,000,000	1.025	1.006
4,000,000	1.234	40,000,000	1.045	1.015
5,000,000	1.332	50,000,000	1.070	1.026
6,000,000	1.435	60,000,000	1.096	1.040
7,000,000	1.535	70,000,000	1.126	1.053
8,000,000	1.628	80,000,000	1.158	1.069
9,000,000	1.714	90,000,000	1.195	1.085
10,000,000	1.795	100,000,000	1.230	1.104
12,500,000	1.974	125,000,000	1.332	1.151
15,000,000	2.14	150,000,000	1.433	1.206
17,500,000	2.29	175,000,000	1.530	1.266
20,000,000	2.42	200,000,000	1.622	1.330
25,000,000	2.63	250,000,000	1.790	1.455
30,000,000	2.90	300,000,000	1.967	1.575
35,000,000	3.11	350,000,000	2.07	1.686
40,000,000	3.31	400,000,000	2.20	1.787
45,000,000	3.49	450,000,000	2.31	1.879
50,000,000	3.67	500,000,000	2.42	1.965
55,000,000	3.83	550,000,000	2.58	2.05
60,000,000	3.99	600,000,000	2.63	2.13

\* This corresponds to E. B. B. telegraph wire for telephone currents. The permeability  $\mu$  is not constant, but varies with the current density, therefore the table for iron wire should be used with very great care and only as an approximation.

There also is a difference of opinion concerning the factors controlling skin effect in copper and aluminum wires. These tables also should be used with great care, especially for cables larger than 1,000,000 cir. mils.



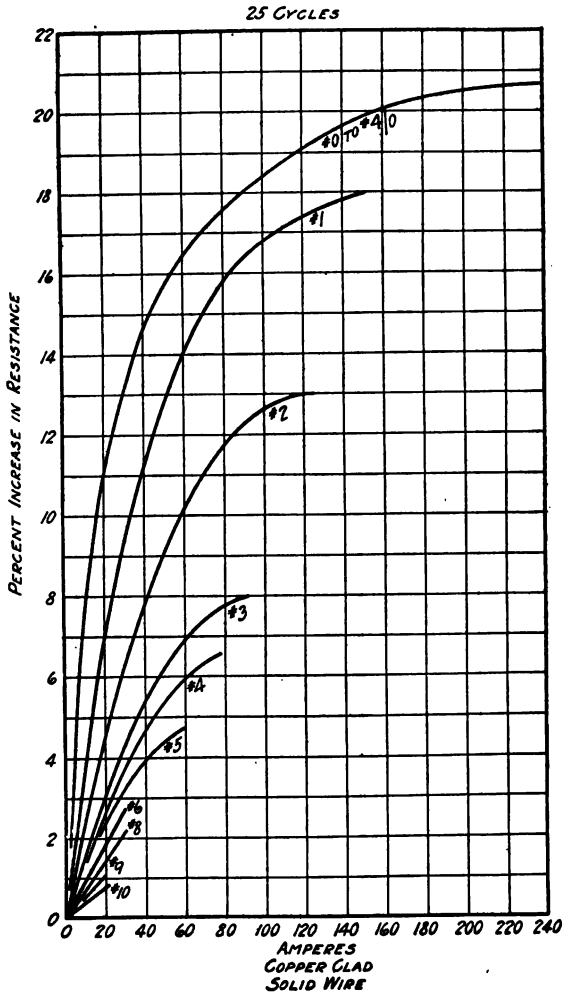

FIG. 78.

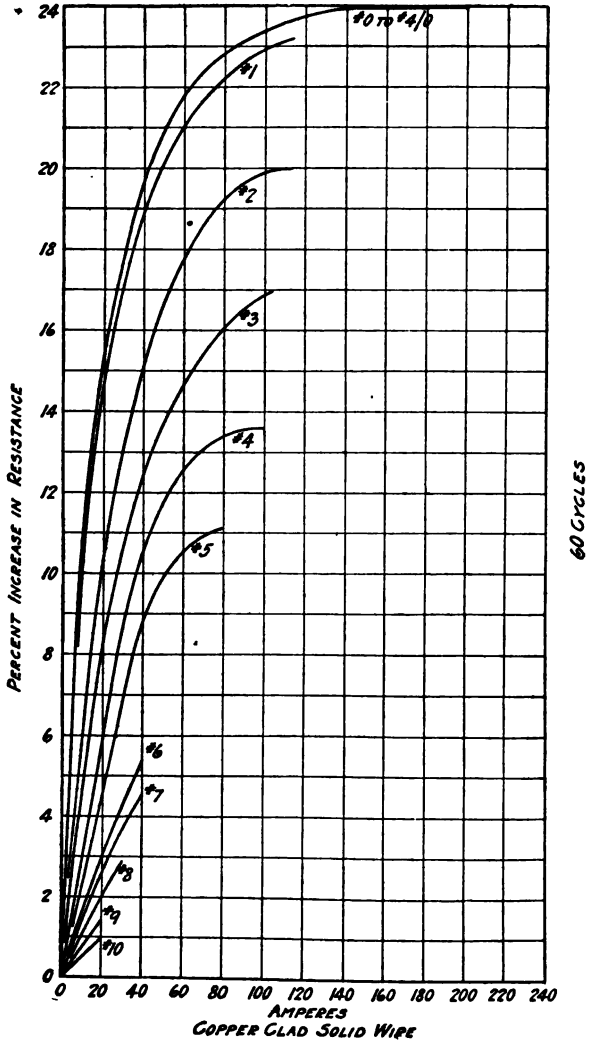

FIG. 79.

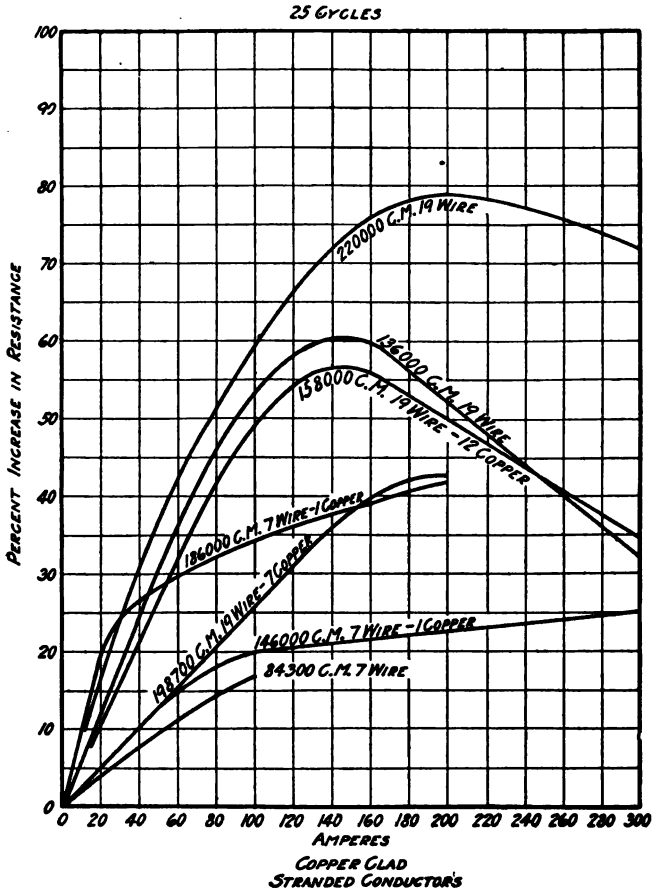

FIG. 80.

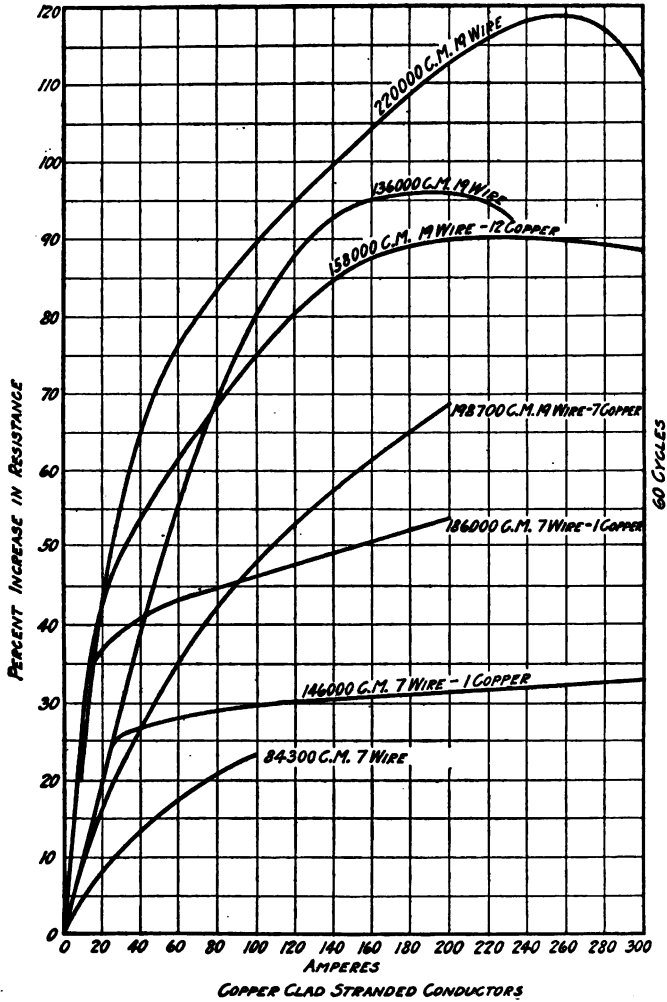

Fig. 81

### Sec. 3 CONDUCTORS AND WIRE TABLES

#### 29. STEEL STRAND FOR GUYING POLES AND FOR SPAN WIRE. Galvanized or Extra Galvanized.



FIG. 82. Seven steel wires twisted into a single strand.

<b>TABLE 26</b>			
<b>STANDARD STEEL STRAND</b>			
<b>Galvanized or Extra Galvanized</b>			
Area in Sq. Inches	Diameter in Inches	Approximate Weight per 1000 Feet Pounds	Approximate Strength in Pounds
.1443	$\frac{1}{8}$ $\frac{1}{8}$ $\frac{1}{8}$ $\frac{1}{8}$ $\frac{1}{8}$ $\frac{1}{8}$ $\frac{1}{8}$	510	8500.
.1209		415	6500.
.0798		295	5000.
.0639		210	3800.
.0382		125	2300.
.0218		75	1400.
.0092		32	500.

This strand is used chiefly for guying poles and for supporting trolley wire.

For overhead catenary construction suspending trolley wire, the special grades of strand are considered preferable because they possess greater strength and toughness.

#### 30. EXTRA GALVANIZED SPECIAL STRANDS.



FIG. 83. Seven steel wires twisted into a single strand.

Three special grades of Extra Galvanized Strand are manufactured.

Extra Galvanized Siemens-Martin Strand.

Extra Galvanized High Strength (crucible steel) Strand.

Extra Galvanized Extra High Strength (plow steel) Strand.

Strands of all three grades are composed of seven wires each, and are galvanized.

TABLE 27  
EXTRA GALVANIZED SPECIAL STRANDS

Area in Sq. Inches	EXTRA GALVANIZED SIEMENS-MARTIN STRAND				EXTRA GALVANIZED HIGH STRENGTH STRAND				EXTRA GALVANIZED HIGH STRENGTH STRAND			
	Diameter in Inches	Actual Breaking Strength in Pounds	Elastic Limit Per Cent.	Elongation in 24 Inches Per Cent.	Diameter in Inches	Actual Breaking Strength in Pounds	Elastic Limit Per Cent.	Elongation in 24 Inches Per Cent.	Diameter in Inches	Actual Breaking Strength in Pounds	Elastic Limit Per Cent.	Elongation in 24 Inches Per Cent.
.2906	1/4	19,000	50	10.0	1/4	25,000	55	6	1/4	42,500	60	4
.1443	1/4	11,000	50	10.0	1/4	16,000	55	6	1/4	27,000	60	4
.1209	5/16	9,000	50	10.0	5/16	15,000	55	6	5/16	22,500	60	4
.0798	1/2	6,800	50	10.0	1/2	11,500	55	6	1/2	17,250	60	4
.0639	5/8	4,850	50	10.0	5/8	8,100	55	6	5/8	12,100	60	4
.046	3/4	4,350	50	10.0	3/4	7,300	55	6	3/4	10,000	60	4
.0352	7/8	3,000	50	10.0	7/8	5,100	55	6	7/8	7,600	60	4
.0218	1	2,000	50	10.0	1	3,300	55	6	1	4,900	60	4
.0092	1 1/2	900	50	10.0	1 1/2	1,500	55	6	1 1/2	2,250	60	4
.0639	Special 1 1/2	6,000										

**TABLE 28**  
**PROPERTIES OF SPECIAL GRADES EXTRA GALVANIZED SPECIAL STRANDS**

Area Sq. Inches	Diameter of Strand, Inches	Number of Wires in Strand	Strength S. M. Strand Tons	Strength Cubic Strand Tons	Strength Plow Strand Tons	Approximate Weight per Foot Pounds
1.346	1½	61	55	91.5	121	4.75
1.093	1½	61	45.5	76	100	3.95
.942	1½	37	38	63.5	35	3.30
.753	1½	37	32.5	54	72	2.62
.697	1	37	25.5	43.7	60	2.25
.457	¾	19	19	32	45	1.70
.356	¾	19	14.2	23.7	35	1.25
.2356	¾	19	10	16.5	23.5	.81

**TABLE 29**  
**BREAKING STRENGTH OF WIRE. SOLID**  
**Total Pounds Pull Required to Break Wire**

GAUGE B. & S.	COPPER		Aluminum	Copper clad	IRON		GAUGE B. W. G.
	Hard Drawn	Soft Drawn			E. B.	E. B. B.	
0000	8,260	5,330	3,000	10,000	..	..	..
0000	6,550	4,330	2,900	8,300	..	..	..
00	5,440	3,240	2,850	6,850	..	..	..
0	4,530	2,650	1,845	5,700	4,634	4,138	0
1	3,630	2,100	1,510	4,300	3,699	3,233	1
2	2,970	1,670	1,200	4,000	3,234	2,868	2
3	2,380	1,323	971	3,500	2,628	2,400	3
4	1,900	1,050	787	2,900	2,271	2,028	4
5	1,500	884	639	2,500	1,940	1,783	5
6	1,200	700	516	1,800	1,652	1,475	6
7	1,050	568	422	1,450	1,396	1,158	7
8	843	441	340	1,200	1,092	975	8
9	678	350	264	975	879	765	9
10	546	277	215	800	722	645	10
11	433	230	172	680	577	515	11
12	343	174	143	510	476	435	12
13	277	138	116	410	347	310	13
14	219	110	93	320	277	247	14
15	174	87	75	..	207	185	15
16	138	68.9	60	..	171	152	16
17	109.5	54.7	48	..	135	120	17
18	86.7	43.4	38	..	96	86	18
19	68.5	34.5	30	..	..	..	19
20	54.7	27.5	24	..	..	..	20



**TABLE 30**  
**BREAKING STRENGTH OF WIRE, STRANDED**  
**Total Pounds Pull Required to Break Wire**

Area in Cir. Mils.	COPPER		Aluminum	Copper clad	Area in Cir. Mils.
	Hard Drawn	Soft Drawn			
	500,000	24,605			
450,000	22,000	11,400	24,800	333,900	
400,000	19,370	10,120	8,118	..	..
350,000	16,950	8,860	7,210	23,230	366,610
300,000	14,540	7,600	6,180	20,520	311,300
250,000	12,075	6,225	4,762	15,680	246,920
0000	8,260	5,320	4,125	13,680	197,680
000	6,560	4,220	3,372	11,120	157,840
00	5,440	3,340	2,710	9,140	146,160
0	4,530	2,650	2,205	7,560	114,690
1	3,680	2,100	1,686	5,940	72,830
2	2,970	1,670	1,366	..	..
3	2,380	1,323	1,120	3,220	45,930
4	1,900	1,040	917	..	..
5	1,500	864	741	..	..
6	1,300	700	598	..	..
7	..	..	481	..	..
8	..	..	389	..	..

TABLE 31 DIAMETERS OF WIRES. SOLID Diameters of Wires in Inches									
GAUGE B. & S.	COPPER		ALUMINUM		COPPER CLAD		IRON		GAUGE B.W.G.
	Bare	T.B.W.*	Bare	T.B.W.	Bare	T.B.W.	Bare	T.B.W.	
0000	.460	.660	.460	.635	.460	.660	..	..	..
000	.4696	.695	.4696	.696	.4696	.695	..	..	..
00	.4648	.650	.4648	.660	.4648	.650	..	..	..
0	.325	.505	.325	.525	.325	.505	.34	..	0
1	.2883	.445	.2883	.450	.2883	.445	.286	..	1
2	.2576	.400	.2576	.415	.2576	.400	.254	..	2
3	.2294	.371	.2294	.380	.2294	.371	.229	..	3
4	.2043	.346	.2043	.350	.2043	.346	.203	..	4
5	.1819	.323	.1819	.325	.1819	.323	.182	..	5
6	.162	.303	.162	.310	.162	.303	.163	..	6
7	.1443	.285	.1443	.290	.1443	.285	.140	..	7
8	.1285	.264	.1285	.255	.1285	.264	.125	..	8
9	.1144	.249	.1144	.240	.1144	.249	.113	..	9
10	.1019	.221	.1019	.227	.1019	.221	.101	..	10
11	.9007	..	.9007	.215	.9007	..	.100	..	11
12	.8008	.200	.8008	.205	.8008	.200	.100	..	12
13	.7172	..	.7172	.197	.7172	..	.095	..	13
14	.6441	.182	.6441	.185	.6441	.182	.083	..	14
15	.5771	..	.5771	..	..	..	.072	..	15
16	.5168	.169	.5168	..	..	..	.065	..	16
17	.4633	..	.4633	..	..	..	.058	..	17
18	.4163	.158	.4163	..	..	..	.049	..	18
19	.3759	..	.3759	..	..	..	..	..	19
20	.332	..	.332	..	..	..	..	..	20

\* Triple Braid Weatherproof.

**TABLE 32**  
**DIAMETERS OF WIRES, STRANDED**  
 Diameters of Wires in Inches

Area in Cir. Mills.	COPPER		ALUMINUM		COPPER CLAD		Area in Cir. Mills.
	Bare	T. B. W.	Bare	T. B. W.	Bare	T. B. W.	
500,000	.815	1.108	.813	1.094	.81	1.108	688,640
450,000	.777	1.07	.772	1.052	.77	1.012	391,990
400,000	.728	1.02	.726	1.000			
350,000	.682	.978	.679	.970	.685	.881	368,610
300,000	.634	.930	.631	.915	.64	.825	311,800
250,000	.578	.882	.587	.861	.57	.807	246,570
0000	.528	.785	.522	.760	.51	.767	197,620
000	.470	.728	.464	.695	.45	.715	157,340
00	.415	.662	.414	.651	.42	.678	140,150
0	.375	.605	.368	.600	.364	.620	114,690
1	.333	.515	.328	.475	.306	.454	71,830
2	.292	.440	.293	.468			
3	.260	.408	.260	.400	.243	.390	45,900
4	.232	.379	.232	.375			
5	.206	.351	.206	.375			
6	.184	.327	.184	.325			
7	.164	.300	.164	.300			
8	.145	.290	.146	.296			

TABLE 33  
WEIGHTS OF WIRES. SOLID  
Weights of Wires in Pounds Per 1000 Feet

GAUGE B. & S.	COPPER		ALUMINUM		COPPER CLAD		IRON		GAUGE B.W.G.
	Bare	T.B.W.	Bare	T.B.W.	Bare	T.B.W.	Bare	T.B.W.	
0000	641	767	193	289	695	712	...	...	...
000	508	629	133	234	471	593	...	...	...
00	403	502	121	171	374	478	...	...	...
0	320	407	96.2	138	297	335	315	...	0
1	253	316	76.3	112	235	298	244	...	1
2	201	260	60.5	94	166	245	215	...	2
3	159	199	48.0	78	142	188	182	...	3
4	126	164	38.1	64	117	155	155	...	4
5	100	135	30.1	52.2	92.9	127	131	...	5
6	79.4	112	23.9	43.5	73.7	106	112	...	6
7	63.	83.	19.	36.4	58.5	87	87	...	7
8	50.	75	15.1	31.	46.4	71	74	...	8
9	39.6	62	11.9	25.4	36.8	59	60	...	9
10	31.4	53	9.45	21.5	29.2	51	49	...	10
11	24.9	..	7.50	18.8	23.1	..	23	...	11
12	19.7	35	5.95	16.5	18.3	34	22	...	12
13	15.7	..	4.72	14.5	14.6	..	25	...	13
14	12.4	25	3.74	12.8	11.8	24	19	...	14
15	9.9	..	2.97	..	..	..	14	...	15
16	7.8	20	2.35	..	..	..	11	...	16
17	6.2	..	1.87	..	..	..	..	...	17
18	4.9	16	1.43	..	..	..	..	...	18
19	3.9	..	1.13	..	..	..	6.5	...	19
20	3.1	..	.94	..	..	..	..	...	20

**TABLE 34**  
**WEIGHTS OF WIRES, STRANDED**  
**Weights of Wires in Pounds Per 1000 Feet**

Area in Cir. Mils.	COPPER		ALUMINUM		COPPER CLAD		Area in Cir. Mils.
	Bare	T. B. W.	Bare	T. B. W.	Bare	T. B. W.	
500,000	1,554	1,894	460	692	1,484	1,825	498,640
450,000	1,415	1,724	414	619	1,372	1,450	392,990
400,000	1,242	1,553	368	548	1,091	1,350	345,610
350,000	1,087	1,345	322	477	925	1,160	311,300
300,000	945	1,174	276	411	785	950	246,220
250,000	775	985	230	350	539	770	197,680
0000	658	800	195	300	468	600	157,240
000	570	653	155	245	430	540	145,150
00	414	522	123	178	340	440	114,690
0	328	424	97	144	215	215	75,830
1	259	323	77	98	..	..	..
2	206	270	61	88	..	..	..
3	164	206	48.5	52.5	..	..	..
4	133	170	38.5	47.0	..	..	..
5	103	140	30.4	52.4	..	..	..
6	81	115	24.1	43.7	..	..	..
7	..	..	19.2	34.6	..	..	..
8	..	..	15.2	31.1	..	..	..

TABLE 35 RESISTANCE, SOLID WIRE Resistance of Wires at 20° C. in Ohms Per 1000 Feet									
GAUGE B. & S.	COPPER		ALUMINUM		COPPER CLAD		IRON WIRE		GAUGE E.W.G.
	100%	61%	30%	40%	B.B.	E.B.B.			
0000									
000	.04833	.0801	.168	.125	..	..	..	..	..
00	.06170	.1013	.210	.158	..	..	..	..	..
	.07750	.1374	.268	.199	..	..	..	..	..
0	.09811	.1608	.335	.251	.639	.538	.639	.538	0
1	.1237	.2029	.427	.320	.83	.691	.83	.691	1
2	.1500	.2458	.535	.401	.916	.771	.916	.771	2
3	.187	.3023	.677	.508	1.104	.928	1.104	.928	3
4	.2400	.4027	.854	.649	1.310	1.082	1.310	1.082	4
5	.3128	.5125	1.06	.866	1.530	1.283	1.530	1.283	5
6	.3944	.6470	1.35	1.01	1.797	1.510	1.797	1.510	6
7	.4973	.8152	1.71	1.29	2.29	1.921	2.29	1.921	7
8	.6271	1.028	2.17	1.62	2.73	2.322	2.73	2.322	8
9	.7908	1.296	2.73	2.05	3.28	2.897	3.28	2.897	9
10	.9972	1.634	3.43	2.56	4.11	3.452	4.11	3.452	10
11	1.257	2.061	4.31	3.22	5.15	4.235	5.15	4.235	11
12	1.586	2.699	5.43	4.06	6.24	5.260	6.24	5.260	12
13	1.999	3.277	..	..	8.56	7.175	8.56	7.175	13
14	2.521	4.132	..	..	10.70	8.79	10.70	8.79	14
15	3.179	5.210	..	..	14.31	12.01	14.31	12.01	15
16	4.009	6.57	..	..	17.60	14.60	17.60	14.60	16
17	5.055	8.235	..	..	..	..	..	..	17
18	6.374	10.447	..	..	..	..	..	..	18
19	8.033	13.764	..	..	..	..	..	..	19
20	10.14	16.612	..	..	..	..	..	..	20

**TABLE 36**  
**RESISTANCE. STRANDED WIRE**  
 Resistance of Wires at 20° C. in Ohms Per 1000 Feet

Area in Cir. Mils.	COPPER	ALUMINUM	COPPER CLAD		Area in Cir. Mils.
	100%	61%	30%	40%	
500,000	.02116	.03394	.069	.082	498,640
450,000	.02249	.03772			
400,000	.02548	.04243	.068	.066	388,990
350,000	.03026	.04849	.097	.073	346,610
300,000	.03531	.05455	.110	.083	311,900
250,000	.04233	.06790	.139	.105	246,970
0000	.04997	.08010	.175	.131	197,680
000	.06293	.1012	.220	.165	157,240
00	.07935	.1274	.288	.178	145,150
0	.10907	.1608	.390	.226	114,690
1	.13517	.2029			
2	.15725	.2358	.474	.355	72,830
3	.19837	.3223			
4	.25000	.4087	.75	.662	45,930
5	.31395	.5125			
6	.39767	.6470			
7	.50213	.8152			
8	.63666	1.023			

TABLE 37  
SELF INDUCTION

Millichenes per 1000 Feet of Conductor (For One Wire)

SOLID CONDUCTORS

SIZE OF WIRE—B. & S. GAUGE

Interaxial Distance, Inches	SIZE OF WIRE—B. & S. GAUGE																			
	0000	000	00	0	1	2	3	4	5	6	7	8	9	10	11	12	13	14	15	
3/4	..0625	..0696	..0778	..0874	..0984	..1105	..1236	..1377	..1528	..1688	..1856	..2032	..2216	..2408	..2608	..2816	..3032	..3256	..3488	..3728
1/2	..0671	..0743	..0825	..0921	..1031	..1146	..1276	..1421	..1581	..1746	..1926	..2111	..2301	..2506	..2726	..2961	..3211	..3476	..3756	..4051
1/4	..0871	..0943	..1025	..1121	..1231	..1346	..1476	..1621	..1781	..1946	..2126	..2311	..2501	..2706	..2926	..3161	..3411	..3676	..3956	..4251
1	..1046	..1117	..1199	..1295	..1405	..1520	..1650	..1795	..1955	..2130	..2320	..2525	..2745	..2980	..3230	..3495	..3775	..4070	..4380	..4705
2	..1467	..1538	..1620	..1726	..1846	..1981	..2131	..2296	..2476	..2671	..2881	..3106	..3346	..3601	..3871	..4156	..4456	..4771	..5101	..5446
3	..1715	..1786	..1868	..1974	..2094	..2229	..2379	..2544	..2724	..2919	..3129	..3354	..3594	..3849	..4119	..4404	..4704	..5019	..5349	..5694
4	..1889	..1960	..2042	..2148	..2268	..2403	..2553	..2718	..2898	..3088	..3298	..3523	..3763	..4018	..4288	..4573	..4873	..5188	..5518	..5863
5	..2025	..2096	..2178	..2294	..2424	..2569	..2729	..2904	..3094	..3309	..3539	..3784	..4044	..4319	..4609	..4914	..5234	..5569	..5919	..6284
6	..2135	..2206	..2288	..2404	..2534	..2679	..2839	..3014	..3204	..3419	..3649	..3894	..4154	..4429	..4719	..5024	..5344	..5679	..6029	..6394
7	..2229	..2300	..2382	..2508	..2648	..2803	..2973	..3158	..3358	..3573	..3803	..4048	..4308	..4583	..4873	..5178	..5498	..5833	..6183	..6548
8	..2319	..2390	..2472	..2608	..2758	..2923	..3093	..3278	..3478	..3693	..3923	..4168	..4428	..4693	..4973	..5268	..5578	..5903	..6243	..6598
9	..2382	..2453	..2535	..2671	..2821	..2986	..3156	..3341	..3541	..3756	..3986	..4231	..4491	..4756	..5036	..5331	..5641	..5966	..6306	..6661
10	..2446	..2517	..2599	..2735	..2885	..3050	..3230	..3425	..3635	..3850	..4080	..4325	..4585	..4850	..5130	..5425	..5735	..6050	..6380	..6725
11	..2498	..2569	..2651	..2787	..2937	..3102	..3282	..3477	..3687	..3912	..4152	..4407	..4677	..4962	..5262	..5577	..5907	..6252	..6612	..6982
12	..2556	..2627	..2709	..2845	..2995	..3170	..3360	..3565	..3785	..4020	..4270	..4535	..4815	..5110	..5420	..5745	..6085	..6440	..6810	..7190
15	..2695	..2766	..2848	..2984	..3134	..3309	..3499	..3704	..3924	..4159	..4409	..4674	..4954	..5249	..5559	..5884	..6224	..6579	..6949	..7334
18	..2805	..2876	..2958	..3094	..3244	..3419	..3609	..3814	..4034	..4269	..4519	..4784	..5064	..5359	..5669	..5994	..6334	..6689	..7059	..7444
21	..2897	..2968	..3050	..3186	..3336	..3501	..3681	..3876	..4086	..4311	..4551	..4806	..5076	..5361	..5661	..5976	..6306	..6651	..7011	..7386
24	..2978	..3049	..3131	..3267	..3417	..3582	..3762	..3957	..4167	..4392	..4632	..4887	..5157	..5442	..5742	..6057	..6387	..6732	..7092	..7467
30	..3114	..3185	..3267	..3403	..3553	..3718	..3898	..4093	..4303	..4528	..4768	..5023	..5293	..5578	..5878	..6193	..6523	..6868	..7228	..7603
36	..3224	..3295	..3377	..3513	..3663	..3828	..4008	..4203	..4413	..4638	..4878	..5133	..5403	..5688	..5988	..6303	..6633	..6978	..7338	..7713



TABLE 37—Continued

SIZE OF WIRE—B. & S. GAUGE

Interaxial Distance, Inches	SIZE OF WIRE—B. & S. GAUGE																		
	0000	000	00	0	1	2	3	4	5	6	7	8	9	10	11	12	13	14	15
42	3319	3290	3460	3531	3602	3673	3743	3813	3884	3954	4025	4095	4165	4236	4307	4377	4448	4518	4589
48	3399	3470	3640	3711	3782	3853	3923	3994	4065	4135	4206	4276	4347	4417	4488	4559	4629	4700	4771
54	3471	3542	3712	3783	3854	3925	3995	4065	4136	4207	4278	4349	4420	4491	4562	4633	4704	4775	4846
60	3525	3606	3776	3847	3918	3989	4060	4131	4202	4273	4344	4415	4486	4557	4628	4699	4770	4841	4912
66	3593	3684	3854	3925	3996	4067	4138	4209	4280	4351	4422	4493	4564	4635	4706	4777	4848	4919	4990
72	3646	3717	3887	3958	4029	4100	4171	4242	4313	4384	4455	4526	4597	4668	4739	4810	4881	4952	5023
78	3695	3766	3936	3997	4068	4139	4210	4281	4352	4423	4494	4565	4636	4707	4778	4849	4920	4991	5062
84	3740	3811	3981	4042	4113	4184	4255	4326	4397	4468	4539	4610	4681	4752	4823	4894	4965	5036	5107
90	3782	3853	4023	4084	4155	4226	4297	4368	4439	4510	4581	4652	4723	4794	4865	4936	5007	5078	5149
96	3821	3892	4062	4123	4194	4265	4336	4407	4478	4549	4620	4691	4762	4833	4904	4975	5046	5117	5188
102	3858	3929	4099	4160	4231	4302	4373	4444	4515	4586	4657	4728	4799	4870	4941	5012	5083	5154	5225
108	3893	3964	4134	4195	4266	4337	4408	4479	4550	4621	4692	4763	4834	4905	4976	5047	5118	5189	5260
114	3926	3997	4167	4228	4299	4370	4441	4512	4583	4654	4725	4796	4867	4938	5009	5080	5151	5222	5293
120	3957	4028	4198	4259	4330	4401	4472	4543	4614	4685	4756	4827	4898	4969	5040	5111	5182	5253	5324
126	3986	4057	4227	4288	4359	4430	4501	4572	4643	4714	4785	4856	4927	4998	5069	5140	5211	5282	5353
132	4014	4085	4255	4316	4387	4458	4529	4600	4671	4742	4813	4884	4955	5026	5097	5168	5239	5310	5381
138	4041	4112	4282	4343	4414	4485	4556	4627	4698	4769	4840	4911	4982	5053	5124	5195	5266	5337	5408
144	4067	4138	4308	4369	4440	4511	4582	4653	4724	4795	4866	4937	5008	5079	5150	5221	5292	5363	5434
150	4092	4163	4333	4394	4465	4536	4607	4678	4749	4820	4891	4962	5033	5104	5175	5246	5317	5388	5459
156	4116	4187	4357	4418	4489	4560	4631	4702	4773	4844	4915	4986	5057	5128	5199	5270	5341	5412	5483
162	4139	4210	4380	4441	4512	4583	4654	4725	4796	4867	4938	5009	5080	5151	5222	5293	5364	5435	5506
168	4161	4232	4402	4463	4534	4605	4676	4747	4818	4889	4960	5031	5102	5173	5244	5315	5386	5457	5528
174	4183	4254	4424	4485	4556	4627	4698	4769	4840	4911	4982	5053	5124	5195	5266	5337	5408	5479	5550
180	4203	4274	4444	4505	4576	4647	4718	4789	4860	4931	5002	5073	5144	5215	5286	5357	5428	5499	5570

Inter-axial Distance, Inches		CIRCULAR MILS—SIZE OF CONDUCTOR—B. & S. GAUGE												
		500,000	450,000	400,000	350,000	300,000	250,000	0000	0000	000	00	0	1	2
1	.0758	.0788	.0825	.0865	.0912	.0968	.1017	.1069	.1139	.1229	.1302	.1375	.1444	.1515
2	.1179	.1209	.1246	.1286	.1333	.1389	.1438	.1490	.1550	.1620	.1723	.1796	.1865	.1936
3	.1425	.1455	.1492	.1532	.1579	.1635	.1684	.1736	.1796	.1856	.1969	.2042	.2111	.2182
4	.1601	.1631	.1668	.1708	.1755	.1811	.1860	.1912	.2002	.2072	.2145	.2218	.2287	.2358
5	.1737	.1767	.1804	.1844	.1891	.1947	.1996	.2063	.2138	.2208	.2281	.2354	.2423	.2494
6	.1847	.1877	.1914	.1954	.2001	.2057	.2106	.2178	.2248	.2318	.2381	.2464	.2533	.2604
9	.2094	.2124	.2161	.2201	.2248	.2304	.2353	.2425	.2495	.2565	.2638	.2711	.2780	.2851
12	.2268	.2298	.2335	.2375	.2422	.2478	.2527	.2599	.2669	.2739	.2812	.2885	.2954	.3025
18	.2515	.2545	.2582	.2622	.2669	.2725	.2774	.2846	.2916	.2986	.3059	.3132	.3201	.3272
24	.2690	.2720	.2757	.2797	.2844	.2900	.2949	.3021	.3091	.3161	.3234	.3307	.3376	.3447
30	.2826	.2856	.2893	.2933	.2980	.3036	.3085	.3157	.3227	.3297	.3370	.3443	.3512	.3583
36	.2936	.2966	.3003	.3043	.3090	.3146	.3195	.3267	.3337	.3407	.3480	.3553	.3622	.3693
42	.3031	.3061	.3098	.3138	.3185	.3241	.3290	.3362	.3432	.3502	.3575	.3648	.3717	.3788
48	.3111	.3141	.3178	.3218	.3265	.3321	.3370	.3442	.3512	.3582	.3655	.3728	.3797	.3868
54	.3183	.3213	.3250	.3290	.3337	.3393	.3442	.3514	.3584	.3654	.3727	.3800	.3869	.3940
60	.3247	.3277	.3314	.3354	.3401	.3457	.3506	.3578	.3648	.3718	.3791	.3864	.3933	.4004
72	.3358	.3388	.3425	.3465	.3512	.3568	.3617	.3689	.3759	.3829	.3902	.3975	.4044	.4115
84	.3452	.3482	.3519	.3559	.3606	.3662	.3711	.3783	.3853	.3923	.3996	.4069	.4138	.4209
96	.3533	.3563	.3600	.3648	.3697	.3753	.3802	.3874	.3944	.4014	.4087	.4158	.4229	.4300
108	.3605	.3635	.3672	.3712	.3759	.3815	.3864	.3936	.4006	.4076	.4149	.4222	.4291	.4362
120	.3669	.3699	.3736	.3776	.3823	.3879	.3928	.4000	.4070	.4140	.4213	.4286	.4356	.4426
132	.3726	.3756	.3793	.3833	.3880	.3936	.3985	.4057	.4127	.4197	.4270	.4343	.4412	.4483
144	.3779	.3809	.3846	.3886	.3933	.3989	.4038	.4110	.4180	.4250	.4323	.4396	.4465	.4536
156	.3823	.3853	.3890	.3930	.3977	.4033	.4082	.4154	.4224	.4294	.4367	.4438	.4507	.4578
168	.3873	.3903	.3940	.3980	.4027	.4083	.4132	.4204	.4274	.4344	.4417	.4488	.4559	.4630
180	.3915	.3945	.3982	.4022	.4069	.4125	.4174	.4246	.4316	.4386	.4459	.4532	.4601	.4672

TABLE 39

CAPACITY SOLID CONDUCTORS

Microfarads per 1000 Feet of Circuit-Formed by Two Aerial Wires  
(2000 Feet of Wire)

Inter-axial Distance, Inches	SIZE OF WIRE—B. & S. GAUGE									
	0000	000	00	0	1	2	3	4	5	6
3/8				.14710	.03160	.01812	.01303	.01030	.00861	.00743
1/2	.05270	.02315	.01531	.01156	.00941	.00800	.00699	.00622	.00563	.00515
3/4	.01038	.00864	.00746	.00659	.00591	.00539	.00495	.00458	.00427	.00401
1	.00701	.00625	.00564	.00516	.00476	.00443	.00414	.00389	.00367	.00349
2	.00415	.00390	.00368	.00349	.00332	.00317	.00302	.00290	.00278	.00267
3	.00340	.00324	.00307	.00296	.00284	.00273	.00263	.00253	.00244	.00236
4	.00303	.00290	.00279	.00268	.00258	.00249	.00240	.00232	.00225	.00218
5	.00279	.00268	.00258	.00249	.00241	.00233	.00226	.00219	.00212	.00206
6	.00263	.00253	.00244	.00236	.00229	.00222	.00215	.00208	.00203	.00197
7	.00250	.00242	.00234	.00226	.00219	.00213	.00207	.00201	.00195	.00190
8	.00240	.00232	.00225	.00218	.00212	.00206	.00200	.00195	.00190	.00185
9	.00232	.00225	.00218	.00212	.00206	.00200	.00195	.00190	.00185	.00180
10	.00226	.00219	.00212	.00206	.00201	.00195	.00190	.00185	.00181	.00176
11	.00220	.00213	.00207	.00202	.00196	.00191	.00186	.00181	.00177	.00172
12	.00215	.00209	.00203	.00197	.00192	.00187	.00182	.00178	.00174	.00170
15	.00203	.00198	.00192	.00187	.00183	.00178	.00174	.00170	.00166	.00162
18	.00195	.00190	.00185	.00180	.00176	.00172	.00168	.00164	.00160	.00157
21	.00188	.00183	.00179	.00174	.00170	.00166	.00163	.00159	.00156	.00152
24	.00182	.00178	.00174	.00170	.00166	.00162	.00159	.00155	.00152	.00149
30	.00174	.00170	.00166	.00162	.00159	.00155	.00152	.00149	.00146	.00143
36	.00168	.00164	.00160	.00157	.00153	.00150	.00147	.00144	.00142	.00139
42	.00163	.00159	.00156	.00152	.00149	.00146	.00143	.00141	.00138	.00135
48	.00159	.00155	.00152	.00149	.00146	.00143	.00140	.00138	.00135	.00133
54	.00155	.00152	.00149	.00146	.00143	.00140	.00138	.00135	.00133	.00130
60	.00152	.00149	.00146	.00143	.00140	.00138	.00135	.00133	.00130	.00128
66	.00150	.00147	.00144	.00141	.00138	.00136	.00133	.00131	.00129	.00126
72	.00147	.00144	.00142	.00139	.00136	.00134	.00131	.00129	.00127	.00124
78	.001454	.001425	.001400	.001371	.001346	.001321	.001298	.001275	.001254	.001232
84	.001436	.001407	.001382	.001355	.001330	.001307	.001283	.001261	.001240	.001218
90	.001420	.001392	.001366	.001340	.001316	.001292	.001270	.001248	.001227	.001207
96	.001403	.001377	.001352	.001326	.001303	.001280	.001257	.001237	.001216	.001196
102	.001390	.001363	.001338	.001314	.001290	.001268	.001246	.001224	.001205	.001185
108	.001376	.001351	.001327	.001302	.001280	.001257	.001235	.001216	.001198	.001176
114	.001364	.001339	.001315	.001292	.001268	.001247	.001227	.001206	.001186	.001167
120	.001352	.001328	.001305	.001282	.001260	.001238	.001217	.001197	.001178	.001160
126	.001342	.001318	.001294	.001272	.001250	.001230	.001208	.001188	.001170	.001152
132	.001332	.001308	.001285	.001262	.001241	.001220	.001200	.001180	.001162	.001145
138	.001323	.001299	.001277	.001256	.001233	.001213	.001194	.001175	.001156	.001137
144	.001315	.001291	.001268	.001246	.001226	.001206	.001186	.001167	.001148	.001130
150	.001305	.001283	.001261	.001240	.001218	.001200	.001180	.001160	.001142	.001125
156	.001296	.001276	.001253	.001232	.001212	.001193	.001173	.001155	.001135	.001119
162	.001290	.001269	.001246	.001228	.001206	.001185	.001167	.001149	.001130	.001113
168	.001283	.001262	.001241	.001220	.001200	.001180	.001161	.001142	.001125	.001108
174	.001277	.001255	.001233	.001213	.001193	.001174	.001156	.001138	.001120	.001104
180	.001270	.001248	.001228	.001207	.001187	.001169	.001150	.001132	.001115	.001100

CONDUCTORS AND WIRE TABLES

Sec. 3

TABLE 39—Continued

CAPACITY SOLID CONDUCTORS  
Microfarads per 1000 Feet of Circuit Formed by Two Aerial Wires  
(2000 Feet of Wire)

Inter-axial Distance, Inches	SIZE OF WIRE—B. & S. GAUGE									
	7	8	9	10	11	12	13	14	15	
3/8	.00688	.00589	.00526	.00493	.00458	.00427	.00401	.00377	.00357	
1/2	.00476	.00444	.00408	.00389	.00367	.00348	.00331	.00315	.00292	
3/4	.00378	.00357	.00335	.00323	.00309	.00295	.00283	.00272	.00262	
1	.00331	.00316	.00299	.00289	.00278	.00267	.00257	.00248	.00240	
2	.00258	.00248	.00238	.00232	.00225	.00218	.00212	.00205	.00200	
3	.00229	.00222	.00213	.00206	.00202	.00197	.00192	.00187	.00182	
4	.00212	.00206	.00199	.00194	.00190	.00185	.00180	.00175	.00171	
5	.00200	.00195	.00189	.00185	.00180	.00175	.00172	.00168	.00164	
6	.00192	.00187	.00181	.00178	.00173	.00169	.00166	.00162	.00158	
7	.00185	.00181	.00175	.00172	.00168	.00164	.00161	.00157	.00154	
8	.00180	.00176	.00170	.00166	.00163	.00160	.00157	.00153	.00150	
9	.00176	.00172	.00167	.00164	.00160	.00157	.00153	.00150	.00147	
10	.00172	.00168	.00163	.00160	.00157	.00154	.00150	.00147	.00144	
11	.00169	.00165	.00160	.00157	.00154	.00151	.00148	.00145	.00142	
12	.00166	.00162	.00158	.00155	.00152	.00149	.00146	.00143	.00140	
15	.00159	.00156	.00151	.00149	.00146	.00143	.00140	.00138	.00135	
18	.00153	.00150	.00147	.00144	.00142	.00139	.00136	.00134	.00131	
21	.00149	.00146	.00143	.00141	.00138	.00135	.00133	.00130	.00128	
24	.00146	.00143	.00140	.00138	.00135	.00132	.00130	.00128	.00126	
30	.00140	.00133	.00135	.00133	.00130	.00128	.00126	.00124	.00122	
36	.00136	.00134	.00131	.00129	.00127	.00125	.00122	.00120	.00118	
42	.00133	.00131	.00128	.00126	.00124	.00122	.00120	.00118	.00116	
48	.00130	.00128	.00125	.00123	.00122	.00120	.00118	.00116	.00114	
54	.00128	.00126	.00123	.00121	.00120	.00118	.00116	.00114	.00112	
60	.00126	.00124	.00121	.00120	.00118	.00116	.00114	.00112	.00111	
66	.00124	.00122	.00120	.00118	.00116	.00114	.00113	.00110	.00109	
72	.001226	.001205	.001182	.001167	.001150	.001130	.001114	.001097	.001080	
78	.001212	.001191	.001168	.001155	.001136	.001119	.001103	.001086	.001070	
84	.001198	.001178	.001157	.001142	.001125	.001108	.001092	.001075	.001060	
90	.001187	.001168	.001145	.001132	.001115	.001098	.001083	.001065	.001050	
96	.001177	.001158	.001136	.001122	.001105	.001088	.001073	.001057	.001042	
102	.001167	.001148	.001126	.001113	.001097	.001080	.001064	.001050	.001035	
108	.001158	.001139	.001117	.001105	.001089	.001073	.001057	.001042	.001028	
114	.001150	.001131	.001110	.001098	.001081	.001065	.001050	.001035	.001020	
120	.001141	.001123	.001102	.001090	.001074	.001058	.001044	.001028	.001015	
126	.001134	.001115	.001095	.001083	.001068	.001052	.001037	.001023	.001009	
132	.001126	.001110	.001090	.001077	.001062	.001046	.001031	.001016	.001003	
138	.001120	.001104	.001083	.001071	.001055	.001040	.001025	.001011	.000998	
144	.001113	.001097	.001077	.001065	.001050	.001035	.001020	.001006	.000993	
150	.001106	.001092	.001072	.001060	.001045	.001030	.001015	.001002	.000988	
156	.001103	.001086	.001066	.001055	.001040	.001025	.001011	.000997	.000983	
162	.001097	.001080	.001061	.001050	.001035	.001020	.001006	.000993	.000980	
168	.001092	.001075	.001056	.001045	.001030	.001017	.001002	.000988	.000976	
174	.001087	.001071	.001052	.001040	.001026	.001012	.000998	.000984	.000972	
180	.001083	.001067	.001048	.001036	.001022	.001007	.000994	.000980	.000968	

**TABLE 40**  
**CAPACITY**  
 Microfarads per 1000 Feet of Circuit Formed by Two Aerial Wires (2000 Feet of Wire)

STRANDED CABLES

CIRCULAR MILS.—SIZE OF CONDUCTOR—B. & S. GAUGE

Inter-axial Distance, Inches	Circular Mils.—Size of Conductor—B. & S. Gauge															
	500,000	450,000	400,000	350,000	300,000	250,000	0000	000	00	0	1	2	3	4		
1	.02325	.01810	.01517	.01277	.0109	.00932	.00717	.00639	.00579	.00522	.00480	.00447	.00417	.00394		
2	.00624	.00590	.00564	.00534	.00505	.00474	.00450	.00420	.00395	.00374	.00352	.00333	.00319	.00304		
3	.00459	.00444	.00428	.00412	.00395	.00377	.00363	.00343	.00327	.00313	.00298	.00285	.00274	.00263		
4	.00390	.00378	.00368	.00356	.00344	.00331	.00320	.00305	.002925	.002810	.00269	.00258	.00250	.00241		
5	.00350	.00341	.00333	.00323	.00313	.00303	.00294	.00281	.00271	.002610	.002505	.002414	.00234	.00226		
6	.00324	.00315	.00309	.00301	.002925	.00286	.00275	.00264	.00255	.002467	.00237	.002290	.00223	.002157		
9	.00278	.00272	.00267	.00261	.00255	.00248	.00242	.00234	.002266	.002200	.002126	.002060	.002010	.001950		
12	.00253	.00248	.00244	.00239	.00234	.00228	.00223	.00216	.00210	.002043	.001980	.001925	.001880	.001828		
18	.00225	.00221	.00214	.00210	.00206	.00202	.001956	.001907	.001860	.001806	.001760	.001722	.001680			
24	.00209	.00205	.00203	.001996	.00196	.00192	.001884	.001832	.001795	.001748	.001700	.001660	.001626	.001588		
30	.00198	.00195	.00192	.001893	.00186	.001825	.001793	.001748	.001708	.001670	.001628	.001590	.001560	.001525		
36	.00190	.00187	.001846	.00182	.00179	.001755	.001725	.001684	.001646	.001612	.001572	.001538	.001508	.001475		
42	.00183	.001807	.001786	.00176	.001732	.00170	.001674	.001633	.001597	.001566	.001530	.001496	.001467	.001437		
48	.00178	.001757	.001736	.001712	.001686	.001656	.001628	.001593	.001560	.001528	.001493	.001460	.001434	.001410		
54	.00174	.001714	.001696	.001672	.001647	.001620	.001593	.00156	.001526	.001496	.001462	.001432	.001406	.001378		
60	.00170	.00168	.001660	.001637	.001613	.001586	.001562	.001528	.001497	.001468	.001435	.001405	.001378	.001355		
72	.00164	.00162	.00160	.00158	.00156	.00154	.00151	.00148	.00145	.001425	.001394	.001365	.001342	.001316		
84	.00159	.001573	.001556	.001537	.001516	.001493	.00147	.00144	.001413	.001388	.001358	.001333	.001310	.001285		
96	.00155	.001533	.00152	.00150	.00148	.001457	.001437	.001408	.001382	.001358	.00133	.001305	.001283	.001260		
108	.00152	.001502	.001487	.00147	.00145	.001428	.00141	.001382	.001356	.001331	.001305	.001282	.001260	.001238		
120	.00149	.001475	.00146	.001443	.001425	.001403	.001384	.001358	.001333	.001310	.001285	.001260	.001240	.001218		
132	.001466	.00145	.001437	.00142	.001402	.001382	.001358	.001338	.001314	.001292	.001268	.001244	.001218	.001202		
144	.001445	.00143	.001415	.00140	.001382	.001362	.001345	.001318	.001295	.001275	.001250	.001228	.001208	.001189		
156	.001425	.00141	.001397	.00138	.001365	.001345	.001327	.001303	.001280	.001259	.001235	.001213	.001195	.001175		
168	.001407	.001393	.00138	.001365	.001348	.001330	.001312	.001288	.001266	.001245	.001222	.001200	.001183	.001164		
180	.001380	.001377	.001365	.00135	.001333	.001315	.001297	.001275	.001253	.001233	.001210	.001190	.001170	.001152		

CONDUCTORS AND WIRE TABLES

Sec. 3

Inter-axial Distance, Inches		INDUCTIVE REACTANCE Ohms per 1000 Feet (for one wire)													SOLID CONDUCTORS 25 Cycles										
		0000	000	00	0	1	2	3	4	5	6	7	8	9	10	11	12	13	14	15					
1/2		0.00926	0.1093	0.1148	0.1259	0.1370	0.1481	0.1591	0.1702	0.1813	0.1924	0.2035	0.2146	0.2257	0.2368	0.2479	0.2590	0.2701	0.2812	0.2923	0.3034	0.3145	0.3256	0.3367	
		0.1368	0.1479	0.1590	0.1701	0.1812	0.1923	0.2034	0.2145	0.2256	0.2367	0.2478	0.2589	0.2700	0.2811	0.2922	0.3033	0.3144	0.3255	0.3366					
3/4		0.1644	0.1755	0.1866	0.1977	0.2088	0.2199	0.2310	0.2421	0.2532	0.2643	0.2754	0.2865	0.2976	0.3087	0.3198	0.3309	0.3420	0.3531	0.3642					
		0.2306	0.2417	0.2528	0.2639	0.2750	0.2861	0.2972	0.3083	0.3194	0.3305	0.3416	0.3527	0.3638	0.3749	0.3860	0.3971	0.4082	0.4193	0.4304	0.4415	0.4526	0.4637	0.4748	0.4859
1		0.2968	0.3079	0.3190	0.3301	0.3412	0.3523	0.3634	0.3745	0.3856	0.3967	0.4078	0.4189	0.4300	0.4411	0.4522	0.4633	0.4744	0.4855	0.4966					
		0.3181	0.3292	0.3403	0.3514	0.3625	0.3736	0.3847	0.3958	0.4069	0.4180	0.4291	0.4402	0.4513	0.4624	0.4735	0.4846	0.4957	0.5068	0.5179	0.5290	0.5401	0.5512	0.5623	0.5734
1 1/2		0.3353	0.3464	0.3575	0.3686	0.3797	0.3908	0.4019	0.4130	0.4241	0.4352	0.4463	0.4574	0.4685	0.4796	0.4907	0.5018	0.5129	0.5240	0.5351					
		0.3501	0.3612	0.3723	0.3834	0.3945	0.4056	0.4167	0.4278	0.4389	0.4500	0.4611	0.4722	0.4833	0.4944	0.5055	0.5166	0.5277	0.5388	0.5499	0.5610	0.5721	0.5832	0.5943	0.6054
2		0.3829	0.3940	0.4051	0.4162	0.4273	0.4384	0.4495	0.4606	0.4717	0.4828	0.4939	0.5050	0.5161	0.5272	0.5383	0.5494	0.5605	0.5716	0.5827					
		0.3742	0.3853	0.3964	0.4075	0.4186	0.4297	0.4408	0.4519	0.4630	0.4741	0.4852	0.4963	0.5074	0.5185	0.5296	0.5407	0.5518	0.5629	0.5740	0.5851	0.5962	0.6073	0.6184	0.6295
2 1/2		0.3843	0.3954	0.4065	0.4176	0.4287	0.4398	0.4509	0.4620	0.4731	0.4842	0.4953	0.5064	0.5175	0.5286	0.5397	0.5508	0.5619	0.5730	0.5841					
		0.3933	0.4044	0.4155	0.4266	0.4377	0.4488	0.4599	0.4710	0.4821	0.4932	0.5043	0.5154	0.5265	0.5376	0.5487	0.5598	0.5709	0.5820	0.5931	0.6042	0.6153	0.6264	0.6375	0.6486
3		0.4015	0.4126	0.4237	0.4348	0.4459	0.4570	0.4681	0.4792	0.4903	0.5014	0.5125	0.5236	0.5347	0.5458	0.5569	0.5680	0.5791	0.5902	0.6013					
		0.4230	0.4341	0.4452	0.4563	0.4674	0.4785	0.4896	0.5007	0.5118	0.5229	0.5340	0.5451	0.5562	0.5673	0.5784	0.5895	0.6006	0.6117	0.6228	0.6339	0.6450	0.6561	0.6672	0.6783
3 1/2		0.4403	0.4514	0.4625	0.4736	0.4847	0.4958	0.5069	0.5180	0.5291	0.5402	0.5513	0.5624	0.5735	0.5846	0.5957	0.6068	0.6179	0.6290	0.6401					
		0.4551	0.4662	0.4773	0.4884	0.4995	0.5106	0.5217	0.5328	0.5439	0.5550	0.5661	0.5772	0.5883	0.5994	0.6105	0.6216	0.6327	0.6438	0.6549	0.6660	0.6771	0.6882	0.6993	0.7104
4		0.4678	0.4789	0.4900	0.5011	0.5122	0.5233	0.5344	0.5455	0.5566	0.5677	0.5788	0.5899	0.6010	0.6121	0.6232	0.6343	0.6454	0.6565	0.6676					
		0.4832	0.5003	0.5114	0.5225	0.5336	0.5447	0.5558	0.5669	0.5780	0.5891	0.6002	0.6113	0.6224	0.6335	0.6446	0.6557	0.6668	0.6779	0.6890	0.7001	0.7112	0.7223	0.7334	0.7445
5		0.5064	0.5175	0.5286	0.5397	0.5508	0.5619	0.5730	0.5841	0.5952	0.6063	0.6174	0.6285	0.6396	0.6507	0.6618	0.6729	0.6840	0.6951	0.7062					

TABLE 41—Continued

SIZE OF WIRE—B. & S. GAUGE

Inter-axial Distance, Inches	SIZE OF WIRE—B. & S. GAUGE																		
	00/00	00/0	0	1	2	3	4	5	6	7	8	9	10	11	12	13	14	15	
42	.05214	.05325	.05436	.05547	.05658	.05769	.05880	.05991	.06102	.06213	.06324	.06435	.06546	.06657	.06768	.06879	.06990	.07101	.07212
48	.06339	.06450	.06561	.06672	.06783	.06894	.07005	.07116	.07227	.07338	.07449	.07560	.07671	.07782	.07893	.08004	.08115	.08226	.08337
54	.07452	.07563	.07674	.07785	.07896	.08007	.08118	.08229	.08340	.08451	.08562	.08673	.08784	.08895	.09006	.09117	.09228	.09339	.09450
60	.08565	.08676	.08787	.08898	.09009	.09120	.09231	.09342	.09453	.09564	.09675	.09786	.09897	.10008	.10119	.10230	.10341	.10452	.10563
66	.09678	.09789	.09900	.10011	.10122	.10233	.10344	.10455	.10566	.10677	.10788	.10899	.11010	.11121	.11232	.11343	.11454	.11565	.11676
72	.10791	.10902	.11013	.11124	.11235	.11346	.11457	.11568	.11679	.11790	.11901	.12012	.12123	.12234	.12345	.12456	.12567	.12678	.12789
78	.11904	.12015	.12126	.12237	.12348	.12459	.12570	.12681	.12792	.12903	.13014	.13125	.13236	.13347	.13458	.13569	.13680	.13791	.13902
84	.13017	.13128	.13239	.13350	.13461	.13572	.13683	.13794	.13905	.14016	.14127	.14238	.14349	.14460	.14571	.14682	.14793	.14904	.15015
90	.14130	.14241	.14352	.14463	.14574	.14685	.14796	.14907	.15018	.15129	.15240	.15351	.15462	.15573	.15684	.15795	.15906	.16017	.16128
102	.15243	.15354	.15465	.15576	.15687	.15798	.15909	.16020	.16131	.16242	.16353	.16464	.16575	.16686	.16797	.16908	.17019	.17130	.17241
108	.16356	.16467	.16578	.16689	.16800	.16911	.17022	.17133	.17244	.17355	.17466	.17577	.17688	.17799	.17910	.18021	.18132	.18243	.18354
114	.17469	.17580	.17691	.17802	.17913	.18024	.18135	.18246	.18357	.18468	.18579	.18690	.18801	.18912	.19023	.19134	.19245	.19356	.19467
120	.18582	.18693	.18804	.18915	.19026	.19137	.19248	.19359	.19470	.19581	.19692	.19803	.19914	.20025	.20136	.20247	.20358	.20469	.20580
126	.19695	.19806	.19917	.20028	.20139	.20250	.20361	.20472	.20583	.20694	.20805	.20916	.21027	.21138	.21249	.21360	.21471	.21582	.21693
132	.20808	.20919	.21030	.21141	.21252	.21363	.21474	.21585	.21696	.21807	.21918	.22029	.22140	.22251	.22362	.22473	.22584	.22695	.22806
138	.21921	.22032	.22143	.22254	.22365	.22476	.22587	.22698	.22809	.22920	.23031	.23142	.23253	.23364	.23475	.23586	.23697	.23808	.23919
144	.23034	.23145	.23256	.23367	.23478	.23589	.23700	.23811	.23922	.24033	.24144	.24255	.24366	.24477	.24588	.24699	.24810	.24921	.25032
150	.24146	.24257	.24368	.24479	.24590	.24701	.24812	.24923	.25034	.25145	.25256	.25367	.25478	.25589	.25700	.25811	.25922	.26033	.26144
156	.25259	.25370	.25481	.25592	.25703	.25814	.25925	.26036	.26147	.26258	.26369	.26480	.26591	.26702	.26813	.26924	.27035	.27146	.27257
162	.26371	.26482	.26593	.26704	.26815	.26926	.27037	.27148	.27259	.27370	.27481	.27592	.27703	.27814	.27925	.28036	.28147	.28258	.28369
168	.27484	.27595	.27706	.27817	.27928	.28039	.28150	.28261	.28372	.28483	.28594	.28705	.28816	.28927	.29038	.29149	.29260	.29371	.29482
174	.28597	.28708	.28819	.28930	.29041	.29152	.29263	.29374	.29485	.29596	.29707	.29818	.29929	.30040	.30151	.30262	.30373	.30484	.30595
180	.29710	.29821	.29932	.30043	.30154	.30265	.30376	.30487	.30598	.30709	.30820	.30931	.31042	.31153	.31264	.31375	.31486	.31597	.31708

## CONDUCTORS AND WIRE TABLES

Sec. 3

X = (0.377 L) Ohms Inter-axial Distance, Inches		TABLE 42 INDUCTIVE REACTANCE Ohms per 1000 Feet (for one wire)															SOLID CONDUCTORS 60 Cycles				
		SIZE OF WIRE—B. & S. GAUGE																			
		0000	000	0	1	2	3	4	5	6	7	8	9	10	11	12	13	14	15		
7/8	.02396	.02622	.02888	.03154	.03420	.03686	.03952	.04218	.04484	.04750	.05016	.05282	.05548	.05814	.06080	.06346	.06612	.06878	.07144		
7/16	.02394	.02620	.02886	.03152	.03418	.03684	.03950	.04216	.04482	.04748	.05014	.05280	.05546	.05812	.06078	.06344	.06610	.06876	.07142		
3/4	.02392	.02618	.02884	.03150	.03416	.03682	.03948	.04214	.04480	.04746	.05012	.05278	.05544	.05810	.06076	.06342	.06608	.06874	.07140		
1	.03945	.04211	.04477	.04743	.05009	.05275	.05541	.05807	.06073	.06339	.06605	.06871	.07137	.07403	.07669	.07935	.08201	.08467	.08733		
2	.05534	.05800	.06066	.06332	.06598	.06864	.07130	.07396	.07662	.07928	.08194	.08460	.08726	.08992	.09258	.09524	.09790	.10056	.10322		
3	.06458	.06724	.06990	.07256	.07522	.07788	.08054	.08320	.08586	.08852	.09118	.09384	.09650	.09916	.10182	.10448	.10714	.10980	.11246		
4	.07123	.07389	.07655	.07921	.08187	.08453	.08719	.08985	.09251	.09517	.09783	.10049	.10315	.10581	.10847	.11113	.11379	.11645	.11911		
5	.07634	.07900	.08166	.08432	.08698	.08964	.09230	.09496	.09762	.10028	.10294	.10560	.10826	.11092	.11358	.11624	.11890	.12156	.12422		
6	.08047	.08313	.08579	.08845	.09111	.09377	.09643	.09909	.10175	.10441	.10707	.10973	.11239	.11505	.11771	.12037	.12303	.12569	.12835		
7	.08403	.08669	.08935	.09201	.09467	.09733	.09999	.10265	.10531	.10797	.11063	.11329	.11595	.11861	.12127	.12393	.12659	.12925	.13191		
8	.08708	.08974	.09240	.09506	.09772	.10038	.10304	.10570	.10836	.11102	.11368	.11634	.11900	.12166	.12432	.12698	.12964	.13230	.13496		
9	.08980	.09246	.09512	.09778	.10044	.10310	.10576	.10842	.11108	.11374	.11640	.11906	.12172	.12438	.12704	.12970	.13236	.13502	.13768		
10	.09223	.09489	.09755	.10021	.10287	.10553	.10819	.11085	.11351	.11617	.11883	.12149	.12415	.12681	.12947	.13213	.13479	.13745	.14011		
11	.09440	.09706	.09972	.10238	.10504	.10770	.11036	.11302	.11568	.11834	.12100	.12366	.12632	.12898	.13164	.13430	.13696	.13962	.14228		
12	.09635	.09901	.10167	.10433	.10699	.10965	.11231	.11497	.11763	.12029	.12295	.12561	.12827	.13093	.13359	.13625	.13891	.14157	.14423		
15	.10153	.10419	.10685	.10951	.11217	.11483	.11749	.12015	.12281	.12547	.12813	.13079	.13345	.13611	.13877	.14143	.14409	.14675	.14941		
18	.10571	.10837	.11099	.11365	.11631	.11897	.12163	.12429	.12695	.12961	.13227	.13493	.13759	.14025	.14291	.14557	.14823	.15089	.15355		
21	.10921	.11187	.11453	.11719	.11985	.12251	.12517	.12783	.13049	.13315	.13581	.13847	.14113	.14379	.14645	.14911	.15177	.15443	.15709		
24	.11227	.11493	.11759	.12025	.12291	.12557	.12823	.13089	.13355	.13621	.13887	.14153	.14419	.14685	.14951	.15217	.15483	.15749	.16015		
30	.11740	.12006	.12272	.12538	.12804	.13070	.13336	.13602	.13868	.14134	.14400	.14666	.14932	.15198	.15464	.15730	.15996	.16262	.16528		
36	.12154	.12420	.12686	.12952	.13218	.13484	.13750	.14016	.14282	.14548	.14814	.15080	.15346	.15612	.15878	.16144	.16410	.16676	.16942		



TABLE 42--Continued

SIZE OF WIRE—B. & S. GAUGE

Inter-axial Distance, Inches	SIZE OF WIRE—B. & S. GAUGE																		
	0000	000	0	1	2	3	4	5	6	7	8	9	10	11	12	13	14	15	
42	12512	12778	13044	13310	13576	13842	14108	14374	14640	14906	15172	15438	15704	15970	16236	16502	16768	17034	17300
48	12814	13080	13346	13612	13878	14144	14410	14676	14942	15208	15474	15740	16006	16272	16538	16804	17070	17336	17602
54	13065	13351	13617	13883	14149	14415	14681	14947	15213	15479	15745	16011	16277	16543	16809	17075	17341	17607	17873
60	13327	13593	13859	14125	14391	14657	14923	15189	15455	15721	15987	16253	16519	16785	17051	17317	17583	17849	18115
66	13545	13811	14077	14343	14609	14875	15141	15407	15673	15939	16205	16471	16737	17003	17269	17535	17801	18067	18333
72	13745	14011	14277	14543	14809	15075	15341	15607	15873	16139	16405	16671	16937	17203	17469	17735	18001	18267	18533
78	13930	14196	14462	14728	14994	15260	15526	15792	16058	16324	16590	16856	17122	17388	17654	17920	18186	18452	18718
84	14099	14365	14631	14897	15163	15429	15695	15961	16227	16493	16759	17025	17291	17557	17823	18089	18355	18621	18887
90	14258	14524	14790	15056	15322	15588	15854	16120	16386	16652	16918	17184	17450	17716	17982	18248	18514	18780	19046
96	14405	14671	14937	15203	15469	15735	16001	16267	16533	16799	17065	17331	17597	17863	18129	18395	18661	18927	19193
102	14545	14811	15077	15343	15609	15875	16141	16407	16673	16939	17205	17471	17737	18003	18269	18535	18801	19067	19333
108	14676	14942	15208	15474	15740	16006	16272	16538	16804	17070	17336	17602	17868	18134	18400	18666	18932	19198	19464
114	14801	15067	15333	15599	15865	16131	16397	16663	16929	17195	17461	17727	17993	18259	18525	18791	19057	19323	19589
120	14918	15184	15450	15716	15982	16248	16514	16780	17046	17312	17578	17844	18110	18376	18642	18908	19174	19440	19706
126	15027	15293	15559	15825	16091	16357	16623	16889	17155	17421	17687	17953	18219	18485	18751	19017	19283	19549	19815
132	15133	15399	15665	15931	16197	16463	16729	16995	17261	17527	17793	18059	18325	18591	18857	19123	19389	19655	19921
138	15234	15500	15766	16032	16298	16564	16830	17096	17362	17628	17894	18160	18426	18692	18958	19224	19490	19756	20022
144	15332	15598	15864	16130	16396	16662	16928	17194	17460	17726	17992	18258	18524	18790	19056	19322	19588	19854	20120
150	15427	15693	15959	16225	16491	16757	17023	17289	17555	17821	18087	18353	18619	18885	19151	19417	19683	19949	20215
156	15517	15783	16049	16315	16581	16847	17113	17379	17645	17911	18177	18443	18709	18975	19241	19507	19773	20039	20305
162	15604	15870	16136	16402	16668	16934	17200	17466	17732	17998	18264	18530	18796	19062	19328	19594	19860	20126	20392
168	15688	15954	16220	16486	16752	17018	17284	17550	17816	18082	18348	18614	18880	19146	19412	19678	19944	20210	20476
174	15765	16032	16298	16564	16830	17096	17362	17628	17894	18160	18426	18692	18958	19224	19490	19756	20022	20288	20554
180	15845	16111	16377	16643	16909	17175	17441	17707	17973	18239	18505	18771	19037	19303	19569	19835	20101	20367	20633

CONDUCTORS AND WIRE TABLES

Sec. 3

X - (0.0283 L) Ohms		INDUCTIVE REACTANCE Ohms per 1000 Feet (for one wire)													SOLID CONDUCTORS 100 Cycles*					
		0000	000	00	0	1	2	3	4	5	6	7	8	9	10	11	12	13	14	15
Inter-axial Distance, Inches	SIZE OF WIRE—B. & S. GAUGE																			
	3/8	1/2	3/4	1	2	3	4	5	6	7	8	9	10	11	12	13	14	15		
1	.03713	.04156	.04599	.05042	.05485	.05928	.06371	.06814	.07257	.07700	.08143	.08586	.09029	.09472	.09915	.10358	.10801			
2	.03927	.04370	.04813	.05256	.05699	.06142	.06585	.07028	.07471	.07914	.08357	.08800	.09243	.09686	.10129	.10572	.11015	.11458	.11901	
3	.05473	.05916	.06359	.06802	.07245	.07688	.08131	.08574	.09017	.09460	.09903	.10346	.10789	.11232	.11675	.12118	.12561	.13004	.13447	
4	.06575	.07018	.07461	.07904	.08347	.08790	.09233	.09676	.10119	.10562	.11005	.11448	.11891	.12334	.12777	.13220	.13663	.14106	.14549	
5	.09223	.09666	.10109	.10552	.10995	.11438	.11881	.12324	.12767	.13210	.13653	.14096	.14539	.14982	.15425	.15868	.16311	.16754	.17197	
6	.10763	.11206	.11649	.12092	.12535	.12978	.13421	.13864	.14307	.14750	.15193	.15636	.16079	.16522	.16965	.17408	.17851	.18294	.18737	
7	.11871	.12314	.12757	.13200	.13643	.14086	.14529	.14972	.15415	.15858	.16301	.16744	.17187	.17630	.18073	.18516	.18959	.19402	.19845	
8	.12723	.13166	.13609	.14052	.14495	.14938	.15381	.15824	.16267	.16710	.17153	.17596	.18039	.18482	.18925	.19368	.19811	.20254	.20697	
9	.13411	.13854	.14297	.14740	.15183	.15626	.16069	.16512	.16955	.17398	.17841	.18284	.18727	.19170	.19613	.20056	.20499	.20942	.21385	
10	.14005	.14448	.14891	.15334	.15777	.16220	.16663	.17106	.17549	.17992	.18435	.18878	.19321	.19764	.20207	.20650	.21093	.21536	.21979	
11	.14514	.14957	.15400	.15843	.16286	.16729	.17172	.17615	.18058	.18501	.18944	.19387	.19830	.20273	.20716	.21159	.21602	.22045	.22488	
12	.14987	.15430	.15873	.16316	.16759	.17202	.17645	.18088	.18531	.18974	.19417	.19860	.20303	.20746	.21189	.21632	.22075	.22518	.22961	
13	.15437	.15880	.16323	.16766	.17209	.17652	.18095	.18538	.18981	.19424	.19867	.20310	.20753	.21196	.21639	.22082	.22525	.22968	.23411	
14	.15773	.16216	.16659	.17102	.17545	.17988	.18431	.18874	.19317	.19760	.20203	.20646	.21089	.21532	.21975	.22418	.22861	.23304	.23747	
15	.16059	.16502	.16945	.17388	.17831	.18274	.18717	.19160	.19603	.20046	.20489	.20932	.21375	.21818	.22261	.22704	.23147	.23590	.24033	
16	.16921	.17364	.17807	.18250	.18693	.19136	.19579	.20022	.20465	.20908	.21351	.21794	.22237	.22680	.23123	.23566	.24009	.24452	.24895	
17	.17612	.18055	.18498	.18941	.19384	.19827	.20270	.20713	.21156	.21599	.22042	.22485	.22928	.23371	.23814	.24257	.24700	.25143	.25586	
18	.18202	.18645	.19088	.19531	.19974	.20417	.20860	.21303	.21746	.22189	.22632	.23075	.23518	.23961	.24404	.24847	.25290	.25733	.26176	
19	.18711	.19154	.19597	.20040	.20483	.20926	.21369	.21812	.22255	.22698	.23141	.23584	.24027	.24470	.24913	.25356	.25799	.26242	.26685	
20	.19566	.20009	.20452	.20895	.21338	.21781	.22224	.22667	.23110	.23553	.23996	.24439	.24882	.25325	.25768	.26211	.26654	.27097	.27540	
21	.20257	.20700	.21143	.21586	.22029	.22472	.22915	.23358	.23801	.24244	.24687	.25130	.25573	.26016	.26459	.26902	.27345	.27788	.28231	

TABLE 43—Continued

SIZE OF WIRE—B. & S. GAUGE

Inter-axial Distance, Inches	SIZE OF WIRE—B. & S. GAUGE																		
	0000	000	0	1	2	3	4	5	6	7	8	9	10	11	12	13	14	15	
42	20854	21297	21740	22183	22626	23069	23512	23955	24398	24841	25284	25727	26170	26613	27056	27499	27942	28385	28828
48	21357	21800	22243	22686	23129	23572	24015	24458	24901	25344	25787	26230	26673	27116	27559	28002	28445	28888	29331
54	21860	22303	22746	23189	23632	24075	24518	24961	25404	25847	26290	26733	27176	27619	28062	28505	28948	29391	29834
60	22363	22806	23249	23692	24135	24578	25021	25464	25907	26350	26793	27236	27679	28122	28565	29008	29451	29894	30337
66	22866	23309	23752	24195	24638	25081	25524	25967	26410	26853	27296	27739	28182	28625	29068	29511	29954	30397	30840
72	23369	23812	24255	24698	25141	25584	26027	26470	26913	27356	27799	28242	28685	29128	29571	30014	30457	30900	31343
78	23872	24315	24758	25201	25644	26087	26530	26973	27416	27859	28302	28745	29188	29631	30074	30517	30960	31403	31846
84	24375	24818	25261	25704	26147	26590	27033	27476	27919	28362	28805	29248	29691	30134	30577	31020	31463	31906	32349
90	24878	25321	25764	26207	26650	27093	27536	27979	28422	28865	29308	29751	30194	30637	31080	31523	31966	32409	32852
96	25381	25824	26267	26710	27153	27596	28039	28482	28925	29368	29811	30254	30697	31140	31583	32026	32469	32912	33355
102	25884	26327	26770	27213	27656	28099	28542	28985	29428	29871	30314	30757	31200	31643	32086	32529	32972	33415	33858
108	26387	26830	27273	27716	28159	28602	29045	29488	29931	30374	30817	31260	31703	32146	32589	33032	33475	33918	34361
114	26890	27333	27776	28219	28662	29105	29548	29991	30434	30877	31320	31763	32206	32649	33092	33535	33978	34421	34864
120	27393	27836	28279	28722	29165	29608	30051	30494	30937	31380	31823	32266	32709	33152	33595	34038	34481	34924	35367
126	27896	28339	28782	29225	29668	30111	30554	30997	31440	31883	32326	32769	33212	33655	34098	34541	34984	35427	35870
132	28399	28842	29285	29728	30171	30614	31057	31500	31943	32386	32829	33272	33715	34158	34601	35044	35487	35930	36373
138	28902	29345	29788	30231	30674	31117	31560	32003	32446	32889	33332	33775	34218	34661	35104	35547	35990	36433	36876
144	29405	29848	30291	30734	31177	31620	32063	32506	32949	33392	33835	34278	34721	35164	35607	36050	36493	36936	37379
150	29908	30351	30794	31237	31680	32123	32566	33009	33452	33895	34338	34781	35224	35667	36110	36553	36996	37439	37882
156	30411	30854	31297	31740	32183	32626	33069	33512	33955	34398	34841	35284	35727	36170	36613	37056	37499	37942	38385
162	30914	31357	31800	32243	32686	33129	33572	34015	34458	34901	35344	35787	36230	36673	37116	37559	38002	38445	38888
168	31417	31860	32303	32746	33189	33632	34075	34518	34961	35404	35847	36290	36733	37176	37619	38062	38505	38948	39391
174	31920	32363	32806	33249	33692	34135	34578	35021	35464	35907	36350	36793	37236	37679	38122	38565	39008	39451	39894
180	32423	32866	33309	33752	34195	34638	35081	35524	35967	36410	36853	37296	37739	38182	38625	39068	39511	39954	40397

\* This table is furnished for calculating inductive reactance at any frequency, values at any frequency being proportional to those here given.

**TABLE 44**  
**INDUCTIVE REACTANCE**  
Ohms per 1000 Feet of Stranded Cable (for one wire)

STRAINED CABLES  
25 Cycles

CIRCULAR MILS.—SIZE OF CONDUCTOR—B. & S. GAUGE

Inter-axial Distance, Inches	CIRCULAR MILS.—SIZE OF CONDUCTOR—B. & S. GAUGE													
	500,000	450,000	400,000	350,000	300,000	250,000	0000	000	00	0	1	2	3	4
1	.0119	.0124	.0130	.0136	.0143	.0152	.0160	.0171	.0183	.0193	.0204	.0216	.0227	.0238
2	.0185	.0190	.0196	.0202	.0209	.0218	.0226	.0237	.0248	.0259	.0270	.0282	.0293	.0304
3	.0224	.0229	.0235	.0241	.0248	.0257	.0265	.0276	.0287	.0298	.0309	.0321	.0332	.0343
4	.0251	.0256	.0262	.0268	.0275	.0284	.0292	.0303	.0314	.0325	.0336	.0348	.0359	.0370
5	.0273	.0278	.0284	.0290	.0297	.0306	.0314	.0325	.0336	.0347	.0358	.0370	.0381	.0392
6	.0290	.0295	.0301	.0307	.0314	.0323	.0331	.0342	.0353	.0364	.0375	.0387	.0398	.0409
9	.0329	.0334	.0340	.0346	.0353	.0362	.0370	.0381	.0392	.0403	.0414	.0426	.0437	.0448
12	.0357	.0362	.0368	.0374	.0381	.0389	.0398	.0409	.0420	.0431	.0442	.0454	.0465	.0476
18	.0395	.0400	.0406	.0412	.0419	.0428	.0436	.0447	.0458	.0469	.0480	.0492	.0503	.0514
24	.0423	.0428	.0434	.0440	.0447	.0456	.0464	.0475	.0486	.0497	.0508	.0520	.0531	.0542
30	.0444	.0449	.0455	.0461	.0468	.0477	.0485	.0496	.0507	.0518	.0529	.0541	.0552	.0563
36	.0461	.0466	.0472	.0478	.0485	.0494	.0502	.0513	.0524	.0535	.0546	.0558	.0569	.0580
42	.0476	.0481	.0487	.0493	.0500	.0509	.0517	.0528	.0539	.0550	.0561	.0573	.0584	.0595
48	.0489	.0494	.0500	.0506	.0513	.0522	.0530	.0541	.0552	.0563	.0574	.0586	.0597	.0608
54	.0500	.0505	.0511	.0517	.0524	.0533	.0541	.0552	.0563	.0574	.0585	.0597	.0608	.0619
60	.0510	.0515	.0521	.0527	.0534	.0543	.0551	.0562	.0573	.0584	.0595	.0607	.0618	.0629
72	.0528	.0533	.0539	.0545	.0552	.0561	.0569	.0580	.0591	.0602	.0613	.0625	.0636	.0647
84	.0543	.0548	.0554	.0560	.0567	.0576	.0584	.0595	.0606	.0617	.0628	.0640	.0651	.0662
96	.0555	.0560	.0566	.0572	.0579	.0588	.0596	.0607	.0619	.0630	.0640	.0653	.0663	.0674
108	.0565	.0571	.0577	.0583	.0590	.0599	.0607	.0618	.0629	.0640	.0651	.0663	.0674	.0685
120	.0576	.0581	.0587	.0593	.0600	.0609	.0617	.0628	.0639	.0650	.0661	.0673	.0684	.0695
132	.0585	.0590	.0596	.0602	.0609	.0618	.0626	.0637	.0648	.0659	.0670	.0682	.0693	.0704
144	.0594	.0599	.0605	.0611	.0618	.0627	.0635	.0646	.0657	.0668	.0679	.0691	.0702	.0713
156	.0601	.0606	.0612	.0618	.0625	.0634	.0642	.0653	.0664	.0675	.0686	.0698	.0709	.0720
168	.0608	.0613	.0619	.0625	.0632	.0641	.0649	.0659	.0671	.0682	.0693	.0705	.0716	.0727
180	.0615	.0620	.0626	.0632	.0639	.0648	.0656	.0667	.0678	.0689	.0700	.0712	.0723	.0734

**TABLE 45**  
**INDUCTIVE REACTANCE**  
 Ohms per 1000 Feet of Stranded Cable (for one wire)

STRAINED CABLES

60 Cycles

CIRCULAR MILS.—SIZE OF CONDUCTOR—B. & S. GAUGE

Interaxial Distance, Inches	CIRCULAR MILS.—SIZE OF CONDUCTOR—B. & S. GAUGE													
	500,000	450,000	400,000	350,000	300,000	250,000	0000	000	00	0	1	2	3	4
1	.0286	.0297	.0311	.0326	.0344	.0365	.0384	.0411	.0437	.0464	.0491	.0519	.0545	.0572
2	.0445	.0456	.0470	.0485	.0503	.0524	.0543	.0570	.0596	.0623	.0650	.0678	.0704	.0731
3	.0538	.0549	.0563	.0578	.0596	.0617	.0636	.0663	.0689	.0716	.0743	.0771	.0797	.0824
4	.0604	.0615	.0629	.0644	.0662	.0683	.0702	.0729	.0755	.0782	.0809	.0837	.0863	.0890
5	.0655	.0666	.0680	.0695	.0713	.0734	.0753	.0780	.0806	.0833	.0860	.0888	.0915	.0942
6	.0696	.0707	.0721	.0736	.0754	.0775	.0794	.0821	.0847	.0874	.0901	.0928	.0955	.0982
9	.0790	.0801	.0815	.0830	.0848	.0869	.0888	.0915	.0941	.0968	.0995	.1023	.1049	.1076
12	.0855	.0866	.0880	.0895	.0913	.0934	.0953	.0980	.1006	.1033	.1060	.1088	.1114	.1141
18	.0943	.0959	.0973	.0988	.1006	.1027	.1046	.1073	.1099	.1126	.1153	.1181	.1207	.1234
24	.1014	.1025	.1039	.1054	.1072	.1093	.1112	.1139	.1165	.1192	.1219	.1247	.1273	.1300
30	.1065	.1076	.1090	.1105	.1123	.1144	.1163	.1190	.1216	.1243	.1270	.1298	.1324	.1351
36	.1107	.1118	.1132	.1147	.1165	.1186	.1205	.1233	.1260	.1285	.1312	.1340	.1366	.1393
42	.1143	.1154	.1168	.1183	.1201	.1222	.1241	.1269	.1294	.1321	.1348	.1376	.1402	.1429
48	.1173	.1184	.1198	.1213	.1231	.1252	.1271	.1298	.1324	.1351	.1378	.1406	.1432	.1459
54	.1200	.1211	.1225	.1240	.1258	.1279	.1298	.1325	.1351	.1378	.1405	.1433	.1459	.1486
60	.1225	.1236	.1250	.1265	.1283	.1304	.1323	.1350	.1376	.1403	.1430	.1458	.1484	.1511
72	.1267	.1278	.1292	.1307	.1325	.1346	.1365	.1392	.1418	.1445	.1472	.1500	.1526	.1553
84	.1302	.1313	.1327	.1342	.1360	.1381	.1400	.1427	.1453	.1480	.1507	.1535	.1561	.1588
96	.1332	.1343	.1357	.1372	.1389	.1411	.1430	.1457	.1483	.1510	.1537	.1565	.1591	.1618
108	.1356	.1367	.1381	.1396	.1413	.1435	.1453	.1481	.1511	.1538	.1565	.1593	.1619	.1646
120	.1383	.1394	.1408	.1423	.1441	.1462	.1481	.1508	.1534	.1561	.1588	.1616	.1642	.1669
132	.1405	.1416	.1430	.1445	.1463	.1484	.1503	.1530	.1556	.1583	.1610	.1633	.1664	.1691
144	.1425	.1436	.1450	.1465	.1483	.1504	.1523	.1550	.1576	.1603	.1630	.1658	.1684	.1711
156	.1443	.1454	.1468	.1483	.1501	.1522	.1541	.1568	.1594	.1621	.1648	.1676	.1702	.1729
168	.1460	.1471	.1485	.1500	.1518	.1539	.1558	.1585	.1611	.1638	.1665	.1693	.1719	.1746
180	.1476	.1487	.1501	.1516	.1534	.1554	.1574	.1601	.1627	.1654	.1681	.1709	.1735	.1762

TABLE 46  
INDUCTIVE REACTANCE  
Ohms per 100 Feet of Standard Cable (for One Wire)

X = 6925L  
L = Milhenries

STRAINED CABLES  
100 Cycles

CIRCULAR MILS.—SIZE OF CONDUCTOR—B. & S. GAUGE

Interaxial Distance, Inches	Circular Mils.—Size of Conductor—B. & S. Gauge													
	500,000	450,000	400,000	350,000	300,000	250,000	0000	000	00	0	1	2	3	4
1	.0476	.0495	.0519	.0544	.0574	.0608	.0639	.0684	.0728	.0772	.0819	.0864	.0908	.0952
2	.0741	.0760	.0783	.0809	.0839	.0873	.0904	.0944	.0993	.1037	.1083	.1129	.1173	.1217
3	.0896	.0915	.0938	.0964	.0994	.1028	.1069	.1104	.1148	.1192	.1238	.1284	.1328	.1372
4	.1052	.1071	.1094	.1120	.1150	.1183	.1219	.1254	.1298	.1342	.1388	.1434	.1478	.1522
5	.1160	.1179	.1202	.1228	.1258	.1292	.1323	.1358	.1392	.1436	.1482	.1528	.1572	.1616
6	.1237	.1256	.1279	.1305	.1335	.1369	.1400	.1435	.1469	.1513	.1559	.1605	.1649	.1693
9	.1425	.1444	.1467	.1493	.1523	.1557	.1588	.1633	.1677	.1721	.1767	.1813	.1857	.1901
12	.1590	.1599	.1622	.1648	.1678	.1712	.1743	.1788	.1832	.1876	.1922	.1968	.2012	.2056
18	.1709	.1709	.1732	.1758	.1788	.1823	.1853	.1898	.1942	.1986	.2032	.2078	.2122	.2166
24	.1775	.1764	.1787	.1813	.1843	.1877	.1918	.1953	.2027	.2071	.2117	.2163	.2207	.2251
30	.1845	.1834	.1857	.1883	.1913	.1947	.1988	.2023	.2097	.2141	.2187	.2233	.2277	.2321
36	.1905	.1894	.1917	.1943	.1973	.2003	.2043	.2078	.2152	.2196	.2242	.2288	.2332	.2376
42	.1955	.1944	.1967	.1993	.2023	.2053	.2093	.2118	.2192	.2236	.2282	.2328	.2372	.2416
48	.1985	.1974	.1997	.2023	.2053	.2087	.2118	.2143	.2217	.2261	.2307	.2353	.2397	.2441
54	.2000	.2019	.2042	.2068	.2098	.2132	.2163	.2188	.2262	.2306	.2352	.2398	.2442	.2486
60	.2040	.2059	.2082	.2108	.2138	.2172	.2203	.2228	.2302	.2346	.2392	.2438	.2482	.2526
72	.2110	.2129	.2152	.2178	.2208	.2242	.2273	.2298	.2372	.2416	.2462	.2508	.2552	.2596
84	.2170	.2189	.2212	.2238	.2268	.2302	.2333	.2358	.2432	.2476	.2522	.2568	.2612	.2656
96	.2220	.2239	.2262	.2288	.2318	.2352	.2383	.2408	.2482	.2526	.2572	.2618	.2662	.2706
108	.2266	.2285	.2308	.2334	.2364	.2398	.2429	.2454	.2528	.2572	.2618	.2664	.2708	.2752
120	.2296	.2315	.2338	.2364	.2394	.2428	.2459	.2484	.2558	.2602	.2648	.2694	.2738	.2782
132	.2341	.2360	.2383	.2409	.2439	.2473	.2504	.2529	.2603	.2647	.2693	.2739	.2783	.2827
144	.2375	.2394	.2417	.2443	.2473	.2507	.2538	.2563	.2637	.2681	.2727	.2773	.2817	.2861
156	.2405	.2424	.2447	.2473	.2503	.2537	.2568	.2593	.2667	.2711	.2757	.2803	.2847	.2891
168	.2433	.2452	.2475	.2501	.2531	.2565	.2596	.2621	.2695	.2739	.2785	.2831	.2875	.2919
180	.2460	.2479	.2502	.2528	.2558	.2592	.2623	.2648	.2722	.2766	.2812	.2858	.2902	.2946

Interaxial Distance, Inches		SOLID CONDUCTORS E=1000 Volts f=25 Cycles																	
		TABLE 47 CHARGING CURRENT SINGLE-PHASE In Amperes per 1000 Feet of Line (2000 ft. of wire)																	
		SIZE OF WIRE—B. & S. GAUGE																	
Chg. Current—.1571 C. Multiply Values by 10 <sup>-3</sup>		0000	000	0	1	2	3	4	5	6	7	8	9	10	11	12	13	14	15
3/8	1100	.0982	.0886	.0811	.0748	.0696	.0650	.0611	.0578	.0548	.0520	.0496	.0470	.0454	.0437	.0419	.0404	.0390	.0377
1/2	1250	.1640	.1462	.1315	.1197	.1098	.1018	.0948	.0885	.0830	.0784	.0748	.0720	.0698	.0676	.0656	.0638	.0622	.0607
5/8	1630	.1857	.1671	.1505	.1378	.1265	.1168	.1088	.1020	.0963	.0914	.0874	.0841	.0811	.0784	.0758	.0734	.0712	.0691
1	2062	.2100	.1922	.1765	.1628	.1505	.1392	.1298	.1215	.1142	.1078	.1022	.0972	.0926	.0884	.0844	.0806	.0770	.0736
2	2652	.2652	.2486	.2339	.2202	.2078	.1964	.1860	.1766	.1681	.1605	.1536	.1472	.1413	.1358	.1306	.1256	.1208	.1162
3	3354	.3354	.3198	.3051	.2912	.2778	.2650	.2530	.2418	.2312	.2211	.2115	.2023	.1935	.1851	.1770	.1691	.1614	.1539
4	4176	.4176	.4030	.3891	.3758	.3630	.3506	.3388	.3274	.3165	.3061	.2961	.2864	.2770	.2680	.2592	.2506	.2422	.2340
5	5018	.5018	.4881	.4750	.4624	.4502	.4384	.4270	.4160	.4054	.3951	.3851	.3753	.3658	.3565	.3474	.3384	.3296	.3210
6	5880	.5880	.5751	.5626	.5504	.5386	.5271	.5160	.5052	.4947	.4844	.4743	.4644	.4547	.4452	.4359	.4267	.4176	.4086
7	6762	.6762	.6641	.6522	.6406	.6292	.6181	.6072	.5965	.5860	.5757	.5655	.5555	.5457	.5360	.5265	.5171	.5078	.4986
8	7674	.7674	.7561	.7450	.7341	.7234	.7129	.7025	.6923	.6822	.6722	.6623	.6525	.6428	.6332	.6237	.6143	.6050	.5958
9	8616	.8616	.8511	.8408	.8306	.8206	.8107	.8009	.7912	.7816	.7721	.7627	.7534	.7442	.7351	.7261	.7171	.7082	.6994
10	9588	.9588	.9491	.9395	.9299	.9205	.9112	.9020	.8929	.8838	.8748	.8658	.8569	.8481	.8394	.8308	.8223	.8138	.8054
11	10590	1.0590	1.0500	1.0411	1.0322	1.0234	1.0147	1.0061	0.9976	0.9891	0.9807	0.9724	0.9642	0.9561	0.9480	0.9400	0.9320	0.9241	0.9162
12	11622	1.1622	1.1541	1.1461	1.1381	1.1302	1.1223	1.1145	1.1067	1.0990	1.0913	1.0837	1.0761	1.0686	1.0611	1.0537	1.0463	1.0390	1.0317
15	14580	1.4580	1.4511	1.4442	1.4374	1.4306	1.4239	1.4172	1.4106	1.4040	1.3975	1.3910	1.3845	1.3781	1.3717	1.3653	1.3590	1.3527	1.3464
18	17670	1.7670	1.7611	1.7552	1.7493	1.7435	1.7377	1.7319	1.7262	1.7205	1.7148	1.7091	1.7034	1.6977	1.6921	1.6864	1.6808	1.6751	1.6695
21	20880	2.0880	2.0831	2.0782	2.0733	2.0684	2.0635	2.0586	2.0537	2.0488	2.0439	2.0390	2.0341	2.0292	2.0243	2.0194	2.0145	2.0096	2.0047
24	24210	2.4210	2.4171	2.4132	2.4093	2.4054	2.4015	2.3976	2.3937	2.3898	2.3859	2.3820	2.3781	2.3742	2.3703	2.3664	2.3625	2.3586	2.3547
30	32700	3.2700	3.2671	3.2642	3.2613	3.2584	3.2555	3.2526	3.2497	3.2468	3.2439	3.2410	3.2381	3.2352	3.2323	3.2294	3.2265	3.2236	3.2207
36	39480	3.9480	3.9461	3.9442	3.9423	3.9404	3.9385	3.9366	3.9347	3.9328	3.9309	3.9290	3.9271	3.9252	3.9233	3.9214	3.9195	3.9176	3.9157

TABLE 47—Continued

SIZE OF WIRE—B. & S. GAUGE

Interaxial Distance, Inches	SIZE OF WIRE—B. & S. GAUGE																	
	0000	000	0	1	2	3	4	5	6	7	8	9	10	11	12	13	14	15
42	.0156	.0245	.0259	.0254	.0229	.0235	.0251	.0217	.0213	.0209	.0206	.0201	.0196	.0195	.0192	.0189	.0185	.0183
48	.0190	.0259	.0254	.0229	.0225	.0230	.0217	.0213	.0209	.0204	.0201	.0196	.0195	.0191	.0189	.0185	.0182	.0179
54	.0243	.0239	.0234	.0229	.0225	.0218	.0213	.0209	.0204	.0201	.0196	.0195	.0191	.0189	.0185	.0182	.0179	.0176
60	.0289	.0234	.0229	.0225	.0220	.0217	.0213	.0209	.0204	.0201	.0196	.0195	.0191	.0189	.0185	.0182	.0179	.0174
66	.0236	.0231	.0226	.0221	.0217	.0214	.0209	.0204	.0201	.0196	.0195	.0191	.0189	.0185	.0182	.0179	.0174	.0172
72	.0251	.0220	.0223	.0218	.0214	.0209	.0204	.0200	.0196	.0192	.0189	.0186	.0183	.0181	.0177	.0175	.0172	.0170
78	.0223	.0224	.0220	.0215	.0212	.0209	.0204	.0200	.0196	.0194	.0190	.0187	.0184	.0181	.0179	.0175	.0171	.0168
84	.0235	.0221	.0217	.0213	.0209	.0205	.0202	.0198	.0195	.0192	.0189	.0185	.0182	.0179	.0177	.0174	.0169	.0166
90	.0233	.0219	.0215	.0210	.0207	.0203	.0200	.0196	.0193	.0190	.0186	.0183	.0180	.0178	.0175	.0172	.0167	.0165
96	.0220	.0216	.0212	.0208	.0205	.0201	.0198	.0194	.0191	.0188	.0185	.0182	.0178	.0174	.0171	.0168	.0165	.0164
102	.0215	.0214	.0211	.0206	.0203	.0199	.0196	.0192	.0189	.0186	.0183	.0180	.0177	.0175	.0173	.0170	.0167	.0165
108	.0216	.0212	.0208	.0204	.0201	.0197	.0194	.0191	.0188	.0185	.0182	.0179	.0176	.0174	.0171	.0169	.0166	.0164
114	.0214	.0210	.0207	.0203	.0199	.0196	.0193	.0189	.0186	.0183	.0181	.0177	.0175	.0173	.0170	.0168	.0165	.0160
120	.0212	.0208	.0205	.0201	.0198	.0195	.0191	.0188	.0185	.0182	.0179	.0176	.0172	.0172	.0169	.0166	.0162	.0159
126	.0211	.0207	.0203	.0200	.0197	.0193	.0190	.0187	.0184	.0181	.0178	.0175	.0172	.0170	.0168	.0165	.0161	.0158
132	.0209	.0205	.0202	.0198	.0195	.0192	.0189	.0186	.0183	.0180	.0177	.0174	.0171	.0169	.0167	.0164	.0160	.0158
138	.0208	.0204	.0201	.0197	.0194	.0191	.0188	.0185	.0182	.0179	.0176	.0173	.0170	.0168	.0166	.0163	.0161	.0157
144	.0207	.0203	.0199	.0196	.0193	.0190	.0186	.0184	.0181	.0178	.0175	.0172	.0169	.0167	.0165	.0162	.0156	.0156
150	.0205	.0201	.0196	.0191	.0188	.0185	.0183	.0180	.0177	.0174	.0171	.0168	.0166	.0164	.0162	.0159	.0157	.0155
156	.0204	.0200	.0196	.0190	.0187	.0184	.0182	.0179	.0176	.0173	.0170	.0167	.0166	.0164	.0161	.0159	.0157	.0154
162	.0203	.0199	.0195	.0188	.0185	.0183	.0181	.0178	.0175	.0172	.0170	.0166	.0165	.0163	.0160	.0158	.0156	.0154
168	.0202	.0198	.0193	.0188	.0185	.0183	.0180	.0177	.0174	.0171	.0169	.0166	.0164	.0162	.0160	.0157	.0155	.0153
174	.0201	.0197	.0194	.0187	.0184	.0181	.0179	.0176	.0173	.0170	.0168	.0165	.0163	.0161	.0159	.0157	.0155	.0153
180	.0200	.0196	.0193	.0188	.0185	.0183	.0180	.0178	.0175	.0173	.0170	.0168	.0165	.0163	.0160	.0158	.0156	.0154



**TABLE 48**  
**CHARGING CURRENT**  
Single-Phase  
In Amperes per 1000 Feet of Line (2000 Ft. of Wire)

SOLID CONDUCTORS  
E-1000 Volts  
f=60 Cycles

Chg. Current= .377C.  
Multiply Values by 10<sup>-1</sup>

SIZE OF WIRE—B. & S. GAUGE

Interaxial Distance, Inches	SIZE OF WIRE—B. & S. GAUGE																		
	0000	000	0	1	2	3	4	5	6	7	8	9	10	11	12	13	14	15	
1/8	1.5870	.8725	.5770	4.857	3.550	3.016	2.534	2.122	1.940	1.784	1.673	1.537	1.466	1.383	1.312	1.247	1.187	1.138	1.093
1/4	.8915	.5257	.3411	2.483	2.228	2.031	1.728	1.510	1.512	1.425	1.346	1.262	1.217	1.165	1.112	1.067	1.025	.983	.943
3/8	.6642	.3355	.2126	1.945	1.794	1.670	1.569	1.466	1.316	1.247	1.190	1.128	1.090	1.048	1.006	.969	.935	.905	.875
1	.5664	.2470	.1877	1.516	1.252	1.195	1.138	1.063	1.048	1.006	.973	.935	.897	.875	.822	.800	.775	.754	.734
2	.4282	.1221	.1157	1.116	1.070	1.030	.990	.954	.920	.880	.853	.837	.803	.781	.743	.724	.705	.686	.668
3	.3142	.1083	.1023	.910	.972	.932	.892	.875	.838	.822	.800	.776	.751	.731	.716	.698	.678	.664	.645
4	.2152	.1010	.972	.858	.908	.878	.852	.826	.800	.777	.754	.735	.713	.697	.678	.664	.648	.633	.618
5	.1692	.0954	.9520	.8690	.883	.837	.811	.784	.765	.742	.724	.705	.687	.671	.652	.637	.620	.604	.589
6	.1342	.0912	.882	.826	.803	.780	.758	.735	.716	.697	.682	.660	.648	.634	.618	.607	.592	.577	.562
7	.1042	.0822	.800	.776	.754	.735	.716	.698	.678	.664	.648	.630	.618	.603	.592	.577	.562	.547	.532
8	.0874	.0848	.799	.776	.754	.735	.716	.698	.679	.664	.648	.630	.618	.603	.592	.577	.562	.547	.532
9	.0829	.0826	.800	.776	.753	.731	.717	.698	.682	.664	.648	.633	.614	.603	.589	.576	.562	.547	.532
10	.0829	.0803	.798	.773	.750	.731	.717	.698	.682	.664	.648	.633	.614	.603	.589	.576	.562	.547	.532
11	.0810	.0788	.795	.774	.754	.735	.716	.698	.682	.664	.648	.633	.614	.603	.589	.576	.562	.547	.532
12	.0765	.0765	.795	.774	.754	.735	.716	.698	.682	.664	.648	.633	.614	.603	.589	.576	.562	.547	.532
15	.0735	.0715	.785	.764	.745	.726	.707	.689	.672	.654	.637	.620	.603	.587	.570	.554	.538	.522	.506
18	.0709	.0690	.780	.760	.741	.722	.703	.685	.668	.651	.634	.617	.600	.584	.568	.552	.536	.520	.504
21	.0686	.0671	.775	.756	.737	.718	.700	.682	.665	.648	.631	.614	.597	.581	.565	.549	.533	.517	.501
24	.0665	.0651	.770	.752	.733	.714	.696	.678	.661	.644	.627	.610	.593	.577	.561	.545	.529	.513	.497
30	.0645	.0641	.765	.748	.729	.710	.692	.674	.657	.640	.623	.606	.589	.573	.557	.541	.525	.509	.493
36	.0633	.0633	.760	.743	.724	.705	.686	.668	.651	.634	.617	.600	.583	.567	.551	.535	.519	.503	.487

TABLE 48—Continued

SIZE OF WIRE—B. & S. GAUGE

Interaxial  
Distance,  
Inches

	0000	000	0	1	2	3	4	5	6	7	8	9	10	11	12	13	14	15
42	.0514	.0500	.0508	.0522	.0530	.0539	.0532	.0520	.0509	.0502	.0494	.0483	.0475	.0468	.0460	.0453	.0445	.0437
48	.0642	.0620	.0631	.0652	.0660	.0669	.0652	.0630	.0610	.0602	.0594	.0583	.0575	.0568	.0560	.0553	.0545	.0537
54	.0804	.0773	.0790	.0828	.0838	.0848	.0822	.0790	.0760	.0752	.0744	.0733	.0725	.0718	.0710	.0703	.0695	.0687
60	.0978	.0932	.0954	.1000	.1012	.1023	.0988	.0948	.0910	.0902	.0894	.0883	.0875	.0868	.0860	.0853	.0845	.0837
66	.0625	.0613	.0624	.0652	.0660	.0669	.0652	.0630	.0610	.0602	.0594	.0583	.0575	.0568	.0560	.0553	.0545	.0537
72	.0654	.0643	.0654	.0682	.0690	.0699	.0682	.0660	.0640	.0632	.0624	.0613	.0605	.0598	.0590	.0583	.0575	.0567
78	.0648	.0637	.0648	.0676	.0684	.0693	.0676	.0654	.0634	.0626	.0618	.0607	.0600	.0593	.0585	.0578	.0570	.0562
84	.0642	.0630	.0641	.0669	.0677	.0686	.0669	.0647	.0627	.0619	.0611	.0600	.0593	.0586	.0578	.0571	.0563	.0555
90	.0636	.0625	.0636	.0664	.0672	.0681	.0664	.0642	.0622	.0614	.0606	.0595	.0588	.0581	.0573	.0566	.0558	.0550
96	.0629	.0619	.0630	.0658	.0666	.0675	.0658	.0636	.0616	.0608	.0600	.0589	.0582	.0575	.0567	.0560	.0552	.0544
102	.0624	.0614	.0625	.0653	.0661	.0670	.0653	.0631	.0611	.0603	.0595	.0584	.0577	.0570	.0562	.0555	.0547	.0539
108	.0618	.0608	.0619	.0647	.0655	.0664	.0647	.0625	.0605	.0597	.0589	.0578	.0571	.0564	.0556	.0549	.0541	.0533
114	.0614	.0606	.0617	.0645	.0653	.0662	.0645	.0623	.0603	.0595	.0587	.0576	.0569	.0562	.0554	.0547	.0539	.0531
120	.0610	.0600	.0611	.0639	.0647	.0656	.0639	.0617	.0597	.0589	.0581	.0570	.0563	.0556	.0548	.0541	.0533	.0525
126	.0606	.0597	.0608	.0636	.0644	.0653	.0636	.0614	.0594	.0586	.0578	.0567	.0560	.0553	.0545	.0538	.0530	.0522
132	.0602	.0593	.0604	.0632	.0640	.0649	.0632	.0610	.0590	.0582	.0574	.0563	.0556	.0549	.0541	.0534	.0526	.0518
138	.0599	.0590	.0601	.0629	.0637	.0646	.0629	.0607	.0587	.0579	.0571	.0560	.0553	.0546	.0538	.0531	.0523	.0515
144	.0596	.0587	.0598	.0626	.0634	.0643	.0626	.0604	.0584	.0576	.0568	.0557	.0550	.0543	.0535	.0528	.0520	.0512
150	.0592	.0584	.0595	.0623	.0631	.0640	.0623	.0601	.0581	.0573	.0565	.0554	.0547	.0540	.0532	.0525	.0517	.0509
156	.0589	.0581	.0592	.0620	.0628	.0637	.0620	.0598	.0578	.0570	.0562	.0551	.0544	.0537	.0529	.0522	.0514	.0506
162	.0586	.0578	.0589	.0617	.0625	.0634	.0617	.0595	.0575	.0567	.0559	.0548	.0541	.0534	.0526	.0519	.0511	.0503
168	.0584	.0576	.0587	.0615	.0623	.0632	.0615	.0593	.0573	.0565	.0557	.0546	.0539	.0532	.0524	.0517	.0509	.0501
174	.0582	.0574	.0585	.0613	.0621	.0630	.0613	.0591	.0571	.0563	.0555	.0544	.0537	.0530	.0522	.0515	.0507	.0499
180	.0579	.0571	.0582	.0610	.0618	.0627	.0610	.0588	.0568	.0560	.0552	.0541	.0534	.0527	.0519	.0512	.0504	.0496

Interaxial Distance, Inches		SOLID CONDUCTORS E = 1000 Volts f = 100 Cycles																	
		TABLE 49 CHARGING CURRENT SINGLE-PHASE																	
		In Amperes per 1000 Feet of Line (2000 Feet of Wire)																	
		SIZE OF WIRE—B. & S. GAUGE																	
		0000	000	0	1	2	3	4	5	6	7	8	0	10	11	12	13	14	15
1/8	3.311	1.455	1.128	1.066	1.046	1.028	1.011	1.000	.990	.980	.970	.960	.950	.940	.930	.920	.910	.900	.890
1/4	3.623	1.453	1.128	1.066	1.046	1.028	1.011	1.000	.990	.980	.970	.960	.950	.940	.930	.920	.910	.900	.890
3/8	4.011	1.453	1.128	1.066	1.046	1.028	1.011	1.000	.990	.980	.970	.960	.950	.940	.930	.920	.910	.900	.890
1	4.411	1.453	1.128	1.066	1.046	1.028	1.011	1.000	.990	.980	.970	.960	.950	.940	.930	.920	.910	.900	.890
2	4.811	1.453	1.128	1.066	1.046	1.028	1.011	1.000	.990	.980	.970	.960	.950	.940	.930	.920	.910	.900	.890
3	5.211	1.453	1.128	1.066	1.046	1.028	1.011	1.000	.990	.980	.970	.960	.950	.940	.930	.920	.910	.900	.890
4	5.611	1.453	1.128	1.066	1.046	1.028	1.011	1.000	.990	.980	.970	.960	.950	.940	.930	.920	.910	.900	.890
5	6.011	1.453	1.128	1.066	1.046	1.028	1.011	1.000	.990	.980	.970	.960	.950	.940	.930	.920	.910	.900	.890
6	6.411	1.453	1.128	1.066	1.046	1.028	1.011	1.000	.990	.980	.970	.960	.950	.940	.930	.920	.910	.900	.890
7	6.811	1.453	1.128	1.066	1.046	1.028	1.011	1.000	.990	.980	.970	.960	.950	.940	.930	.920	.910	.900	.890
8	7.211	1.453	1.128	1.066	1.046	1.028	1.011	1.000	.990	.980	.970	.960	.950	.940	.930	.920	.910	.900	.890
9	7.611	1.453	1.128	1.066	1.046	1.028	1.011	1.000	.990	.980	.970	.960	.950	.940	.930	.920	.910	.900	.890
10	8.011	1.453	1.128	1.066	1.046	1.028	1.011	1.000	.990	.980	.970	.960	.950	.940	.930	.920	.910	.900	.890
11	8.411	1.453	1.128	1.066	1.046	1.028	1.011	1.000	.990	.980	.970	.960	.950	.940	.930	.920	.910	.900	.890
12	8.811	1.453	1.128	1.066	1.046	1.028	1.011	1.000	.990	.980	.970	.960	.950	.940	.930	.920	.910	.900	.890
15	9.611	1.453	1.128	1.066	1.046	1.028	1.011	1.000	.990	.980	.970	.960	.950	.940	.930	.920	.910	.900	.890
18	10.411	1.453	1.128	1.066	1.046	1.028	1.011	1.000	.990	.980	.970	.960	.950	.940	.930	.920	.910	.900	.890
21	11.211	1.453	1.128	1.066	1.046	1.028	1.011	1.000	.990	.980	.970	.960	.950	.940	.930	.920	.910	.900	.890
24	12.011	1.453	1.128	1.066	1.046	1.028	1.011	1.000	.990	.980	.970	.960	.950	.940	.930	.920	.910	.900	.890
30	13.211	1.453	1.128	1.066	1.046	1.028	1.011	1.000	.990	.980	.970	.960	.950	.940	.930	.920	.910	.900	.890
36	14.411	1.453	1.128	1.066	1.046	1.028	1.011	1.000	.990	.980	.970	.960	.950	.940	.930	.920	.910	.900	.890

TABLE 49—Continued

SIZE OF WIRE—B. & S. GAUGE

Interaxial  
Distance,  
Inches

	0000	000	0	1	2	3	4	5	6	7	8	9	10	11	12	13	14	15
42	.0090	.0089	.0088	.0087	.0086	.0085	.0084	.0083	.0082	.0081	.0080	.0079	.0078	.0077	.0076	.0075	.0074	.0073
48	.0074	.0073	.0072	.0071	.0070	.0069	.0068	.0067	.0066	.0065	.0064	.0063	.0062	.0061	.0060	.0059	.0058	.0057
54	.0058	.0057	.0056	.0055	.0054	.0053	.0052	.0051	.0050	.0049	.0048	.0047	.0046	.0045	.0044	.0043	.0042	.0041
60	.0043	.0042	.0041	.0040	.0039	.0038	.0037	.0036	.0035	.0034	.0033	.0032	.0031	.0030	.0029	.0028	.0027	.0026
66	.0034	.0033	.0032	.0031	.0030	.0029	.0028	.0027	.0026	.0025	.0024	.0023	.0022	.0021	.0020	.0019	.0018	.0017
72	.0024	.0023	.0022	.0021	.0020	.0019	.0018	.0017	.0016	.0015	.0014	.0013	.0012	.0011	.0010	.0009	.0008	.0007
78	.0015	.0014	.0013	.0012	.0011	.0010	.0009	.0008	.0007	.0006	.0005	.0004	.0003	.0002	.0001	.0000	.0000	.0000
84	.0003	.0002	.0001	.0000	.0000	.0000	.0000	.0000	.0000	.0000	.0000	.0000	.0000	.0000	.0000	.0000	.0000	.0000
90	.0003	.0002	.0001	.0000	.0000	.0000	.0000	.0000	.0000	.0000	.0000	.0000	.0000	.0000	.0000	.0000	.0000	.0000
96	.0003	.0002	.0001	.0000	.0000	.0000	.0000	.0000	.0000	.0000	.0000	.0000	.0000	.0000	.0000	.0000	.0000	.0000
102	.0003	.0002	.0001	.0000	.0000	.0000	.0000	.0000	.0000	.0000	.0000	.0000	.0000	.0000	.0000	.0000	.0000	.0000
108	.0003	.0002	.0001	.0000	.0000	.0000	.0000	.0000	.0000	.0000	.0000	.0000	.0000	.0000	.0000	.0000	.0000	.0000
114	.0003	.0002	.0001	.0000	.0000	.0000	.0000	.0000	.0000	.0000	.0000	.0000	.0000	.0000	.0000	.0000	.0000	.0000
120	.0003	.0002	.0001	.0000	.0000	.0000	.0000	.0000	.0000	.0000	.0000	.0000	.0000	.0000	.0000	.0000	.0000	.0000
126	.0003	.0002	.0001	.0000	.0000	.0000	.0000	.0000	.0000	.0000	.0000	.0000	.0000	.0000	.0000	.0000	.0000	.0000
132	.0003	.0002	.0001	.0000	.0000	.0000	.0000	.0000	.0000	.0000	.0000	.0000	.0000	.0000	.0000	.0000	.0000	.0000
138	.0003	.0002	.0001	.0000	.0000	.0000	.0000	.0000	.0000	.0000	.0000	.0000	.0000	.0000	.0000	.0000	.0000	.0000
144	.0003	.0002	.0001	.0000	.0000	.0000	.0000	.0000	.0000	.0000	.0000	.0000	.0000	.0000	.0000	.0000	.0000	.0000
150	.0003	.0002	.0001	.0000	.0000	.0000	.0000	.0000	.0000	.0000	.0000	.0000	.0000	.0000	.0000	.0000	.0000	.0000
156	.0003	.0002	.0001	.0000	.0000	.0000	.0000	.0000	.0000	.0000	.0000	.0000	.0000	.0000	.0000	.0000	.0000	.0000
162	.0003	.0002	.0001	.0000	.0000	.0000	.0000	.0000	.0000	.0000	.0000	.0000	.0000	.0000	.0000	.0000	.0000	.0000
168	.0003	.0002	.0001	.0000	.0000	.0000	.0000	.0000	.0000	.0000	.0000	.0000	.0000	.0000	.0000	.0000	.0000	.0000
174	.0003	.0002	.0001	.0000	.0000	.0000	.0000	.0000	.0000	.0000	.0000	.0000	.0000	.0000	.0000	.0000	.0000	.0000
180	.0003	.0002	.0001	.0000	.0000	.0000	.0000	.0000	.0000	.0000	.0000	.0000	.0000	.0000	.0000	.0000	.0000	.0000

Interaxial Distance, Inches		CIRCULAR MILS.—SIZE OF CONDUCTOR—B. & S. GAUGE												
		500,000	450,000	400,000	350,000	300,000	250,000	0000	000	00	0	1	2	3
1	.3650	.2843	.2205	.1712	.1465	.1303	.1126	.1003	.0910	.0820	.0754	.0702	.0655	.0618
2	.0980	.0777	.0636	.0534	.0475	.0430	.0390	.0361	.0338	.0320	.0304	.0291	.0280	.0270
3	.0771	.0638	.0545	.0479	.0432	.0401	.0376	.0356	.0340	.0326	.0314	.0304	.0295	.0287
4	.0613	.0534	.0478	.0430	.0399	.0374	.0354	.0340	.0328	.0318	.0310	.0303	.0296	.0290
5	.0550	.0486	.0442	.0403	.0374	.0352	.0335	.0323	.0314	.0306	.0299	.0293	.0287	.0282
6	.0509	.0457	.0419	.0384	.0358	.0339	.0324	.0314	.0306	.0299	.0293	.0288	.0283	.0279
9	.0437	.0407	.0381	.0358	.0340	.0328	.0318	.0310	.0303	.0297	.0292	.0287	.0283	.0279
12	.0398	.0376	.0358	.0342	.0329	.0320	.0312	.0305	.0299	.0294	.0289	.0285	.0281	.0277
18	.0354	.0347	.0336	.0329	.0323	.0318	.0314	.0310	.0306	.0302	.0298	.0294	.0291	.0287
24	.0328	.0323	.0319	.0314	.0310	.0306	.0302	.0298	.0294	.0291	.0287	.0284	.0281	.0277
30	.0311	.0306	.0302	.0297	.0292	.0287	.0282	.0277	.0272	.0268	.0264	.0261	.0257	.0254
36	.0298	.0294	.0290	.0286	.0281	.0276	.0271	.0266	.0262	.0258	.0254	.0251	.0247	.0243
42	.0288	.0284	.0281	.0276	.0271	.0266	.0261	.0256	.0252	.0248	.0244	.0241	.0237	.0233
48	.0280	.0276	.0273	.0268	.0263	.0258	.0253	.0248	.0244	.0240	.0236	.0233	.0229	.0226
54	.0273	.0269	.0266	.0262	.0258	.0254	.0250	.0246	.0242	.0238	.0234	.0231	.0227	.0224
60	.0267	.0264	.0261	.0257	.0253	.0249	.0245	.0241	.0237	.0233	.0229	.0225	.0221	.0217
72	.0258	.0255	.0251	.0248	.0244	.0241	.0237	.0233	.0229	.0224	.0221	.0217	.0213	.0210
84	.0250	.0247	.0244	.0241	.0238	.0234	.0231	.0227	.0223	.0218	.0215	.0211	.0207	.0202
96	.0243	.0241	.0239	.0236	.0232	.0229	.0225	.0221	.0217	.0213	.0209	.0205	.0201	.0196
108	.0239	.0236	.0234	.0231	.0228	.0224	.0221	.0217	.0213	.0209	.0205	.0201	.0196	.0192
120	.0234	.0232	.0229	.0227	.0224	.0220	.0217	.0213	.0209	.0206	.0202	.0198	.0194	.0190
132	.0230	.0228	.0225	.0223	.0220	.0216	.0213	.0209	.0206	.0202	.0198	.0194	.0190	.0187
144	.0227	.0225	.0222	.0219	.0216	.0212	.0209	.0205	.0202	.0198	.0194	.0190	.0187	.0183
156	.0224	.0222	.0219	.0216	.0214	.0211	.0207	.0203	.0200	.0196	.0192	.0188	.0184	.0181
168	.0221	.0219	.0217	.0214	.0212	.0209	.0205	.0201	.0197	.0193	.0189	.0185	.0181	.0178
180	.0218	.0216	.0214	.0212	.0209	.0206	.0202	.0198	.0194	.0190	.0187	.0183	.0179	.0176

STRAINED CONDUCTORS  
f = 25 Cycles  
E = 1000 Volts

TABLE 50  
CHARGING CURRENT  
SINGLE-PHASE

Chg. Current = 1571 C.  
Multiply Values by 10<sup>-4</sup>

In Amperes per 1000 Feet of Line (2000 Feet of Wire)

**TABLE 51**  
**CHARGING CURRENT**  
**SINGLE-PHASE**  
**STRAINED CONDUCTORS**  
*f* = 60 Cycles  
*E* = 1000 Volts

In Amperes per 1000 Feet of Line (3000 Feet of Wire)

CIRCULAR MILS.—SIZE OF CONDUCTOR—B. & S. GAUGE

Interaxial Distance, Inches	CIRCULAR MILS.—SIZE OF CONDUCTOR—B. & S. GAUGE													
	500,000	450,000	400,000	350,000	300,000	250,000	200,000	000	00	0	1	2	3	4
1	.8770	.8320	.7870	.7412	.6952	.6492	.6032	.5572	.5112	.4652	.4192	.3732	.3272	.2812
2	.2590	.2223	.1856	.1489	.1122	.7555	.6988	.6421	.5854	.5287	.4720	.4153	.3586	.3019
3	.1730	.1674	.1618	.1562	.1506	.1450	.1394	.1338	.1282	.1226	.1170	.1114	.1058	.1002
4	.1470	.1425	.1380	.1335	.1290	.1245	.1200	.1155	.1110	.1065	.1020	.975	.930	.885
5	.1320	.1285	.1250	.1215	.1180	.1145	.1110	.1075	.1040	.1005	.970	.935	.900	.865
6	.1221	.1190	.1165	.1135	.1105	.1075	.1045	.1015	.985	.955	.925	.895	.865	.835
9	.1045	.1025	.1005	.984	.961	.938	.915	.892	.869	.846	.823	.800	.777	.755
12	.0953	.0933	.0920	.0901	.0882	.0865	.0848	.0831	.0814	.0797	.0780	.0763	.0746	.0729
18	.0848	.0833	.0822	.0807	.0792	.0776	.0761	.0745	.0730	.0714	.0699	.0683	.0668	.0652
24	.0758	.0745	.0735	.0724	.0714	.0701	.0688	.0675	.0662	.0649	.0636	.0623	.0610	.0597
30	.0716	.0705	.0696	.0686	.0675	.0663	.0652	.0640	.0629	.0617	.0605	.0593	.0581	.0569
36	.0680	.0671	.0663	.0653	.0643	.0632	.0621	.0610	.0599	.0588	.0577	.0566	.0555	.0544
42	.0647	.0639	.0632	.0624	.0615	.0605	.0595	.0585	.0575	.0565	.0555	.0545	.0535	.0525
48	.0621	.0614	.0607	.0600	.0592	.0584	.0576	.0568	.0560	.0552	.0544	.0536	.0528	.0520
54	.0600	.0594	.0588	.0582	.0576	.0570	.0564	.0558	.0552	.0546	.0540	.0534	.0528	.0522
60	.0581	.0576	.0571	.0566	.0561	.0556	.0551	.0546	.0541	.0536	.0531	.0526	.0521	.0516
72	.0561	.0557	.0553	.0549	.0545	.0541	.0537	.0533	.0529	.0525	.0521	.0517	.0513	.0509
84	.0549	.0546	.0543	.0540	.0537	.0534	.0531	.0528	.0525	.0522	.0519	.0516	.0513	.0510
96	.0544	.0541	.0538	.0535	.0532	.0529	.0526	.0523	.0520	.0517	.0514	.0511	.0508	.0505
108	.0540	.0537	.0534	.0531	.0528	.0525	.0522	.0519	.0516	.0513	.0510	.0507	.0504	.0501
120	.0537	.0534	.0531	.0528	.0525	.0522	.0519	.0516	.0513	.0510	.0507	.0504	.0501	.0498
132	.0535	.0532	.0529	.0526	.0523	.0520	.0517	.0514	.0511	.0508	.0505	.0502	.0499	.0496
144	.0534	.0531	.0528	.0525	.0522	.0519	.0516	.0513	.0510	.0507	.0504	.0501	.0498	.0495
156	.0533	.0530	.0527	.0524	.0521	.0518	.0515	.0512	.0509	.0506	.0503	.0500	.0497	.0494
168	.0530	.0527	.0524	.0521	.0518	.0515	.0512	.0509	.0506	.0503	.0500	.0497	.0494	.0491
180	.0524	.0521	.0518	.0515	.0512	.0509	.0506	.0503	.0500	.0497	.0494	.0491	.0488	.0485

**TABLE 52**  
**CHARGING CURRENT**  
**SINGLE-PHASE**

STRAINED CONDUCTORS  
f = 100 Cycles  
E = 1000 Volts

Chg. Current = .0283 C.  
Multiply Values by 10<sup>-4</sup>

In Amperes per 1000 Feet of Line (2000 Feet of Wire)

CIRCULAR MILS.—SIZE OF CONDUCTOR—B. & S. GAUGE

Interaxial Distance, Inches	CIRCULAR MILS.—SIZE OF CONDUCTOR—B. & S. GAUGE													
	500,000	450,000	400,000	350,000	300,000	250,000	0000	000	00	0	1	2	3	4
1	1.461	1.138	.954	.803	.685	.586	.522	.451	.402	.364	.328	.302	.281	.262
2	.882	.771	.655	.566	.497	.436	.383	.344	.315	.290	.271	.250	.231	.214
3	.688	.609	.529	.469	.423	.387	.353	.326	.306	.297	.287	.279	.272	.265
4	.545	.486	.431	.389	.356	.328	.301	.282	.268	.257	.249	.242	.236	.231
5	.454	.407	.366	.332	.308	.288	.271	.258	.249	.242	.236	.231	.226	.222
6	.390	.354	.323	.296	.277	.261	.248	.238	.232	.227	.223	.219	.215	.212
9	.280	.254	.233	.214	.200	.189	.184	.178	.176	.170	.166	.162	.158	.155
12	.215	.195	.179	.166	.158	.152	.147	.143	.142	.138	.134	.131	.128	.125
18	.155	.142	.133	.127	.123	.119	.116	.114	.111	.108	.106	.104	.102	.100
24	.111	.102	.095	.090	.086	.083	.081	.079	.077	.075	.074	.072	.071	.070
30	.082	.075	.070	.066	.063	.061	.059	.058	.057	.056	.055	.054	.053	.052
36	.068	.063	.059	.056	.054	.052	.051	.050	.049	.048	.047	.046	.045	.044
42	.058	.054	.051	.048	.046	.045	.044	.043	.042	.041	.040	.039	.038	.037
48	.051	.047	.044	.042	.041	.040	.039	.038	.037	.036	.035	.034	.033	.032
54	.045	.042	.040	.038	.037	.036	.035	.034	.033	.032	.031	.030	.029	.028
60	.040	.037	.035	.033	.032	.031	.030	.029	.028	.027	.026	.025	.024	.023
72	.032	.030	.028	.026	.025	.024	.023	.022	.021	.020	.019	.018	.017	.016
84	.026	.024	.022	.021	.020	.019	.018	.017	.016	.015	.014	.013	.012	.011
96	.021	.019	.018	.017	.016	.015	.014	.013	.012	.011	.010	.009	.008	.007
108	.017	.016	.015	.014	.013	.012	.011	.010	.009	.008	.007	.006	.005	.004
120	.014	.013	.012	.011	.010	.009	.008	.007	.006	.005	.004	.003	.002	.001
132	.011	.010	.009	.008	.007	.006	.005	.004	.003	.002	.001	.001	.000	.000
144	.008	.007	.006	.005	.004	.003	.002	.001	.001	.000	.000	.000	.000	.000
156	.006	.005	.004	.003	.002	.001	.001	.000	.000	.000	.000	.000	.000	.000
168	.004	.003	.002	.001	.001	.000	.000	.000	.000	.000	.000	.000	.000	.000
180	.003	.002	.001	.001	.000	.000	.000	.000	.000	.000	.000	.000	.000	.000

<p style="text-align: center;"><b>TABLE 53</b></p> <p style="text-align: center;"><b>STRANDED ALUMINUM WIRE EQUAL IN CONDUCTIVITY TO STRANDED COPPER WIRE</b></p>						
B. & S. Gauge or Circular Mils.		Diameter Bare Cable	Bare	Weight per 1000 ft.		Usual No. of Strands
Copper 97%	Aluminum 61%			D. B. W.	T. B. W.	
1,000,000	1,500,000	1 7/8	1,462	1,958.4	2,670.	61
950,000	1,515,000	1 7/8	1,393	1,860	1,977.	61
900,000	1,431,000	1 7/8	1,317	1,765	1,877.	61
850,000	1,351,500	1 7/8	1,243	1,672	1,779.	61
800,000	1,272,000	1 7/8	1,171	1,581.	1,683.	61
750,000	1,192,500	1 1/2	1,098	1,489.	1,586.	37
700,000	1,113,000	1 1/2	1,025	1,396.	1,489.	37
650,000	1,033,500	1 1/2	950	1,302.	1,390.	37
600,000	954,000	1 1/2	877	1,210.	1,293.	37
550,000	874,500	1 1/2	805	1,119.	1,197.	37
500,000	795,000	1 1/4	732	1,027.	1,100.	37
450,000	715,500	1 1/4	658	937.	994.	37
400,000	636,000	1 1/4	585	836.	896.	37
350,000	556,500	1 1/4	512	739.	772.	19
300,000	477,000	1 1/4	439	614.	657.	19
250,000	397,500	3/4	465	508.	544.	19
200,000	318,000	3/4	392	430.2	459.	7
150,000	238,500	3/4	319.7	345.7	370.	7
100,000	159,000	3/4	247.2	279.	290.	7
50,000	79,500	3/4	174.7	227.	245.	7
1	123,220	1/8	122.6	166.6	178.	7
2	105,530	1/8	97.2	125.2	144.	7
3	87,840	1/8	77	100.	117.	7
4	69,770	1/8	61.2	81.2	96.	7
5	52,530	1/8	48.5	76.5	82.5	7
6	41,740	1/8	38.5	61.5	67.	7

31. THE CORRECTION FOR THE INTERNAL INDUCTANCE OF COPPER CLAD WIRE may be made by the aid of curves given in Figs. 84 to 87. It is seldom necessary to make this correction since the maximum error which may occur is not greater than five percent, but if it is desired, the percentage from the curves may be applied to the constant factor in the formula for inductance, art. 29, Sec. 7.



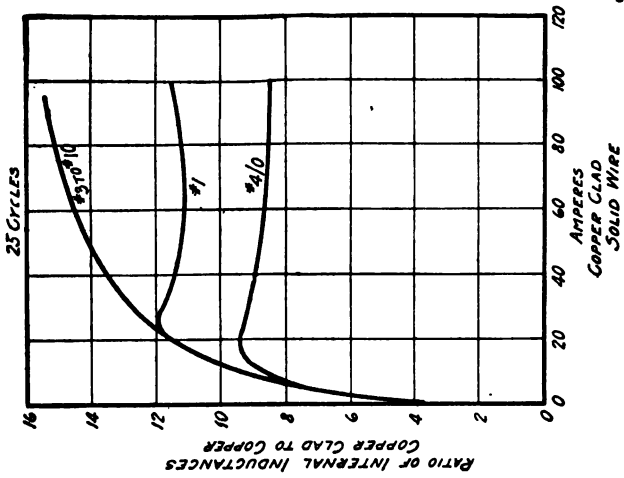

FIG. 85

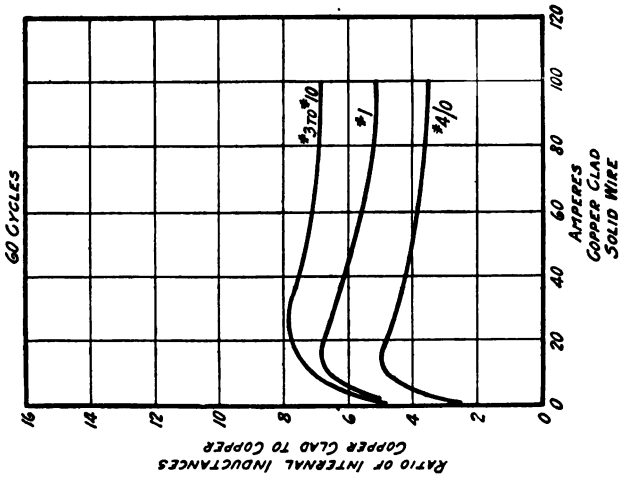

FIG. 84

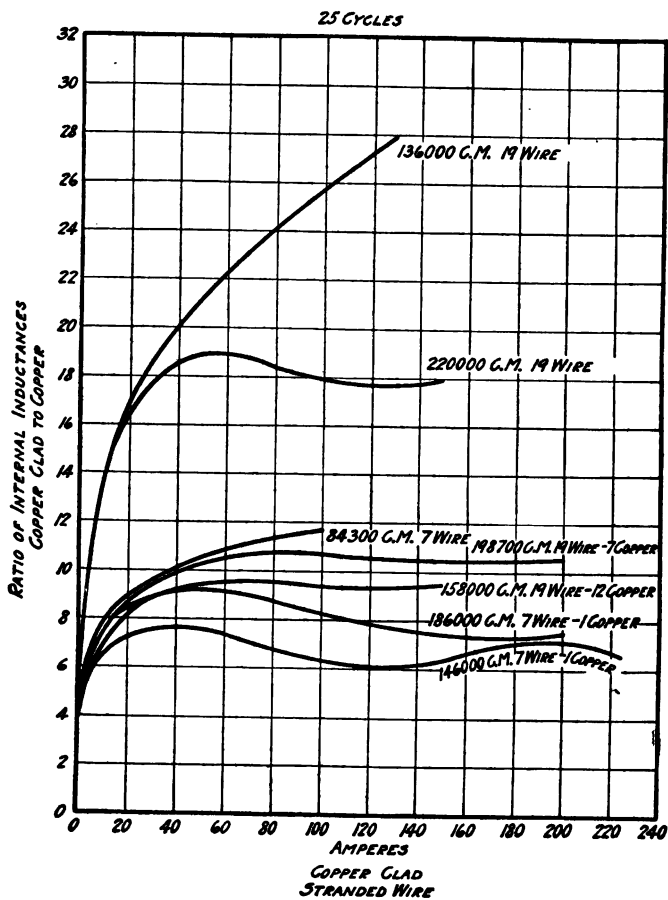

FIG. 86

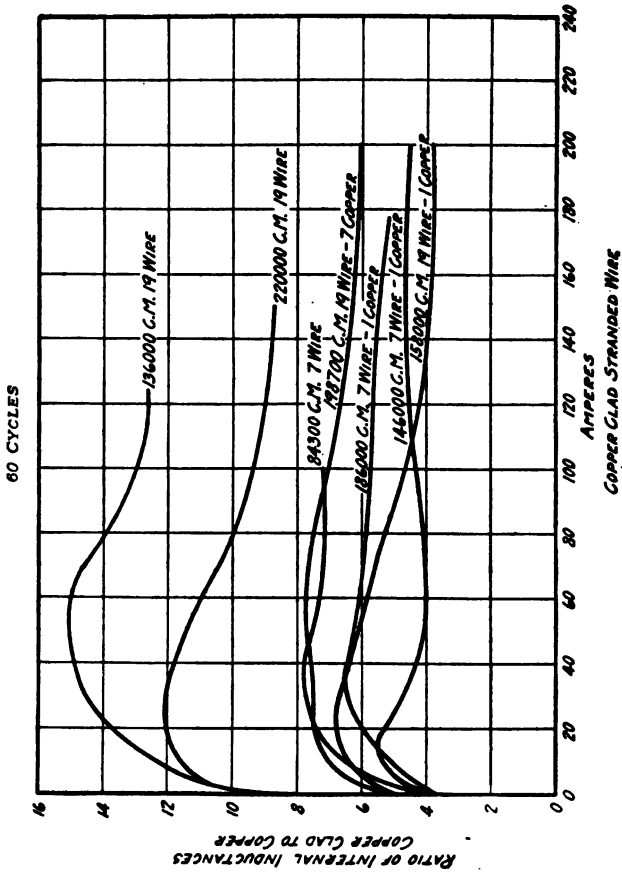

FIG. 87

<p align="center"><b>TABLE 54</b>  <b>AVERAGE TRACK RESISTANCE</b>                      Per 1000 Ft.                      (2 Rails with 20" Bonds)</p>				
Rail Weights lbs. per yd.	30 ft. rails		60 ft. rails	
	1-0000 bonds	2-0000 bonds	1-0000 bonds	2-0000 bonds
45	.01392	.01314	.01314	.01274
50	.01268	.01190	.01190	.01150
55	.01151	.01072	.01072	.01033
60	.01035	.01006	.01006	.00966
65	.01012	.00934	.00934	.00894
70	.009562	.00877	.00877	.00833
75	.009002	.00822	.00822	.00782
80	.008532	.007746	.007746	.00735
85	.008122	.007336	.007336	.00694
90	.007762	.006976	.006976	.00658
95	.007427	.006641	.006641	.006248
100	.007122	.006346	.006346	.005953

**32. SPECIFICATION FOR GALVANIZED STEEL STRAND\***

**¼-Inch, 2300-pound Strand**

This strand shall be composed of seven No. 14 B. W. G. galvanized steel wires and shall be capable of withstanding an ultimate breaking strain of not less than 2300 pounds.

**⅜-inch, 5000-pound Strand**

This strand shall be composed of seven No. 12 B. W. G. galvanized steel wires and shall be capable of withstanding an ultimate breaking strain of not less than 5000 pounds.

Galvanizing. The wires composing a strand shall be galvanized in accordance with the National Electric Light Association standard specification for galvanizing.

**33. SPECIFICATION FOR COPPER WIRES AND CABLES WITH WEATHERPROOF INSULATION\***

**Conductor.** The copper used in all conductors shall have a conductivity of ninety-eight percent of pure copper, Matthiessen's standard. Wire to be soft drawn, having a tensile strength of not less than 34,000 pounds per square inch; shall be uniform in quality, smooth, free from flaws and splinters, and drawn true to gauge.

\*N. E. L. A. specifications.

### Sec. 3 CONDUCTORS AND WIRE TABLES

All solid conductors shall be free from joints. All solid conductors shall be B. & S. gauge. Stranded conductors shall be composed of the number and size of wires called for in this specification.

**Insulation.** Over the copper conductors shall be laid a triple-braided cotton covering; this braiding shall be closely woven and thoroughly saturated with an insulating compound, which shall render it non-absorptive of moisture, and which shall not drip at a temperature lower than 160 degrees Fahrenheit, nor lose its elasticity at 0 degrees Fahrenheit.

The finish of the wires and cables shall present a smooth, hard and even surface.

The finish weight of the various sizes shall be approximately as named below. The permissible variation in the finished weights not to exceed three percent under or over.

SOLID						
Size B. & S.	Weight of Copper, Lbs. per 1000 Feet	Approx. Weight of Insulation, Lbs. per 1000 Feet	Approx. Lbs. per 1000 Feet	Finished Weight Pounds per Mile		
0000	640.5	126	767	4050		
000	506.0	121	629	3320		
00	402.8	99	502	2650		
0	319.5	87	407	2150		
1	253.3	63	316	1670		
2	200.9	59	260	1370		
3	159.3	40	199	1050		
4	126.4	38	164	865		
6	79.5	32	112	500		

STRANDED						
Size	No. of Strands	Size of Each Wire in Mils.	Weight of Bare Cond. Lbs. per 1000 Feet	Weight of Insulation Lbs. per 1000 Feet	Lbs. per 1000 Feet	Finished Weight Pounds per Mile
0000	19	105.5	653	147	800	4226
000	19	94.1	517	136	653	3450
00	19	83.7	410	112	522	2760
0	19	74.6	323	101	424	2240
1	7	109.3	255	73	328	1735

#### 34. SPECIFICATION FOR BARE HARD-DRAWN COPPER WIRE\*

**Material.** The material shall be of copper of such quality and purity that when hard drawn it shall have the properties and characteristics herein required.

\* N. E. L. A. specifications.

**Shapes.** These specifications cover hard-drawn round wire, hard-drawn cable or strand, as hereinafter described.

**Finish.** The wire, in all shapes, must be free from all surface imperfections not consistent with the best commercial practice.

**Packages.** Package sizes for round wire and for cable shall be agreed upon in the placing of individual orders. The wire shall be protected against damage in ordinary handling and shipping.

**Specific Gravity.** For the purpose of calculating weights, cross sections, etc., the specific gravity of copper shall be taken as 8.90.

**Inspection.** All testing and inspection shall be made at the place of manufacture. The manufacturer shall afford the inspector representing the purchaser all reasonable facilities to enable him to satisfy himself that the material conforms to the requirements of these specifications.

**Dimensions and Permissible Variations.** (a) Size shall be expressed as a diameter of the wire in decimal fractions of an inch, using not more than three places of decimals; i. e., in mils.

(b) The wire is expected to be accurate in diameter; permissible variations from nominal diameter shall be:

For wire 0.100 inch in diameter and larger, one percent over or under. For wire less than 0.100 inch in diameter, one mil over or under.

(c) Each coil is to be gauged at three places, one near each end and one approximately at the middle; the coil may be rejected if, two points being within the accepted limits, the third point is off gauge more than two percent in the case of wire 0.064 inch in diameter and larger, or more than three percent in the case of wire less than 0.064 inch in diameter.

**Physical Tests.** The wire shall be so drawn that its tensile strength and the elongation shall be at least equal to the values stated in the following table. Tensile tests shall be made upon fair samples and the elongation shall be determined as the permanent increase in length, due to the breaking of the wire in tension, measured between bench marks placed upon the wire originally 10 inches apart. The fracture shall be between the bench marks and not closer than one inch to either mark. If by testing a sample from any coil of wire the results are found to be below the values stated in the table, tests upon two additional samples shall be made, and the average of the three tests shall determine acceptance or rejection of the coil. For wire whose nominal diameter is between listed sizes, the requirements should be those of the next larger size included in the table.

Electrical conductivity shall be determined upon fair samples by resistance measurements at a temperature of 20 degrees Centigrade (68° F.). The wire shall not exceed the following limits:

For diameters 0.460 inch to 0.325 inch, 900.77 pounds per mile-ohm at 20° C.

For diameters 0.324 inch to 0.040 inch, 910.15 pounds per mile-ohm at 20° C.

Gauge Number	Diameter Inches	Area Cir. Mills	Tensile Strength Lbs. per Sq. In.	Elongation in 10 ins., Per Cent
0000	0.460	211,600	49,000	2.7
000	0.410	168,100	51,000	2.6
00	0.365	133,200	53,000	2.4
0	0.325	105,000	54,500	2.3
1	0.289	83,520	56,000	2.1
2	0.258	66,560	57,500	2.0
3	0.229	52,440	58,500	1.9
4	0.204	41,620	59,500	1.8
5	0.182	33,120	60,500	1.7
6	0.162	26,240	61,500	1.6
7	0.144	20,740	62,500	1.5
8	0.128	16,390	63,400	1.4
9	0.114	12,996	64,200	1.3
10	0.102	10,404	64,900	1.2
11	0.091	8,281	65,400	1.1
12	0.081	6,561	65,700	1.0
13	0.072	5,164	66,000	0.9
14	0.064	4,090	66,200	0.9
15	0.057	3,249	66,400	0.8
16	0.051	2,601	66,600	0.8
17	0.045	2,025	66,800	0.7
18	0.040	1,600	67,000	0.7

#### Hard-drawn Copper wire, Cable or Strand

**Construction.** For the purposes of these specifications, standard cable shall be that made of hard-drawn wire laid concentrically about a hard-drawn wire center. Cable laid up about a hemp center or about a soft wire core is to be subject to special specifications to be agreed upon in individual cases.

**Wire.** The wire entering into the construction of stranded cable shall, before stranding, meet all the requirements of round wire, hereinbefore stated.

**Physical Tests.** The tensile strength of stranded cable shall be at least 90 percent of the total strength required of the wires forming the cable.

**Brazes.** Brazes made in accordance with the best commercial practice will be permitted in wire entering into cable; but no two brazes in wire in the cable may be closer together than fifty feet.

**Lay.** The pitch of a standard cable shall be not less than 12 nor more than 16 diameters of the cable. The cable shall be laid left handed or right handed, as shall be agreed upon in the placing of the individual orders.

#### 35. SPECIFICATION FOR HARD-DRAWN COPPER-CLAD STEEL WIRE\*

**Material.** 1. The material shall be composed of a steel core with a copper coat permanently welded thereto through intervening

\*N. E. L. A. specifications.

layers of copper-iron alloys, and of such quality and purity that when drawn hard it shall have the properties and characteristics herein required.

**Shapes.** 2. These specifications cover hard-drawn copper-clad wire, as hereinafter described.

**Finish.** 3. The wire in all shapes shall be free from all surface imperfections not consistent with the best commercial practice.

**Packages.** 4. (a) Package forms for round wire shall be agreed upon in the placing of individual orders.

(b) Each coil of wire shall be burlapped for protection against damage in ordinary handling and shipping, and shall have the gauge of the wire, weight, etc., approximate length of wire in coil, marked on two tags, one of which shall be attached to the coil inside and the other on the wrapping.

**Inspection.** 5. (a) All testing and inspection shall be made at the place of manufacture. The manufacturer shall afford the inspector representing the purchaser all reasonable facilities to enable him to satisfy himself that the material conforms to the requirements of these specifications.

(b) On orders where no inspection is to be made, the manufacturer shall test ten percent (10%) of all coils for breaking weight and conductivity, and in the event of their conforming with the values stated in the following tables, the material shall be accepted. A copy of these tests shall be furnished when requested.

(c) All orders shall state whether or not inspection is to be made.

**Test of Weld.** 6. The wire when broken by torsion shall show no separation of the copper from the steel.

The wire when broken by repeated bending shall show no separation of the copper from the steel.

The wire when heated to a dull red and quenched in iced water shall show no separation of the copper from the steel.

**Alloy Film.** 7. When properly polished and etched the alloy film shall be distinctly visible under the microscope.

**Dimensions and Permissible Variations.** 8. (a) Size shall be expressed as the diameter of the wire in decimal fractions of an inch, using not more than three places of decimals, i. e., in mils.

(b) The wire is expected to be accurate in diameter; permissible variations from nominal diameter shall be:

For wire 0.200 inches and larger in diameter, one percent (1%) over or under.

For wire 0.200 to 0.100 inches in diameter, one and one-half percent (1½%) over or under.

(c) Each coil is to be gauged at three places, one near each end and one approximately at the middle; the coil may be rejected if, two points being within the accepted limits, the third point is off gauge more than two percent (2%) in the case of wire 0.064 inches in diameter and larger; or more than three percent (3%) in the case of wire less than 0.064 inches in diameter.



### Sec. 3 CONDUCTORS AND WIRE TABLES

**Physical Tests—Breaking Weight.** 9. The wire shall be so drawn that the breaking weight of ninety percent (90%) of the coils tested shall be at least equal to the values stated in the following table, and the remaining ten percent (10%) of the coils shall not be more than five percent (5%) below these values.

Tensile tests shall be made upon fair samples.

If upon testing a sample from any coil of wire the results are found to be below the values stated, tests upon two additional samples shall be made and the average of the three tests shall determine the acceptance or rejection of the coil.

B. & S. Gauge	Diameter in Inches	Breaking Weight
0000	0.460	10,000
000	0.410	8,300
00	0.365	6,850
0	0.325	5,700
1	0.289	4,800
2	0.258	4,000
3	0.229	3,200
4	0.204	2,600
5	0.182	2,200
6	0.162	1,800
7	0.144	1,450
8	0.128	1,200
9	0.114	975
10	0.102	800

**TINNED WIRE.** The breaking weight of tinned wire shall be taken at ninety percent (90%) of the values given above.

**Electrical Conductivity.** Electrical conductivity should be determined upon fair samples by resistance measurements at a temperature of 60 degrees Fahrenheit.

The wire shall not exceed the following limits:

(a) Forty percent (40%) of the conductivity of the same size copper wire. A variation of five percent below this is allowable, i. e., the conductivity of any coil may be as low as thirty-five percent of that of the same size copper wire.

(b) If upon testing a sample from any coil of wire the results are found to be below the values stated, the manufacturer reserves the right to cut back into the coil; the result of this test shall determine the acceptance or rejection of the coil.

**INSULATED WIRE.** All wire to be insulated must be inspected at the place of manufacture for mechanical and electrical tests before insulation, the inspector sealing all coils accepted. This inspection of the conductor to be final; further inspection to be made on the insulation only.

36. SPECIFICATION FOR ALUMINUM WIRES AND CABLES, WEATHERPROOF INSULATION\*.

**Conductor.** Aluminum used in all conductors shall have a conductivity of sixty-two percent of pure copper, Matthiessen's standard; shall have tensile strength of not less than 20,000 pounds per square inch; shall be uniform in quality, smooth, free from flaws and splinters, and drawn true to gauge.

Conductors shall be composed of the number of strands of wire called for in this specification.

Each length of stranded conductor shall be composed of wires without joint.

**Insulation.** Over the aluminum conductors shall be laid a triple-braided jute or cotton covering. This braiding shall be closely woven and thoroughly saturated with an insulating compound which will render it non-absorptive of moisture, and which should not drip at a temperature lower than 160 degrees Fahrenheit, nor lose its elasticity at 0 degrees Fahrenheit.

The finish of the covering shall present a smooth, hard and even surface.

The finished weight of the various sizes shall be approximately as named below. The permissible variation in the finished weights not to exceed three percent under or over.

Aluminum Cir. mils.	Copper Equiv.	No. of Wires	Wt. of Bare Aluminum Pounds per 1000 Feet	Approx. Wt. of Triple Braid Insulation Lbs. per 1000 ft.	Approx. Finished Weight Lbs. per 1000 ft.	Standard Length of Finished Cable Feet
336,420	0000	7	310.2	150	460	5060
266,800	000	7	245.7	124	390	3190
211,950	00	7	195.0	115	390	4020
167,800	0	7	155.0	90	245	5060
133,220	1	7	121.6	55	178	3200
105,530	2	7	97.2	47	144	4040
83,642	2	7	77.0	40	117	2535
66,370	4	7	61.2	37	98	3185

37. SPECIFICATION FOR BARE ALUMINUM WIRE\*

**Material and Construction.** All material used in these cables shall be of the best grade of commercially pure aluminum. It shall consist of strands laid up to form a concentric cable, the lay of the strands being as long as possible consistent with making mechanically good cable, in order to keep the increase of resistance due to stranding as low as possible.

\* N. E. L. A. specifications.

### Sec. 3 CONDUCTORS AND WIRE TABLES

**Strands.** Each strand used in the cable shall be approximately round and true to the calculated diameter within one percent.

**Conductivity.** The average conductivity of the finished strands of the cable shall be not less than sixty-one percent in the Matthiessen's standard scale, as determined by test of the individual strands upon a standard conductivity bridge.

**Tensile Strength.** "The tensile strength of the aluminum shall not be less than 23,000 pounds per square inch nor more than 30,000 pounds per square inch, as determined by tests upon individual strands in a standard tensile testing machine."

**Weight and Stranding.** The weight and area per mile of bare cable shall not vary more than two percent from the following table.

"The following table shows the usual method of stranding aluminum conductors. Variations from this standard stranding are permissible where the conditions make such variation advisable."

Aluminum Conductor Cir. Mils.	Lbs. per M. Feet	No. of Strands
66,370	61.2	7
83,642	77.	7
105,530	97.2	7
133,220	123.6	7
167,800	156.	7
211,950	195.	7
266,800	245.7	7
336,420	319.2	7
397,500	365.	19
477,000	439.	19
556,500	512.	19
636,000	585.	19
715,500	668.	27
795,000	732.	27
874,500	805.	27
954,000	877.	27

**Inspection and Tests.** The purchaser shall have the privilege of inspecting the wire called for on orders, and notification shall be given at least five days prior to the time that the material will be ready for inspection, so that his representative may be present.

The manufacturers are to supply the apparatus necessary to carry out all tests, free of cost to the purchaser. The tests are to be made at one place, and are to be to the satisfaction of the purchaser's representative.

**Connectors.** The manufacturer shall furnish the necessary connectors of a type to be approved by the purchaser.

**38. SPECIFICATION FOR RUBBER INSULATED TREE WIRE BRAIDED\***

**Conductor.** The conductors used shall consist of soft-drawn copper wire, with a conductivity not less than ninety-eight percent of pure copper, Matthiessen's standard, and a tensile strength of not less than 34,000 pounds per square inch.

Conductors of sizes up to and including 0 B. & S. may consist of solid or stranded wire. Conductors of sizes over 0 B. & S. shall consist of stranded cable.

All wires shall be thoroughly tinned.

**Insulation and Covering.** The wire or cable shall be covered with a wall of insulation containing not less than thirty percent best Para rubber, free from substitutes and reclaimed rubber.

The thickness of the rubber insulating wall shall not be less than the following:

No. 6 solid	.....	$\frac{1}{32}$	inch
No. 4 "	.....	$\frac{1}{16}$	"
No. 2 "	.....	$\frac{1}{8}$	"
No. 1 "	.....	$\frac{1}{4}$	"
No. 0 "	.....	$\frac{1}{2}$	"
No. 00 stranded	.....	$\frac{1}{2}$	"
No. 000 "	.....	$\frac{1}{2}$	"
No. 0000 "	.....	$\frac{1}{2}$	"

The rubber insulating wall shall be covered with a drill tape, well filled with rubber, and with a double braided cotton covering. This braided covering shall be closely woven and thoroughly saturated with an insulating compound which shall render it non-absorptive of moisture, and which shall not drip at a lower temperature than 160 degrees Fahrenheit, nor lose its elasticity at 0 degrees Fahrenheit. The braided covering shall be thoroughly slicked down, so that the complete wire or cable shall present a smooth, hard and even surface.

**39. SPECIFICATION FOR CIRCULAR LOOM-COVERED TREE WIRE NO. 6—NO. 4—No. 2\***

**General Description.** The insulation shall adhere strongly to and have the same thickness of wall at all points from the conductor.

The covering shall consist of a double wrap of tape, over which shall be placed a tightly woven cotton yarn thoroughly treated with a preservative compound containing powdered mica.

**Conductor.** The conductor shall be of soft-drawn Lake Superior copper, having a conductivity of not less than ninety-eight percent (98%) Matthiessen's standard, and shall be thoroughly tinned. The conductors No. 6, No. 4 and No. 2 shall be solid American wire gauge.

**Tinning.** All conductors shall be thoroughly and evenly coated with pure tin.

\* N. E. L. A. specifications.

### Sec. 3 CONDUCTORS AND WIRE TABLES

**Insulation.** The insulating wall shall consist of a vulcanized rubber compound of not less than thirty percent by weight of dry, "fine, up-river" Para gum, free from reclaimed rubber, shoddy or rubber substitutes, compounded with from two to three percent by weight of sulphur, not more than three percent of solid waxy hydrocarbons, such as ozokerite or paraffine, and with dry, inorganic mineral matter only as a matrix. The amount of extractive matter contained in the vulcanized compound, as shown by chemical analysis, shall not exceed five percent, of which not more than two percent shall be resinous matter and not more than three percent shall be waxy hydrocarbons.

**Mechanical.** Test pieces cut from the insulating wall must stand stretching not less than ten (10) successive times to two and one-half times their original length before breaking. The portion stretched shall then return within one minute to a length not exceeding 125 per cent of its original length, and a similar sample shall be stretched to three and one-half times its original length without sign of flaw or fracture.

**Electrical.** Each and every length of conductor shall comply with the following table:

Megohms per Mile at 60° F.	Wall of In- sulation (with- out covering)	Outside Diameter OverAll	Voltage Test (at Factory)
No. 6 . . . . 2500	2½/32	.500	5000
No. 4 . . . . 2100	2½/32	.530	4500
No. 2 . . . . 1700	2½/32	.594	4500

**Tests.** The tests shall be made at the works of the manufacturer, before the application of tape, braid or other covering.

Tests shall be made after at least 36 hours' submersion in water and while still immersed. The insulation test shall follow the voltage test, and be made with a battery of suitable electromotive force, and the reading shall be taken after one minute's electrification.

**Tape.** The plain insulation shall be served with a double wrap or rubber-filled cloth tape.

**Woven Covering.** Over the tape shall be placed a covering of tightly woven cotton yarn, thoroughly impregnated with a preservative compound containing powdered mica. This shall be worked into the interstices of the weave and compound, so as to prevent the "flaking off" of the mica surface.

**Tests.** The purchaser shall be allowed the privilege of sending a representative to the works of the manufacturer, who shall be afforded all necessary facilities to make the electrical and mechanical tests, and also assure himself that the specifications are being properly complied with.

**BIBLIOGRAPHY**

**Publications of Various Manufacturers.**

**General Electric Review, 1909.**

**Foster's Electrical Engineers' Pocket Book.**

**N. E. L. A. Report of Committee on Overhead Line Construction,  
1911.**

**U. S. Bureau of Standards, No. 31.**



## **SECTION 4**

### **CROSS-ARMS, PINS AND POLE LINE HARDWARE**





Vertical line on the left side of the page.

Vertical line on the right side of the page.

## SECTION 4

### CROSS-ARMS, PINS AND POLE LINE HARDWARE

#### TABLE OF CONTENTS

	ARTICLE
<b>Cross-arms</b> .....	1
<b>Wood Cross-arms</b> .....	2
Specifications for Untreated Cross-arms .....	3
Specifications for Creosoted Pine Cross-arms .....	4
<b>Steel Cross-arms</b> .....	5
<b>Patent Cross-arms</b> .....	6
<b>Pins</b> .....	7
<b>Standard Pin Threading</b> .....	8
Specification for Wood Insulator Pins .....	9
<b>Combination Wood and Metal Pins</b> .....	10
<b>Metal Pins</b> .....	11
Screw Type .....	12
Cemented Type .....	13
<b>Attaching Pins to Cross-arms</b> .....	14
<b>Line Hardware</b> .....	15
(a) <b>Cross-arm Braces.</b> Specification for Cross-arm Braces.	
(b) <b>Cross-arm Bolts, Carriage Bolts, Lag Screw and Washers.</b> Specification for Cross-arm Bolts, Carriage Bolts, Lag Screws and Washers.	
(c) <b>Pole Steps.</b> Specification for Pole Steps.	
(d) <b>Guy Rods.</b> Specification for Guy Rods.	
(e) <b>Patent Guy Anchors.</b>	



1. **CROSS-ARMS** are generally of wood or steel, although some attempt has been made to manufacture concrete arms, but their use has been so limited and the available data so meager that no information on concrete cross-arms can be given.

2. **WOOD CROSS-ARMS** are usually of long leaf yellow pine, Douglas fir, short leaf yellow pine or Norway pine, although other woods such as oak, spruce, cedar, white pine, loblolly pine and cypress have been used to some extent.

Standard specifications for wood cross-arms have been approved by the National Electric Light Association covering two (2), four (4),

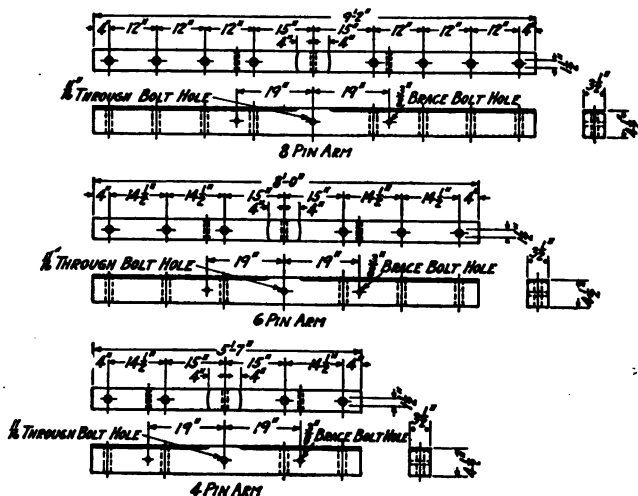

FIG. 88—Standard cross-arms

six (6) and eight (8) pin arms, (Fig. 88) made from Norway pine, yellow pine, cypress or Douglas fir, and are as follows:

### 3. SPECIFICATION FOR UNTREATED CROSS-ARMS.\*

These specifications cover two, four, six, and eight pin painted cross-arms made of Norway pine, yellow pine, cypress or Douglas fir.

Norway pine is understood to cover what is also known as red pine.

\* Standard National Electric Light Association Specification.

Yellow pine is understood to cover what is commonly known as Longleaf pine. It is understood that the term is descriptive of quality rather than of botanical species.

Douglas fir is understood to cover the timber known likewise as yellow fir, red fir, western fir, Washington fir, Oregon or Puget Sound fir or pine, Northwest and West Coast fir.

Cypress is understood to cover the timber known as red cypress.

#### GENERAL

The specifications and drawing Fig. 88 are intended to include all instructions necessary for the manufacturer to guide him in his work. They are intended to co-operate with and supplement each other, so that any details indicated in one and not in the other shall be executed the same as if indicated in both.

#### WORKMANSHIP

All material and workmanship, unless otherwise specified, shall be of the best commercial grade.

#### MATERIAL

**Norway Pine Cross-arms.** All Norway pine cross-arms shall be made of thoroughly air-dried or kiln-dried, straight-grained Norway pine.

**Yellow Pine Cross-arms.** All yellow pine cross-arms shall be made of thoroughly air-dried, or kiln-dried, straight-grained long-leaf yellow pine.

**Cypress Cross-arms.** All cypress cross-arms shall be made of thoroughly air-dried or kiln-dried, straight-grained cypress.

**Fir Cross-arms.** All fir cross-arms shall be made of thoroughly air-dried or kiln-dried, straight-grained Douglas fir.

#### DIMENSIONS

Cross-arms shall be of the style and dimensions shown in Fig. 88. Figures upon the drawing shall be followed in preference to scale measurements.

#### QUALITY

**Pith Heart.** Cypress cross-arms shall be free from pith heart.

**Sapwood.** Cypress cross-arms shall be free from sapwood. Norway pine, yellow pine, and Douglas fir cross-arms may contain sapwood, provided it is clear and does not form over fifteen (15) percent of the cross-section of the cross-arm. Cross-arms shall be shaped so that the sapwood shall be on the top or the sides of the cross-arms.

**Grain.** All cross-arms shall be reasonably straight grained. The grain shall not depart from parallelism to any edge of the cross-arm by an amount greater than one (1) inch to three (3) feet length of cross-arm. All cross-arms shall be out of wind.

**Pitch Pockets.** All cross-arms shall be free from pitch pockets exceeding five (5) inches in length and one-quarter ( $\frac{1}{4}$ ) of an inch in width, and from all pitch pockets which enter the pin or bolt holes on the top or sides of the cross-arm.

**Knots.** All cross-arms shall be free from loose or unsound knots. Eight (8) pin cross-arms shall be free from knots at the third, fourth, fifth and sixth pin holes, and the bolt holes; six (6) pin cross-arms shall be free from knots at the two middle pin holes and the bolt holes.

Eight (8) pin cross-arms may have sound knots not over three-quarter inch in diameter between the third and fourth pin holes, the fourth pin hole and the middle bolt hole, the middle bolt hole and the fifth pin hole, and the fifth and sixth pin holes; six (6) pin cross-arms may have sound knots not over three-quarter inch in diameter between the middle bolt hole and the middle pin holes.

Eight (8) pin cross-arms may contain sound knots, as specified below, outside the third and sixth pin holes; and six pin arms outside of the middle pin holes. Such knots may gradually increase in size from three-quarter inch near the above-mentioned pin holes to one-half the cross-section of the arm at the ends.

**Wane.** All cross-arms shall be free from wane.

**Shakes.** All cross-arms shall be free from through shakes, and from other shakes or checks exceeding three (3) inches in length.

**Warp.** A straight edge laid lengthwise on the concave side of an eight (8) pin or a six (6) pin cross-arm shall not show an offset greater than one (1) inch on the eight (8) pin cross-arm and greater than three-quarters ( $\frac{3}{4}$ ) of an inch on the six-pin cross-arm. No cross-arm shall be twisted or bent in more than one direction or bent in one direction on edge.

**Loose Heart.** All cross-arms shall be free from loose hearts.

**Rot.** All cross-arms shall be free from rot, dote or red heart.

**Worm Holes.** All cross-arms shall be free from worm holes.

### INSPECTION

All cross-arms shall be inspected for dimensions and defects outlined under "Quality" before painting.

The spacing of the pin and bolt holes shall be within the limits shown in Fig. 88.

Pin and bolt holes shall be tested with steel gauges and shall take gauges as follows:

Pin holes	$1\frac{1}{2}$ -inch gauge without forcing but not a $1\frac{1}{4}$ -inch gauge.
Middle bolt hole	$\frac{5}{8}$ -inch gauge, without forcing
Brace bolt holes	$\frac{3}{8}$ -inch gauge, without forcing

All cross-arms not conforming to these requirements shall be rejected.

The pin and bolt holes shall be smooth and the arms shall not be badly splintered where the bits have broken through.

The brace bolt holes shall not be drilled through the pin holes.

#### STORAGE

After the cross-arms are shaped they shall be stacked in cross-piles on skids in such a manner as to insure good ventilation. The stacks shall be roofed to prevent the penetration of rain, or the direct action of the sun.

#### 4. SPECIFICATION FOR CREOSOTED PINE CROSS-ARMS.\*

**Material.** All cross-arms shall be made from sound, straight-grained, short leaf or loblolly pine.

**Quality.** All cross-arms shall be free from loose or unsound knots over three-quarters ( $\frac{3}{4}$ ) of an inch in diameter. They shall be free from loose hearts, rot, dot, red heart, worm holes, shakes or excessive wane or pitch pockets.

**Workmanship.** All material and workmanship shall be of the best commercial grade.

**Storing.** If the cross-arms are to be stored by the manufacturer, they shall be so stacked in cross piles on skids as to insure good ventilation and shall be roofed to exclude sun and rain.

**Dimensions.** All cross-arms shall be of the style and of the dimensions shown in drawing (Fig. 88), which drawing forms a part of this specification.

**Creosoting** shall comply with the specification for creosoting in Section 9, article 14.

**5. STEEL CROSS-ARMS** are usually of angle or channel section. Such arms have not been standardized. Their length, the location of the pin holes and bolt holes are dependent upon the conductor spacing, the conductor arrangement which it is proposed to use, and upon the method by which the arm is to be attached to the pole.

**6. SPECIAL CROSS-ARMS** constructed of malleable iron, pipe fittings and various steel sections are available, two of which are illustrated in Figs. 89 and 90. Such cross-arms are manufactured for different conductor separations.

**7. PINS** may be divided into three general classes:

- (a) All wood pins;
- (b) Combinations of steel, wood and porcelain pins;
- (c) All metal pins.

Wood, as a structural material for use in supporting line insulators, has for many years been regarded as desirable. It is cheap, easily fabricated and in some slight degree adds to the insulator strength.

---

\* From 1911 Report of the Committee for the Preservative Treatment of Wood Poles and Cross-arms.

A properly impregnated pin of generous design is generally satisfactory, except when used on higher potential systems. The fault with wood pins lies in the danger of burning or digesting of that portion of the pin adjacent to the insulator. At the threaded por-

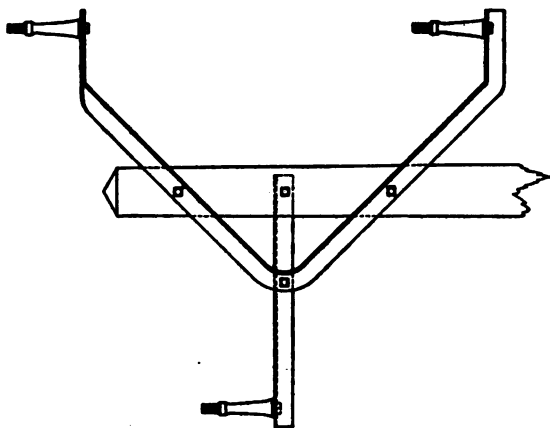

FIG. 90.—Special cross-arm.

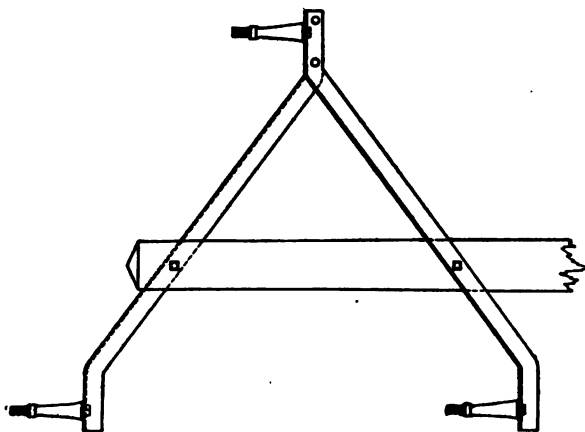

FIG. 89.—Special cross-arm.

tion, the wood pin is of smallest cross-section, and being thoroughly dry at this point, the resistance to leakage or capacity current flow is greatest. Also the electrostatic flux density is greatest at the



point of least cross-section, so that burning or digesting of the pin may occur. Metal pins entirely relieve the burning and digesting difficulty and also provide greater mechanical strength.

In general, wood pins used in connection with insulators of very high factors of safety, in climates not affected by salt fogs or chemical fumes are reasonably satisfactory.

Solid steel or iron pins are not as desirable as those pins which include some form of separable thimble, that can be economically and properly cemented into the insulator at the factory and in turn screwed on to the pin body erected on the poles or towers. Probably the greatest benefit of this form of construction is the ease with which broken insulators can be replaced.

**8. STANDARD PIN THREADING.** The standard pitch for pin and pinhole threading is 4 threads per inch and the standard diameters are 1" (standard pinhole) and 1 $\frac{3}{8}$ " (large pinhole). These diameters are the extreme diameters at the top of the pin and at the bottom of the pinhole as illustrated (Fig. 91). The

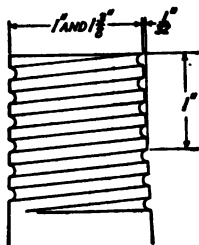

FIG. 91.—Standard pin threads.

standard taper for the diameters of pins and pinholes is  $\frac{1}{8}$ " increase in diameter per 1" in length.

The National Electric Light Association standard wood pin is illustrated in Fig. 92, specifications for which follow:

#### 9. SPECIFICATION FOR WOOD INSULATOR PINS.\*

The quality of the materials used and the methods of manufacture, handling and shipment shall be such as to insure for the finished pins the properties and finish called for in these specifications. The manufacturer must make sure that all materials and work are in accordance with the specifications before the pins are delivered. The purchasing company is to have the right to make such inspections and tests as it may desire, of the materials and of the pins at any stage of the manufacture, such inspections not to include the inspection of the processes of manufacture. The inspector of the

\* Standard National Electric Light Association Specification.

purchasing company shall have the power to reject any pin which fails to satisfy the requirements of these specifications. Inspection shall not, however, relieve the manufacturer from the obligation of furnishing satisfactory material and sound, reliable work.

Any unfaithful work or failure to satisfy the requirements of these specifications that may be discovered by the purchasing company on or before the receipt of the finished pins shall be corrected

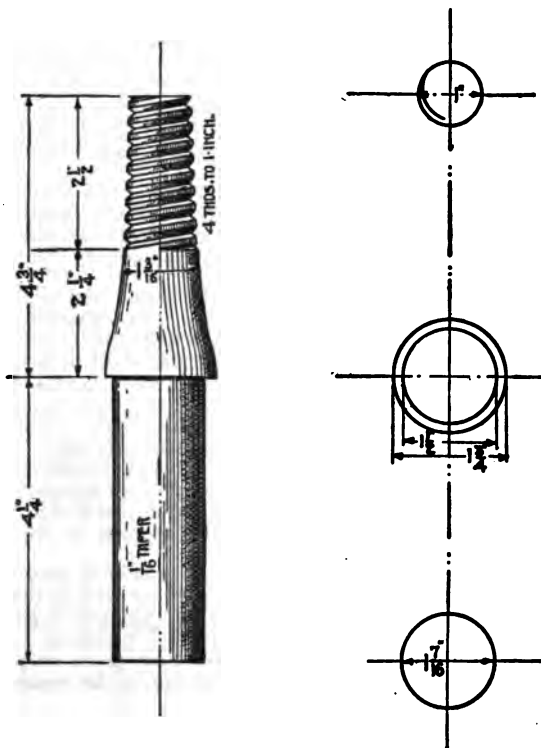

FIG. 92.—Standard N. E. L. A. wood pin.

immediately upon the requirement of the purchasing company, notwithstanding that it may have been overlooked by the inspector.

**General.** These specifications cover the manufacture of standard locust pins as ordered.

The drawings and specifications are intended to include all in-

structions necessary for the manufacturer to guide him in his work. They are intended to co-operate with and supplement each other, so that any details indicated in one and not in the other shall be executed the same as if indicated in both.

Figures upon the drawing shall be followed in preference to scale measurements.

All material and workmanship, unless otherwise specified herein, shall be of the best grade.

**Material.** All pins shall be made of sound, straight grained yellow or black locust, free from knots, checks, sapwood, worm holes, braash wood, cracks or other defects, except as hereinafter specified.

**Knots.** The pins shall be free from large, loose or unsound knots. Small knots not over one-eighth ( $\frac{1}{8}$ ) of an inch in diameter are allowable on the shoulder and on the lower half of the shank of the pin.

**Checks.** Small season checks are allowable on the shoulder and on the lower half of the shank of the pin. The number of such pins shall not exceed five (5) percent of the number furnished.

**Sapwood.** Sapwood is allowable on the shoulder of the pin provided it does not extend to the shank.

**Worm Holes.** If the wood is otherwise sound, worm holes are allowable on the lower third of the shank. The number of such pins shall not exceed five (5) percent of the number furnished.

**Finish.** The grain of the wood on all pins shall be reasonably parallel to the axis of the pin. The grain through the center of the bottom of the pin shall not run out below the bottom thread.

**Seasoned Pins.** All seasoned pins shall have four (4) threads to the inch, and the dimensions shown on drawing, Fig. 92.

The threads shall be smooth and of uniform pitch, and such that a standard insulator can be readily screwed on to a standard pin, until the end of the pin touches the top of the insulator and, when in this position, there shall be no perceptible rocking or play of the insulator on the pin.

The pins shall be as nearly as possible of a circular cross-section.

Flat surfaces not over one-eighth ( $\frac{1}{8}$ ) of an inch in depth are allowable on the shoulders of the pins; the number of such pins shall not exceed five (5) percent of the number furnished.

**Unseasoned Pins.** Pins manufactured from green or partially seasoned wood shall, when seasoned, conform to the requirements above specified for seasoned pins.

**10. COMBINATION WOOD, PORCELAIN AND METAL PINS,** are usually made by using a wood top, a wood and porcelain top, or a metal and porcelain top and a steel through bolt as illustrated in Figs. 94-95.

**11. METAL PINS.** The construction of metal pins varies in the manner in which the insulator is attached to the pin and the manner in which the pin is attached to the crossarm. Insulators may be attached to the pin by either of two methods:



FIG. 93.—Wood or solid metal pin.



FIG. 94.—Wood, steel, through bolt pin.



FIG. 95.—Porcelain base wood top pin.

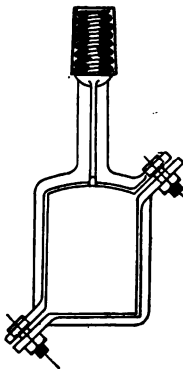

FIG. 96.—Clamp pin, solid metal split head, with felt insertion.

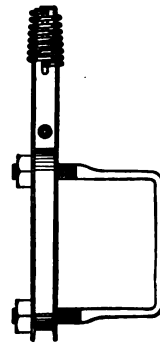
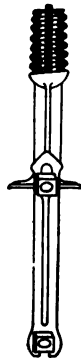

FIG. 97.—Wire screw thread, clamp pin.

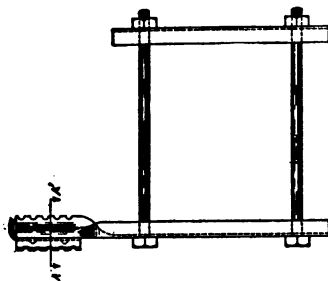

Fig. 98.—Clamp pin, with flexible metal stamped thread.

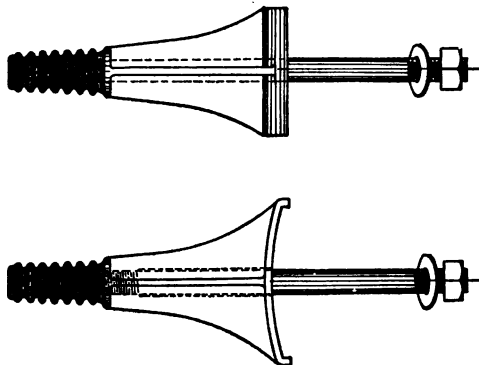

Fig. 99.—Solid metal pin, with separable thimble.

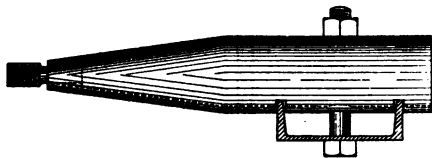

Fig. 100.—Swedged pipe pin, separable thimble.

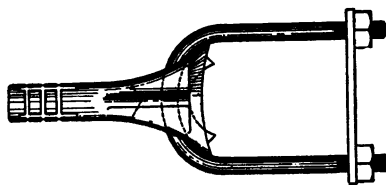

Fig. 101.—Solid metal clamp pin.

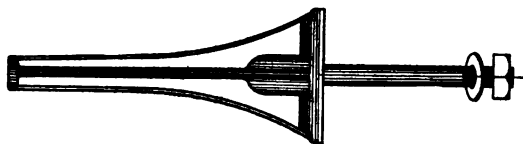

FIG. 105.—Solid metal pin.

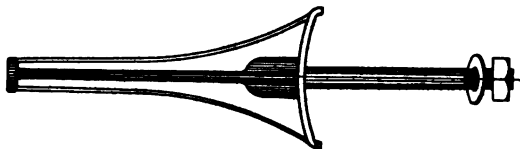

FIG. 104.—Pressed steel pin with separable thimble.

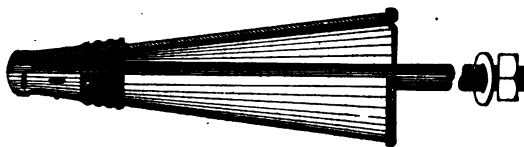

FIG. 103.—Hollow metal pin with separable thimble.

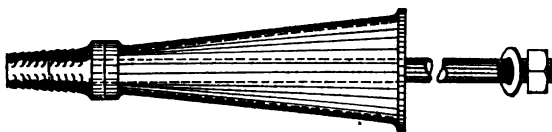
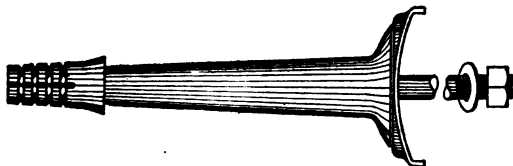

FIG. 102.—Forged pin with separable thimble.



## Sec. 4

## CROSS-ARMS, PINS, ETC.

(a) The screw type in which the insulator is screwed on to the pin. (Art. 12.)

(b) The cemented type in which the insulator is cemented to the pin or a detachable portion of the pin. (Art. 13.)

**12. SCREW TYPE.** The designs of screw threads vary. A number of types are as follows:

**1st.** The solid metal pin (Fig. 93) because of the unequal expansion and contraction of the pin and the insulator, may cause failure of the insulator. When such pins are used it is customary to wrap the pin with a few layers of tape thus providing a cushion to relieve the stresses.

**2nd.** The solid metal pin in which the head is split (Fig. 96) and a piece of felt inserted, in order to relieve the unequal expansion and contraction stresses.

**3rd.** The spiral spring (Fig. 97) in which the stresses, due to the unequal expansion and contraction, are relieved by the lengthening or shortening of the spring, which slowly twists around in the insulator.

**4th.** The flexible stamped thread (Fig. 98) consisting of a solid pin on which is riveted a steel saw tooth shaped flexible stamping, which allows for the unequal expansion and contraction of the insulator and pin. A flat spring over the top of the solid part of the pin prevents breakage of the insulator when installing.

**13. CEMENTED TYPE.** Pins to which insulators are cemented are of two general classes:

(a) Pins to which the insulator is directly cemented (Figs. 101 and 105.)

(b) Pins with separable thimbles, the thimble only being cemented into the insulator. (Figs. 99, 100, 102, 103, 104.)

The latter are the types generally used, as the former necessitate the removal of the pin when changing the insulator.

**14. ATTACHING PINS TO CROSS-ARMS.** Pins may be attached to the cross-arms by three methods:

(a) A driving fit, (Fig. 93) in which the tapered pin shank is driven into a hole in the cross-arm. This type is generally used in connection with wood cross-arms and is usually confined to all wood pins. Where so used, a nail is driven through the cross-arm and the pin in order to secure the pin in position.

(b) Bolted type (Figs. 94, 95, 99, 100, 102, 103, 104, 105) in which the pin is fastened to the cross-arm by means of a through bolt.

(c) The clamp pin (Figs. 96, 97, 98, 101) in which the pin is so constructed that the cross-arm is girdled and the pin clamped into position.

## 15. LINE HARDWARE

(a) **Cross-arm Braces** may be either of flat bar or angle section. For ordinary distribution work flat bar braces are generally used.

The standard section of steel bar braces is  $1\frac{1}{4}'' \times \frac{1}{4}''$ ; the length from 20'' to 32''. Angle iron braces in one piece, as illustrated in Fig. 106 have been used to some extent in wood pole work. The standard National Electric Light Association 28'' brace is illustrated in Fig. 107, specification for which follow:

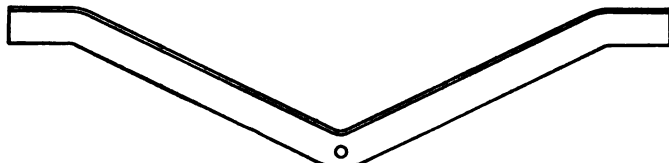

FIG. 106. Angle iron cross-arm brace.

#### SPECIFICATIONS FOR CROSS-ARM BRACES.\*

**Workmanship.** All material and workmanship shall be of the best grade.

**Material.** All braces shall be made of iron or mild steel, "Manufacturers' Standard," galvanized or sherardized, as provided in The National Electric Light Association standard specification for galvanizing or sherardizing.

The holes in the braces shall be clear and free from superfluous zinc.

**Dimensions.** All braces shall be made in accordance with the dimensions shown in drawing, Fig. 107.

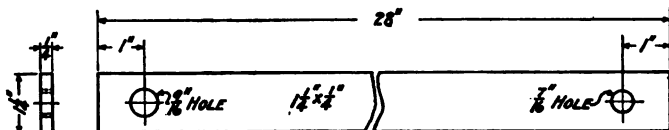

FIG. 107. Standard N. E. L. A. Cross-arm brace.

#### (b) Cross-arm Bolts, Carriage Bolts, Lag Screws and Washers.

The National Electric Light Association standard cross-arm bolts, carriage bolts, lag screws and washers are illustrated in Fig. 96, specification for which follows:

#### SPECIFICATION FOR CROSS-ARM BOLTS, CARRIAGE BOLTS, LAG SCREWS AND WASHERS.\*

This specification covers bolts with cut thread only, which must be furnished unless specific instructions are given otherwise. Lag

\* Standard National Electric Light Association Specification.



CROSS-ARMS, PINS, ETC.

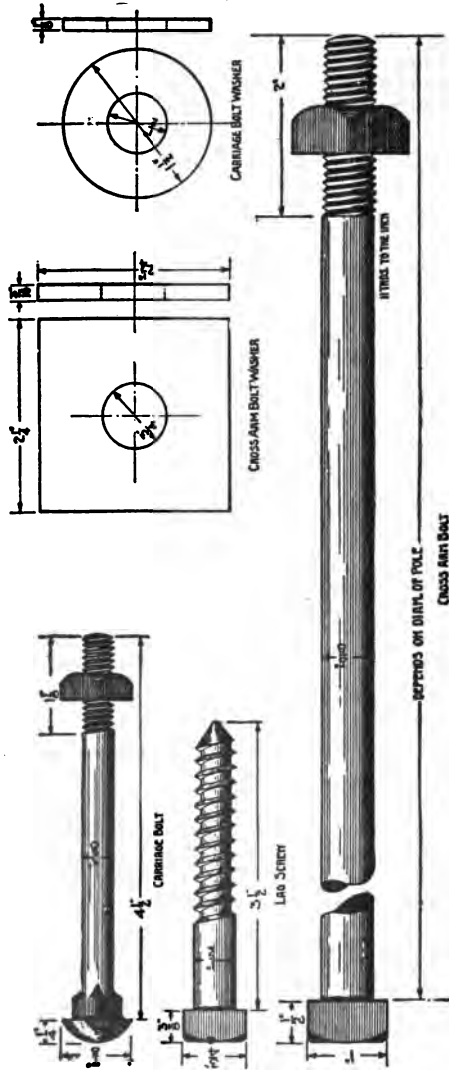

FIG. 108.—Standard cross-arm bolt, lag bolt, carriage bolt and washers.

screws can be furnished with either fetter or twist threads, unless either one is particularly specified.

The materials and styles called for are intended to be stock materials and sizes. Should the detail dimensions conflict with standard sizes, the manufacturer should state wherein the differences exist, but in all cases the mechanical requirements must conform.

**Workmanship.** All material and workmanship specified herein shall be of the best grade.

**Material.** Cross-arm bolts, carriage bolts, lag screws and washers shall be made of iron or mild steel, "Manufacturers' Standard," and shall be galvanized or sherardized in accordance with the National Electric Light Association standard specification for galvanizing or sherardizing.

**Dimensions.** The dimensions of this material shall be in accordance with drawing, Fig. 108.

**Finish.** All bolts must be free from badly formed or otherwise defective heads. The heads of the bolts must be rounded or chamfered. The threads must be full and clean and concentric with the axis of the bolts.

All nuts must be symmetrically formed and must have the hole centrally located. The axis of the threads must be perpendicular to the face of the nut. All nuts must be an easy fit for the bolt, so that the nut can be run the entire length of the thread without undue forcing with the fingers.

All washers must be symmetrically formed and have the holes centrally located.

Bolt heads, nuts, etc., shall be of sufficient strength to develop the ultimate strength of the bolt shank.

**Galvanizing.** All galvanizing or sherardizing shall be in accordance with the National Electric Light Association standard specification for galvanizing or sherardizing.

A coating of zinc shall be left on the threads of the bolts conforming in all respects with the said specifications for galvanizing or sherardizing.

The threads of the nuts need not be galvanized.

The holes in the washers shall be clean and free from superfluous zinc.

The galvanizing shall not be chipped off when washers have stuck together.

---

(c) **Pole Steps.** The standard National Electric Light Association wood pole step is illustrated in Fig. 109, specifications for which follow:

#### SPECIFICATION FOR POLE STEPS\*

**Workmanship.** All material and workmanship shall be of the best grade.

---

\* Standard National Electric Light Association Specifications.

**Material.** All pole steps shall be made of iron or mild steel, "Manufacturers' Standard," galvanized or sherardized in accordance with the National Electric Light Association standard specification for galvanizing or sherardizing.

**Dimensions.** All pole steps shall be made in accordance with the dimensions shown in drawing, Fig. 109.

**Mechanical Requirements.** When rigidly held by the head, the pole step shall be capable of being bent through an angle of 90 degrees, about a diameter equal to the diameter of the pole step, without breaking.

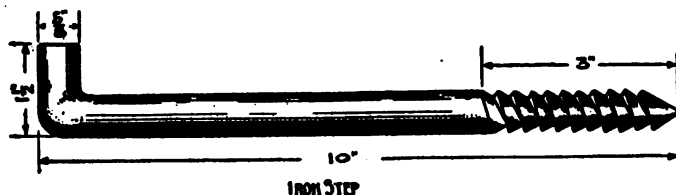

FIG. 109.—Standard pole step.

(d) **Guy Rods.** The standard National Electric Light Association guy rods are illustrated in Fig. 110, specification for which follows:

#### SPECIFICATION FOR GUY RODS\*

This specification covers the construction of a standard guy rod.

**Workmanship.** All material and workmanship shall be of the best grade.

**Material.** All guys rods shall be made of iron or mild steel, "Manufacturers' Standard," galvanized or sherardized.

**Dimensions.** All guy rods shall be made in accordance with the drawing shown in Fig. 110.

**Finish.** The welded joints shall be of the best workmanship, thoroughly welded without being overheated.

The threads on the bolts shall be full and clean and concentric with the axis of the rod. The thread end of the rod shall be rounded or chamfered.

All nuts shall be symmetrically formed and shall have holes centrally located.

The axis of the threads shall be reasonably perpendicular to the face of the nut. All nuts must be an easy fit for the bolt, so that the nut can be run the entire length of the thread without undue forcing with the fingers.

\* Standard National Electric Light Association Specification.

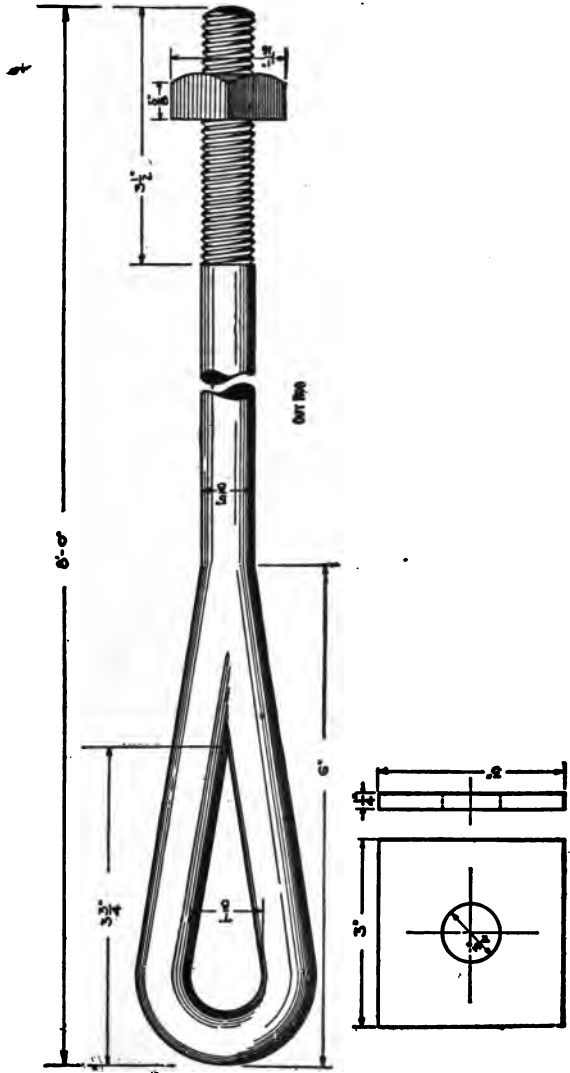

FIG. 110.—Standard guy rod and washer.

## Sec. 4

## CROSS-ARMS, PINS, ETC.

All washers must be symmetrically formed and have the holes centrally located.

**Mechanical Requirements.** The strength of the eye, nut and thread shall be sufficient to develop the ultimate strength of the rod.

**Galvanizing.** All galvanizing or sherardizing shall be done in accordance with the National Electric Light Association standard specification for galvanizing or sherardizing. A coating of zinc shall be left on the threads of the rods. The threads of the nuts need not be galvanized.

(e) **Patent Guy Anchors.** There are a number of different designs on the market. Among them are the screw type, the scoop or flat expanding plate type, the straight malleable-iron plate deadman and various kinds of harpoon-like designs.

The screw type is set in the ground by means of a special wrench and requires no digging in its installation.

The scoop and the expanding types of anchors require the digging of holes of small diameter with an earth auger.

The expanding types are placed in straight auger holes and then by hammering a shoulder or lug with a tamping bar, multiple discs or arms are projected into the walls of the hole.

The value of a patent guy anchor in any particular soil is dependent upon the effective bearing area that it possesses. Where guys supporting excessive strains are used, the deadman or anchor log type will usually prove the more satisfactory.

(f) **Pole Brackets.** The number of designs of pole brackets are so numerous and their selection is so dependent upon the type of construction adopted, that illustrations or descriptions to be of any value require considerable space. In general, such brackets should be carefully selected with respect to strength and stability of construction, and should be galvanized or sherardized in accordance with the National Electric Light Association specification for galvanizing or sherardizing.

## BIBLIOGRAPHY

N. E. L. A. Overhead Line Construction Committee, 1911.  
Publications of various manufacturers.

**SECTION 5**

**INSULATORS**



## SECTION 5

### INSULATORS

---

#### TABLE OF CONTENTS

	ARTICLE
<b>General</b> .....	1
<b>Porcelain</b> .....	2
Wet Process .....	3
Dry Process .....	4
Glazing and Firing .....	5
Relative Advantage of the Wet and Dry Processes .....	6
The Properties of Insulator Glazing .....	7
<b>Glass Insulators</b> .....	8
<b>The Cementing Together of Built up Insulators</b> .....	9
<b>Composition Insulators</b> .....	10
<b>The Effect of Mechanical Stress on Insulators</b> .....	11
<b>The Effect of Different Types of Pins on Insulator     Characteristics</b> .....	12
<b>Electrical Characteristics</b> .....	13
<b>Ageing of Insulators</b> .....	14
<b>Testing Insulators</b> .....	15
<b>Insulator Tests</b> .....	16
Elimination Tests on Pin Type Insulators .....	17
Elimination Tests on Suspension Type Insulators .....	18
Dry Arc-over Test on Pin Type Insulators .....	19
Dry Arc-over Tests on Suspension Type Insulators .....	20
Rain Arc-over Tests on Pin Type Insulators .....	21
Rain Arc-over Tests on Suspension Type Insulators .....	22
Mechanical Test on Pin Type Insulators .....	23
Mechanical Tests on Suspension Type Insulators .....	24
Puncture Tests .....	25
Method of Measuring Test Voltage .....	26
<b>Insulator Protection</b> .....	27
<b>Voltage Distribution on the Suspension Insulator String</b> .....	28
Effect of Leakage .....	29
Capacity of Insulator String .....	30
Effect of Capacity .....	31
Calculated Characteristics .....	32
<b>Grading the Capacity of Insulators</b> .....	33





1. **General.** Insulators may be divided into three general classes:

- (A) Pin type.
- (B) Suspension type.
- (C) Strain type.

The first two types are made of porcelain, glass or composition and the third of porcelain, glass, composition and wood.

**Pin** type insulators are of a pedestal form and designed to carry the wire above the cross arms or structure support.

**Suspension** and **Strain** insulators are similar in type; so designed that the maximum mechanical stress is applied along the axis of the insulator and not at right angle thereto, as in the pin type insulator.



FIG. 111.—Porcelain pin type insulator, line voltage 70,000 volts.



FIG. 112.—Porcelain pin type insulator, line voltage 45,000 volts.

2. **PORCELAIN** insulators are made from clays. The clays are formed from decomposed feldspar and granites, and may be divided into two main classes:

- (a) Residual, or clay found in the localities in which it was formed.
- (b) Sedimentary, or clay that has been transported by water and deposited in beds.

Clays vary in their chemical, mechanical, electrical and workable characteristics, depending upon the localities from which they are secured. Insulator manufacturers combine the various clays, each making a special mixture in order to conform to their particular method of manufacture and to some extent varying the mixture, depending upon whether the clay is to be used in the wet or dry process of manufacture.

The mixing of the clay is a mechanical process in which great care is taken to thoroughly mix the compound in order to be assured of a uniform product. The mixture is put through a number of processes until a plastic thoroughly mixed compound is produced.

The actual manufacture of porcelain insulators can be divided into two classes:

- (a) The wet process. (Art. 3.)
- (b) The dry process. (Art. 4.)

INSULATORS

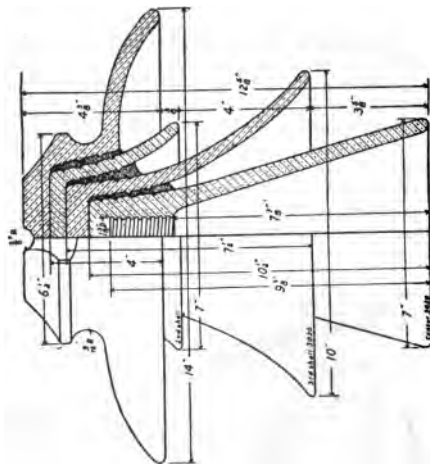

Fig. 114.—Porcelain pin type insulator, line voltage 60,000 volts.

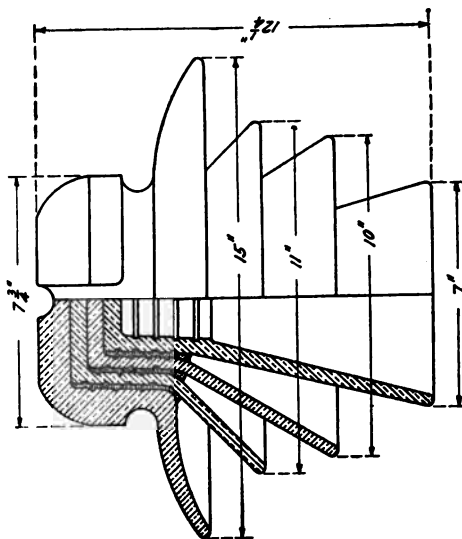

Fig. 113.—Porcelain pin type insulator, line voltage, 50,000 volts.

**3. Wet Process.** In the manufacture of insulators by the wet process the plastic clay is worked into a mould, care being taken to completely fill all the cavities in the mould. The inside of the piece is formed by a plunger. Some manufacturers revolve the mould and others the plunger.

All the higher voltage insulator parts are made in this manner except that in the manufacture of very small insulators, the plunger is so designed that it also forms the inside thread of the insulator.

The moulds containing the partially formed insulators are then placed in a drying room where, when partially dried, the mould is removed and then the piece is allowed to become bone dry. This bone dry piece is placed on a revolving mandrel and its surface is scraped and finished. The parts that come in contact with the

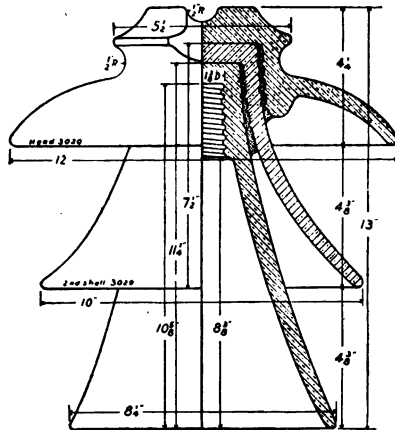

FIG. 115.—Porcelain pin type insulator, line voltage 44,000 volts.

cement and also the side wire groove are turned, after which the insulator is ready for glazing and firing.

**4. Dry Process.** In the manufacture of insulators by the dry process the mixture of clay is different from that used in the wet process. After thoroughly mixing, it is allowed to become dry. It is then crushed into a fine powder and pressed into shape in a steel mould. The mass is removed and when it has become bone dry, it is ready for glazing and firing.

**5. Glazing and Firing.** Insulators are glazed by dipping the formed clay into a glazing solution, protecting the surfaces which are to be left unglazed, from the solution. Different glazing materials are necessary for different colored glazing. Three colors are generally used, white, brown and blue or slate color. White glaze

## Sec. 5

## INSULATORS

is made of the same material as the body of the piece with an extra fine quality of flux, *i.e.*, feldspar. Brown glaze is a pure earthy matter in suspension, manganese oxide and iron oxide being sometimes used. Blue or slate colored glazes may be secured by use of cobalt oxide. The pieces which have been dipped in the proper glazing

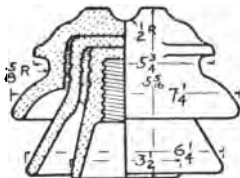

FIG. 116.—Porcelain pin type insulator, line voltage 25,000 volts.

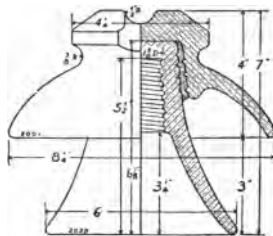

FIG. 117.—Porcelain pin type insulator, line voltage 22,000 volts.

solution are then packed and fired in kilns, in which the insulators are so arranged that they are protected from direct contact with the fire.

Proper firing requires from 40 to 48 hours and necessitates constant attention, in order that the insulators or parts shall not be over or under fired. After proper firing of the insulators or insulator

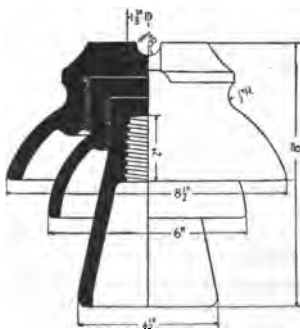

FIG. 118.—Glass pin type insulator, line voltage 25,000 volts.

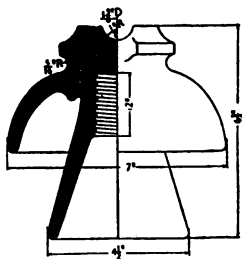

FIG. 119.—Glass pin type insulator, line voltage 20,000 volts.

parts, they are allowed to cool slowly and are then sorted to eliminate pieces having visible flaws.

**6. Relative Advantage of the Wet and Dry Processes.** Where high voltage test requirements must be met, insulators made by the wet process should be used, as the body is dense, homogeneous

and uniform. Porcelain insulators made by the dry process do not possess these features to as great an extent and are, therefore, less dependable and should only be used on comparatively low voltage installations.

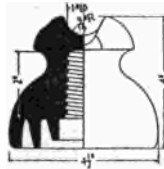

FIG. 120.—Glass pin type insulator, line voltage 10,000 volts.

**7. The Properties of Insulator Glazing.** Insofar as most commercial forms of insulators are concerned, the **glaze adds practically nothing to the dielectric strength**, its prime use being to keep the insulator clean and to present a smooth glossy surface, which tends to prevent the permanent adherence of dust.

All glazes which have colors contain **metallic oxides**, and even some of the transparent glazes have a large percentage of metallic oxide in the form of lead, zinc, tin, manganese, iron or cobalt. All of these can be used with success in insulator glazes, and are used



FIG. 121.—Composition pin type insulator, line voltage 38,000 volts.

by all of the manufacturers to a large extent. The brown glazes owe their coloring to iron and manganese oxide.

The **puncture value is practically independent of the material used in glazing**. The glaze is essentially glass and, therefore, has the same mechanical characteristics as glass.

**8. GLASS INSULATORS.** Glass for insulators is manufactured from sand, lime and soda ash, which materials when properly mixed are melted in a furnace at a temperature of about 2600° F. The materials, as they become completely melted are in the form of a clear liquid glass, which has a plastic nature. The mass is pressed into a mould of proper form where it is allowed to cool, after which it is removed to an annealing oven and thoroughly annealed. When the insulators are removed from the annealing oven,

Sec. 5

INSULATORS

they are allowed to stand in the open air for about one month. Then they are sorted and tested.

9. THE CEMENTING TOGETHER OF BUILT UP INSULATORS. Porcelain and glass insulators particularly of the

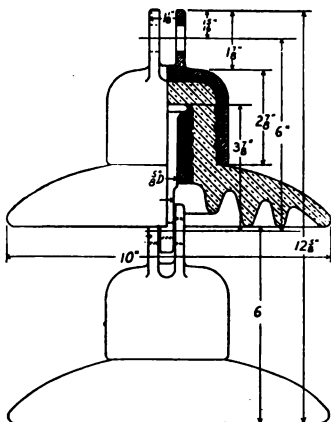

FIG. 122.—Porcelain suspension type insulators.



FIG. 123.—Porcelain suspension insulator string for 100,000 volts.

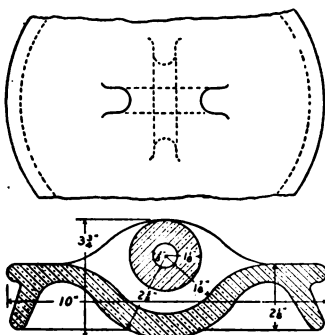

FIG. 124.—Porcelain suspension type insulator.

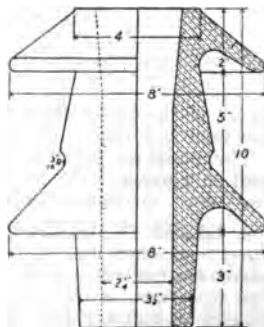

FIG. 125.—Porcelain through pin type insulator, line voltage 23,000 volts.

higher voltage type are made up of a number of pieces, the proper cementing together of which necessarily is of great importance. Portland Cement is chiefly used. Other cements are available, the principal ones of which are Sulphur, Condensite and Plaster of Paris. When using cement, pure Portland Cement of the best

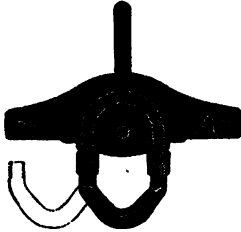

FIG. 126.—Composition suspension type insulator.



FIG. 127.—Porcelain suspension type insulators.

quality without any other ingredients is desirable in order to be assured of good mechanical strength. Compared to porcelain, cement is a good electrical conductor and therefore acts to a greater or less extent as a conducting condenser plate between the two insulator parts which it connects.

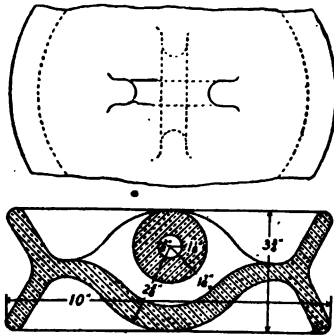

FIG. 128.—Porcelain strain insulators.

Condensite seems to be the most successful cement that can be used for cementing together parts of glass insulators and while it has good electrical characteristics, it is very expensive.

Sulphur is good mechanically and electrically, but it has a low melting point and, if the insulator heats slightly, the sulphur will melt, causing mechanical failures.



Plaster of Paris is comparatively mechanically weak and therefore seldom used.

Care should be taken to use a cement which does not act chemically on the metal parts,—for instance, producing an oxide on their surface thus enlarging them and producing stresses which may cause the porcelain to crack.

**10. COMPOSITION INSULATORS** are made from various non-conducting mineral compounds and are usually forced into the moulds when in a heated plastic form. They are generally built in one piece. The manufacturers of such insulators claim very high mechanical and electrical values for their product.

**11. THE EFFECT OF MECHANICAL STRESS ON INSULATORS.** In an insulator, as in a steel spring, the maximum stresses to which it is subjected will materially affect its life and its reliability. Carrying the comparison still further, surges with steep

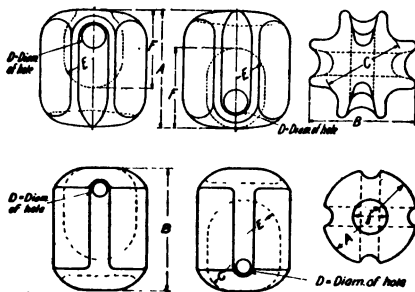

FIG. 129.—Porcelain strain insulators.

wave front may start an initial breakdown in the dielectric, the performance being similar to that of a spring worked to a point where the elastic limit is exceeded, beyond which point crystallization takes place very rapidly. If the severe conditions are maintained the life of the insulator or spring is necessarily very short.

Since the mechanical requirements of insulators are usually definite and as the mechanical loading affects the electrical factors of safety, such factors must be considered in insulator design. The suspension insulator being free from bending moments has many mechanical advantages over the pin or pedestal type insulator.

When the insulator is light and the span of the internal mechanical stresses of the insulator may usually be neglected with safety. Long spans and large conductors produce high working loads setting up stresses which, when combined with the internal stresses, may so lower the factor of safety that destruction of the dielectric will follow.

For the porcelain insulator it is necessary to consider the stresses set up by the working loads, those due to differences in the coefficients of expansion of the porcelain and the metal parts and the stresses set up by the cement or by the oxidation of the metal. For glass insulators, in addition to the above, the very uncertain internal stresses, due to uneven shrinkage in cooling, must also be considered.

The safe mechanical stresses that may be applied to insulators are generally determined experimentally, as they vary with the material and the design.

**12. THE EFFECT OF DIFFERENT TYPES OF PINS ON INSULATOR CHARACTERISTICS.** The pin has practically no effect on the mechanical characteristics of an insulator, as the insulator is usually much stronger than the pin. A load applied to the insulator sufficient to produce a bending moment on the pin will usually bend or break the pin before any damage occurs to the insulator. Metal pins or pins with metal through bolts, mounted on grounded arms or on steel structures, carry the ground potential into the pin hole and, therefore, increase the electrical stress on the insulator head. Metal pins on wood arms have practically no effect on insulator characteristics. All wood construction relieves the electrical stress on the insulator, as a part of the dielectric strain is taken up by the wood.

On transmission lines for the higher voltages there is more or less leakage of electricity over the insulator to the pin. This discharge in some cases produces a gradual charring or burning of the surface of the pin, that sooner or later destroys it. In others the wood does not appear to burn, but a peculiar destructive action not fully understood sets in and destroys the pin. The phenomenon resembles a rapid dry rot. The pin threads crumble away and the fibres disintegrate until the pin may be crumbled into dust by the hand. According to one theory the leakage over the pin produces a certain amount of nitric acid that gradually corrodes and destroys it.

In order to prolong the life of wood pins it is customary to boil them in some insulating compound, such as oil or paraffin. When this process is carefully conducted by boiling the pin in a vacuum so that the air that is inevitably contained in the wood may be exhausted and the cells filled with the boiling preservative compound the life of the pin is much prolonged and its insulating qualities much improved.

When glass insulators are used, insulator pins should be composed of wood, steel shanks with wood thimbles, or so arranged that a cushion is provided between the insulator and the pin. This is necessary because of the relatively low coefficient of expansion of glass, which, when all metal pins are used, causes mechanical failure.

**13. ELECTRICAL CHARACTERISTICS.** Insulators should be designed so that they will flashover before puncturing. On pin type insulators the ratio between puncture and flashover is about 1.35 to 1. The present tendency is to increase this ratio.

The ratio between puncture and flashover voltage for suspension type insulators is practically the same. This applies, however, to each unit in the string. The number of units required in a string may change this ratio depending upon the insulator design, the distance maintained between insulator units, and the distance between the insulator string and adjacent metallic object.

Various types of Pin, Suspension and Strain Insulators are illustrated in Figs. 111 to 132.

**14. AGEING OF INSULATORS.** Insulators that have satisfactorily passed factory and subsequent tests by the purchaser have

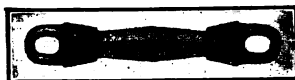

FIG. 130.—Wood strain insulator.



FIG. 131.—Composition strain insulator.

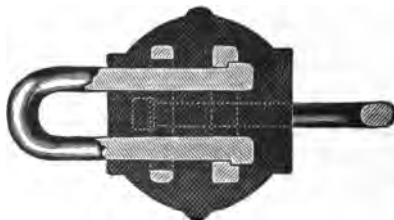

FIG. 132.—Composition strain insulator.

in some cases shown poor performance after having been in service for several years. There is considerable difference in opinion as to whether there is any change in the physical properties of an insulator which can be attributed to ageing.

Fatigue of materials is known to exist in cases where continuous mechanical stress is applied. It is therefore plausible to believe, until some proof to the contrary is furnished, that dielectric ageing due to electrical shock does exist. Insulator failures may also

be due to the gradual breakdown of the dielectric rather than to physical change due to continued electrical shock, or may be the result of very high frequency disturbances, which will puncture rather than flashover the insulator.

The so-called ageing is probably due to the development and gradual spreading of small cracks. These cracks may be started by internal strains, loads working too near their mechanical break-down point, cement expanding and over-voltage surges (cumulative effect).

**15. TESTING INSULATORS.** It is the practice of many companies to subject all insulators to tests in addition to the usual factory tests. Such tests will necessarily vary, depending upon the line under construction and the availability of testing equipment. The following tests are given as representing general practice. Any one or all of them may be applied, depending upon the desires of the individual purchaser.

**16. INSULATOR TESTS.** The tests on insulators may be divided into five (5) sections as follows:

#### TESTING

- |                        |   |
|------------------------|---|
| (a) Elimination Tests. | 1-Pin type (Art. 17.)<br>2-Sus. type (Art. 18.) |
| (b) Dry Arcing Tests.  | 1-Pin type (Art. 19.)<br>2-Sus. type (Art. 20.) |
| (c) Rain Arcing Tests. | 1-Pin type (Art. 21.)<br>2-Sus. type (Art. 22.) |
| (d) Mechanical Tests.  | 1-Pin type (Art. 23.)<br>2-Sus. type (Art. 24.) |
| (e) Puncture Tests.    | 1-Pin type (Art. 25.)<br>2-Sus. type (Art. 25.) |

**17. Elimination Tests on Pin Type Insulators.** Such tests usually consist in testing all the complete insulators by inverting them in a pan of water, of such a depth as to cover the center of the side wire groove. The inside of the insulators is then filled with water until the thread is covered. Voltage is applied between the water inside and outside of the insulator. The value of this voltage is generally regulated so that it is just below the arc-over value of the insulator and it is applied for about one minute. By such a test the faulty insulators are eliminated. The insulator, when tested in this manner, will arc-over at a lower voltage than when mounted in its proper position, as the total amount of leakage surface is reduced by an amount proportional to the ratio of the leakage surface covered by water, to the original leakage surface.

**18. Elimination Tests on Suspension Type Insulators.** Each unit is tested in the same manner as that used for testing Pin Insulators, thus eliminating any defective units before assembling. Completed insulator strings may also be so tested.

**19. Dry Arc-Over Test on Pin Type Insulators.\*** A proportional number of assembled insulators are mounted on metal pins under conditions resembling those to which the insulator will be subjected when in service, and voltage is applied between the pin and a rod attached to the insulator in a position similar to that which the line wire will occupy. The arc-over voltage obtained in such a test will be considerably higher than that obtained in the elimination tests.

**20. Dry Arc-Over Tests on Suspension Type Insulators.\*** A proportional number of units for given service conditions are assembled and suspended from a metal hook or clamp. A rod is then attached to the wire clamp of the lowest insulator in a position similar to that which the line wire will occupy. Voltage is applied between the cap of the top insulator and the rod until a flashover occurs. The arc-over voltage of several units in series will not be a multiple of that of one unit, but each additional unit will increase the flash-over voltage by approximately the amount the second unit adds to the arc-over voltage of one unit when two are placed in series.

**21. Rain Arc-Over Tests on Pin Type Insulators.** There are so many variables entering into results obtained in this test that it is not safe to compare various types of insulators unless all the conditions of the test are similar. Some of the conditions causing discrepancies are as follows:

- The quality of water.
- The quantity of water.
- The pressure of water.
- The distance of nozzles from unit under test.
- The fineness of the spray.
- The angle of contact with the unit under test.
- The barometric pressure.

Some of these conditions are difficult to regulate. The quality of water will vary with the locations at which the test is made. Careful experimenters have found that it is practically impossible to exactly duplicate results, even with laboratory methods and apparatus. This test, however, will give a general idea of what the insulators will do under adverse conditions and when made at any one testing station, furnishes fairly reliable comparative information. The usual method of making this test is to mount the insulators in the same manner as that used when making the dry arc-over test, throwing a fine spray of water on the insulator from an angle of about 45° to the horizontal. The precipitation is adjusted to equal approximately 1 inch in five minutes. A determination of the flashover voltage is obtained during precipitation which value obviously will be materially lower than the dry flashover voltage.

---

\* The arc-over voltage of insulators decreases with increasing altitudes or decreasing barometric pressure. For instance, if the arc-over voltage is "E" at sea level, it will be considerably less than "E" at a higher altitude, say 6000 feet. Allowance should, therefore, always be made for this phenomenon.

**22. Rain Arc-Over Test on Suspension Type Insulators.** Insulator strings are mounted in a manner similar to that used in measuring the dry arc-over value and a fine spray of water is thrown upon the assembled string at an angle of  $45^{\circ}$  from the horizontal, the precipitation also being regulated to equal approximately 1 inch in five minutes. The wet arc-over voltage is obtained during precipitation.

**23. Mechanical Test on Pin Type Insulators.** The usual test applied to pin type insulators consists of mounting the insulator on a rigid pin and applying a pressure at the side tie wire groove in a direction perpendicular to the vertical axis of the insulator. In general, it may be said that a high voltage insulator should stand a pull that will bend or break any metal pin on which it is likely to be used. For general use, a two thousand pound pull which is an average value to apply in such tests, should not cause any fracture.

**24. The Mechanical Tests on Suspension Type Insulators** consist in applying tension between the metal cap on the top of the unit and the connection link beneath the unit. The ultimate breaking load for suspension insulators varies from 4,000 to 30,000 pounds in accordance with the design of the insulator.

**25. Puncture Tests.** Tests on a certain percentage of each 1000 insulators, not exceeding one-quarter of one percent should be made to determine the ability of the insulator to resist puncture. This test is best made by submerging the insulator in oil.

Suspension insulators should be completely assembled with the standard fittings with which they are to be used in service.

With pin type insulators there should be attached to the head of the insulator, wires representing the tie and line wires, and a metal pin should be placed in a proper manner in the pin hole.

The test should then be applied to the fittings in each case. The puncture value obtained under these conditions should not be less than 135 percent of the dry flashover voltage.

In making the test, apply to the insulator a voltage 30 to 40 percent below the dry flashover value for 30 seconds, then raise the voltage by steps at a rate of about 1000 volts per second until puncture occurs.

**26. Method of Measuring Test Voltage.** The method of determining the value of the test voltage should be in accordance with that described in Art. 23a Sec. 6 Part I.

**27. INSULATOR PROTECTION.** Power arcs are frequently started by lightning discharges and result in burning and breaking of the transmission cables, whereupon the towers are subjected to unbalanced stresses which sometimes cause their failure. Lightning arresters, suitable for the protection of station apparatus, are available, but such arresters do not protect the lines themselves.

A number of special devices may be employed at points on the line where lightning is likely to be severe, in order to prevent the

## Sec. 5

## INSULATORS

burning of conductors and the shattering of insulators. The arcing horns and the double ring scheme are two such devices. The former consists of two horns, one connected to the insulator head and the line and the other to ground, the gap between them being adjusted so that a discharge will take place across it, rather than across the insulator. The double ring device consists of a ground ring supported by the crossarm so that it encircles the lower petticoat of the insulator with several inches clearance, and of a second ring connected to the line and resting near the edge of the top petticoat. A flash-over will usually occur between the rings without shattering the insulator.

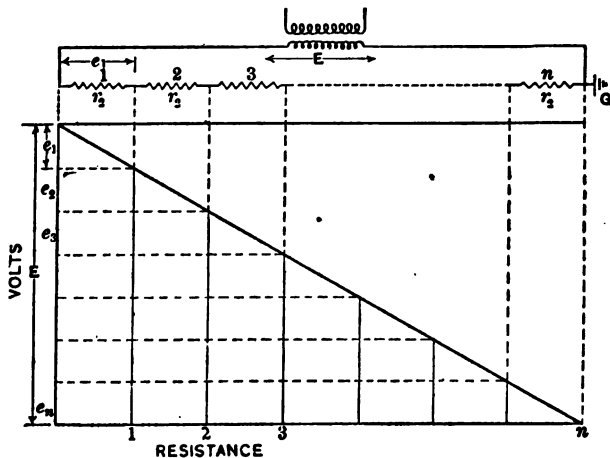

FIG. 133.

**28. THE VOLTAGE DISTRIBUTION ON THE SUSPENSION INSULATOR STRING**, where all units are alike varies depending upon the ratio of the leakage current to the capacity current.

If leakage predominates the voltage will be equally distributed between the units of the suspension string, but if the capacity effect predominates the voltage will be highest across the insulator nearest the line wire and gradually diminish; the unit nearest the ground having the least voltage stress.

### 29. Effect of Leakage.

$E$  = total voltage across string.

$r_2$  = leakage resistance of each unit.

$i_t$  = current flowing over insulator surface from line to ground.

$n$  = number of insulator units in a string.

# INSULATORS

## Sec. 5

If a number of equal resistances are connected in series in a string as in Fig. 133 and voltage  $E$  is applied across the string the total current is

$$i_t = \frac{E}{n r_1}$$

The voltages across all resistances are equal;

$$e_1 = e_2 \dots \dots \dots = e_n = i_t r_1$$

and

$$E = n e_1 = n e_2 = \dots \dots \dots = n e_n$$

This represents the voltage distribution when both the upper and lower insulator surfaces are wet and the leakage resistance rather than the capacity of the insulator string determines the voltage distribution.

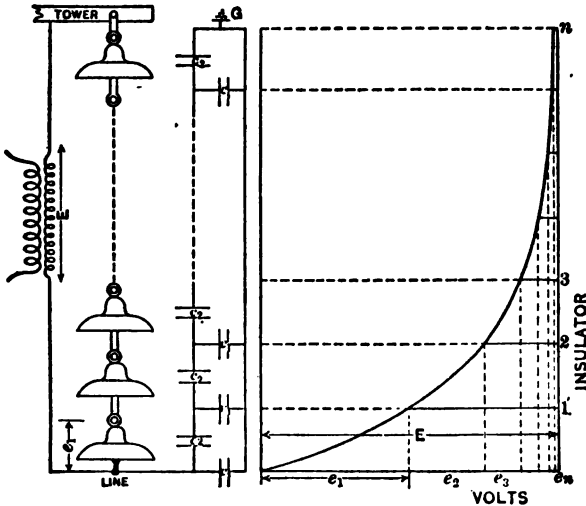

FIG. 134.

The voltage distribution due to the combination of the capacities of the insulators in the string, from line to ground and from each insulator to ground, is as follows:

Let Fig. 134 represent a string of suspension insulators grounded at one end, G, as at the tower. Each insulator may be represented as a condenser with a capacity  $c_2$ , and each connecting link and cap may be represented as a condenser with a capacity  $c_1$  to ground. Greater capacity current passes through insulator (1) than through



insulator (2), etc., hence, the voltage across the insulator (1) is greater than across insulator (2), etc., or, the voltage is not balanced along the string. The greater  $c_1$  is, when compared to  $c_2$  the greater the unbalancing. Also the greater the number of units in a string, the greater the unbalancing. The voltage across the different insulators of a given string can be readily calculated if the ratio  $\frac{c_2}{c_1}$  is known, and it is assumed there is no surface leakage or corona.

Leakage or corona will not appreciably affect the results at operating voltage.

Referring to Fig. 134 an expression for the total capacity of a string of  $n$  insulators may first be written.

### 30. Capacity of Insulator String.

Let  $c_2 = x c_1$

Then the total capacity for a string of  $n$  insulators is;

One insulator

$$k_1 = c_1 + c_2 = c_1 (1+x)$$

Two insulators

$$k_2 = c_1 + \frac{1}{\frac{1}{c_1 + c_2} + \frac{1}{c_2}} = c_2 \left( \frac{1}{x} + \frac{k_1}{c_2 + k_1} \right)$$

Three insulators

$$k_3 = c_1 + \frac{1}{\frac{1}{k_2} + \frac{1}{c_2}} = c_2 \left( \frac{1}{x} + \frac{k_2}{c_2 + k_2} \right)$$

For a string of  $n$  insulators.

$$k_n = c_1 + c_2 - \frac{c_2^2}{c_2 + k_{n-1}} = c_2 \left( \frac{1}{x} + \frac{k_{n-1}}{c_2 + k_{n-1}} \right)$$

31. Effect of Capacity. Let  $E$  be the voltage across the string to ground (Fig. 135).

$i$  = total capacity current.

$x = \frac{c_2}{c_1}$   $c_2$  = mutual capacity or the capacity of each insulator.  
 $c_1$  = capacity to ground.

$k_n$  = total capacity of the string.

$$k = \frac{k_n}{c_1}$$

Then

$$i = 2 \pi f k_n E$$

$$i_1' = 2 \pi f c_1 E$$

Then the voltage across the first or line insulator is

$$e_1 = \frac{i - i_1'}{2 \pi f c_2} = \frac{2 \pi f E (k_n - c_1)}{2 \pi f c_2}$$

$$e_1 = E \frac{(k_n - c_1)}{c_2} = \frac{E}{x} (k - 1)$$

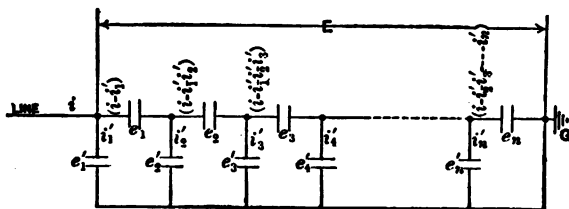

FIG. 135.

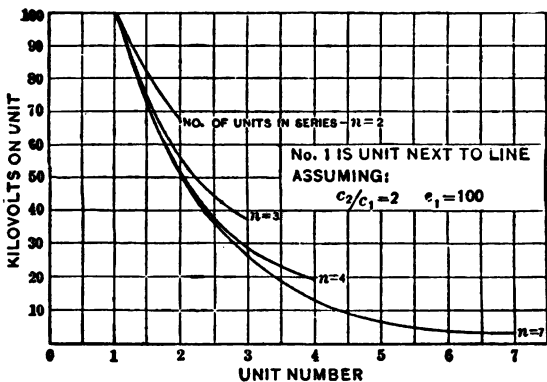

FIG. 136.—Calculated voltage across different insulators in a string of "n" units.

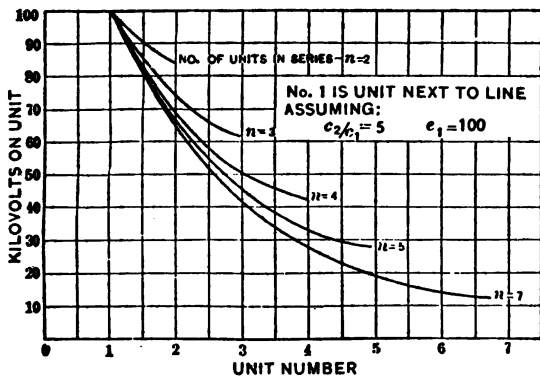

FIG. 137.—Calculated voltage across different insulators in a string of "n" units.

Sec. 5

INSULATORS

The voltage  $e_2$  across the second insulator is found thus:

$$e'_1 = E - e_1 = E \left( \frac{x-k+1}{x} \right)$$

$$i'_2 = 2 \pi f e'_1 c_1 = 2 \pi f c_1 \left( \frac{x-k+1}{x} \right) E$$

Therefore

$$e_2 = \frac{i - i'_1 - i'_2}{2 \pi f c_2} = E \frac{k(x+1) - (2x+1)}{x^2} = \frac{E}{x} \left( k - 2 + \frac{k-1}{x} \right) = e_1 - \frac{e'_1}{x}$$

For the third insulator

$$e_3 = E \frac{x(x+1)(k-1) + (2x+1)(k-1) - x(x+1)}{x^3} \\ = \frac{E}{x} \left( k - 3 + \frac{3k-4}{x} + \frac{k-1}{x^2} \right) = e_2 - \frac{e'_2}{x}$$

For the nth insulator

$$e_n = \frac{E}{x} \left( (k-n) + \frac{\dots}{x} + \frac{\dots}{x^2} + \dots + \frac{k-1}{x^{n-1}} \right) = e_{n-1} - \frac{e'_{n-1}}{x}$$

From the above the following equations may be written for solving numerical problems.

Total capacity of a string of n insulators.

$$(1) k_n = c_1 + c_2 - \frac{c_2^2}{2c_2 + c_1 - c_2^2} \\ \frac{2c_2 + c_1 - c_2^2}{2c_2 + c_1}$$

Write fraction to n-1 of the 2 c<sub>2</sub> + c<sub>1</sub> terms.

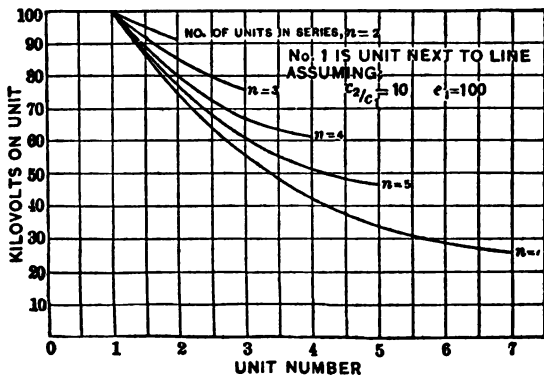

FIG. 138.—Calculated voltage across different insulators in a string of "n" units.

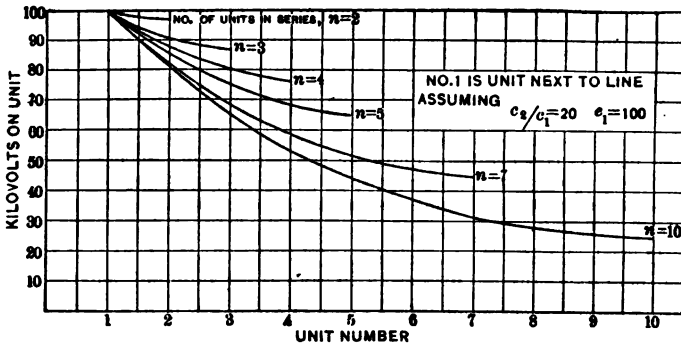

FIG. 139.—Calculated voltage across different insulators in a string of "n" units.

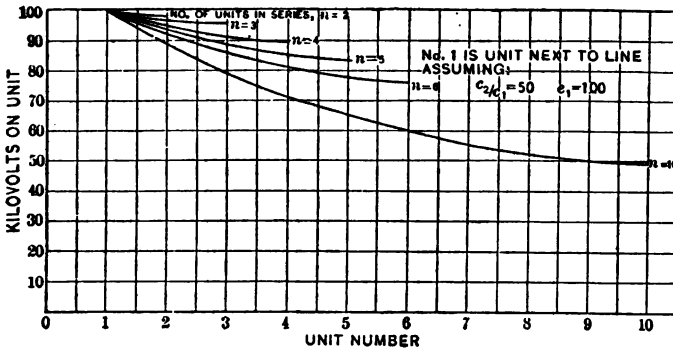

FIG. 140.—Calculated voltage across different insulators in a string of "n" units.

- (2) Volts across first or line insulator of string of n is

$$e_1 = \frac{E}{x}(k-1)$$

$$k = \frac{k_n}{c_1}$$

- (3) The voltage across the mth insulator of a string is

$$e_m = e_{m-1} + \frac{e_{m-1} + e_{m-2} + \dots + e_1 - E}{x}$$

- (4)  $E = \frac{e_1 x}{k-1}$

Sec. 5

INSULATORS

When the arc-over voltage of a single unit alone  $e_a$  is taken for  $e_1$ .

$$(4a) E_a = \frac{e_a x}{k-1} = \text{arc-over voltage of string.}$$

$$(5) \text{String efficiency} = \frac{E_a}{n e_a} = \frac{x}{n(k-1)}$$

String efficiency is materially effected by the type of, and the spacing between insulator units, as the performance of some types of closely spaced insulators results in the breaking down of the air paths between the terminals, before a flashing potential is obtained across any unit.

32. Calculated Characteristics. The method of calculating the characteristics of insulators in series, for different lengths of string and different values of  $\frac{c_2}{c_1}$ , using formulae 1, 2, 3, 4 and 5 follows:

Ratio $c_2/c_1$	1	2	5	10	15	20	50	100	500	1000
No. of insulators in series	Values of K									
1	2.000	3.000	5.000	11.000	16.000	21.000	51.000	101.00	501.00	1001.00
2	1.667	2.309	3.723	6.238	8.742	11.244	26.247	51.21	251.25	501.25
3	1.625	2.048	3.135	4.842	6.387	8.197	18.998	34.89	173.22	334.89
4	1.619	2.012	3.227	4.263	5.546	6.814	14.250	26.87	126.87	251.87
5	1.618	2.003	3.246	3.988	5.049	6.063	12.172	22.20	102.20	202.20
6	"	2.001	3.214	3.851	4.777	5.676	10.777	19.19	85.23	169.23
7	"	2.000	3.201	3.781	4.623	5.421	9.863	17.15	74.26	145.22
8	"	"	2.795	3.743	4.574	5.265	9.228	15.69	65.68	128.18
9	"	"	2.793	3.724	4.505	5.178	8.797	14.62	59.68	114.62
10	"	"	2.792	3.712	4.465	5.100	8.481	13.85	53.25	103.25
11	"	"	"	3.708	4.447	5.069	8.251	13.22	49.68	95.69
12	"	"	"	3.705	4.415	5.044	8.063	12.84	46.22	91.25
13	"	"	"	3.702	4.411	5.036	7.958	12.52	43.28	81.75
14	"	"	"	3.702	4.409	5.024	7.845	12.32	40.93	76.52
15	"	"	"	3.702	4.407	5.015	7.796	12.17	38.21	72.21

To find the total capacity of the string,  $k_n$ , take the  $k$  above for the required ratio  $\frac{c_2}{c_1}$ , and the given number of insulators in series and multiply by  $c_1$ .

$$K_n = k c_1$$

As an example of use of formulae, assume

$$\frac{c_2}{c_1} = \frac{5}{1} = x$$

$$n=3 \quad E=100 \quad k = \frac{k_n}{c_1}$$

$$\text{From (1)} \quad k_n = c_1 + c_2 - \frac{c_2^2}{2c_1 + c_2 - c_2^2}$$

## INSULATORS

Sec. 5

$$k_n = 1 + 5 - \frac{25}{10 + 1 - 25} = 1 + 5 - \frac{25}{11 - 2.27} = 3.135$$

$$\frac{25}{10 + 1}$$

From (2)  $e_1 = \frac{E}{x}(k-1)$

$$= \frac{100}{5}(3.135 - 1) = 42.7$$

From (3)  $e_2 = e_{2-1} + \frac{e_{2-1} - E}{x} = e_1 + \frac{e_1 - E}{x}$

$$= 42.7 + \frac{42.7 - 100}{5} = 31.3$$

$$e_3 = e_{3-1} + \frac{e_{3-1} + e_{2-1} - E}{x} = e_2 + \frac{e_2 + e_1 - E}{x}$$

$$e_3 = 31.3 + \frac{31.3 + 42.7 - 100}{5} = 26$$

$$E = e_1 + e_2 + e_3 = 100$$

If 42.7 is considered as the arc-over voltage of a unit then the string efficiency is—

$$\frac{100}{3 \times 42.7} = 0.78 = 78\%$$

Figs. 136 to 140 and Table 55 are given as an aid in calculating the voltage distribution across an insulator string. The values in each figure are calculated for various numbers of insulators in a string, assuming ratios of  $\frac{c_2}{c_1}$  and the voltage across the insulator next to the line equal to 100 kv.

If this voltage is less, the voltage across the remaining insulators of the string will also be proportionately less.

Values of  $k$  are given in Table 55 for various values of  $\frac{c_2}{c_1}$  and for various numbers of insulators in series.

To demonstrate the use of the table and curves the following problem is given:

**Problem.** Find the distribution of voltage across each unit of a suspension insulator string consisting of four units where the voltage from the line conductor to ground is 100 kv., assuming a ratio of mutual capacity to capacity to ground of five.

$$x = \frac{c_2}{c_1} = 5 \quad n = 4 \quad E = 100 \text{ kv.}$$

From Table 55 for  $\frac{c_2}{c_1} = 5$  and  $n = 4$ .

Find  $k = 2.927$ .

Sec. 5

INSULATORS

Then

$$e_1 = \frac{100}{5} (2.927 - 1) = 38.54 \text{ kv.}$$

$$\text{String efficiency} = \frac{100}{4 \times 38.54} = 0.649 = 64.9\%$$

From curve Fig. 137 assuming  $e_1 = 100$  kv.

The relative values of  $e_2$ ,  $e_3$  and  $e_4$  may be found, and the actual value then obtained by proportion.

	From Fig. 137	Actual
$e_1$	100.00 kv.	= 38.54
$e_2$	68.5 "	= 26.35
$e_3$	51.0 "	= 19.60
$e_4$	42.5 "	= 16.35

100.84 error .84%

Assuming that 50 kv. is the flashover value of one unit, the flash-over value of the string is

$$E_a = 50 \times 4 \times 0.649 = 129.8 \text{ kv.}$$

The drawn curves in Fig. 141 are the theoretical ones for  $e_a = 74$  kv. for dry insulators and  $\frac{c_2}{c_1} = 10$ ,  $\frac{c_2}{c_1} = 15$ , and  $\frac{c_2}{c_1} = 20$ .

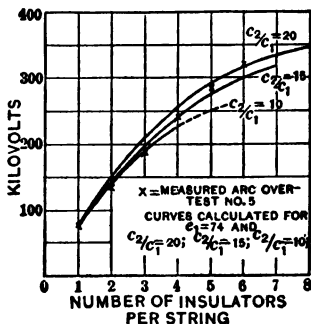

Fig. 141.—Comparison of calculated and test curves.

The crosses (Fig. 141) are the measured values. This illustrates the effect of automatic grading due to corona and leakage. For short strings the points follow the curve for  $\frac{c_2}{c_1} = 10$ , which if continued would give a very low flashover efficiency.

Automatic grading causes the points to gradually shift to the curve for  $\frac{c_2}{c_1} = 20$ . The actual value of  $\frac{c_2}{c_1}$  under operating voltage

is probably between 5 and 10. Thus, while arc-over tests for long strings may indicate a fair efficiency, the insulator string is in reality operating at a very bad unbalance of voltage.

The curves in Fig. 142 illustrate how moisture affects the voltage distribution of the string. The curve of dry arc-over voltage follows the law of capacities. The curves of rain arc-over voltages follow the law of resistances.

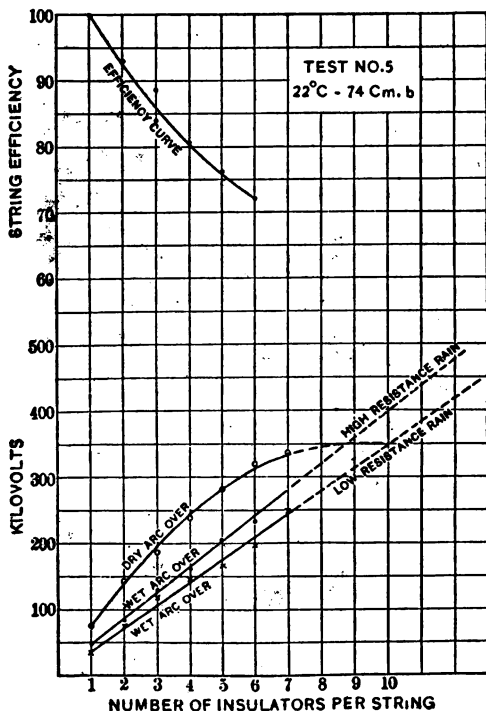

FIG. 142.—Test characteristic curves of suspension insulators.

**33. GRADING THE CAPACITY OF INSULATORS.** It has been suggested and rather strongly urged abroad that insulator capacities be graded, i.e. an insulator having a large capacity placed next to the line, one having a small capacity, placed next to the support and the capacity of the intermediate insulators graded between the capacity of the two extreme insulators.



Since the current varies on each section, the capacity must vary accordingly, in order that a uniform distribution of stress may result. To obtain uniform stress distribution in this manner would require each unit in the series to be different in type from every other unit, and the advantage of the interchangeability of parts would be lost. Although considered impracticable for the suspension insulator units, such methods of distributed capacity have been found very valuable in distributing the stress in the pin type insulator.



FIG. 143.—Illustrating the effect of insulator capacity on voltage distribution.

That the stress distribution can be controlled by a change in the capacity of each insulator and from each insulator to ground is illustrated by the following:

Fig. 143 illustrates a suspension insulator composed of two sections the upper having a small electrostatic capacity in comparison to that of the lower insulator. The flash-over value of the small insulator is 57 kv. but when a potential of 62 kv. was applied to the

series the small insulator was stressed to its flash-over potential. The photograph was taken with 62 kv. on the series and shows the charging current of the large insulator forming an arc over the smaller. To flash over the entire series, requires 150 kv.

Fig. 144 illustrates an insulator of relatively small electrostatic capacity between two sections of larger capacity. When tested alone, flashing potential of the small unit was 57 kv. The photo-



FIG. 144.—Illustrating the effect of insulator capacity on voltage distribution.

graph was taken with 97 kv. applied to the series, which was sufficient to overstress the small insulator, while 300 kv. were required to flashover the series. When it is considered that the over-stressed member shown in Fig. 144 adds but little to the flashover of the remaining insulators, it is seen why insulator designs may be very inefficient.

**BIBLIOGRAPHY**

- N. E. L. A., June, 1913, A. O. Austin.  
A. I. E. E., June, 1911, A. O. Austin.  
A. I. E. E., June, 1913, Peek, Thomas & Sanford.  
A. I. E. E., May, 1912, F. W. Peek, Jr.  
Publications of Various Manufacturers.

# **SECTION 6**

---

## **PART I**

**TRANSFORMERS AND INDUCTION REGULATORS**

---

## **PART II**

**LIGHTNING PHENOMENA IN CONNECTION  
WITH ELECTRIC CIRCUITS, PROTECTIVE  
APPARATUS, GROUNDING**

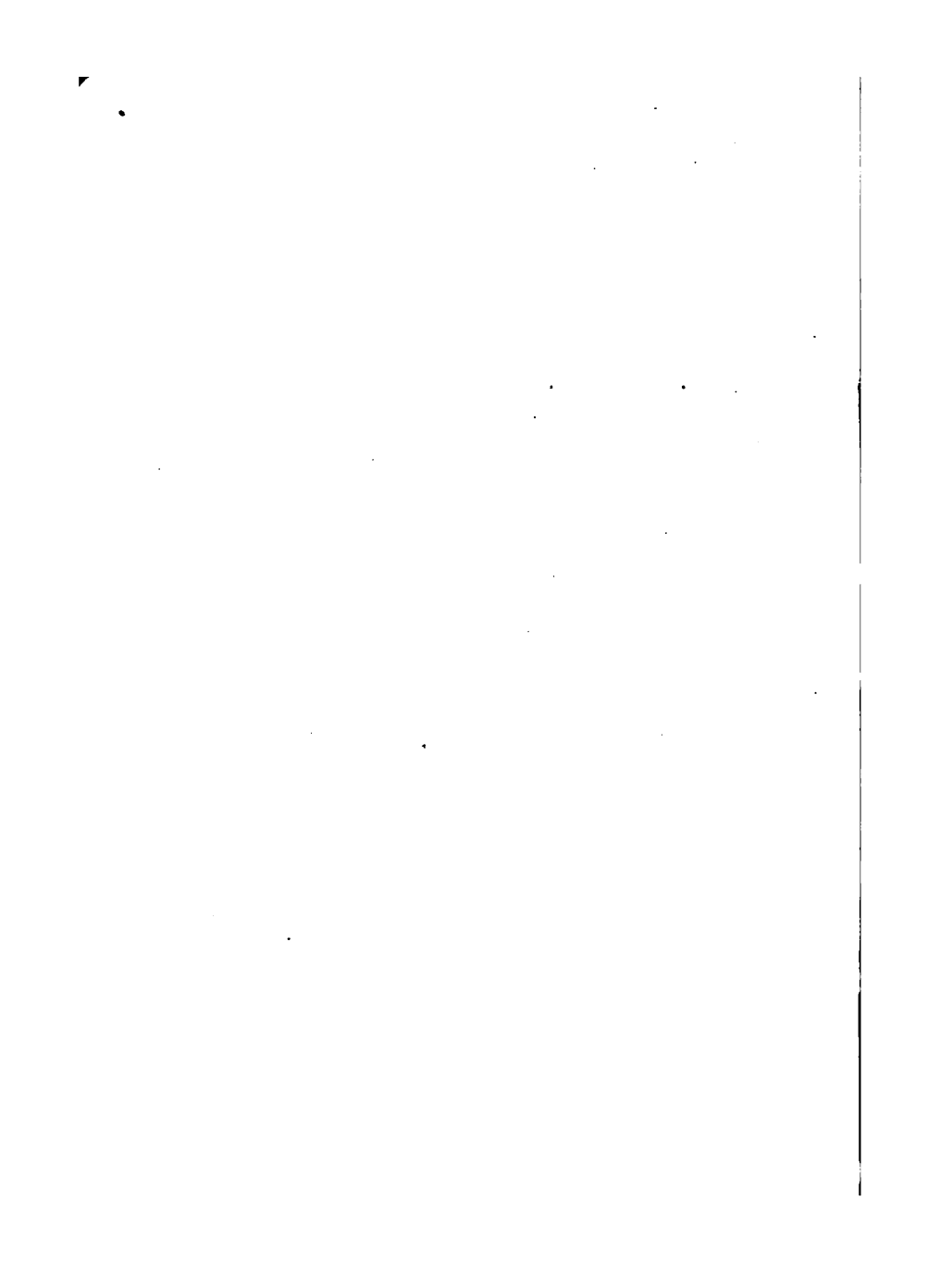

## SECTION 6

### PART I—TRANSFORMERS AND INDUCTION REGULATORS

#### TABLE OF CONTENTS

	ARTICLE
Definitions .....	1
<b>Transformer Construction.</b>	
General .....	2
Cores .....	3
Coils .....	4
Cases .....	5
<b>Transformer Equations.</b>	
General .....	6
Hysteretic Losses .....	7
Eddy Current Losses .....	8
Copper Losses .....	9
Exciting Current .....	10
Induced Voltage .....	11
Ratio .....	12
Equivalent Resistance and Reactance .....	13
<b>Features of Design</b> .....	14
Insulation .....	15
Temperature .....	16
Efficiency .....	17
Regulation .....	18
Magnetic Fatigue or the Ageing of Steel .....	19
Power-factor .....	20
<b>Transformer Characteristics</b> .....	21
<b>Transformer Testing</b> .....	22
Insulation .....	23
Heating Tests .....	24
Core Loss and Exciting Current .....	25
Resistance Measurements .....	26
Copper Loss .....	27
Reactance Drop .....	28
Regulation .....	29

**Sec. 6****TRANSFORMERS**

	<b>ARTICLE</b>
Ratio.....	30
Polarity.....	31
<b>Transformer Specifications</b>	
Transformers.....	32
Transformer Oil.....	33
<b>The Operation of Large vs. Small Transformer.....</b>	<b>34</b>
<b>Polyphase Transformers.....</b>	<b>35</b>
<b>Parallel Connecting of Transformers.....</b>	<b>36</b>
<b>Scott Transformation Vector Analysis.....</b>	<b>37</b>
<b>Special Series Incandescent Lighting Transformers.....</b>	<b>38</b>
<b>Induction Regulators</b>	
General description.....	39
Pole Type Regulators.....	40
Induction Regulator Tests.....	41

**1. DEFINITIONS.** Transformers and alternating current voltage regulators are **Stationary Induction Apparatus** which are defined as apparatus changing electrical energy to electrical energy through the medium of magnetic energy. It comprises several forms distinguished as follows:

(a) **TRANSFORMERS**, in which the primary and secondary windings are insulated one from another.

A **primary winding** is that winding of a transformer, or of an induction motor, which receives energy from an external source.

A **secondary winding** is that winding of a transformer, or of an induction motor, which receives energy from the primary by induction.

**NOTE:** The terms "**High-voltage winding**" and "**Low-voltage winding**" are suitable for distinguishing between the windings of a transformer, where the relations of the apparatus to the source of power are not involved.

(b) **AUTO-TRANSFORMERS**, also called **COMPENSATORS**, in which a part of the primary winding is used as a secondary winding, or vice versa.

(c) **POTENTIAL REGULATORS**, in which one coil is in shunt and one in series with the circuit, so arranged that the ratio of the transformation between them is variable at will. They are of the following three classes:

(1) **Contact Voltage Regulators**, also called **Compensator Regulators**, in which a varying number of turns in one or both of the coils is adjustable.

(2) **Induction Potential Regulators** in which the relative positions of the primary and secondary coils are adjustable.

(3) **Magneto Potential Regulators** in which the direction of the magnetic flux with respect to the coils is adjustable.

(d) **REACTORS** or **REACTANCE COILS**, also called **CHOKE COILS**; a form of stationary induction apparatus used to supply reactance or to produce phase displacement.

(e) **CONSTANT CURRENT TRANSFORMERS** or those in which the primary voltage is maintained constant and the secondary voltage varies with the load, the secondary current remaining approximately constant. These characteristics are obtained by automatically increasing or decreasing the separation between the primary and the secondary coils, thus decreasing or increasing the voltage generated in the secondary, due to the increased or decreased magnetic leakage between the coils. The voltage thus varies with the impedance of the load, while the current remains constant within the range of the regulating characteristics of the transformer.

## **TRANSFORMER CONSTRUCTION**

**2. General.** Transformers consist of a laminated steel core upon which are wound insulated coils of copper wire. This assembly



of copper and steel is placed in a metallic tank containing oil, which reinforces the insulation of the coils by the insulating strength of the oil. The tank also protects the transformer windings from injury. The connections from the coils are brought out through insulated bushings varying in type with the voltage requirements. (Figs. 145 to 148.)

3. **Cores.** Transformer cores consist of a number of sheets of steel (called laminations) insulated from one another by a thin film of oxide, varnish or similar substance. These sheets vary in thickness from 0.014 inches to 0.025 inches, depending upon the capacity and frequency of the transformer under construction. They are



FIG. 145.—Condenser type transformer bushing, 60,000 volts.



FIG. 146.—Oil insulated transformer bushing, 70,000 volts.

so constructed in order to minimize core loss due to eddy currents. (Art. 8).

Transformers are of two fundamental designs, namely:—the shell and the core type.

In the shell type the iron circuit surrounds the transformer coils.

In the core type the copper windings surround the iron core.

All other forms of transformers may be considered as modifications of these two simple forms. A clear idea of the relation existing between these fundamental types may be secured from Fig. 149. It is evident from this figure that an interchange of the

iron and copper elements will transform the shell type into the core type and vice versa.

Distributed shell and core types of construction are developed from the simple forms as shown in Fig. 149. These types are developed from the simple forms by the addition of two small iron circuits to the shell type or two small copper elements to the core type. The distributed shell type is sometimes built with the four parts of the magnetic circuit interlocking, and is often called the "cruciform type."

The distributed shell type for small low voltage transformers can be constructed more cheaply for a given performance than the simple shell or core type on account of its short mean turn of

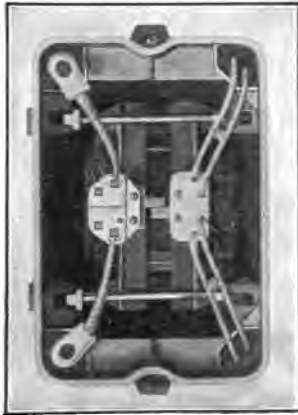

FIG. 147.—Method of insulating leads from case, 6600/110-220 volt transformer.



FIG. 148.—Method of insulating leads from case, 6600/110-220-440 volt transformer.

iron, and in other respects has equally good operating characteristics. For higher voltages and fairly small capacities the single core type is frequently used.

Silicon steel is the material used at present in transformer core construction and is superior to carbon steel, which was formerly used, as its use lowers the initial core loss of the transformer, which core loss remains practically constant throughout the life of the transformer, while transformers constructed with carbon steel cores have higher initial core loss, which loss increases with the age of the transformer due to the ageing of the steel.

4. Coils are universally built of insulated wire which may be round, square or rectangular in cross section. The latter type is usually

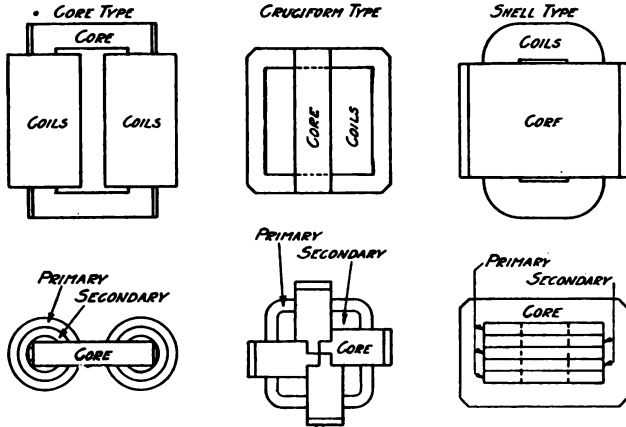

FIG. 149.—Types of transformer cores.



FIG. 150.—Secondary winding assembled on cruciform type transformer core.



FIG. 151.—Cruciform type transformer completely assembled (ready for placing in case.)

called ribbon wire. In small transformers of the cruciform type (Fig. 150) the conductor may be wound directly on the center leg of the core, or the coil form wound and then assembled on the iron.

There are two general types of transformer windings, those wound with the high and low tension elements arranged **concentrically**, and with these elements arranged side by side. The latter type of winding is usually referred to as the **pancake** or **interleaved** winding. The concentric winding is usually used on small transformers and the latter on large sizes. Each of these types of winding can be used with either the shell type of construction or with the core type.

The major insulation in a **concentric** winding consists of several large pieces of mechanically strong insulating material. In the **pancake** or **interleaved** windings there is relatively a larger number of small pieces of insulating material required, which, when thin or fragile material is used, necessitates careful workmanship in order to prevent defects in the finished product.



FIG. 152.—Core type coils assembled.

Small transformers with concentric type windings are more easily insulated than the pancake type of similar sizes; while large capacity pancake type windings have better mechanical properties than the concentric type.

Form wound coils are generally used on core type transformers although under some conditions it is possible to wind the copper directly on the core. In the larger capacity and higher voltage transformers of both the core and the shell type, form wound coils are universally used.

Core type transformers have also been constructed of a number of **flat formed coils** (Fig. 153) which construction facilitates assembling and insulation, as well as lending itself naturally to a more rugged construction in resisting strains due to abnormal operating conditions. It also permits the replacing of burnt-out coils at greatly reduced costs.

Transformer coils should be designed so that the **voltage between layers** will be as low as possible. Also the insulation should be such

that high factors of safety will be assured, as electrical disturbances may subject it to momentary voltages many times higher than the normal voltage of operation. The usual range of voltage between turns is from 0.5 to 10 volts and between layers from 100 to 300 volts. The puncture voltage value between turns should be from 800 to 1500 volts and between layers from 1500 to 3000 volts. These values vary with design and type of transformer.

In order to prevent an abnormal temperature rise in the transformer when in operation, oil ducts (Fig. 152) are generally located between the transformer coils and the core, and between the various



FIG. 153.—Interior view of core type transformer wound with flat formed coils.

sections of the transformer windings. These ducts permit the circulation of the transformer oil, which circulation prevents abnormal heating. In transformers of the smaller type oil ducts are seldom required, as the volume of oil surrounding the coil is usually sufficient to carry off the heat, thus preventing an abnormal temperature rise.

5. Cases are made of either cast iron or sheet steel. They must be oil tight. The leading-in bushings should have sufficient insulating strength to withstand the maximum voltage to which the transformer may be subjected and also should be water tight. The covers are usually made of cast iron and should be readily removable.

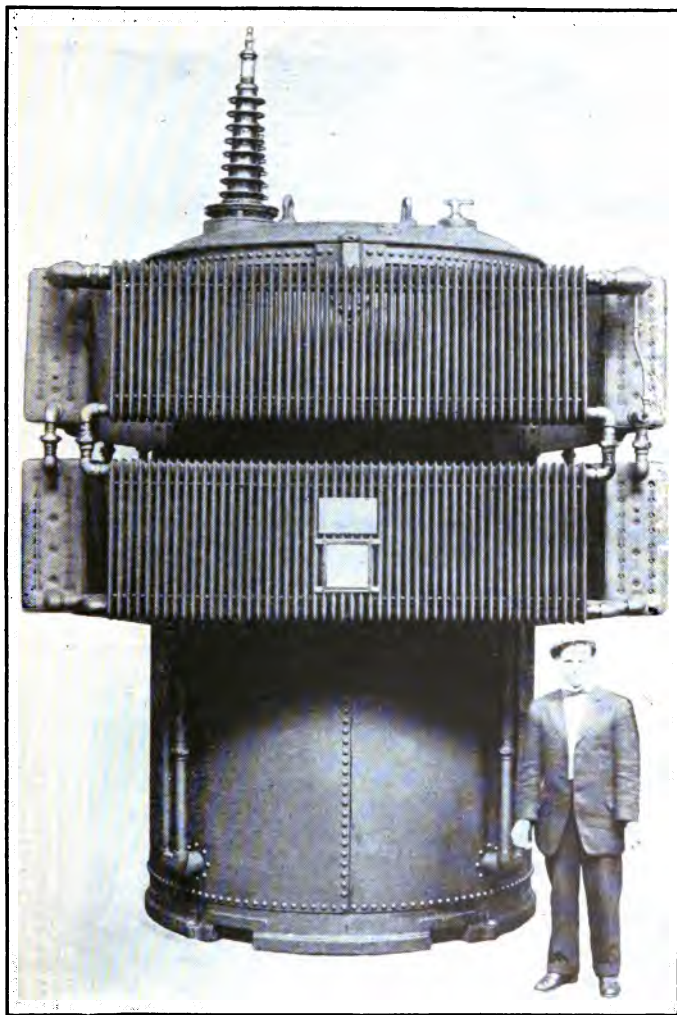
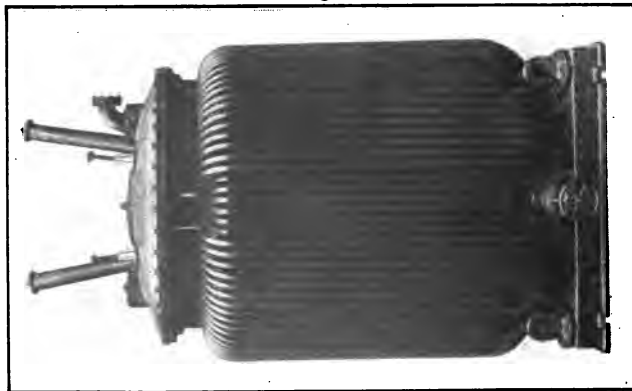

FIG. 154.—Self cooling out-door type transformer, single-phase, 3,000 kv-a  
66,000/2,200 volts, 25 cycles.



**Fig. 155.**—Self cooling out-door type transformer, single-phase, 2,000 kv-a, 101,200/13,200 volts, 60 cycles.



**Fig. 156.**—Water cooled out-door type transformer, single-phase, 2,000 kv-a, 150,000 volt primary, 60 cycles.

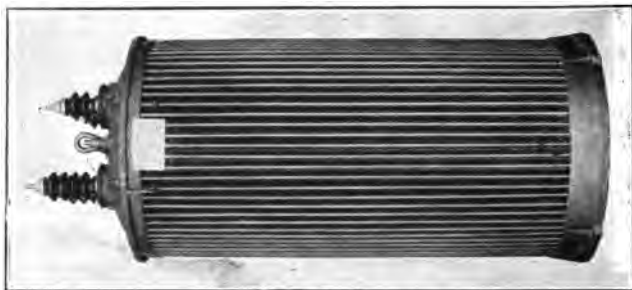

**Fig. 157.**—Self cooling out-door type transformer, single-phase, 500 kv-a, 33,000/5,600 volts, 60 cycles.

Experience has demonstrated that the normal exposed surface of the containing case of an oil immersed transformer does not provide sufficient radiating surface for transformers larger in capacity than 25 kw.; hence, for larger sizes the transformer cases are built with corrugated surfaces which increase the radiation sufficiently to prevent an abnormal temperature rise. These types of transformer cases are shown in Figs. 154 to 161.



FIG. 158.—Self cooling out-door type transformer, single-phase, 33,000 volt primary, 60 cycles.

### TRANSFORMER EQUATIONS

**6. General.** An ideal transformer should convert a given amount of electrical energy at a given voltage and frequency to the same amount of electrical energy at some other desired voltage and the same frequency; should completely isolate the two voltages, and should maintain a constant electromotive force at any load, provided the impressed electromotive force is constant. (An excep-



Sec. 6

TRANSFORMERS

tion to this is the series lighting or tub transformer which maintains a constant current at all loads.)

Commercial transformers are probably the most perfect energy converters in existence. The difference between the energy received and the energy delivered is consumed in the resistance losses of the



Fig. 159.—Self cooling out-door type transformer, three-phase, 100 kv-a, 2,200/220 volts, 60 cycles.



Fig. 160.—Self cooling out-door type transformer, three-phase, 20 kv-a, 2,200/220 volts, 60 cycles.

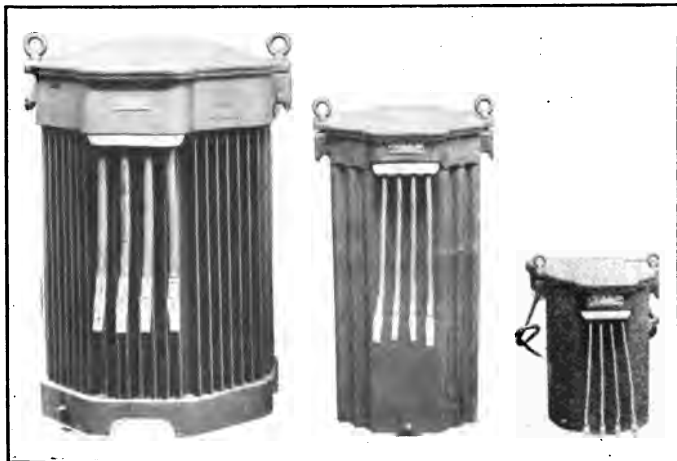

Fig. 161.—Self cooling out-door type transformers, single phase, 5-25 and 100 kv-a, 2,200/220 volts, 60 cycles. (Illustrates change in tank construction with increased capacity.)

copper windings and the magnetic losses of the steel core. The magnetic losses are those due to hysteric and eddy current phenomena.

**7. Hysteric Losses.** Hysteresis is that quality of a magnetic substance by virtue of which energy is dissipated on the reversal of its magnetization. For a given quality of steel this loss varies as the 1.6 power of the flux density. The following equations for hysteric loss have been determined by Dr. Steinmetz

Let

$W_1$  = the power in watts absorbed by hysteresis in the steel core.

$V$  = the volume of the core in cubic centimeters.

$f$  = the frequency in cycles per second

$\beta_{\max}$  = the flux density in lines per square centimeter

$k_h$  = the co-efficient of hysteresis depending upon the quality of steel.

Then

$$W_1 = \frac{k_h f V \beta_{\max}^{1.6}}{10^7}$$

Values of  $k_h$  vary from 0.0006 to 0.003, depending on the quality of the magnetic material and such values are experimentally obtained.

**8. Eddy Current Losses.** Eddy current losses are those due to the induced current in the steel laminations. This current is produced by the change in magnetic flux, which induces a voltage in the laminations. This voltage divided by the impedance of the effective circuit in each lamination determines the flow of current, the square of which times the resistance will give the loss in watts.

Let

$W_2$  = the power in watts absorbed by eddy currents in the steel core.

$V$  = the volume of the core in cubic centimeters.

$t$  = the thickness of steel sheets in centimeters.

$f$  = the frequency in cycles per second.

$\beta_{\max}$  = the flux density in lines per square centimeter.

$k_e$  = the coefficient of eddy current loss.

Then

$$W_2 = \frac{k_e f^2 t^2 V \beta_{\max}^2}{10^{11}}$$

The constant  $k_e$  varies with the specific conductivity of the core material and its value is experimentally determined. A fair value being approximately 0.65 for silicon steel.

The above two losses produce heat in the steel core and are practically constant at all loads. The total amount of energy absorbed is equal to the sum of the two losses and can be determined by the following equation.

$$W_e = W_1 + W_2$$

The energy component of the no-load transformer current is found by dividing the total transformer loss in watts at no-load by the transformer voltage.

$$I_c = \frac{W_e}{E}$$

**9. Copper Losses.** Copper loss in a transformer is the sum of the  $I^2r$  losses in both the primary and secondary windings.

Let

- $I_1$  = the load current in the primary winding in amperes.
- $r_1$  = the resistance of the primary winding in ohms.
- $I_2$  = the load current in the secondary winding in amperes.
- $r_2$  = the resistance in the secondary winding in ohms.
- $W_c$  = the total copper loss at full load in watts.

Then

$$W_c = r_1 I_1^2 + r_2 I_2^2$$

The total power loss at full load is the sum of the no-load and the full load losses, therefore

$$W_t = W_e + W_c$$

in which  $W_e$  is a constant quantity and  $W_c$  varies with the square of the load on the transformer.

**NOTE:** The effect of the loss produced by the no-load current of the transformer flowing through the primary resistance has been neglected as the error introduced thereby is small. However, if it is desired to consider it, the primary current  $I_1$  may be corrected for this effect by adding the no-load current to it vectorially. There is a small loss in the windings aside from the  $I^2r$  loss, due to the eddy currents, which are caused by the leakage magnetic flux.

**10. Exciting Current.** When the impressed voltage is a pure sine wave, the wattless component of the no-load current is never a sine wave. This deviation from a sine wave is caused by the variation in the flux density curve of the transformer steel and also by the fact that the increasing and decreasing saturation curves do not coincide. In ordinary calculations this complexity in the wave form of the magnetizing current of a transformer is generally neglected and very approximate calculations are based on a pure sine wave. With this assumption, the fundamental equation of magnetic relations is quite simple.

Let

$\phi_{\max}$  = the total maximum magnetic flux.

$N$  = the total number of turns on the transformer primary winding.

$I_m$  = the effective value of the magnetizing current in amperes.

$A$  = the area of the core in square centimeters.

$l$  = the length of the magnetic circuit in centimeters.

$\mu$  = the permeability of the iron.

Then

$$\phi_{\max.} = \frac{4 \pi N I_m \sqrt{2} A \mu}{10 \times 1} = \frac{1.26 N I_m \sqrt{2} A \mu}{1}$$

$$\text{and } \beta_{\max.} = \frac{4 \pi \sqrt{2} I_m N \mu}{10 \times 1}$$

Therefore

$$I_m = \frac{10 \beta_{\max} l}{4 \pi \sqrt{2} N \mu} = \frac{10 \phi_{\max} l}{4 \pi \sqrt{2} A N \mu}$$

The exciting current of the transformer is found by combining the quadrature vector sum of the power and wattless components.

Thus

$$I_e = \sqrt{I_c^2 + I_m^2}$$

The no-load power factor of the transformer is found by dividing the energy component of the current by the total exciting current.

Thus

$$\text{Cos. } \theta' = \frac{I_c}{I_e}$$

**11. Induced Voltage.** The calculation of the ratio between the impressed electromotive force and the counter electromotive force of the transformer winding is dependent upon the reactance and resistance drops in the transformer primary winding. This difference is usually a few percent and the method of determining it is given in Section 7, Article 49. The relations between the counter electromotive force of the transformer coil and the various factors, such as flux density, number of turns, frequencies, etc., are determined by the following formulæ. These equations are based on the assumption that the electromotive force is a true sine wave and are the most important formulæ used in the design of transformers.

Let

E = the effective induced electromotive force in volts.

$\phi_{\max.}$  = the total magnetic flux.

$\beta_{\max.}$  = the lines of magnetic flux per square inch.

A = the cross section of the magnetic circuit in square inches.

N = the total number of turns on the transformer primary winding.

f = the frequency in cycles per second.

Then

$$E = \frac{2 \pi f N \phi_{\max}}{\sqrt{2} 10^8} = \frac{4.44 f N \phi_{\max}}{10^8}$$

also

$$E = \frac{2 \pi f N A \beta_{\max}}{\sqrt{2} 10^8} = \frac{4.44 f N A \beta_{\max}}{10^8}$$

From these equations it is possible to determine any one of the unknown values when the remaining values are given. Magnetic densities in the transformer core vary over wide ranges. In modern practice the following values are in general use.

For 25 or 60 cycle transformers—densities of from 40,000 to 90,000 C. G. S. lines per square inch.

The current density in the copper winding is limited by the ability of the transformer to dissipate the heat generated therein. The radiation in turn will be affected by the design of the transformer.

**12. Ratio of a voltage or of a power transformer is the ratio of the r.m.s. primary terminal voltage to the r.m.s. secondary terminal voltage at rated load, approximately sinusoidal voltage assumed. The Ratio of a current transformer is the ratio of r.m.s. primary current to r.m.s. secondary current, at rated load, approximately sinusoidal currents assumed.**

**NOTE:** In many practical cases, particularly in the case of power transformers, it is a sufficient approximation to take the ratio as the ratio of turns, and it is this ratio that is ordinarily given on the name plate of power transformers. To specify a precise ratio for a given transformer, as may be desirable in the case of instrument transformers, it is necessary to specify frequency, wave form, voltage (or current, in the case of the current transformers) load, and power factor of the load.

Let

$E_p$  = the primary voltage in volts.

$E_s$  = the secondary voltage in volts.

$N_p$  = the primary turns on the transformer.

$N_s$  = the secondary turns on the transformer.

$I_p$  = the primary current in amperes.

$I_s$  = the secondary current in amperes.

$n$  = transformer ratio.

Then from Section 6, Article 11.

$$E_p = K N_p$$

$$E_s = K N_s$$

$$n = \frac{E_p}{E_s} = \frac{N_p}{N_s}$$

$$I_p E_p = I_s E_s$$

Therefore

$$\frac{E_p}{E_s} = \frac{I_s}{I_p} = n = \frac{N_p}{N_s}$$

The above assumes that the ratio is equal to the ratio of turns in the primary and secondary windings.

**13. Equivalent Resistance and Reactance of Transformer Coils.** In making calculations, it is often convenient to use the total equivalent resistance and reactance of a transformer rather than to

make two calculations utilizing the primary and secondary reactances and resistances separately. This total reactance and resistance may be found in the following manner:

- $E_p$  = primary voltage (assumed to be the high voltage side).
- $E_s$  = secondary voltage.
- $I_p$  = primary current.
- $I_s$  = secondary current.
- $n$  = ratio of transformation.
- $r_p$  = primary resistance.
- $r_s$  = secondary resistance.
- $r_{sp}$  = secondary resistance referred to the primary.
- $r_t$  = total resistance referred to the primary.
- $x_p$  = primary reactance.
- $x_s$  = secondary ~~resistance~~ *reactance*.
- $x_{sp}$  = secondary reactance referred to the primary.
- $x_t$  = total reactance referred to the primary.

Then neglecting magnetizing current

$$I_s = n I_p$$

$$E_s = \frac{E_p}{n}$$

The secondary percent voltage drop in terms of the equivalent primary voltage drop must be equal to the secondary percent voltage drop. Therefore

$$\frac{I_s r_s}{E_s} = \frac{r_{sp} I_p}{E_p}$$

$$\frac{I_p n r_s}{\frac{E_p}{n}} = \frac{r_{sp} I_p}{E_p}$$

$$\frac{I_p n^2 r_s}{E_p} = \frac{r_{sp} I_p}{E_p}$$

$$r_{sp} = r_s n^2$$

Similarly

$$x_{sp} = x_s n^2$$

$$r_t = r_p + r_{sp} = r_p + n^2 r_s$$

$$x_t = x_p + x_{sp} = x_p + n^2 x_s$$

**14. FEATURES OF DESIGN.** The design of transformers is affected primarily by the ultimate cost which is governed by several conditions, the most important of which are:

- 1st. The quality of the insulation between the primary and secondary windings. (Art. 15.)
- 2nd. The allowable temperature rise in the transformer during operation. (Art. 16.)
- 3rd. The efficiency of the transformer. (Art. 17.)
- 4th. The regulation of the transformer. (Art. 18.)
- 5th. Limiting the "ageing" of transformer cores. (Art. 19.)

6th. The power-factor and the exciting current. (Art. 20.)

**15. Insulation.** No feature of transformer design should be given more attention than the insulation, as on the quality and durability of this depends the life of the transformer. Aside from its initial excellence, the insulation should preserve all its properties after years of continuous use, having been subjected, in the interim, to heavy overloads and high temperatures for short periods.

Insulation may be divided into four classes:

1st. Fibrous materials, such as paper and cloth, which are used principally between the layers of wire.

2nd. Fireproof insulation, such as Mica or Asbestos.

3rd. Impregnating compounds.

4th. Transformer oil.

Of the above insulations Mica and varnished cloth are the most used. Mica, because of its high dielectric strength and fireproof quality, is particularly efficient but where short turns must be made, it is difficult to apply, as it is mechanically weak. The flexibility of varnished cloth, together with the ease with which it may be applied, makes its use in transformer insulation very general. The other materials given are, as a rule, lower in dielectric strength. They are used to a considerable extent but usually in places where mechanical separation rather than electrical insulation is desired.

In the application of these insulating materials we may distinguish between two general methods of insulation.

1st. The Impregnation Method.

2nd. The Varnish Method.

The first method is used with small windings of a large number of turns. The entire winding is impregnated with a compound which solidifies at ordinary temperatures. Only untreated material is used with this treatment, as treated insulation would keep out the impregnating compound.

The second type of insulation is used for large windings of relatively large wire and few number of turns. Treated material is used freely, as for instance, varnished cloth. The various parts of the windings are dipped in varnish and baked.

**16. Temperature.\*** There are two methods in common use for determining the rise in temperature, *viz.*: (1) by thermometer, and (2) by increase in resistance of an electric circuit.

The temperature of electrical machinery under regular service conditions, should never be allowed to remain at a point at which permanent deterioration of its insulating material takes place.

It is recommended that the following maximum values of temperature elevation, referred to a standard room temperature of 25 degrees centigrade, at rated load under normal conditions of ventilation or cooling, should not be exceeded.

**Transformers for Continuous Service.** The temperature rise

---

\* A.I.E.E. rules are in the process of revision. Revised rules should be used instead of above.

should not exceed 50 deg. Cent. in electric circuits, by resistance; and in other parts, by thermometer.

**Transformers for Intermittent Service.** In the case of transformers intended for intermittent service, or not operating continuously at rated load, but continuously in circuit, as in the ordinary case of lighting transformers, the temperature elevation above the surrounding air-temperature should not exceed 50 deg. Cent., by resistance in electric circuits and by thermometer in other parts, after the period corresponding to the term of rated load. In this instance, the test load should not be applied until the transformer has been in circuit for a sufficient time to attain the temperature elevation due to core loss. With transformers for commercial lighting, the duration of the rated-load test may be taken as three hours, unless otherwise specified.

**Reactors, Induction- and Magneto-Regulators.** Electric circuits by resistance and other parts by thermometer, 50 deg. Cent.

**Large Apparatus.** Large generators, motors, transformers, or other apparatus in which reliability and reserve overload capacity are important, are frequently specified not to rise in temperature more than 40 deg. Cent. under rated load and 55 deg. Cent. at rated overload. It is, however, ordinarily undesirable to specify lower temperature elevations than 40 deg. Cent. at rated load, measured as above.

The maintenance of low temperature in a transformer is desirable, as it prevents the ageing tendency of steel and the deterioration of the insulation. Statements regarding temperature rise, however, and the method of its determination are meaningless unless all the varying conditions attached thereto are considered. Measurements made by a thermometer to determine coil temperature are usually of little value. There is little possibility of local high temperature in any part of the winding of a small transformer where the ratio of the energy loss to the radiating surface is small. In large transformers, however, the number of watts radiated per square inch of radiating surface is considerably greater, and sections of the winding may be at a considerably higher temperature than thermometer measurements would indicate. Transformers of this type are usually provided with a liberal number of ventilating ducts located between the sections of the winding and between the windings and the core, which ducts facilitate the circulation of the oil. Corrugated transformer cases increase the radiating surface.

Transformers for pole line use are usually self-cooling. Transformers for out-of-door sub-stations are also generally self-cooling.

**17. Efficiency.** The efficiency of an apparatus is the ratio of its output to its input. The output and input may be in terms of watt-hours, watts, volt-amperes, amperes, or any other quantity of interest, thus respectively defining energy-efficiency, power-efficiency, apparent-power-efficiency, current-efficiency, etc. Unless otherwise specified, however, the term is ordinarily assumed to refer to power-efficiency.



**Apparent Efficiency.** In apparatus in which a phase displacement is inherent to their operation, apparent efficiency should be understood as the ratio of net power output to volt-ampere input.

a. **NOTE.** Such apparatus comprises induction motors, synchronous phase modifiers, synchronous converters controlling the voltage of an alternating-current system, potential regulators, open magnetic circuit transformers, etc.

b. **NOTE.** Since the apparent efficiency of apparatus delivering electric power depends upon the power-factor of the load, the apparent efficiency unless otherwise specified should be referred to a load power-factor of unity.

In **Stationary Induction Apparatus**, the losses are:

a. **Molecular Magnetic Friction and Eddy Currents** measured at open secondary circuit, rated frequency, and at rated voltage  $-I^2 r$ , where  $I$ =rated current,  $r$ =resistance of primary circuit.

b. **Resistance Losses**, the sum of the  $I^2 r$  losses in the primary and in the secondary windings of a transformer, or in the two sections of the coil in a compensator or auto-transformer, where  $I$ =rated current in the coil or section of coil, and  $r$ =resistance.

c. **Load Losses, i.e.,** eddy currents in the iron and especially in the copper conductors, caused by the current at rated load. For practical purposes they may be determined by short-circuiting the secondary of the transformer and impressing upon the primary a voltage sufficient to send rated load current through the transformer. The loss in the transformer under these conditions, measured by wattmeter, gives the load losses  $+I^2 r$  losses in both primary and secondary coils.

In **Closed Magnetic Circuit Transformers**, either of the two circuits may be used as primary when determining the efficiency.

In **Potential Regulators**, the efficiency should be taken at the maximum voltage for which the apparatus is designed, and with non-inductive load, unless otherwise specified.

The usual method of determining the efficiency at full load is to divide the full load output by the full load output, plus the sum of the power measured on open circuit test (core loss) and on short circuit test (copper loss).

Let

$\eta$  = the efficiency of the transformer in percent.

$W$  = the power output of the transformer in watts at full load.

$w_e$  = the iron losses in watts.

$w_c$  = the copper losses at full load in watts.

Then

$$\eta = \frac{100 W}{W + w_e + w_c}$$

**18. Regulation.** The regulation of a machine or apparatus in regard to some characteristic quantity (such as terminal voltage or speed) is the change in that quantity between any two loads. Unless otherwise specified, the two loads considered shall be zero

load and normal rated load. The regulation may be expressed by stating the numerical values of the quantity at the two loads, or it may be expressed as the ratio of the change in the quantity to the value of the quantity considered as normal for the machine or apparatus.

In constant potential transformers, the regulation is the difference between the no-load and rated load values of the secondary terminal voltage at the specified power-factor (with constant primary impressed terminal voltage) expressed in percent of the rated load secondary voltage.

**NOTE:** The rated current of a constant potential transformer is that secondary current which, multiplied by the full-load secondary voltage, gives the kv-a. rated output. That is, a transformer of given kv-a. rating must be capable of delivering the rated output at constant secondary voltage, while the primary impressed voltage is increased to whatever value is necessary to give constant secondary voltage.

**19. Magnetic Fatigue or the Ageing of Steel.** Transformer core loss may increase—due to the ageing of the steel in the transformer coil, particularly where the core has been continually subjected to abnormal operating temperatures.

While the cause of this phenomena has not been discovered, several very important conclusions have been drawn as the result of investigation by Mr. W. E. Goldsborough, Mr. Wm. M. Mordey and Mr. S. R. Rouget.

1st. Steel and iron when maintained at the same temperature, show very great hysteretic differences, depending upon the quality of the material.

2nd. The increase in the hysteretic loss of a given volume of iron or steel is dependent upon the temperature at which it is maintained.

3rd. Within ordinary temperature ranges the variation in this loss, due to ageing, increases with the temperature.

4th. Soft sheet steel is less subject to ageing than soft sheet iron.

5th. Sheet steel that does not age materially at temperatures below 75° C. can be obtained, but almost any iron or steel ages more or less at high temperatures. Silicon steel is practically non-ageing at working temperatures.

The values in Fig. 162 illustrate the results of a test made by Prof. Goldsborough, Purdue University, on five transformers and show the increase in transformer core loss due to ageing.

Figs. 163 and 164 illustrate the change in the core loss in steel after prolonged heating.

Fig. 165 illustrates the change in hysteretic loss due to ageing and illustrates:

1st. The original hysteretic loss of the transformer.

2nd. The effect of baking the core for nineteen (19) hours in a temperature of 200° C., indicating that after such a treatment the hysteretic loss has greatly increased.

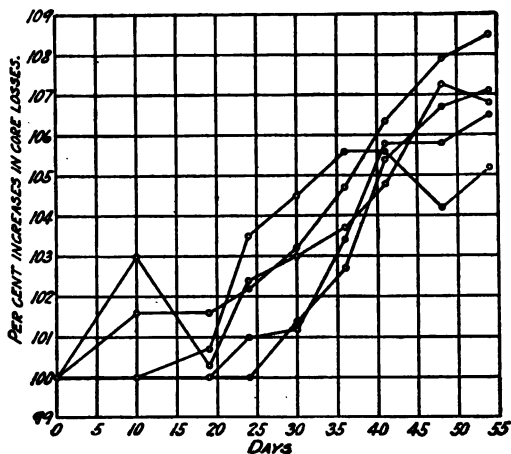

Fig. 162.—Illustrates the increase in iron loss due to ageing (tests made on 5 transformers.)

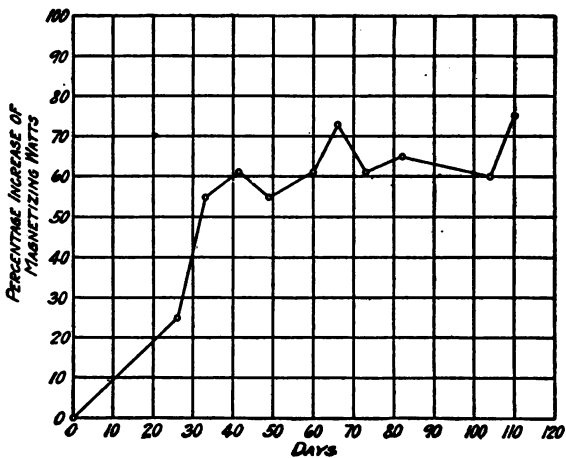

Fig. 163.—Increase in hysteresis loss of iron due to continued heating.

3rd. The effect of baking the core for four days in a temperature of 200° C., indicating a decrease in hysteretic loss which would seem to show that prolonged heating is productive to partial recovery in permeability.

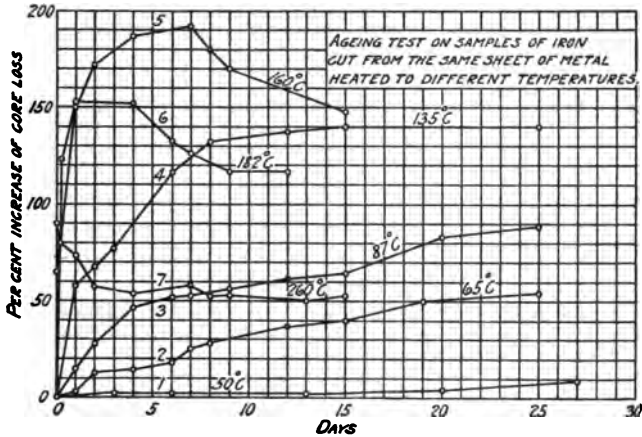

Fig. 164.

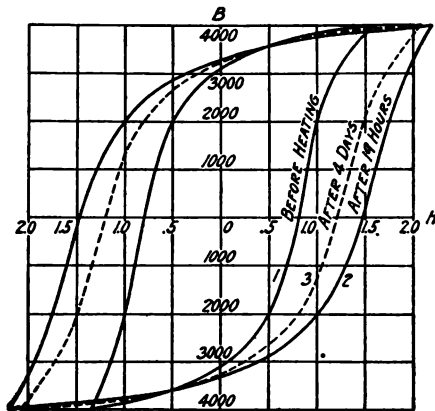

Fig. 165.

**20. Power-Factor and Reactive Factor.** The power-factor in alternating-current circuits or apparatus is the ratio of the effective (i.e. the cyclic average) power in watts to the apparent power in volt-amperes. It may be expressed as follows:

$$\frac{\text{effective power}}{\text{apparent power}} = \frac{\text{effective watts}}{\text{total volt-amperes}} = \frac{\text{effective current}}{\text{total current}} = \frac{\text{effective voltage}}{\text{total voltage}}$$

The **Reactive-Factor** is the ratio of the reactive volt-amperes (i.e., the product of the reactive component of current by voltage, or reactive component of voltage by current) to the total volt-amperes. It may be expressed as follows:

$$\frac{\text{reactive power}}{\text{apparent power}} = \frac{\text{reactive watts}}{\text{total volt-amperes}} = \frac{\text{reactive current}}{\text{total current}} = \frac{\text{reactive voltage}}{\text{total voltage}}$$

**Power-Factor and Reactive-Factor** are related as follows:

If  $p$  = power-factor and  $q$  = reactive-factor, then with sine waves of voltage and current,

$$p^2 + q^2 = 1$$

With distorted waves of voltage and current,  $q$  ceases to have definite significance.

It will be noted that for sine waves the relation between the apparent power and the effective power is a cosine relation, thus for power-factors of circuits in which the shape of the voltage and current waves are a true sine,  $\cos. \Theta$  may be used to designate the power-factor of the circuit and  $\Theta$  to designate the power-factor angle.

Let

- $\cos. \Theta$  = the power-factor of the load.
- $\cos. \Theta'$  = the power-factor of the transformer.
- $W$  = the power output of the transformer in watts.
- $w_e$  = the core loss of the transformer in watts.
- $w_c$  = the copper loss of the transformer in watts.
- $I_m$  = the magnetizing current of the transformer.
- $I_o$  = the load current of the transformer at power-factor,  $\cos. \Theta$ .
- $E$  = the effective primary voltage of the transformer.
- $x_t$  = the reactance of the transformer referred to the primary.

Then

$$\text{Tan. } \Theta' = \frac{E I_m + x_t I_o^2 + W \tan. \Theta}{W + w_e + w_c}$$

values of  $\tan. \Theta$  may be found for values of  $\cos. \Theta$  from the trigonometric tables in Section 1.

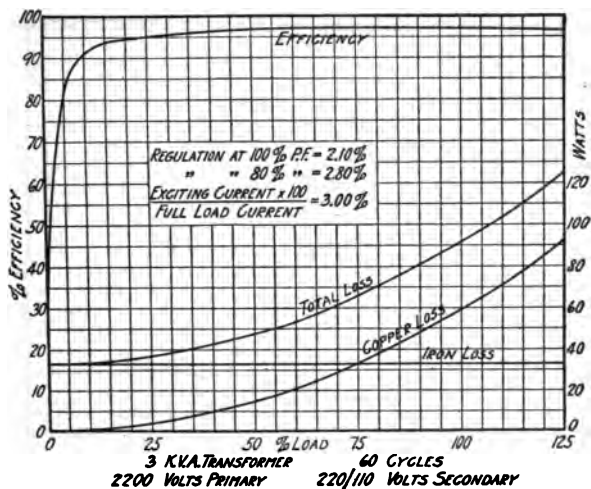

FIG. 166.

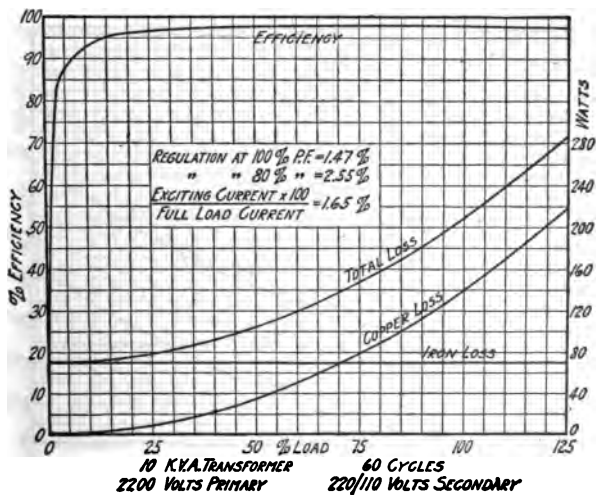

FIG. 167.

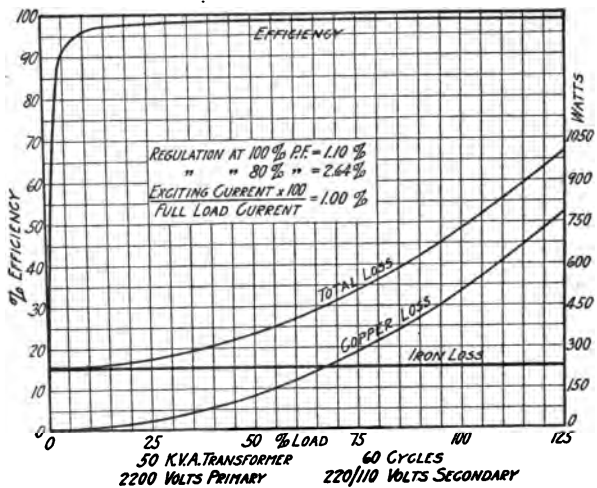

Fig. 168.

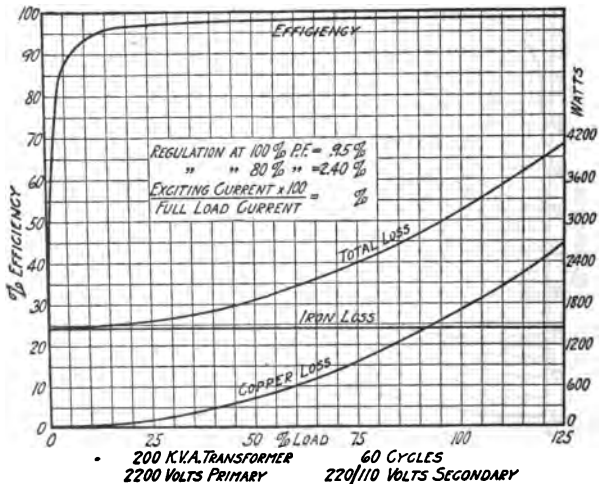

Fig. 169.

# TRANSFORMERS

## Sec. 6

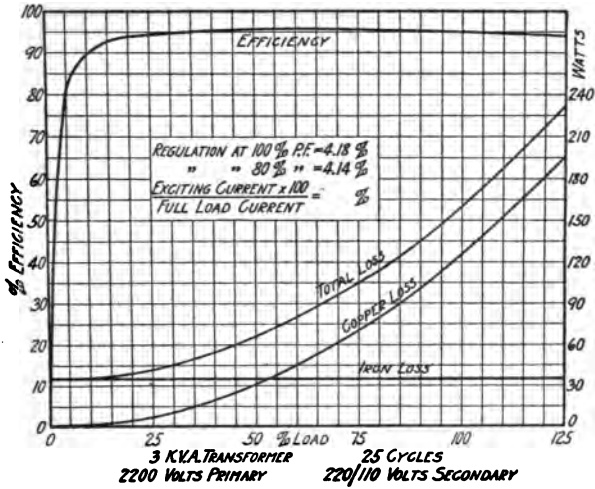

FIG. 170.

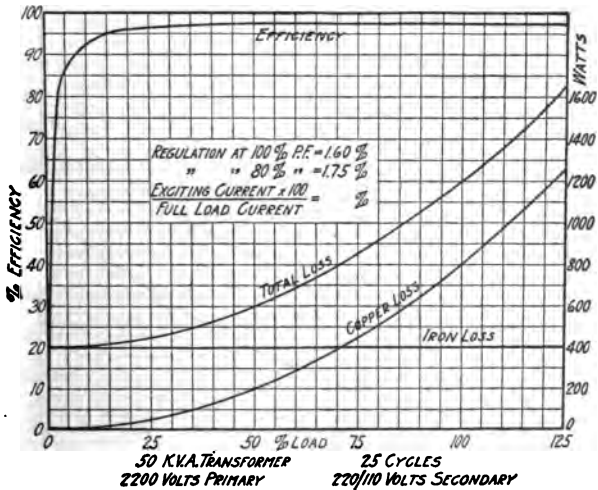

FIG. 171.



Sec. 6

TRANSFORMERS

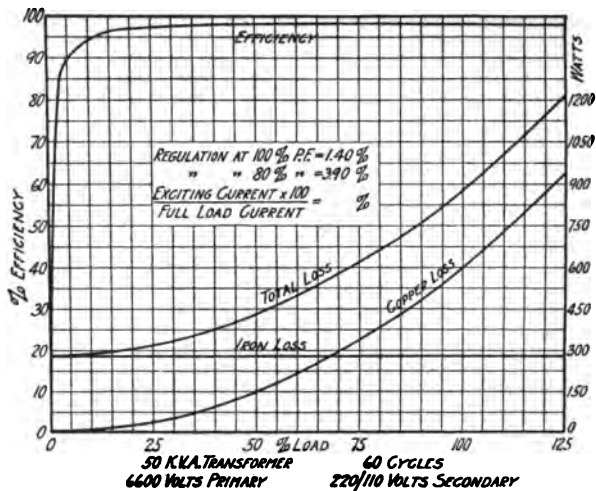

Fig. 172.

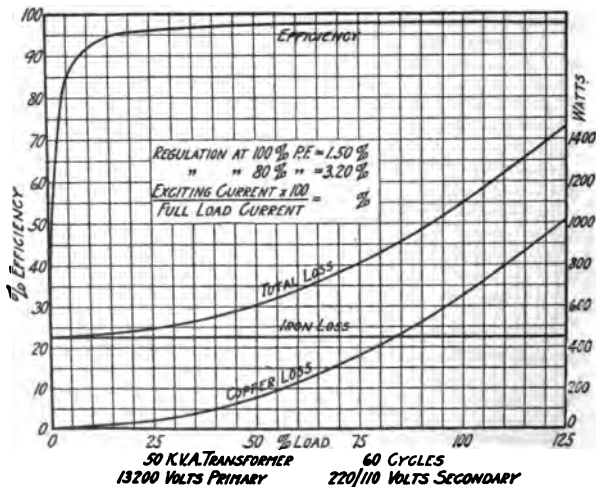

Fig. 173.

Values of the power-factor of the transformer on the primary side  $\cos.\theta'$  may be found from values of  $\tan.\theta'$  in the trigonometric tables in Section 1.

$$\text{At no-load } \tan.\theta'_o = \frac{E I_m}{w_c}$$

**21. Transformer Characteristics.** Figs. 166 to 173 inclusive illustrate the average characteristic of transformers for use on 2200, 6600 and 13,200 volt systems. The characteristics of transformers ranging in potential from 22,000 to 66,000 volts will vary approximately as follows:

The efficiency will vary with the kv-a. rating, and inversely with the voltage.

The regulation at 100% P.F., resistance drop and exciting current, will vary with the voltage and inversely with the kv-a. rating. The reactance drop will vary from 3 to 8 percent and the regulation at 80 P.F. from 2½ to 6½ percent, depending upon the kv-a. rating, voltage and frequency. The power-factor at no load will vary between the limits of 12 and 30 percent.

**22. TRANSFORMER TESTING.** The following transformer tests are not intended to illustrate shop practice, but are included as the simple accurate tests which may be made by operating companies.

- 1st. Insulation. (Art. 23.)
- 2nd. Heating. (Art. 24.)
- 3rd. Core loss and exciting current. (Art. 25.)
- 4th. Resistance. (Art. 26.)
- 5th. Copper loss. (Art. 27.)
- 6th. Reactance Drop. (Art. 28.)
- 7th. Regulation. (Art. 29.)
- 8th. Ratio. (Art. 30.)
- 9th. Polarity. (Art. 31.)

**23. INSULATION.\***

**(I) INSULATION RESISTANCE.**

**Insulation Resistance** is the ohmic resistance offered by an insulating coating, cover, material or support to an impressed voltage, tending to produce a leakage of current through the same.

**Ohmic Resistance and Dielectric Strength.** The ohmic resistance of the insulation is of secondary importance only, as compared with the dielectric strength or resistance to rupture by high voltage. Since the ohmic resistance of the insulation can be very greatly increased by baking, but the dielectric strength is liable to be weakened thereby, it is preferable to specify a high dielectric strength rather than a high insulation resistance. The high-voltage test for dielectric strength should always be applied.

---

\*A. I. E. E. rules are in the process of revision. Revised rules should be used instead of above.

**Recommended Value of Resistance.** The insulation resistance of completed apparatus should be such that the rated terminal voltage of the apparatus will not send more than  $\frac{1}{1,000,000}$  of the rated-load current, through the insulation. Where the value found in this way exceeds one megohm, it is usually sufficient.

**Insulation Resistance Tests** should, if possible, be made at the pressure for which the apparatus is designed.

## (II) DIELECTRIC STRENGTH.

### Test Voltages.

**Definition.** The dielectric strength of an insulating wall, coating, cover or path is measured by the voltage which must be applied to it in order to effect a disruptive discharge through the same.

**Basis for Determining Test Voltages.** The test voltage which should be applied to determine the suitability of insulation for commercial operation is dependent upon the kind and size of the apparatus and its normal operating voltage, upon the nature of the service in which it is to be used, and the severity of the mechanical

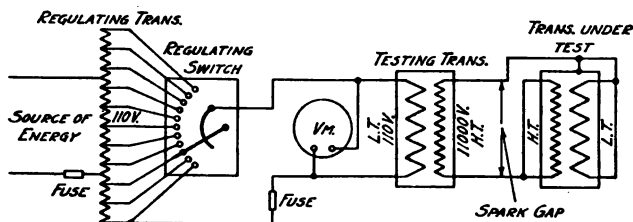

Fig. 174.—Insulation test. (Using special testing transformer.)

and electrical stresses to which it may be subjected. The voltages and other conditions of test which are recommended have been determined as reasonable and proper for the great majority of cases and are proposed for general adoption, except when specific reasons make a modification desirable.

**Condition of Apparatus to be Tested.** Commercial tests should, in general, be made with the completely assembled apparatus and not with individual parts. The apparatus should be in good condition and high-voltage tests, unless otherwise specified, should be applied before the machine is put into commercial service, and should not be applied when the insulation resistance is low owing to dirt or moisture. High-voltage tests should, in general, be made at the temperature assumed under normal operation. High-voltage tests considerably in excess of the normal voltages to determine whether specifications are fulfilled are admissible on new machines only. Unless otherwise agreed upon, high-voltage tests of a machine should be understood as being made at the factory.

**Points of Application of Voltage.** The test voltage should be successively applied between each electric circuit and all other electric circuits including conducting material in the apparatus.

The **Frequency** of the alternating-current test voltage is, in general, immaterial within commercial ranges. When, however, the frequency has an appreciable effect, as in alternating-current apparatus of high voltage and considerable capacity, the rated frequency of the apparatus should be used.

**Table of Testing Voltages.** The following voltages are recommended for testing all apparatus, lines and cables, by a continued application for one minute. The test should be with alternating voltage having a virtual value (or root mean square referred to a sine wave of voltage) given in the table, and preferably for tests of alternating apparatus at the normal frequency of the apparatus.

Rated Terminal Voltage of Circuit.	Rated Output.	Testing Voltage.
Not exceeding 400 volts.....	Under 10 kw .....	1,000 volts.
Not exceeding 400 volts.....	10 kw. and over.....	1,500 volts.
400 and over, but less than 800 volts.....	Under 10 kw .....	1,500 volts.
400 and over, but less than 800 volts.....	10 kw. and over.....	2,000 volts.
800 and over, but less than 1,200 volts.....	Any .....	3,500 volts.
1,200 and over, but less than 2,500 volts.....	Any .....	5,000 volts.
2,500 and over.....	Any ..	Double the normal rated voltages.

**Exception.—Transformers.** Transformers having primary pressures of from 550 to 5,000 volts, the secondaries of which are directly connected to consumption circuits, should have a testing voltage of 10,000 volts, to be applied between the primary and secondary windings, and also between the primary winding and the core.

**Special insulation testing transformers** should be used in making insulation tests; the diagrammatic connections of which are illustrated in Fig. 174. However, standard transformers may be connected to give the desired test voltage. When **standard transformers** are used they should be well insulated from the ground in order to protect the transformer windings.

Fig. 175 illustrates a method of connecting six standard 110—2,200 volt transformers in order to obtain 13,200 volts for testing purposes. Transformers A, B, and C, are used to insulate the remaining transformers from the source of energy, and if it is not necessary to protect the circuit they may be omitted.

When the scheme of connections illustrated in Fig. 175 is used, the lead marked O should be connected to ground and one side of the voltmeter should also be connected to ground to prevent any dangerous difference of potential from the voltmeter to the ground.

In order to prevent **over-straining** the insulation of the transformer under test, a spark gap, in series with a resistance should be connected across the test wires. The spark gap should be so adjusted that accidental over-voltage will discharge across the gap, before reaching a value injurious to the transformer insulation.

**Over-voltage** may be caused by a poor generator voltage wave form, or may be caused, when a regulating resistance is used, by the

## Sec. 6

## TRANSFORMERS

distortion of the supply voltage wave form, due to the magnetizing current of the testing transformer flowing through this resistance.

The use of a small alternating current generator, the voltage of which can be varied by a field rheostat, is preferable to the use of regulating resistance in a constant voltage supply.

The spark gap should be set in accordance with Tables. (Art 63, Sec. 7.) Should a discharge occur across needle gaps, the needle points must be renewed, as a discharge destroys their calibration.

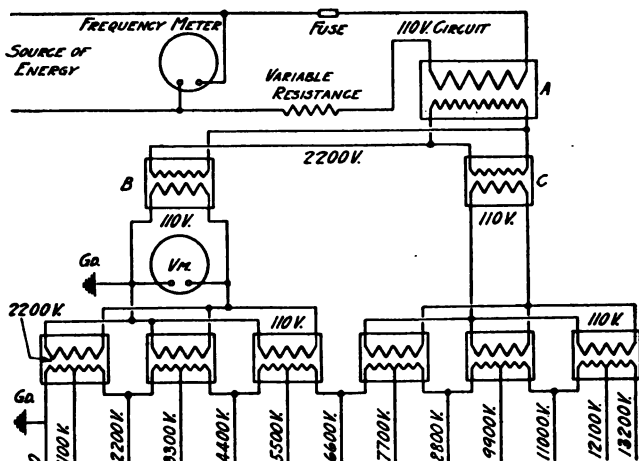

Fig. 175.—Insulation test (using standard transformers.)

The primary voltage may be found by multiplying the reading of the voltmeter  $V$  in Fig. 175, by the ratio of transformation of one transformer, times the number of transformers in series on the high potential side.

Let

$E$  = high potential voltage.

$V$  = the reading of the voltmeter on the low tension side.

$n$  = the ratio of transformation of one transformer.

$n'$  = the number of transformers in series.

Then

$$E = V n n'$$

All testing connection should be tightly made as an arc may cause undue high potential strain.

The primary and secondary leads of the transformer under test should be connected as shown in Figs. 176 and 177.

Insulation test between primary and core . . . . .	Fig. 176.
"    "    "    "    "    "    "    "    "    "    "    "    "    "    "    "    "    "	176.
"    "    "    "    "    "    "    "    "    "    "    "    "    "    "    "    "	177.

It is necessary to make the above connections, as portions of the windings not connected to the testing transformer will be subjected to induced stresses which may exceed the supply voltage. This is caused by the capacity which exists between primary and secondary windings, and between these respective windings and the core.

When the connections have been made, as illustrated in Fig. 175, close the low voltage switch and slowly adjust the alternator fields or the regulating resistance until the voltage is increased from the lowest obtainable value to a value on the voltmeter V, indicating that the voltage on the high potential side of the testing transformer has reached the desired maximum. After this voltage has been maintained for the required time, slowly decrease the voltage to the lowest value possible and open the switch.

The frequency should be maintained at approximately normal value during the test. A record of this may be obtained by in-

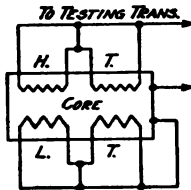

Fig. 176.

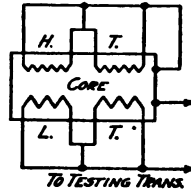

Fig. 177.

serting a frequency meter in the circuit or by determining the generator speed.

**23a. FOR MEASURING THE TEST VOLTAGE**, two instruments are in common use, (1) the spark gap and (2) the voltmeter.

1. **The Spark Gap** is ordinarily adjusted so that it will break down with a certain predetermined voltage, and is connected in parallel with the insulation under test. It ensures that the voltage applied to the insulation is not greater than the break-down voltage of the spark gap. A given setting of the spark gap is a measure of one definite voltage, and, as its operation depends upon the maximum value of the voltage wave, it is independent of wave form and is a limit on the maximum stress to which the insulation is subjected. The spark gap is not conveniently adapted for comparatively low voltages.

In Spark-Gap Measurements, the spark gap may be set for the required voltage and the auxiliary apparatus adjusted to give a voltage at which this spark gap just breaks down. The spark gap should than be adjusted for, say, 10 percent higher voltage, and

the auxiliary apparatus again adjusted to give the voltage of the former break-down, which is to be the assumed voltage for the test. This voltage is to be maintained for the required interval.

The Spark Points should consist of new sewing needles, supported axially at the ends of linear conductors which are each at least twice the length of the gap. There should be no extraneous body near the gap within a radius of twice its length. Tables of approximate striking distances are given in Sec. 7. These tables should be used in connection with tests made by the spark-gap methods.

A Non-Inductive Resistance of about one-half ohm per volt should be inserted in series with each terminal of the gap so as to keep the discharge current between the limits of one-quarter ampere and two amperes. The purpose of the resistance is to limit the current in order to prevent the surges which might otherwise occur at the time of break-down.

2. The Voltmeter gives a direct reading, and the different values of the voltage can be read during the application and duration of the test. It is suitable for all voltages, and does not introduce disturbances into the test circuit.

In Voltmeter Measurements, the voltmeter should, in general, derive its voltage from the high-tension testing circuit either directly or through an auxiliary ratio transformer. It is permissible, however, to measure the voltage at other places,—for example, on the primary of the transformer, provided the ratio of transformation does not materially vary during the test; or that proper account is taken thereof.

**Spark Gap and Voltmeter.** The spark gap may be employed as a check upon the voltmeter used in high-tension tests in order to determine the transformation ratio of the transformer, the variation from the sine wave form and the like. It is also useful in conjunction with voltmeter measurements to limit the stress applied to the insulating material.

**23b. OVER-POTENTIAL TEST.** For testing the insulation between turns, double potential at no-load for one minute is maintained. The connections for such tests are made in a manner similar to that for a core loss test except that higher voltages are used, depending upon the rated primary voltage of the transformer to be tested.

When making over-potential tests the frequency of the supply voltage should be increased in approximately the same proportions as the voltage; otherwise, the exciting current will be excessive and may be sufficient to injure the windings of transformers having a small kv-a. rating.

**24. HEATING TESTS.** There are three general methods of making heat tests on transformers, two of which approximate service conditions, the other applying actual full load to the transformer.

The first method consists of operating the transformer at full load for a definite length of time. This is never used on large

transformers, due to needless waste of energy, but may sometimes be used to advantage on small units.

Fig. 188 illustrates diagrammatically the connections necessary when loading a small transformer. Voltmeter, ammeter and frequency meter readings should be taken and adjustments made in order that the transformer may be operated under normal conditions.

Temperatures may be measured by thermometer or by resistance, using in the latter case either the Wheatstone Bridge or the Fall of Potential Method.

Resistance measurements should be made before the test is started and at different times during the test. The temperature may then be calculated from the increase in resistance as follows:

Let

$t$  = the final temperature.

$t_0$  = the initial temperature.

$r$  = the final resistances.

$r_0$  = the initial resistances.

$a$  = the temperature coefficient depending on whether  $t$  is in degrees C or F (Section 3).

Then

$$t = \frac{r(1 + a t_0) - r_0}{a r_0}$$

For copper and temperature in degrees C.

$$t = \frac{r(1 + .00428 t_0) - r_0}{.00428 r_0}$$

Necessary precaution should be taken to obtain the correct temperature of the copper when measuring the initial resistance, since a transformer taken from the outside into or transported from one room to another may have a decidedly different temperature than the room.

The temperature rise is found by subtracting  $t_0$  from  $t$ , assuming that the transformer was at room temperature when the test began. If  $t_0$  is not the standard room temperature (25° C.), then the room temperature, instead of  $t_0$ , is subtracted from  $t$ . If the room temperature is above the standard temperature of 25° C., the temperature rise is decreased one-half of one percent for each degree that the room temperature is above 25° C. If the room temperature is below 25° C. one-half of one percent is added for each degree that the room temperature is below 25° C.

**Temperature Correction.** Assuming the room temperature during test is 30° C. and the measured temperature rise is 40° C. the actual temperature rise is found as follows:

$$\begin{aligned} 30^\circ \text{ C.} - 25^\circ \text{ C.} &= 5^\circ \text{ C.} \\ 5^\circ \text{ C.} \times \frac{1}{2}\% &= 2\frac{1}{2}\%. \\ 2\frac{1}{2}\% \times \frac{40}{100} &= 1^\circ \text{ C.} \end{aligned}$$

\*A. I. E. E. Rules are in the process of revision. Revised rules should be used instead of above.



## Sec. 6

## TRANSFORMERS

Therefore the correct temperature rise is

$$40^{\circ} \text{C.} - 1^{\circ} \text{C.} = 39^{\circ} \text{C.}$$

**Barometric Pressure.\*** A barometric pressure of 760 mm. and normal conditions of ventilation should be considered as standard, and the apparatus under test should neither be exposed to draught nor enclosed, except where expressly specified. The barometric pressure needs to be considered only when differing greatly from 760 mm.

**Barometric Pressure Correction.\*** When the barometric pressure differs greatly from the standard pressure of 760 mm. of mercury, as at high altitudes, a correction should be applied. In the absence of more nearly accurate data, a correction of one percent of the observed rise in temperature for each 10 mm. deviation from the 760 mm. standard is recommended. For example, at a barometric pressure of 680 mm. the observed rise of temperature is to be reduced

$$\text{by } \frac{760 - 680}{10} = 8 \text{ percent.}$$

In the second method energy equal to the losses only is supplied. It requires the use of two similar transformers connected as illustrated in Fig. 178. Circuit A supplies energy equal to the iron

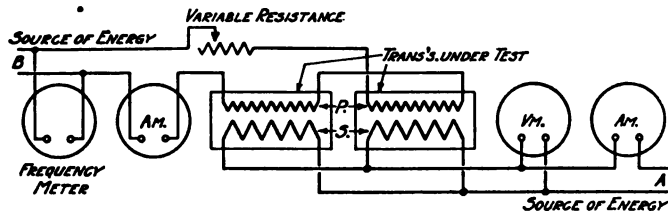

FIG. 178.—Heat test of two similar single-phase transformers. (Losses only supplied.)

losses in the transformers. Circuit B circulates full load current through the windings. It is general practice to magnetize the transformer on the low voltage side and introduce the circulating current on the high voltage side, as this method permits the use of standard voltages, whereas the reversed conditions would necessitate a high voltage on the primary side with a very low voltage on the secondary side, resulting in many complications in the apparatus necessary for testing.

The voltage required on circuit A is that of the rated secondary voltage of the transformer coil.

The voltage required on circuit B is double the impedance voltage of one transformer.

The total energy required in circuit A is that equal to the full load iron losses of both transformers.

The total energy required in circuit B is that equal to the full load copper losses of both transformers.

If the transformers under test are 2,200–220 volts, 220 volts is required on the secondary side and approximately 220 volts is required on the primary side. These voltages may be reduced to 110, by connecting both the primary and the secondary windings of each transformer in parallel.

If a three phase transformer or three single phase transformers are to be tested, connections may be made as illustrated in Fig. 179. This is exactly similar to that illustrated in Fig. 178 with the ex-

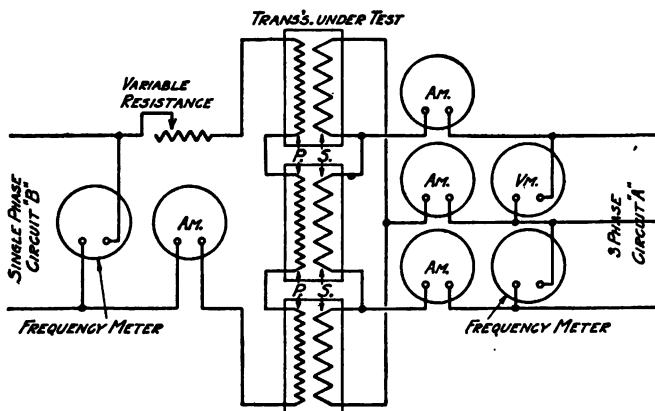

Fig. 179.—Heat test of three similar single-phase or one three-phase transformer on a three-phase circuit. (Losses only supplied.)

ception that it has been altered so as to conform to the requirements of three phase connections.

It will be noted in both Figs. 178 and 179 that the copper loss and iron loss currents are not equal in all the transformer windings. In Fig. 178 it is the vector sum in one winding and the vector difference in the other winding, depending upon the phase relation of circuits A and B. In Fig. 179, it is the vector sum or the vector difference of the iron loss and copper loss currents depending upon the phase relations of circuit B to the various phase voltages of circuit A. However, the difference in heating is so small that it is negligible. The calculations of temperature rise may then be made as described in the first method.

**3rd Method.** When one transformer only is to be tested, it is possible to apply full load current to the primary and secondary

winding without wasting any energy except that incident to the losses in the transformer. This presupposes that circuits of voltages equal to the primary and secondary voltage of the transformer are available. By inserting an induction regulator in the primary or the secondary circuit, it is possible to regulate the transformer voltage so that full load current will flow through the transformer windings. (Fig. 180.) If circuits of these required voltages are not available, a transformer of larger capacity can be used (Fig. 181).

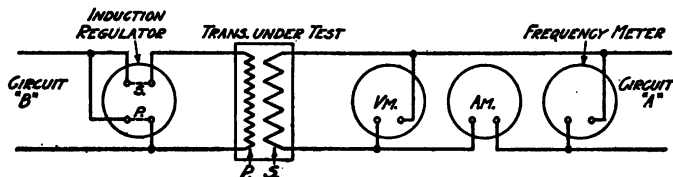

FIG. 180.—Heat test of single-phase transformer when circuits are available having the same voltage as the primary and secondary windings. (Losses only supplied.)

If the primary and secondary windings of a transformer are divided into two or more sections, energy equal to the full load copper losses of the transformer may be supplied as illustrated in Fig. 182, (circuits A and B). Energy equal to the iron losses of the transformer may be supplied as illustrated in Fig. 183.

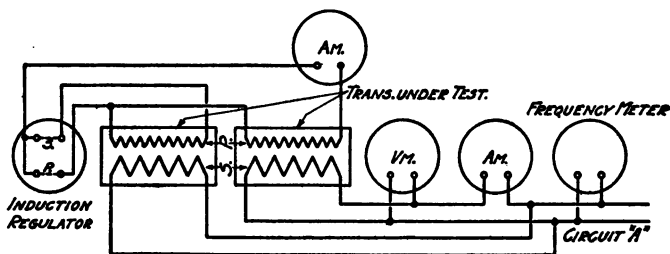

FIG. 181.—Heat test of single-phase transformer using induction regulator and testing transformer. (Losses only supplied.)

These two connections are alternately made and maintained in order to artificially create heating in the transformer equal to that which would occur at full load under operating conditions. This test is called the **compromise test**.

To obtain the equivalent heating of full load losses in a transformer it is necessary to increase the copper and iron losses to values much higher than normal. This is necessary because of the fact that

their heating effects are not superimposed and must be increased to give the same average value.

The standard connections may also be used for the compromise test (Figs. 183 and 187).

**25. CORE LOSS AND EXCITING CURRENT TESTS.** Connections for the core loss tests are illustrated in Fig. 183. This test is made at the normal operating voltage of the transformer, less the voltage loss due to the load current in the primary.

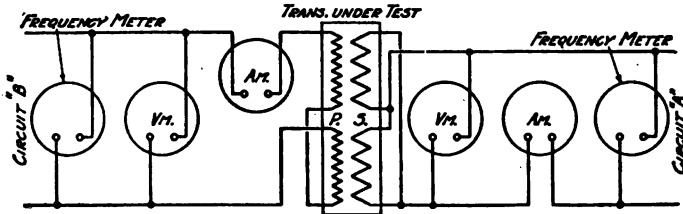

FIG. 182.—Connections that may be used in copper loss test, in connection with the compromise heat test.

voltage adjustments are made by means of a variable resistance, the core loss of the transformer may be as much as 12% in error, depending upon the shape of the voltage wave impressed upon the transformer. It is, therefore, necessary to use some means of correcting for this wave distortion, or else use a source of energy supply in which the voltage is a pure sinusoidal wave. As tests on low voltage line transformers are usually made by using a source of

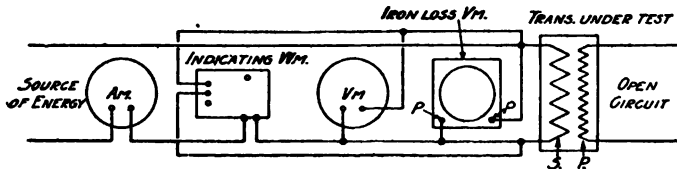

FIG. 183.—Iron loss test.

supply which cannot be independently controlled, the transformer is adjusted for the proper voltage by means of a rheostat. When this is done an iron loss voltmeter should be inserted in the circuit as shown in Fig. 183, and the voltage adjusted until the iron loss voltmeter records the operating voltage of the transformer. Readings of the wattmeter and ammeter then indicate the uncorrected value of the exciting current and iron loss. The magnetizing current may be calculated by the method given in Section 7, Article 49.

The frequency should be maintained at a constant value during this test. The wattmeter reading should be corrected for the power loss in the voltmeter and iron loss voltmeter by subtracting the losses in these instruments from the wattmeter reading. The losses in the iron loss voltmeter are indicated on a watt scale and those of the voltmeter are  $\frac{E^2}{R}$ .

**25a. Iron Loss Voltmeter.** The iron loss voltmeter is essentially a wattmeter arranged to read the iron loss of a standard iron circuit which is a part of this instrument. Variations in wave shape effect the iron loss in the standard core C. (Fig. 184.) If the wattmeter is calibrated to read directly in volts and an adjustment of the supply voltage is made until the desired voltage is read on this wattmeter scale, the iron loss is equivalent to the iron loss produced by a sine wave of the same effective value as the value indicated by the wattmeter scale. This type of instrument permits the testing of transformers on any commercial circuit, and the results

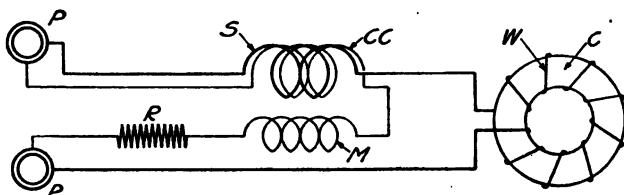

FIG. 184.—Internal connections of iron loss voltmeter.

obtained are the same as though the test were made under true sine wave conditions. Fig. 184 shows the diagrammatic connections of an iron loss voltmeter. C is the standard laminated core on which a winding W is placed. Connections from this winding pass through a stationary coil S to the terminals P P, which are connected to the supply voltage mains, as shown in Fig. 183. The shunt circuit consists of a moving coil M in series with a non-inductive resistance R and the compensating coil C C which is wound parallel to the series coil S and of an equal number of turns. This is essentially a wattmeter movement and it can readily be seen that the deflection of the wattmeter moving coil M will be caused by the total input to the instrument. This input is the hysteric and eddy current loss in the standard iron circuit C and in addition the copper losses in the winding W and the winding of the wattmeter movement.

Before calibrating the instrument for a certain frequency the adjustment of the ratio of the eddy current losses in the ring, plus the shunt copper loss to the total loss, is made by changing the non-inductive resistance in the shunt circuit and the turns on the ring. This ratio of R P loss to the total loss is made to be about 20% at

about two-thirds of the full scale voltage. After this adjustment is made, the instrument is calibrated in parallel with an alternating current voltmeter on a pure sine wave voltage of the required frequency from a small smooth core alternator. The scale of the wattmeter is drawn to agree with the readings of the alternating current voltmeter. This wattmeter measuring the iron loss of the standard iron core will always read the watts loss in the iron core independent of wave shape. Therefore, if the supply voltage is so adjusted that correct voltage indications are given on the iron loss voltmeter scale, the watts consumed by the standard core are the same as for a pure sine wave of equal value. The dotted curves in Fig. 185 illustrate the errors for variation in wave form when using a square root of mean square voltmeter to regulate the voltage for the iron loss tests on transformers with characteristics recorded in Table 56. The full line curves represent the error when using an iron loss voltmeter. With a variation of 10% in frequency there will not be an error in loss greater than 1½%.

Core losses should always be measured on the low tension side of the transformer to avoid using a high potential test circuit.

TABLE 56

Curve	Transformer with	Tested with
A	14% eddy loss	R. m. s. voltmeter
B	20% eddy loss	R. m. s. voltmeter
C	30% eddy loss	R. m. s. voltmeter
D	14% eddy loss	Iron loss voltmeter
E	20% eddy loss	Iron loss voltmeter
F	30% eddy loss	Iron loss voltmeter

**26. RESISTANCE MEASUREMENTS.** The resistance of a circuit varies with temperature, and for comparative purposes all values for resistance are corrected in order to indicate the true resistance at a temperature of 25° C. Methods of correcting for temperature are illustrated in Section 3, Art. 19.

The resistance of the coils of a transformer may be determined by the use of a **Wheatstone Bridge**, or by **The Fall of Potential Method**.

When resistance values are determined by the **Wheatstone Bridge** no corrections other than for temperature are necessary. This method is seldom used for measuring resistance values of less than one or two ohms.

**The Fall of Potential Method**, as commonly used, necessitates the use of direct current, as the inductive effect of alternating current will prevent the determination of accurate results.

Fig. 186 illustrates diagrammatically the circuit arrangement necessary when determining resistance by **The Fall of Potential**

**Method.** The illustration applies to the measurement of the resistance of the secondary coils, but is equally applicable to the measurement of the resistance of the primary coils.

When measuring resistance by the fall of potential method, the voltmeter pointer may show a continued tendency to vibrate, due to the changing magnetic field (building up) in the transformer core. To eliminate this, the opposite winding should be short circuited. Remove the short circuit before changing value of current for a second or third reading.

Corrections must be made for the current flowing through the voltmeter, which value varies in accordance with its resistance.

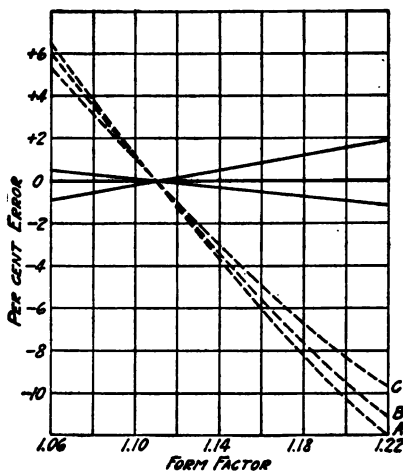

FIG. 185.—Error in measured iron loss with variation in form-factor of voltage wave.

The following formula will give the correct value for the resistance of the coil under test.

Let

$R$  = the resistance of transformer coil under test.

$R'$  = the resistance of the voltmeter.

$E$  = the voltmeter reading.

$I$  = the ammeter reading.

$I_v$  = the current flowing through the voltmeter.

$I_c$  = the corrected current or the actual current flowing through the coil under test.

$$I_v = \frac{E}{R'}$$

$$I_c = I - I_v$$

Therefore the resistance of the coil under test is

$$R = \frac{E}{I_c}$$

When measuring the resistance of a large transformer the ratio of  $I_v$  to  $I$  is negligible.

With the resistance of both primary and secondary windings known, it is possible to calculate the copper loss  $P_R$  of the transformer in each winding; and the sum of these should correspond very

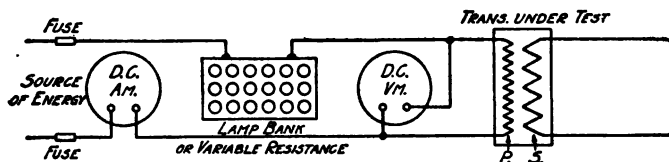

Fig. 186.—Measurement of resistance by the fall of potential method.

closely to the copper loss of the transformer as measured by a wattmeter.

When making tests in accordance with the connections shown in Fig. 186, the following procedure should be applied:

Close the switch and regulate the controlling resistance until full load current is obtained.

Read the voltmeter and ammeter.

Increase the resistance until a lower value of current is obtained, then also read the instruments.

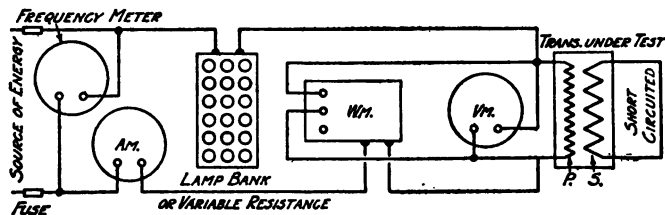

Fig. 187.—Copper loss or impedance test.

Take several readings on each coil at different current values.

Disconnect voltmeter before opening circuit.

Reduce the current to a minimum before opening the switch.

The current should flow through the transformer windings for as short a time as is possible, as the heating produced will appreciably affect the values of the resistance obtained.

**27. COPPER LOSS TEST.** It is usual to measure the impedance drop and the copper loss of a transformer on the high voltage side, for on the high voltage side more accurate voltage readings can be



obtained. The connections for a copper loss test are illustrated in Fig. 187 and indicate all the meters that are required. If extreme accuracy is desired, the wattmeter and the ammeter readings must be corrected for the current taken by the voltmeter and the wattmeter potential winding. The wattmeter reading may be corrected by subtracting the energy absorbed by the potential coils of the wattmeter and voltmeter. The value of the absorbed energy may be obtained by multiplying the square of the voltage indicated by the sum of the reciprocals of the resistance of the voltmeter and voltage coils of the wattmeter. The result subtracted from the wattmeter reading will give the input to the transformer in watts. The ammeter indicates not only the current in the transformer but also the current flowing through the potential coil of the wattmeter and voltmeter. Therefore, the amount of current indicated is slightly greater than that actually flowing through the transformer coils. However, this is practically negligible. The corrected wattmeter readings, taken when the voltage has been adjusted so that full load current flows through the ammeter, will give the sum of the full load copper losses in the primary and secondary coils of transformer.

During the test, the frequency should be maintained at a constant value.

**28. REACTANCE DROP.** The reactance drop of a transformer may be calculated in accordance with the formulae following:

Let

$E$  = the voltmeter reading, Fig. 187.

$I$  = the ammeter reading, Fig. 187.

$W_e$  = the corrected wattmeter reading, Fig. 187.

$x$  = the total reactance of the transformer windings referred to the primary, in ohms.

$z$  = the total impedance of the transformer windings referred to the primary, in ohms.

$r_p$  = the resistance of the primary winding of the transformer, in ohms.

$r_s$  = the resistance of the secondary winding of the transformer, in ohms.

$r_t$  = the total resistance of the transformer windings referred to the primary, in ohms.

$n$  = the ratio of transformation.

$f$  = the frequency in cycles per second.

The reactance may be found by two methods:

$$\text{1st. } z = \frac{E}{I} \text{ from copper loss test.}$$

$$r_t I = \frac{W_e}{I} \text{ from copper loss test.}$$

$$r_t = \frac{W_e}{I^2}$$

$$x = \frac{\sqrt{E^2 - r_t^2 I^2}}{I} = \sqrt{z^2 - r_t^2}$$

$$\begin{aligned} \text{2nd. } z &= \frac{E}{I} \text{ from copper loss test.} \\ r_t &= r_p + n^2 r_s \text{ from resistance test.} \\ x &= \frac{\sqrt{E^2 - r_t^2 I^2}}{I} = \sqrt{z^2 - r_t^2} \end{aligned}$$

The various values necessary in this calculation are obtainable in accordance with the methods described herein.

In both formulae given, the **inductance** of the transformer coils referred to the primary may be found as follows:

$$L = \frac{x}{2 \pi f} \text{ henries}$$

From the values of resistance and reactance thus obtained, the regulation of the transformer for any power factor may be obtained. (Section 7, Article 49.)

**29. REGULATION.** The regulation of a transformer may be obtained by calculation as given in Sec. 7, Article 49, or on small transformers it is possible to measure the regulation directly by connecting the transformer to a constant voltage source, Fig. 188, and

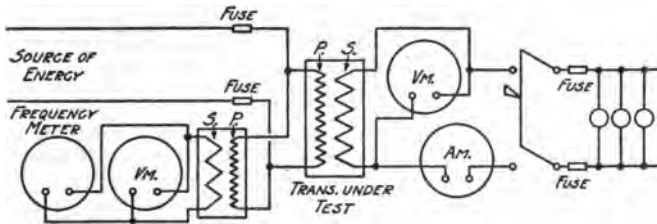

Fig. 188.—Connections for regulation test.

loading it to its full capacity with a lamp bank or other non-inductive resistance. The secondary voltage of the transformer at full load and at no load is then determined, and the difference between these values divided by the secondary voltage at full load, multiplied by 100, gives the regulation in percent.

The regulation of a transformer on a non-inductive load is about 2%; therefore, this method of obtaining regulation is not very accurate, as an error in the voltage readings of 1% will result in an error of approximately 50% in the measured regulation. Much more accurate results may be obtained by calculation.

**30. RATIO.** In order to guard against possible mistakes in coil winding and assembling, a test should be made to accurately determine the ratio of the primary to the secondary voltage. This may be done by connecting the transformer under test to a transformer of known ratio as illustrated in Fig. 189. The readings of the voltmeter will give the ratio of the transformer under test.

## Sec. 6

## TRANSFORMERS

Any convenient voltage readings large enough to obtain the desired accuracy may be used.

Let

$E_o$  = the secondary voltage of the standard transformer.

$n_o$  = the ratio of the standard transformer.

$E'$  = the secondary voltage of the transformer under test.

$n'$  = the ratio of the transformer under test.

Then

$$n' = \frac{n_o E_o}{E'}$$

**31. POLARITY.** The phase relation between the transformer primary and secondary terminal electromotive forces is termed the polarity of the transformer.

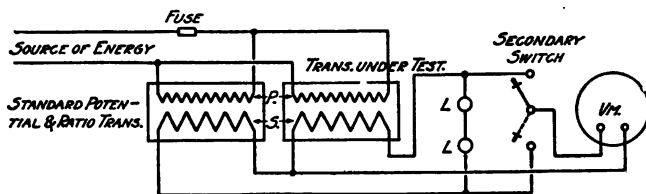

FIG. 189.—Connections for ratio test.

When the windings of a transformer are so connected that the instantaneous flow of current is into terminal A and out of terminal C, then if A is considered positive, C, Fig. 190, is also positive.

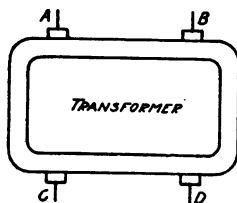

FIG. 190.

(A) The polarity of a transformer may be determined when determining the ratio by connecting the transformers under test as illustrated in Fig. 189. If the polarity is the same as that of the standard transformer the lamps will both be bright. If it is the opposite, the lamps will both be dark.

(B) The polarity of a transformer may also be determined by connecting a direct current source of energy to the low tension wind-

ing, breaking this connection and noting the deflection of a direct current voltmeter connected to the high tension winding. If the deflection on the voltmeter scale is positive, the lead of the transformer connected to the positive terminal of the voltmeter is a positive lead, and the terminal of the low voltage side connected to the negative wire of the direct current supply is also positive.

(C) Polarity may be determined by the method shown in Fig. 191. If 220 volts a-c. is supplied to the high voltage winding of a transformer with a ratio of 10 to 1, the voltage of the low voltage winding is 22. If B and D are connected, a voltmeter connected to A and C will, when the transformer is of positive polarity, read the difference between the impressed voltage and the induced voltage, or  $220 - 22 = 198$  volts. If, however, the transformer polarity is negative, then the voltmeter connected to A and C will read the sum of the impressed and induced voltages, or 242 volts.

Polyphase transformers may be tested for polarity in a manner similar to that for single phase transformers; more satisfactory

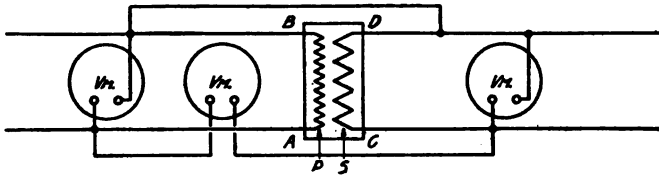

FIG. 191.—Connections for polarity test.

results are obtained by testing each phase of the transformer separately.

### TRANSFORMER SPECIFICATIONS

32. **Transformers.** In purchasing transformers definite values for the following data should be obtained:

1. Kv-a. capacity of transformer.
2. Power factor of load.
3. Primary voltage of transformer.
4. Secondary voltage of transformer.
5. Frequency of system.
6. Single phase or polyphase transformers.
7. Efficiency at  $\frac{1}{4}$ ,  $\frac{1}{2}$ ,  $\frac{3}{4}$ , full and  $1\frac{1}{4}$  full load.
8. Regulation at full load and power-factor given in item 2.
9. Core loss.
10. Exciting current.

33. **Transformer Oil.** As there is some variation in manufacturers' oil specifications, two different specifications are given.

The first specification was obtained from the Westinghouse Elec-

## Sec. 6

## TRANSFORMERS

tric & Manufacturing Company, and the specification contained in Table 57 from the General Electric Company.

### Transformer Oil Specification.

**Quality:** The oil must be a pure mineral oil obtained by fractional distillation of petroleum, unmixed with any other substances. It must not contain moisture, acid, alkali, or sulphur compounds.

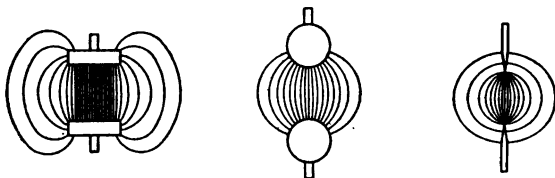

Fig. 192.—Distribution of electrostatic field for different shaped terminals.

**Flash and Fire:** The flash point of the oil must not be less than 171° C. (340° F.) and the fire point must not be less than 198° C. (390° F.).

**Evaporation:** The oil must not show a loss by evaporation of

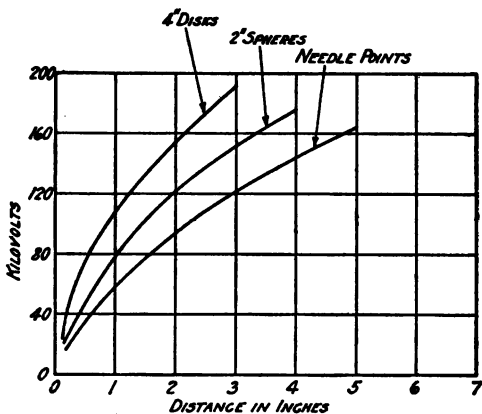

Fig. 193.—Disruptive value of dry oil for different shaped terminals.

more than twenty-five hundredths of one percent (0.25%), after heating for eight hours at a temperature of 100° C.

**Insulation:** The oil must show an average breakdown test of not less than 35,000 volts on a 0.15" gap.

**Color:** It is desirable that the color of the oil be as light as possible.

**Viscosity:** It is desirable that the oil be as fluid as possible, low viscosity being a point in its favor.

**Deposit:** The oil must not show a deposit or any change other than a darkening of color, after being raised to a temperature of 232° C. (450° F.) by heating gradually and uniformly for one hour and then allowing it to stand at room temperature for twelve hours.

The break-down voltage of oil is affected by the shape of the testing terminals. The electrostatic field between discs, spheres and needle points is illustrated in Fig. 192. The disruptive voltage of dry oil measured between variously shaped terminals is given in Fig. 193. There are two standard methods for testing the dielectric strength of oil.

**1st. method.** This method consists of testing terminals made of 1/2" brass balls fastened to 1/8" rods. These terminals are placed vertically in a glass tube and so arranged that they may be adjusted for different distances, 0.15" usually being considered standard. With this gap spacing average dry oil should not break down at less than 35,000 volts with a sine wave e.m.f.

**2nd. method.** This method consists of two half-inch brass discs, mounted on 3/8" rods and arranged horizontally in a receptacle holding oil. The discs may be adjusted for different distances, although 0.2" has been adopted as standard. With this gap spacing dry oil should not break down at less than 30,000 volts, with a sine wave e.m.f.

Table 57 gives the characteristics of two oils furnished by the General Electric Company. The No. 8 oil is used for water-cooled and oil-cooled transformers and is designed for a normal temperature rise not to exceed 40° C. The No. 12 oil is for oil-cooled apparatus when the operating temperature rise is about 40° C. The dielectric strength of these oils is 30,000 volts when the test is applied between two 1/2" discs set 0.2" apart.

<b>TABLE 57</b>		
<b>TRANSFORMER OIL</b>		
	No. 8 Oil	No. 12 Oil
Flashing Temperature .....	130° C.	160° C.
Burning Temperature .....	145° C.	175° C.
Freezing Temperature .....	-15° C.	-10° C.
Specific Gravity (15.5° C.) .....	0.830	0.850
Viscosity (40° C.) .....	40	60

**33a Moisture in Oil.** Moisture in oil may be detected by testing samples obtained from the bottom of the transformer case. If water is present in large quantities it will be apparent to the eye.

If present in small quantities it may be detected by inserting in the oil an iron wire heated to a temperature slightly below a dull red; a very decided hissing or crackling sound will indicate the presence of moisture. If moisture is present copper sulphate crystals finely pulverized and placed on a watch crystal will turn a very deep blue when covered with the oil under test. The best test, however, is a test of dielectric strength by the spark gap methods mentioned above.

Fig. 194 shows the effect of various percentage of water in medium and Fig. 195 in light oil.

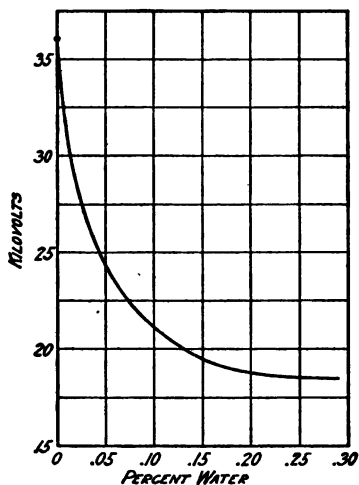

Fig. 194.—Influence of moisture on the dielectric strength of oil of medium viscosity.

**34. THE OPERATION OF LARGE vs. SMALL TRANSFORMERS.** The capacity of transformers for pole line used is limited, not only because of the mechanical problem of properly supporting them, but also because of the limited distance to which low tension current can be economically transmitted.

Large installations of light or power usually require individual transformers, but when it is possible to select a load center from which a number of relatively small consumers can be economically reached, a considerable saving in investment and in energy loss can be effected. Relatively small transformers connected to a number of small individual loads usually require a transformer capacity of approximately 80% of the connected load. Relatively large transformers connected to a number of small consumers usually require a transformer capacity of from 30% to 50% of the connected load.

This reduction in transformer capacity necessary per kw. connected load is due to the diversity factor of the individual loads connected, and in a distributing system is one of the most important problems encountered.

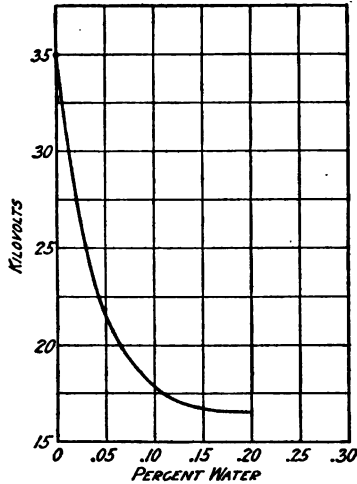

FIG. 195.—Influence of moisture on dielectric strength of light oil.

It is self-evident that the grouping of loads on a single transformer can be overdone, in that, when the secondary distribution is extended for great distances from the transformer, the cost of copper will more than offset the transformer economies. Therefore, this problem must be studied locally, giving due consideration to the character of the individual loads, their distance apart and the saving in transformer investment and in transformer efficiency that may be effected as illustrated by the following.

A relatively large transformer is superior to a number of relatively small transformers having the same total capacity, since

- The cost per kv-a is less;
- The core loss per kv-a is less;
- The copper loss per kv-a is less.

Increased economy in distribution may be effected by the parallel operation of transformers connected to a net work as illustrated in Article 8, Section 7.

**35. A POLYPHASE TRANSFORMER** is a single unit designed to transform polyphase energy to polyphase energy.

Polyphase transformers are lighter in weight and cost less per



kv-a than single-phase transformers of equal total capacity, but the failure of one section of a polyphase transformer necessitates removing it from the line. If single-phase units are used, one transformer can be readily replaced in case of damage. Therefore, when polyphase transformers are used, it is necessary to carry a more expensive reserve stock than would be necessary if single-phase transformers are used. These factors usually decide in favor of single-phase transformers.

**36. PARALLEL CONNECTING OF TRANSFORMERS.** When connecting transformers for parallel operation it is generally advisable to test the **polarity** of the various transformers before permanent connections are made. This may be done by connecting the **primary leads** of all the transformers to the primary circuit.

The **secondary leads** of one of the transformers are then connected to the secondary mains, establishing secondary voltage or voltages to which the secondary voltages of the other transformers must conform. This is determined as follows:

Connect one lead of each of the remaining transformers to one of the secondary mains. The remaining transformer secondary leads may be connected to the other secondary mains, provided voltage does not exist between the lead and the main to which it is to be connected. This condition may be determined by either a voltmeter or a lamp.

When the polarity of **single-phase** and **two-phase** transformers is known, the connections can be readily determined. The phase relation of **three-phase** transformers or of **single-phase** transformers connected to a **three-phase** system is complicated and therefore vector diagrams are given in order to show the phase relation existing in the more important connections.

In the following illustrations each transformer lead is identified by a number which is placed on the vector diagram to indicate the transformer lead which that particular end of the vector represents; thus, in Fig. 196 the vertical line on the left hand side illustrates the

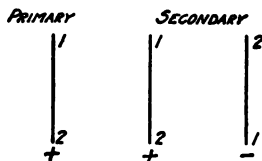

FIG. 196.

primary winding. If the polarity of the corresponding secondary winding is positive, the numbers indicating the respective ends of the vector for the same phase relation will be identical. If the polarity, however, is the reverse or negative, then the numbers on the ends of the vectors are reversed, indicating that the phase relation

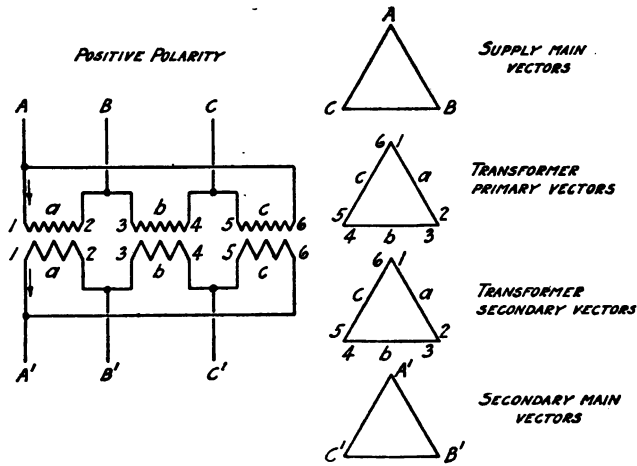

Fig. 197.—Transformers connected "Δ" primary and "Δ" secondary.

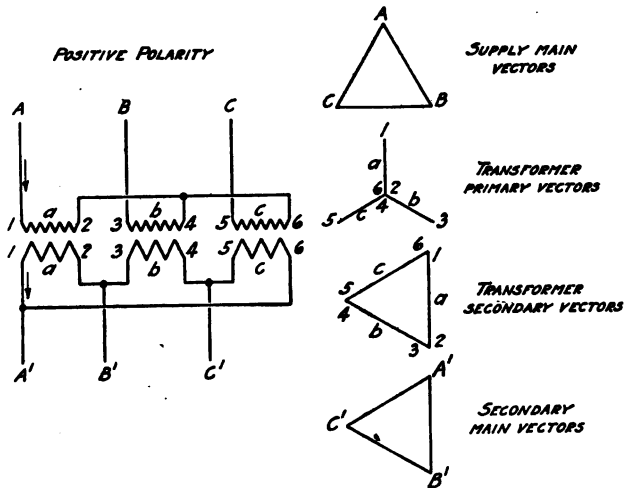

Fig. 198.—Transformers connected "Y" primary and "Δ" secondary.

of the corresponding secondary leads is opposite that of the primary leads.

The voltage between the supply mains is used as a basis of reference, as this voltage is independent of the method used in connecting the apparatus to the source of energy. Therefore, in Fig. 197 the voltages between A, B and C are " $\Delta$ " voltages. All vectors are assumed to rotate in a counter-clock-wise direction. Lead 1 of transformer a is connected to supply main A. Lead 2 of transformer a is connected to supply main B. Therefore the phase relation of transformer a is the same as that of the voltage between supply mains A and B. In a like manner transformers b and c have the same phase relation respectively as the voltages between supply mains B-C and A-C. These transformers are assumed to have positive polarity. Therefore, the voltage vectors between the secondary leads of the transformers will be in phase with their respective primary voltages and the phase relation of the voltages between secondary mains A', B' and C' will be the same as between supply mains A, B and C. This method of connection is known as the delta delta connection. If the ratio of transformation is one to one, A may be connected to A', B to B' and C to C'.

The connections in Fig. 201 are similar to those in Fig. 197, but negative transformer polarity has been assumed. Therefore, as the voltages are  $180^\circ$  out of phase, it is impossible to parallel these transformer banks with symmetrical connections. By comparing the secondary vectors of Figs. 197 and 201, it will be noted that, although the vector representing the voltage of transformer a, Fig. 197, bears the same angular relation to that representing the voltage of the transformer a, Fig. 201, it is reversed and the delta voltages are reversed.

If the secondary leads of each one of these transformers be reversed, the vector relation of the secondary voltage becomes the same as that shown in Fig. 197 (compare Fig. 202). The crossed leads thus compensate for the negative polarity and make it possible to connect this bank in parallel with that shown in Fig. 197.

Transformers may be connected with the primary in Y and the secondary in  $\Delta$  as shown in Figs. 198 and 203. In Fig. 198, which is for positive polarity, No. 1 lead of transformer a is connected to the supply main A, No. 3 lead of transformer b is connected to the supply main B, No. 5 lead of transformer c is connected to the supply main C. Leads 2, 4 and 6 are connected together. Therefore, their vector relations are as illustrated for the transformer primary vectors. The voltage in each transformer secondary coil is in phase with the primary voltage and since lead No. 2 is connected to lead No. 3, lead No. 4 to No. 5 and lead No. 6 to No. 1, the voltages of the transformer secondary will be as illustrated in the diagram. Therefore, the voltages between A', B' and C' are in phase with the secondary voltages, but at an angle of  $30^\circ$  from the primary voltage.

In Fig. 203, the secondary phase voltages are  $180^\circ$  in phase relation from those in the primary. Therefore, the delta voltage between the secondary leads of the transformer and between the secondary

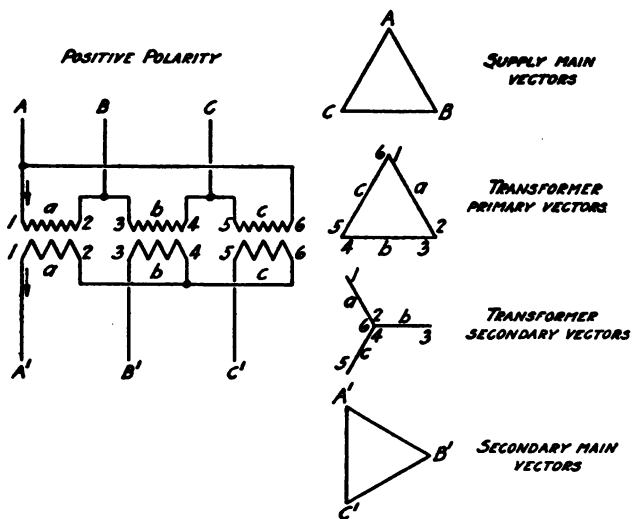

Fig. 199.—Transformers connected "Δ" primary and "Y" secondary.

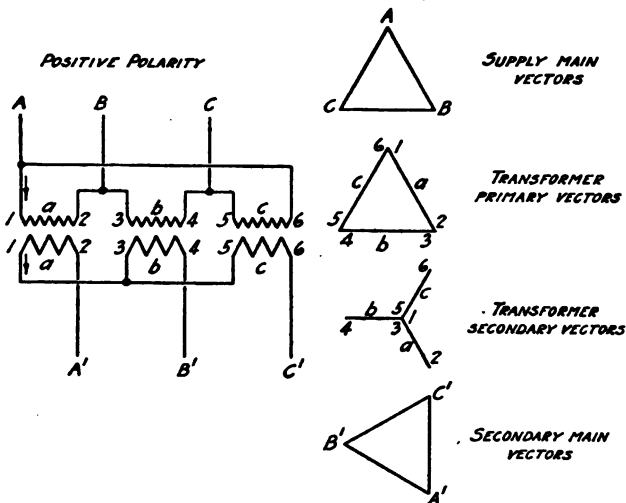

Fig. 200.—Transformers connected "Δ" primary and "Y" secondary.

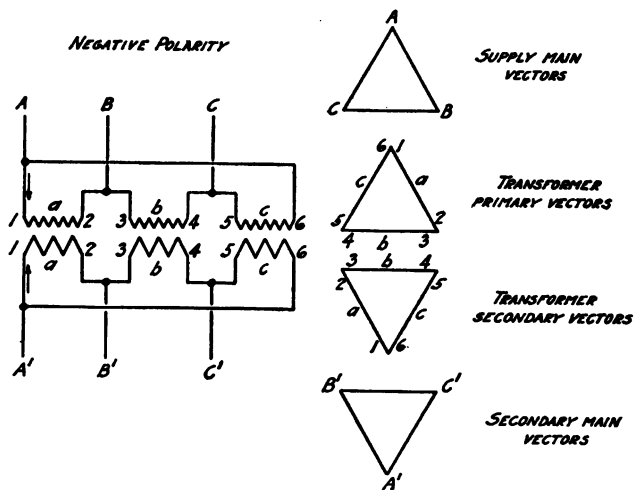

FIG. 201.—Transformers connected "Δ" primary and "Δ" secondary.

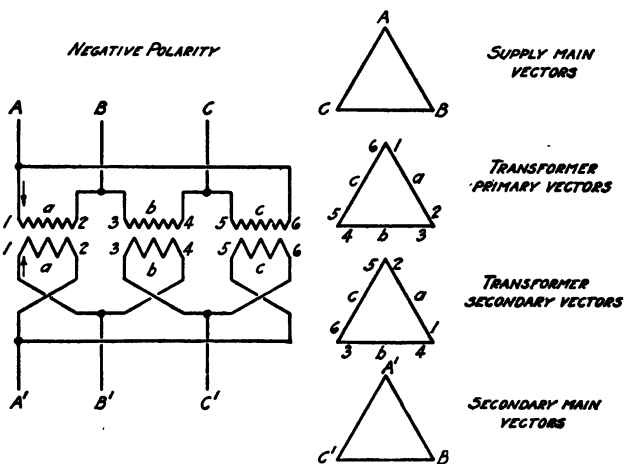

FIG. 202.—Transformers connected "Δ" primary and "Δ" secondary.

# TRANSFORMERS

Sec. 6

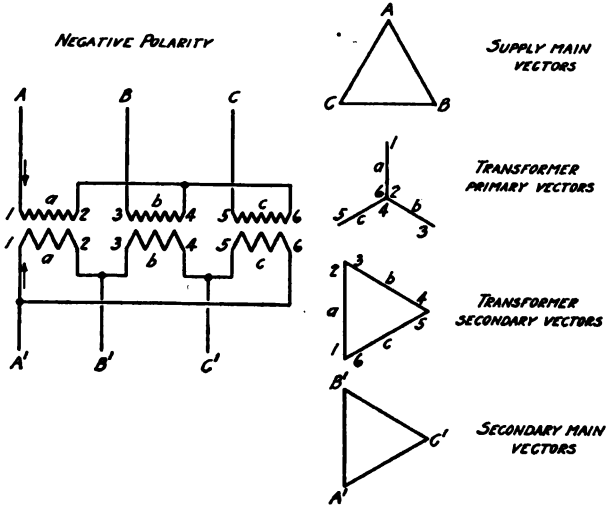

FIG. 203.—Transformers connected "Y" primary and "Δ" secondary.

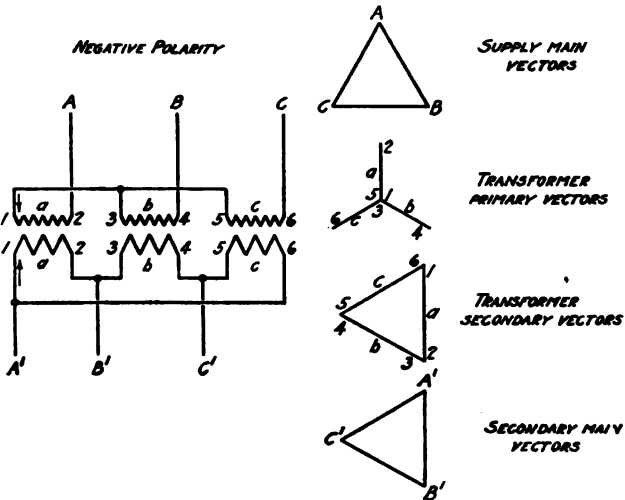

FIG. 204.—Transformers connected "Y" primary and "Δ" secondary.

mains is the reverse of that in Fig. 198. By reversing the primary leads as illustrated in Fig. 204, the voltage impressed upon the primary and, in consequence, the voltage induced in the secondary is reversed. Therefore, even though the transformers have opposite polarity they may be connected in parallel.

Transformers of opposite polarity, connected  $\Delta$  primary and Y secondary are shown in Figs. 199 and 205. Such transformers cannot be connected in parallel. However, by reversing the connections as shown in Fig. 200, they may be connected in parallel.

Transformers as illustrated will parallel as follows: Fig. 197 with 202, 198 with 204, 199 with 206, 200 with 205 with symmetrical connections.

Transformers as illustrated in Figs. 198 and 204 may be connected to those illustrated in Figs. 200 and 205 provided A' Fig. 198 is connected with C' Fig. 200; B' Fig. 198 with A' Fig. 200; C' Fig. 198 with B' Fig. 200.

Transformers as illustrated in Figs. 199 and 206 may be connected in parallel to transformers as illustrated in Fig. 203, provided A', Fig. 199, is connected to B' Fig. 203; B' Fig. 199 to C' Fig. 203; C' Fig. 199 to A' Fig. 203.

Transformers as illustrated in Fig. 201 cannot be connected in parallel with any of the other transformer connections illustrated.

In order that transformers should operate successfully when connected in parallel or when connected to a three-phase source of supply it is necessary that a proper phase relation be maintained and also that the transformers thus connected shall have the same reactance and resistance. This is strictly true. Within commercial limits, however, the division of load is correct if the voltage ratio and the impedance are the same, even though the resistance components may differ. If this condition is not maintained, the transformers will not share the load equally and the three-phase secondary voltages will be distorted.

The method of connecting two transformers to a three-phase four-wire system, as illustrated in Fig. 207, provides a balanced three-phase secondary supply, but produces an unbalanced condition on the primary system for which reason it is seldom used.

Fig. 208 illustrates the incorrect method of connecting transformers as above described. This method produces a distorted secondary voltage as well as unbalancing the primary system.

The method of transforming three to two phase is illustrated in Figs. 209 and 210. Lead 1 of transformer a is connected to the supply main, A; lead 2 (it should be noted that this lead 2 is not the end of the winding, but is a tap at the 86.6% point) of the transformer a is connected to the junction of coils b and c of the second transformer. Transformer lead 3 is connected to the supply B. Transformer lead 4 is connected to the supply main C. The voltages impressed on the transformer windings are illustrated vectorially in Fig. 209. As the polarity has been assumed to be positive, the secondary vectors bear the same phase relations as those in the pri-

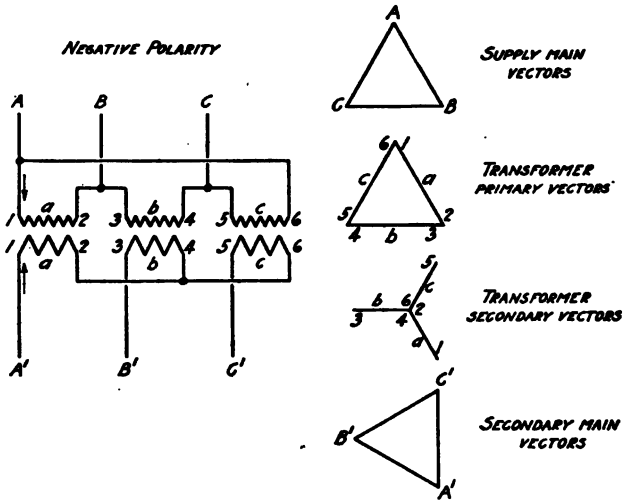

FIG. 205.—Transformers connected "Δ" primary and "Y" secondary.

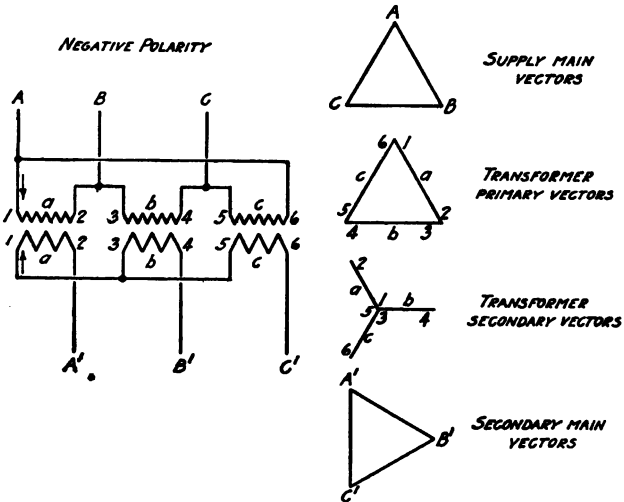

FIG. 206.—Transformers connected "Δ" primary and "Y" secondary.



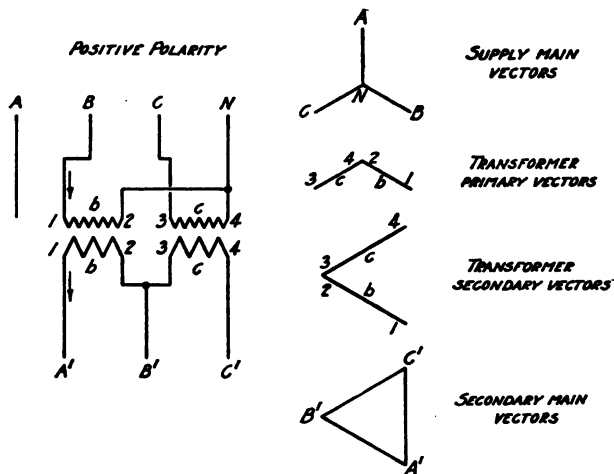

FIG. 207.—Correct method of connecting two transformers between the phase wires and the neutral wire of a three-phase system.

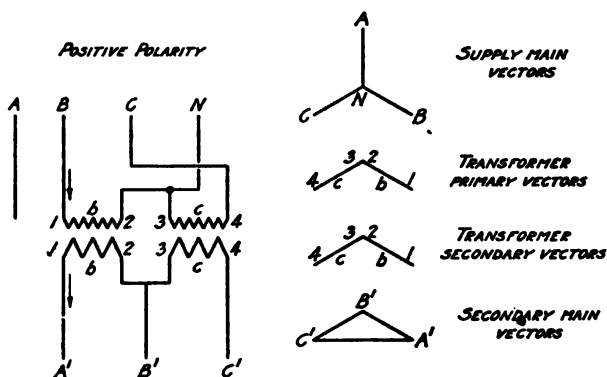

FIG. 208.—Incorrect method of connecting two transformers between the phase wires and the neutral wire of a three-phase system.

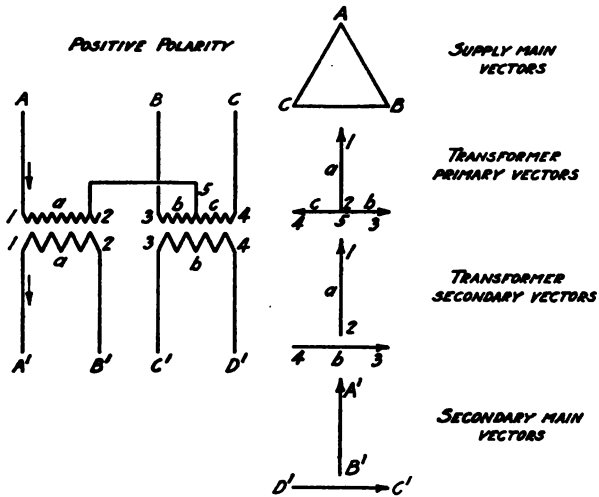

FIG. 209.—Transformer connections for transforming from three- to two-phase.

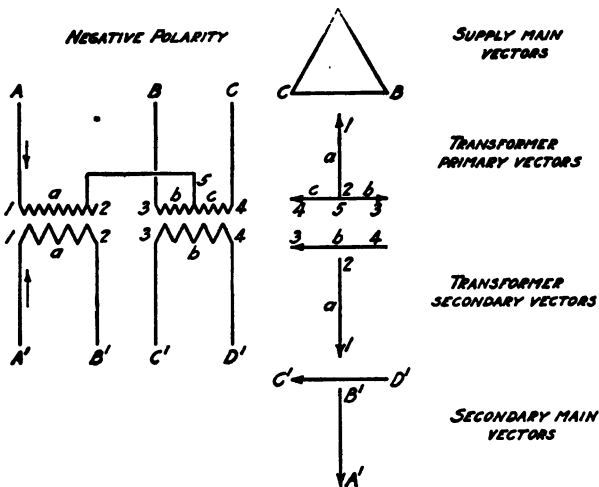

FIG. 210.—Transformer connections for transforming from three- to two-phase.

mary and, in consequence, the voltages between A' and B', and C' and D' will be the same as in the transformers a and b.

In Fig. 210 the secondary voltages are reversed, as the polarity of the transformers is negative instead of positive, and it is, therefore, impossible to parallel the transformers as illustrated in Figs. 209 and 210 on the secondary side. If, however, A' Fig. 209 is connected to B' Fig. 210; and B' Fig. 209 to A' Fig. 210; C' Fig. 209 is connected to D' Fig. 210, and D' Fig. 209 is connected to C' Fig. 210, and providing their characteristics are the same the transformers may be operated in parallel.

**37. SCOTT TRANSFORMATION VECTOR ANALYSIS** (Fig. 211). Illustrating the transformation from a three-phase system, in which the delta voltage is E to a two-phase system in which the phase voltage is E, draw an equilateral triangle A, B, C to a scale proportional to E, which represents the delta voltage of the three-phase system. Draw AO from the point A to the center of BC, which represents the voltage on the three-phase side of the transformer in

Fig. 209 and is equal to the  $\frac{\sqrt{3}}{2} \times E$ ;  $OB = \frac{E}{2}$  and  $OC = \frac{E}{2}$  representing respectively the voltages impressed on the windings b and c of the transformer illustrated in Fig. 209.

Draw OD equal to CB. This represents E the voltage of one phase of the two-phase system. Draw OF equal to BC. This represents the voltage of the other phase of the two-phase system.

The ratio of OF to OA is equal to  $\frac{2}{\sqrt{3}}$ . Draw Oa at an angle  $\theta$  from

OA representing the power factor on the three-phase side of the transformer. The length of Oa is proportional to the load current I on the three-phase side of the transformer. Draw Oc and Od proportional to I, each  $120^\circ$  from Oa. These represent the currents flowing in each half of the transformer connected to BC. Since the ratio of OF to OA is  $\frac{2}{\sqrt{3}}$  the current flowing in the two-phase side of the trans-

former must be equal to  $I \times \frac{\sqrt{3}}{2}$ . Lay off Ob equal to this value, Ob

then represents in value and phase the current in the two-phase winding of the transformer. Connect d and c, then drop a perpendicular line from O to dc bisecting this line at e. Draw Of parallel to dc and equal to ec. This represents both in value and in phase the current in the other two-phase winding of the transformer,

and is equal to  $I \times \frac{\sqrt{3}}{2}$ , one-half dc is used, as the difference in these two currents is in effect only flowing through one-half of the coils on the three-phase side of the transformer.

**38. THE SPECIAL SERIES INCANDESCENT LIGHTING TRANSFORMER** (Fig. 212) is a constant potential transformer

constructed with a number of primary taps, by the use of which it may be connected to primary circuits with various percentage drops. Numerous leads are also brought out from the secondary winding to permit its connection to series circuits, in which the numbers of lamps may vary. Each lamp is supplied with a small inductance in parallel with the lamp filament. The resistance of the lamp filament and this inductance are so proportioned that when the filament is intact the major part of the line current flows through the filament. If, however, the filament is broken the current will flow through the inductance and the circuit will remain closed.

In Fig. 212 the current is shown flowing through one of the inductances at a location where the filament of the lamp has been

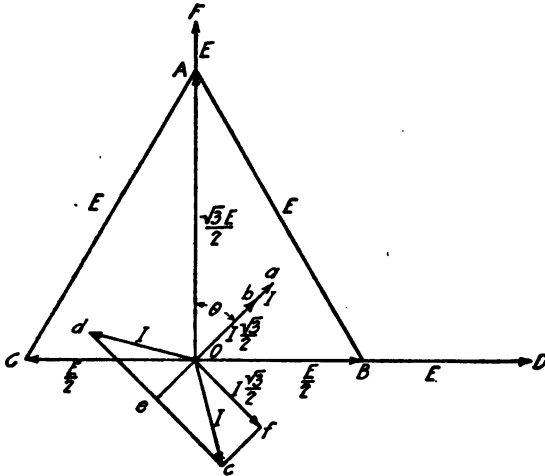

FIG. 211.—Vector analysis of three-phase, two-phase transformation.

broken. Under such conditions the voltage across each lamp and the current flowing in the circuit are practically the same as when all the lamps are burning.

The power-factor of the transformer will vary with the number of lamps burning, i. e. the power-factor will be lower when the percentage of lamps burning is small than when all are burning.

A typical regulation curve is given in Fig. 213.

Such transformers may be tested in a manner similar to the method used when testing commercial power and lighting transformers.

## INDUCTION REGULATORS

**39. General Description.** The induction regulator is a special type of transformer built like an induction motor with a coil-wound

secondary, which is used for varying the voltage delivered to a synchronous converter or alternating-current feeder system. In comparison with a variable ratio transformer it possesses the advantage of being operated without opening the circuit and without short-circuiting any transformer coil. However, it has a larger magnetic leakage and a higher value of exciting current than a transformer of equal capacity. The primary of the induction regulator is subjected to the constant voltage of the supply system. The delivered voltage being varied by combining with the supply voltage the e. m. f. generated inductively in the secondary. The primary is normally at rest, although it is movable at will for the purpose of varying the voltage.

There are two distinct types of induction regulators, possessing different inherent characteristics but performing similar duties, namely, the single phase and the polyphase. The former is used for single-phase lighting circuits while the latter is generally employed in connection with rotary converters and similar apparatus.

In the single-phase induction regulator the voltage generated

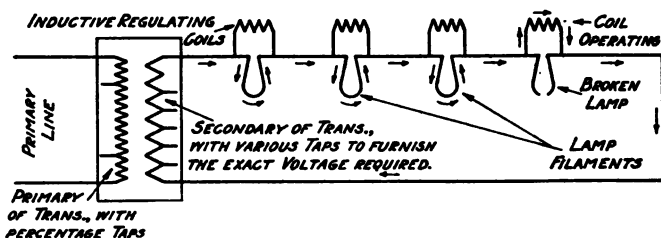

FIG. 212.—Special series incandescent lighting transformer.

in the secondary varies with the mechanical position of the rotor, but the voltage at all times remains directly in time phase with (or time phase opposition to) the primary e. m. f. Thus the resultant delivered e. m. f. is equal to the arithmetical sum (or difference) of the primary and the secondary e. m. f.—the latter depending upon the position of the movable element.

Referring now to the diagrams of Figs. 214 and 215, showing the values of the primary and secondary electromotive forces, let  $OA$  be the value and time phase position of the e. m. f. of the primary coil, and let  $OD$  or  $OE$  be the maximum value of the e. m. f. of the secondary; this e. m. f. may be either subtracted from or added to the primary e. m. f. (according to the mechanical position of the moving member) in order to produce the resultant e. m. f. If now the line  $OE$  be allowed to represent also the mechanical position (in electrical space degrees) of the moving member when the maximum secondary e. m. f. is additive in phase with the primary e. m. f., then  $OD$  (180 electrical space degrees from  $OE$ ) is the mechanical position of the

moving member when the **maximum e. m. f. is subtractive** in phase with the primary e. m. f. When the mechanical position of the moving member is **OB** (Fig. 214) the secondary e. m. f. may be considered to have the value **OC** (**CB** being perpendicular to **OD**), but it remains in time phase (opposition) with **OA**, so that the resultant delivered e. m. f. is **CA**, similarly when the mechanical position of the moving member is **OB'** (Fig. 215) the secondary e. m. f. is **OC'**

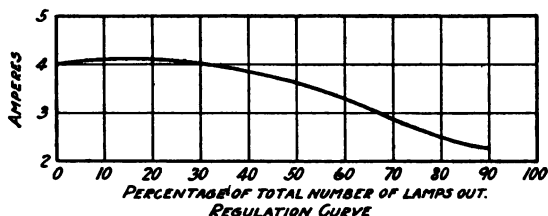

FIG. 213.—Typical regulation curve of the special series incandescent lighting transformer.

and it is in time phase with **OA**, so that the resultant delivered e. m. f. is **C'A**.

The current which exists in the secondary of the single-phase induction regulator is the delivered line current, which depends inversely upon the impedance of the delivery circuit and directly on the delivered e. m. f. The load current in the primary has a value such that its magneto-motive-force counter-balances the

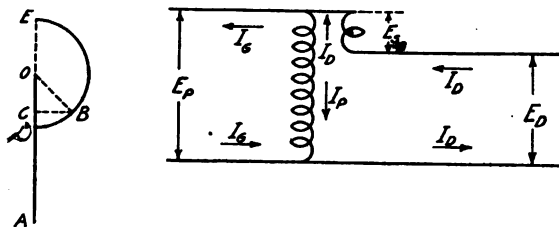

FIG. 214.—E. M. F. circuit and current diagram of a single-phase induction regulator in a negative boost position.

demagnetizing (or magnetizing) effect of the secondary current on the magnetic core. The load current supplied to the regulator circuit is the arithmetical sum of the primary and secondary currents when the secondary e. m. f. is added to the primary e. m. f. while it is the arithmetical difference between these two currents when the resultant delivered e. m. f. is the difference between the primary e. m. f. and the secondary e. m. f.

It is interesting to note what occurs when the moving member occupies a mechanical position 90 electrical space degrees from the position indicated by OD or OE in Figs. 214 and 215. In this position the value of the secondary e. m. f. is zero, because the flux due to the primary exciting current passes through the secondary core parallel to the secondary windings. The resultant delivered e. m. f. is therefore equal to the primary e. m. f. When the regulator is in use, even when the secondary e. m. f. is of zero value, the secondary current may have the full load value because it depends solely upon the delivered e. m. f. and the impedance of the delivery circuit. With the moving member in the position here assumed, the magnetomotive-force of the secondary current would be opposed in no respect by any primary current so that a large value of flux would tend to interlink with the secondary coil and produce an enormous reactance therein. To overcome this defect there is placed upon the primary core, in electrical space quadrature with the primary coil, a separately insulated coil which is electrically closed upon itself and forms a

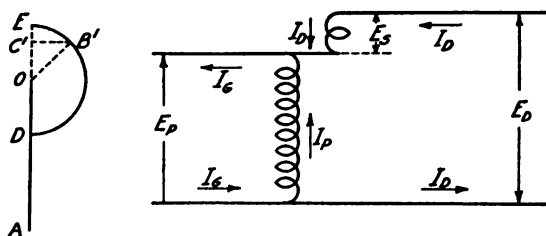

FIG. 215.—E. M. F. circuit and current diagram of a single-phase induction regulator in a positive boost position.

short circuited secondary to the real secondary coil of the regulator which acts as its primary coil. This coil may be referred to as the tertiary coil of the regulator. The primary and the tertiary coils are usually placed on the movable, and the secondary on the stationary member, when the movable member of the regulator is in the maximum, positive boost position or the maximum negative boost position (Figs. 214 and 215) the secondary m. m. f. is directly opposed by the primary m. m. f. and no current is produced in the tertiary coil. At intermediate positions the secondary m. m. f. is opposed in part by the m. m. f. of current in the primary coil and partly by m. m. f. of current in the tertiary coil; the resultant of these two m. m. f.'s. being just equal to the secondary m. m. f. so that the reactance of the secondary is reduced to that due to the magnetic leakage between the stationary and the movable members.

The polyphase induction regulator in every essential detail is a polyphase induction motor whose polyphase coil-wound rotor can be locked in any position desired. The primary windings are connected across the supply lines just as are the primary windings of a

polyphase induction motor; however, instead of being closed upon themselves as is true of the secondary windings of an induction motor, the secondary windings of the phases of the induction regulator are separately insulated and separately connected in series in the delivery circuits from the regulator. When polyphase e. m. f.'s are impressed upon the primary windings, the e. m. f. generated in each secondary coil is of the same frequency as the primary e. m. f. Its value is constant and entirely independent of the mechanical position of the movable member; the time-phase position of these e. m. f.'s., however, varies directly with the electrical space position of the movable member. This resultant delivered e. m. f. is the vector sum of (or difference between) the primary and the secondary e. m. f.'s.: it is not constant in value but varies largely with the position of the movable member.

Referring to Fig. 216, let  $OA$  represent the e. m. f. of a certain primary phase both in value and time-phase position, let  $OE$  (or  $OD$ ) represent the e. m. f. of the corresponding secondary phase winding in the maximum positive (or maximum negative) boost position. Let  $OE$  (or  $OD$ ) simultaneously represent the mechanical position (in electrical space degrees) of the moving member when the secondary e. m. f. is in time-phase with (or time-phase opposition to) the primary e. m. f. In any mechanical position of the moving member, such as  $OB$ , the secondary e. m. f. has a value equal to  $OE$  (or  $OD$ ) and its time-phase position is correctly represented by the line  $OB$ . This fact is attributable to the existence of a revolving field produced by the combination of the fluxes of the separate primary phases. For the present discussion the revolving field may be considered to have a constant strength, so that the time-phase position of the e. m. f. produced in any conductor subjected to this field will vary directly with its relative electrical space position. Since in Fig. 216 the primary e. m. f. is  $OA$  and the secondary e. m. f. is  $OB$  the resultant e. m. f. must be  $AB$ , both in value and in relative time phase position.

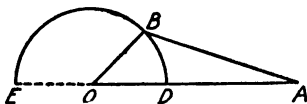

FIG. 216.—Vector diagram of a polyphase induction regulator.

The current in the delivery circuit (which is the same as that in the secondary coil) depends directly upon the resultant delivered e. m. f. and the impedance of the delivery circuit. In the polyphase induction regulator, there is no special tertiary circuit, but each primary phase winding acts in part as the tertiary circuit for the remaining primary phase windings and the several secondary phase windings. Thus the m. m. f. of the current in any secondary phase winding in any position whatsoever is fully counterbalanced (except for magnetic leakage) by the m. m. f. of the current, or currents, of



one or more primary phase windings, and the reactance of the secondary is reduced to that due to the magnetic leakage between the stationary and movable members.

**40. The Pole Type Induction Regulator** has been developed in order that long lightly loaded branch feeders may be connected to heavily loaded main feeders. Unless an intermediate voltage control is installed, regulation on such a branch is very poor, especially when connected to a main feeder close to the station.

The general construction of the regulator is illustrated in Figs. 217 and 218.

The usual regulator construction is departed from, due to the small amount of space available. See Fig. 219. The stator or



FIG. 217.—Pole type induction regulator showing cast lugs for hanging on transformer hooks.

secondary core has two slots only, in which a form wound coil is placed. The rotor or primary core has four slots, two of which are occupied by a single primary coil, wound directly on the core. The remaining slots, which are in quadrature with the slots containing the primary winding, are opposite the secondary coil in Fig. 219. These slots contain round copper rods riveted to the cast brass flanges located at the top and bottom of the rotor, thus clamping the primary punchings and also acting as a tertiary coil. The flanges attached to these brass castings hold the rotor in alignment.

Diagrammatic connections are illustrated in Fig. 220. The rotor is operated by a continuously running single-phase motor, by

means of a ratchet and pawls. A voltage relay controls the pawls, so that, to raise the voltage the ratchet wheel is revolved in a given direction and to lower the voltage in an opposite direction. The relay is designed so that there are no arcing contacts.

Such regulators are built in 10, 15, 25, and 50 ampere sizes, for 60 cycle circuits up to and including 2300 volts. The range of regulation is 10% above or below normal. The motor and relay are designed to operate on 110 or 220 volts.



FIG. 218.—View of mechanism and core of pole type induction regulator.

#### 41. INDUCTION REGULATOR TESTS may be divided as follows:

1. The **Insulation Test** is made in a manner similar to such tests for transformers (Figs. 174 and 175), except that the secondary or stator coils should be tested at the same voltage as that of the primary or rotor winding, the condition under which they normally operate (Art. 23).

2. The **Heating Test** can be simplified as it is not necessary to have an external source of current supply to circulate the loading current. Full load conditions may be obtained when testing two regulators of the same general characteristics (Fig. 181) by setting

## Sec. 6

## REGULATORS

the rotating elements at such positions as to cause full load current to flow.

If only one regulator is to be tested the rotating element may be set so that full load current will flow in the short-circuited secondary when normal voltage is impressed upon the primary. As full load

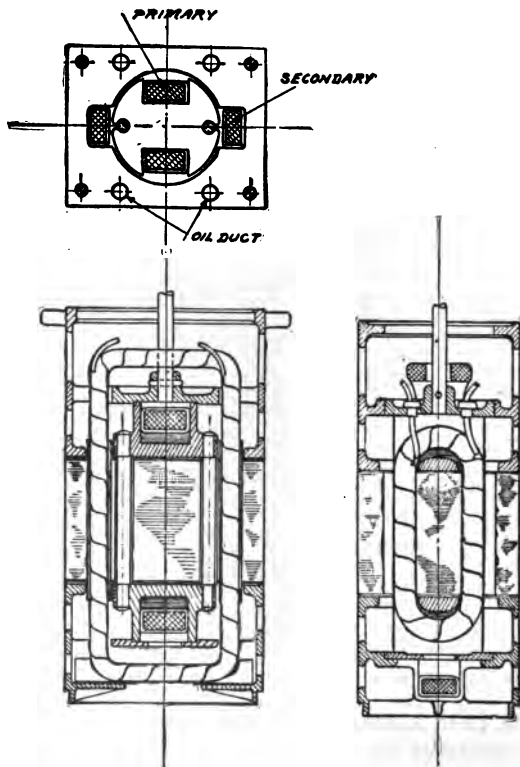

FIG. 219.—Section of regulator winding and core.

conditions are not obtained in the primary, this is an approximate test.

3. Iron Loss Test (Art. 25).

4. Resistance Tests (Art. 26).

5. Copper Loss Tests and Impedance Tests are made in a manner

similar to that for transformers (Art. 27), except that they should be made at several positions in the mechanical rotation of the primary or rotor.

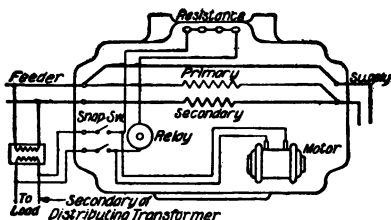

FIG. 220.—Connection diagram of pole type regulator.

6. **The Range of Regulation** may be determined by connecting a voltmeter to the secondary winding and rotating the primary, operated at normal voltage, through an arc large enough to obtain readings from zero to a maximum value as indicated on the voltmeter. The values thus obtained corrected for the impedance drop at full load represent one-half the total range of the regulator.

Let

$E_s$  = the maximum effective value of the regulator secondary voltage.

$e$  = the percent variation in voltage from no load to full load referred to full load voltage, for maximum boost position. (This is found in the same manner as for transformers. Art. 49, Section 7.)

Then the range of the regulator is

$$\text{Range in volts} = 2 E_s \left(1 - \frac{e}{100}\right)$$

### BIBLIOGRAPHY

- A. I. E. E., July, 1909, Mr. L. W. Chubb.
- “ 1910, Mr. H. W. Tobey.
- Publications of Various Manufacturers.
- Pennsylvania Electric Association, 1912, Mr. F. W. Shackelford.
- Alternating current, Franklin & Williamson.
- Foster's Electrical Engineers' Pocket Book.
- Standard Handbook for Electrical Engineers.
- American Electricians' Handbook.

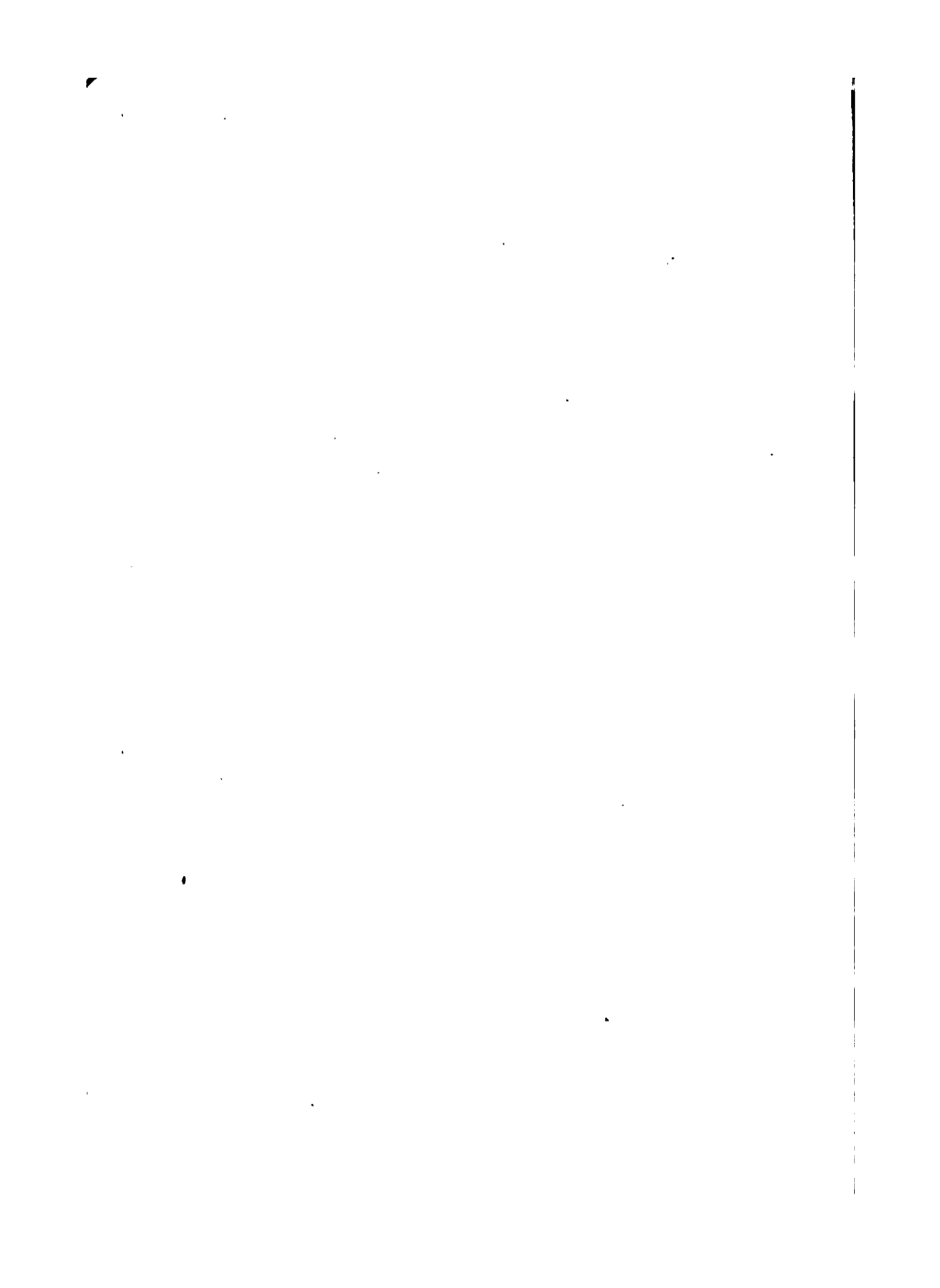

# **SECTION 6**

---

## **PART II**

### **LIGHTNING PHENOMENA IN CONNECTION WITH ELECTRIC CIRCUITS, PROTECTIVE APPARATUS, GROUNDING**

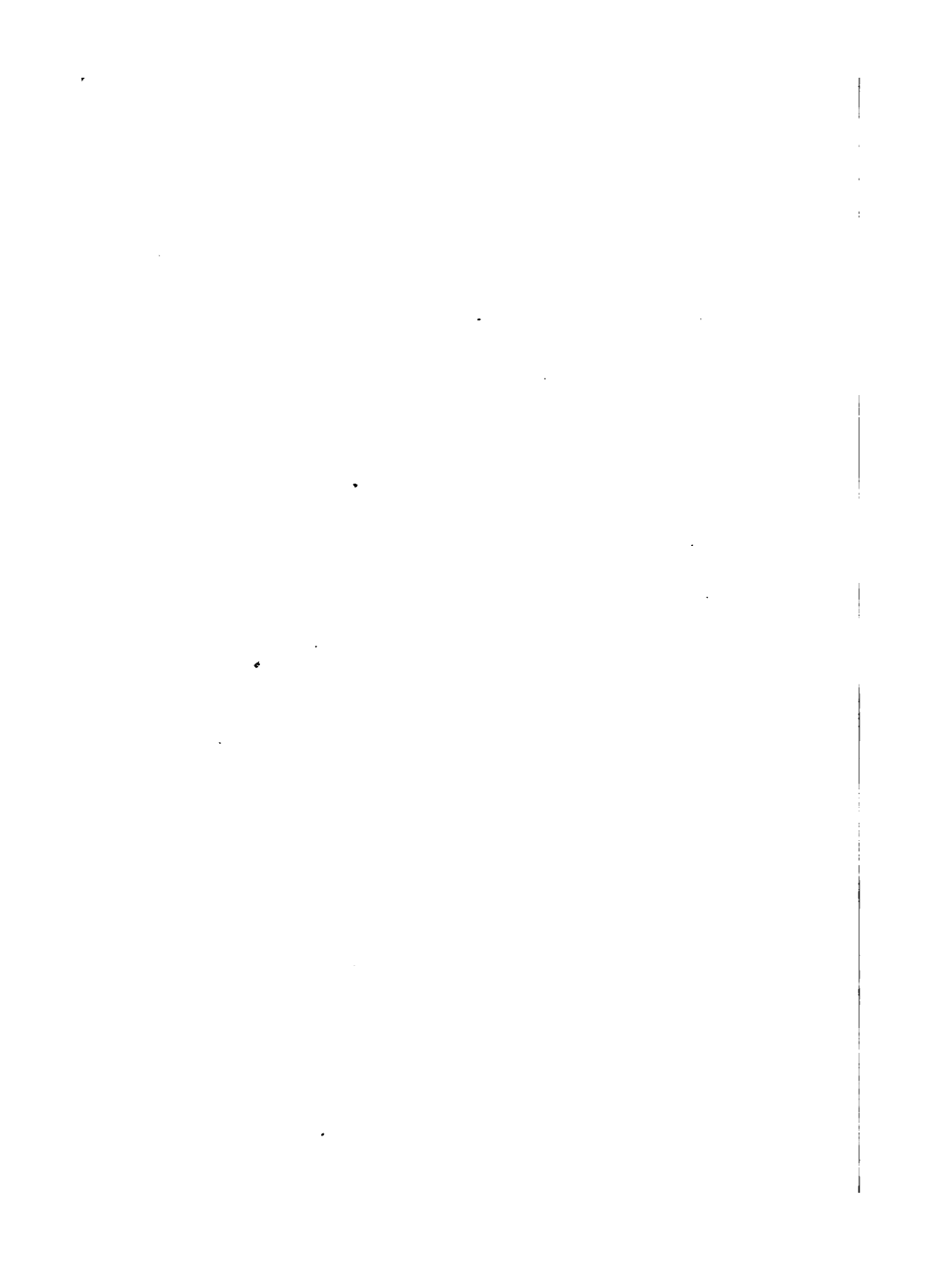

## SECTION 6

### PART II—LIGHTNING PHENOMENA IN CONNECTION WITH ELECTRIC CIRCUITS, PROTECTIVE APPARATUS, GROUNDING

#### TABLE OF CONTENTS

	ARTICLE
<b>Lightning Phenomena in Connection with Electric Circuits.</b>	
General . . . . .	1
The Electric Charge . . . . .	2
An Impulse or Traveling Wave . . . . .	3
Standing Waves . . . . .	4
High Currents . . . . .	5
<b>Protective Apparatus</b>	
General . . . . .	6
Multigap or Low Equivalent Arresters . . . . .	7
Compression Type Arresters . . . . .	8
Circuit Breaker Type Arresters . . . . .	9
Aluminum Cell or Electrolytic Arresters . . . . .	10
Single Gap and Multipath Arresters . . . . .	11
Location of Lightning Arresters . . . . .	12
Installation of Lightning Arresters . . . . .	13
Horn Arresters . . . . .	14
Choke Coils . . . . .	15
Ground Wires . . . . .	16
Switches . . . . .	17
Fuses . . . . .	18
The Link Fuse . . . . .	19
The Enclosed Cartridge Fuse . . . . .	20
The Expulsion Fuse . . . . .	21
<b>Grounding</b>	
General . . . . .	22
Laws of the Resistance of Pipe Earth Connections . . . . .	23
Making the Earth Connections . . . . .	24
Testing Grounds . . . . .	25



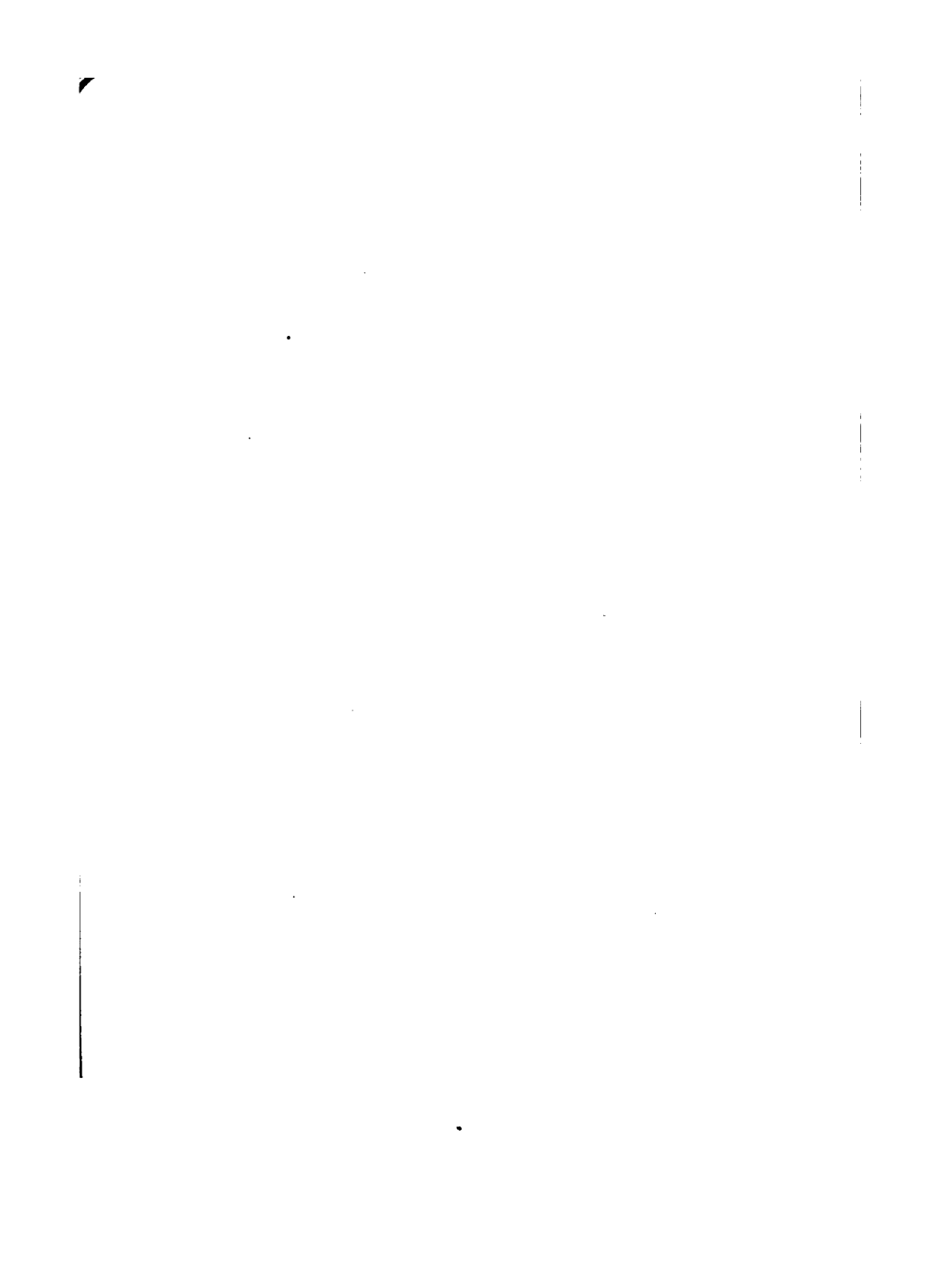

## LIGHTNING PHENOMENA IN CONNECTION WITH ELECTRIC CIRCUITS

1. **General.** The phenomena causing trouble in electric systems may be divided into three general classes.

- 1st. High voltage. (Art. 2-4.)
- 2nd. High frequency. (Art. 2-4.)
- 3rd. High current. (Art. 5.)

In any system of energy transmission there are three types of phenomena causing strains; namely, steady stresses, impulses or blows, and vibrations.

In an electric system high frequency and high voltage cause the same types of stresses; namely,

- (a) Steady stress or gradual electric charge. (Art. 2.)
- (b) Impulse or traveling wave. (Art. 3.)
- (c) Standing wave or oscillation and surge. (Art. 4.)

2. **The Electric Charge.** The total potential difference between the ground and an electric circuit, may gradually rise by the accumulation of an electric charge in the circuit, until the lightning arresters discharge or the insulation is punctured, depending upon which is the point of least resistance.

Some of the factors causing such a steady and gradual accumulation of electric charge are:

- (a) The collection of static charge from rain, from snow drift, or from fog, carried by wind across the line. The presence of accumulated static may be indicated by a series of periodic lightning arrester discharges.
- (b) An accumulated static charge may follow the passing of charged clouds due to electrostatic induction. Assuming for instance, a charged cloud passing over a transmission line. The ground below the line carries an electrostatic charge of opposite sign, corresponding to the charge of the cloud. The line should have a charge also, higher than that of the ground since projecting above it. If the line is insulated from ground, without the charge required for electrostatic equilibrium, it thus appears at a potential against ground; that is, at cloud potential. With the approach of a charged cloud to the transmission line, the potential of the line against ground rises until a discharge takes place between the ground and line, charging the line to ground potential. Inversely, with the cloud receding from the line, the line charge is not bound by the charge of the cloud and therefore discharges to ground.
- (c) Potential differences between the line and ground due to differences of atmosphere potential in different regions traversed by the line, especially so if the line passes through different altitudes.

- (d) Accidental electrostatic charges entering the circuit as from frictional electricity from belt-driven machinery.
- (e) Unsymmetrical conditions of the generator potential such as the grounding of a wire on a three-phase system which will give the system, as a whole, an alternating potential difference to ground, equal to the voltage between a phase wire and the neutral of the system.
- (f) The existence of higher harmonics in the electro-motive-force wave of a polyphase system may cause trouble if they are of such an order that they coincide in the different phases; that is, the whole system rises and falls with their frequency. In a three-phase system, the third, ninth, fifteenth, etc., harmonics coincide.

The effects of steady electrostatic stress, where uni-directional, and caused by external agents as items a to d or alternating and caused by internal agents, as items e and f, appear not only in the circuits in which they originate, but in circuits electrostatically connected to them.

The danger of such accumulations of potential lies in their liability to damage the insulation of the system by puncture or by their discharge, producing other and more serious disturbances.

**3. An impulse or traveling wave** is caused by sudden local electrostatic charges on a transmission line, such as a lightning stroke, induced potential caused by the sudden discharge of a cloud, or any other sudden local change in conditions. This wave of potential and current travels along the line just as a water wave travels over the surface of the ocean.

The wave front is very steep, i. e., has high voltage at the point of impact, but gradually flattens out, and if the line is of unlimited length ultimately disappears.

If the line is of definite length the wave is reflected and combines with the incoming waves to form a system of nodes and maxima, called standing waves.

When apparatus is connected to the line, the traveling wave divides, part is transmitted and part is reflected. The impulse is thus broken up into a number of secondary impulses and local standing waves, which may reach much higher voltages than that of the traveling wave.

Impulses or traveling waves may be caused by:

- (a) Direct or secondary lightning strokes, which generally do local damage, but do not travel far, as the disturbance is generally confined to a very few impulses of steep wave front but of short extent.
- (b) Electrostatic induction from lightning discharges. While each of these impulses is rarely of sufficient power to do serious damage, due to their frequency of recurrence, they may lead to the production of destructive internal surges. Impulses originating thus are felt more generally through

the system, but do not cause as much local damage as those originating from direct strokes.

- (c) The discharge of slowly accumulated potential resulting in a series of successive impulses.
- (d) Any spark discharge from line to line or from the line to ground.
- (e) Arcing grounds.
- (f) Sudden changes of load, switching, etc.

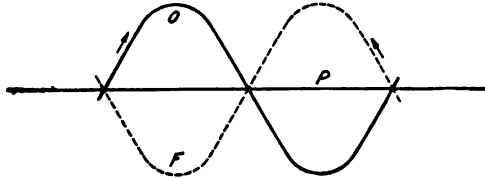

FIG. 221.

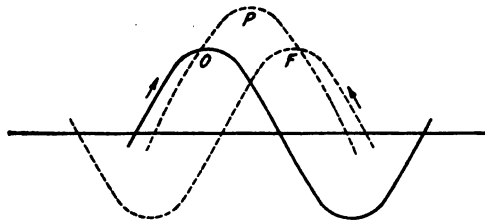

FIG. 222.

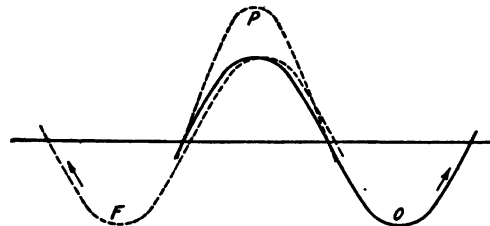

FIG. 223.

Impulses may be caused by external or internal disturbances. Items a and b may be classed as external causes, c and d as both external and internal causes, e and f as internal causes.

4. Standing waves are formed when a wave train is reflected, as the waves neutralize at some points forming a node and add at other

## Sec. 6

## PROTECTIVE APPARATUS

points forming a **wave crest**, of greater or less amplitude than that of the original wave, depending upon the phase relations of the original and reflected waves. Fig. 221, shows these waves in phase opposition; Fig. 222, about 90 degrees apart in phase, and Fig. 223 practically in phase. In each figure **O** is the original wave, **F** the reflected wave and **P** the resultant wave.

An oscillation is the phenomenon by which the flow of power in an electric circuit restores its equilibrium after a disturbance of the circuit conditions. Any circuit disturbance may, and usually does, produce an oscillation which may be local only, that is, contain only very high frequency harmonics, but it may become universal by including the fundamental and its lower harmonics. In the latter case it is usually called a **surge**.

Some of the typical forms of oscillation are:

- (a) Spark discharges to and from the line as over lightning arresters; the breaking up of a traveling wave entering the station, results in the formation of very high frequency oscillations, millions of cycles per second.
- (b) Arcing grounds and other arc discharges to ground from a line of an insulated system; reflected waves, etc., give oscillations which, while still of very high frequency, are considerably lower in frequency than item (a), that is, hundred thousand of cycles per second.
- (c) Charge and discharge, of the line as when discharging an accumulated electric charge over a path of low resistance; connecting a dead transformer to the line, etc., results in high frequency oscillations containing also an appreciable low frequency component.
- (d) Sudden changes in load, connecting or disconnecting a transmission line; opening a short circuit suddenly, etc., give oscillations in which the fundamental frequency predominates.
- (e) Low frequency surges, consisting primarily of the fundamental wave, may be produced by certain transformer connections. See Art. 17, Sec. 7.

The most powerful oscillation is the short circuit surge of a system, or oscillation produced by rupturing a short circuit as by a self-rupturing arc.

**5. High currents** cause damage in an electrical circuit due to the intense mechanical strains to which they subject the apparatus. The rapid interruption of high current phenomenon causes high voltage disturbances.

## PROTECTIVE APPARATUS

**6. General.** The principal protective apparatus for overhead lines may be divided into six general divisions as follows:

1. **Lightning Arresters.** (Arts. 7 to 11.)
2. **Horn Arresters.** (Art. 14.)

3. Choke Coils. (Art. 15.)
4. Ground Wires and Lightning Rods. (Art. 16.)
5. Insulator Protectors. (Art. 27, Sec. 5.)
6. Switches and Fuses. (Art. 17, 18-21.)

**Lightning Arresters.** The function of a lightning arrester is twofold; to discharge any high voltage disturbance that may occur on a line and to accomplish this while preventing the formation of a power arc which may cause greater voltages by oscillation, or which may interrupt service by forming a short circuit on the system.

- (a) Multigap or Low Equivalent Arresters. (Art. 7.)
- (b) Compression Type Arresters. (Art. 8.)
- (c) Circuit Breaker Type Arresters. (Art. 9.)
- (d) Aluminum Cell or Electrolytic Arresters. (Art. 10.)
- (e) Single gap and Multipath Arresters. (Art. 11.)

**7. MULTIGAP OR LOW EQUIVALENT ARRESTERS.** The general theory of this arrester is as follows: When voltage is applied across a series of multigap cylinders, the voltage distribution is not uniform. There is a capacity effect between the cylinders and from each cylinder to ground, which concentrates the voltage across the gaps nearest the line. When the voltage across the end gaps reaches a certain value, they arc across, passing the strain back to the other gaps, which in turn arc-over until the spark has passed entirely across the arrester. The arrester thus arcs over at a lower voltage than if the voltage were evenly distributed across the gaps.

When the arresters have arced over and current is flowing, the voltage is evenly distributed between the gaps and for this reason is too low to maintain an alternating current arc. The arc, therefore, lasts only to the end of the half cycle and then goes out. Alloys of metals with high and low boiling points are used for lightning arrester cylinder gaps. The metals with low boiling points tend to cool the arc while the metals with high boiling points tend to preserve the shape of the cylinder gaps.

In addition to the cooling effect of the cylinders, the temperature of the arc is affected by the amount of current flowing, which amount may be limited by the use of resistances.

If some of the gaps are shunted by a resistance high frequency disturbances will pass directly across the gaps, but the dynamic current will pass through the resistance and be limited. By using graded resistances connected to different gap cylinders the arrester may be designed to care for high frequency and low frequency disturbances equally well. This type of arrester is illustrated in Figs. 224 and 225.

This effect can be still further intensified with good results by bringing a connection at or near ground potential, near the series gaps, thus increasing the capacity current across the upper gap and lowering the breakdown voltage. An arrester embodying this feature is shown in Fig. 226. It consists essentially of a number of non-arcing metal cups, insulated from each other by porcelain spacers and connected in series with a resistance rod. Through the center of the metal cups passes a metal rod connected to the bottom cup but



FIG. 225.—Multigap lightning arrester, single pole, 3,000 volts, line to ground.



FIG. 224.—Low equivalent lightning arrester, single pole, 2,200 volts between phase wires.

thoroughly insulated from all others. The electrostatic effect of the close proximity of this rod to the upper cups causes the breakdown voltage of these gaps to be greatly lowered, and permits the use of more series gaps than would be possible were the control rod not present. The upper end of the rod is cemented into an insulator having a cap with a cast-in eye by which the arrester may be suspended. The lower end of the arrester carries a hook, to which another arrester can be attached when two in series are needed for high voltage lines. Good contact with the resistance rod is insured by a spring shunted by a flexible lead inside of the tube which encloses the resistance rod. This arrester may be used outdoors, and



FIG. 226.—Low equivalent lightning arrester, single pole.

for this service is equipped with a metal rain shield over the spark gaps.

**8. COMPRESSION TYPE ARRESTER.** The compression type arrester is a particular design of the Multigap arrester.

Fig. 227 illustrates the arrangement of the parts of the compression chamber arrester. On the outside, there is a porcelain base with four screw holes to connect it to a cross-arm. Immediately inside of this base are the antennæ. The antennæ vary in form in different arresters, but as illustrated they consist of two metal strips in the form of a "U" that fit inside of the holder or base. Inside of the antennæ is placed a straight porcelain tube. The porcelain tube is held in place by insulating cement. Inside of the porcelain tube the gap units are placed. Each gap unit consists of two punched metal hats of special alloy. The crowns of these hats are turned so they face each other, and both crowns are knurled. Between the rims of the two metal hats there is a short porcelain tube which holds the crowns of the metal hats about  $\frac{1}{32}$ " (0.9 mm.) apart. These gap



Sec. 6

PROTECTIVE APPARATUS

units are stacked one on top of the other inside the porcelain tube between the arms of the antennæ.

On top of the gap units is placed a resistance rod of low ohmic value. The gap units and resistance rods fill the long porcelain tube. On top of the resistance rod a spring contact is made, and a porcelain cap is fitted over the end of the tube and cemented thereto. The connecting wire projects through the porcelain cap. The ground connection is a wire which passes through the bottom of the base and is connected to the antennæ as well as to the lower gap unit. The arrester is hermetically sealed so that no dust, dirt or moisture can enter.

Due to the effect of the antennæ in this arrester, it is possible to

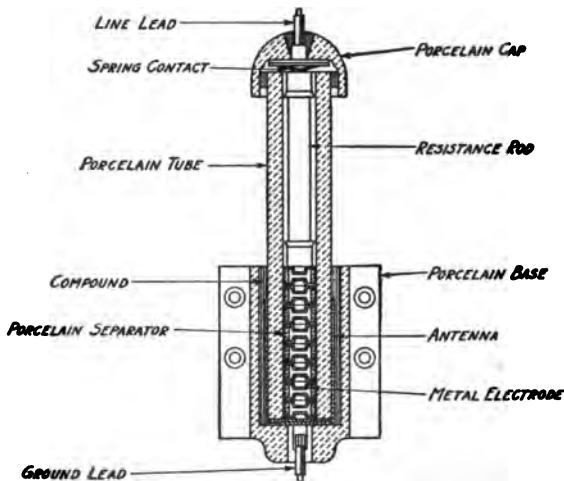

FIG. 227.—Compression type arrester.

use more than the usual number of gaps in series. In consequence the resistance in series with the gaps may be very low in value. The average value of this resistance is 23 ohms. The discharge current to ground per phase will be approximately equal to the lightning potential divided by 23 ohms.

The use of the antennæ gives uniformity in the spark potential regardless of the surroundings; its use also reduces the spark potential of the series of gaps used in this arrester, to exactly one-half the spark potential without the antennæ. This permits the use of twice as many gaps as would otherwise be possible. Each gap has the function of extinguishing a certain potential applied to it. There-

fore, when the number of gaps is doubled, the arc-extinguishing power of the arrester is greatly magnified.

Each gap is enclosed in a sealed chamber, and any expansion of gases in that chamber will cause an increase in pressure, which tends to extinguish an arc. Furthermore the porcelain tube which encloses the gap has its cooling surface in close proximity to the arc.

Another arrester operating on the compression principle is described as follows: This arrester is sometimes used for the protection of series D. C. arc circuits. It consists of two sets of metal electrodes mounted flush with the surface of a lignum vitae block. Charred or carbonized shallow grooves provide a ready path for the discharge, while a second block, fitting closely over the first block, confines the discharge and limits the formation of gases and vapors. Such gases as do form are highly compressed and are expelled violently through grooves transverse to the discharge path, thus rupturing the arc. As no series resistance is used with this arrester it has great freedom of discharge.

**9. CIRCUIT BREAKER TYPE ARRESTER.** This type of arrester is illustrated in Fig. 228 and consists essentially of the combination of small air gaps, low series resistance and a mechanical circuit breaker.

High frequency disturbances enter the arrester at line connection **A**, and pass to ground across gaps **B** and **C**, resistance rod **D**, and gaps **E** and **F**. Coil **H** and the mechanical circuit breaker are connected in multiple with the gaps **E** and **F**. This shunt path is of lower resistance than these gaps, but has a higher inductive or choking effect. The coil will therefore shunt any dynamic current following the discharge to ground from gaps **E** and **F**. High frequency disturbances, however, will not flow through this highly inductive shunt path, but will take the path across gaps **E** and **F**.

When the flow of dynamic current following the discharge to ground through the arrester is small, it is cut off by the action of the air gaps **B**, **C**, **E**, and **F** as the voltage wave crosses zero value. Under these conditions, the arc lasts only to the end of the half cycle and then dies out. These discharge electrodes are made of alloys of metals with high and low boiling points. The metals of low boiling points vaporize under the dynamic arc and tend to cool the gaps, while the metals of high boiling points tend to preserve the shapes of the discharge electrodes.

Whenever the flow of dynamic current to ground exceeds the values that will be cut off by the air gaps alone, this heavier flow is shunted from gaps **E** and **F** due to the low resistance of coil **H**; flows through the coil and so produces a magnetic field which raises the plunger **J**, thus cutting off the current inside the fiber tube and extinguishing the arc. The path of this dynamic current is indicated by the dashed lines.

These arresters may be used for higher voltages than that of each unit (Fig. 229) by connecting the units in series as shown in Fig. 230.

For pole work the arresters are mounted in wood boxes, and are usually supported from the arms by iron hangers.

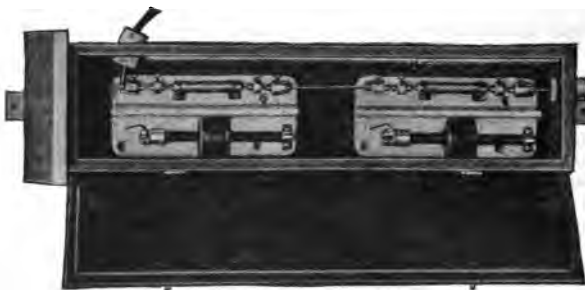

FIG. 230.—Circuit breaker lightning arrester, single pole, 6,800 volts.

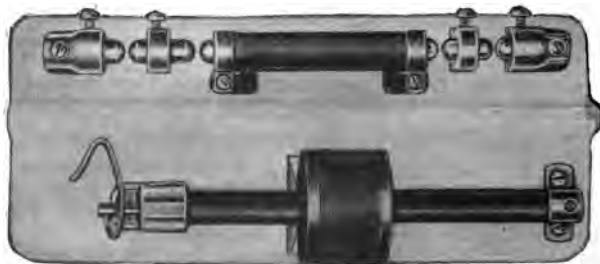

FIG. 229.—Circuit breaker lightning arrester, single pole, 3,300 volts.

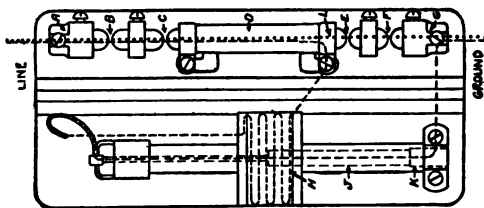

FIG. 228.—Diagrammatic view of circuit breaker lightning arrester.

### 10. ALUMINUM CELL OR ELECTROLYTIC ARRESTERS.

The aluminum cell arrester consists of plates of aluminum arranged as electrodes of a battery. The electrolyte may be anyone of a number of solutions. When current passes through an aluminum cell, an insulating film forms on the surface of the metal. This film has a certain dielectric strength. If the voltage rises above the critical value, current can flow through the cell with very little impedance.

When the line has been relieved of disturbances the voltage falls to the normal value (below the critical voltage of the arrester), and the film at once reforms and shuts off the current flow. If an alternating voltage with a maximum value above the critical voltage of the cell is impressed across an arrester, the peak of each voltage wave will be cut off by the arrester.

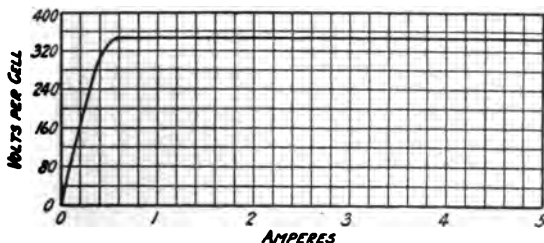

FIG. 231.—Characteristic curve of aluminum cell or electrolytic lightning arrester for alternating current.

The volt-ampere characteristic curve (Fig. 231) of the aluminum cell will vary somewhat according to whether direct or alternating currents are used.

A comparatively low voltage arrester is illustrated in Fig. 232, while in Fig. 233 is illustrated an arrester for high voltage lines. When an aluminum cell arrester is disconnected from the circuit for any great length of time, part of the film is dissolved and when reconnected to the circuit there is a momentary rush of current which reforms the film. The value of this current depends upon the length of time the arrester is disconnected from the circuit.

To prevent this film dissolution, it is advisable to charge the arrester once every twenty-four (24) hours, which may be accomplished by short-circuiting the gaps. Where it is deemed necessary resistance may be inserted to damp out oscillations resulting from charging, or to reduce the initial rush of current. Horn gaps with charging resistance are shown in Figs. 234, 235.

When the arrester cells are so assembled that one section is not connected directly to the line when charging, it is necessary to install a transfer or reversing switch connecting this section and one of the line sections so that the relative connections of the sections may be

reversed. The films on all the cells may thus be formed to the same critical voltage value.

**11. SINGLE GAP AND MULTIPATH ARRESTERS.** A type of low voltage arrester is shown in Fig. 236. This type consists of two heavily beaded brass discs, A and B, separated from each other at the beads by a  $\frac{3}{16}$  inch air gap by means of a high resistance disc C. Wires D and E are soldered to these discs, one of which is connected to the line wire, the other to the ground.



FIG. 232.—Three pole electrolytic lightning arrester for three-phase 6,600 volt circuits.

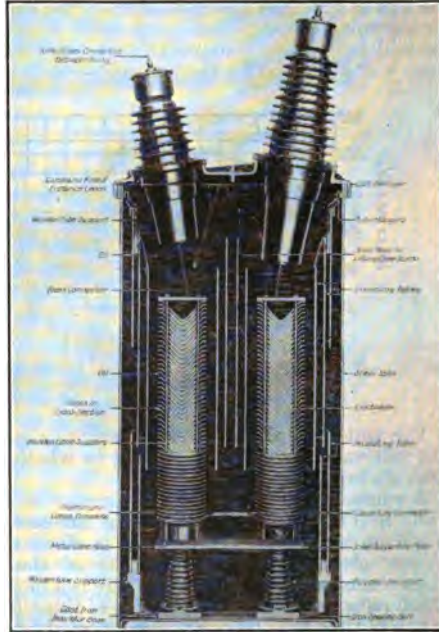

FIG. 233.—Single pole aluminum cell lightning arrester for 110,000 volt circuits.

Light charges of lightning and of accumulated static find a path from line to ground by leaking through this high resistance disc. When subjected to a heavier charge the high resistance disc prevents the charge leaking to ground quickly enough; hence, these heavier charges jump across the  $\frac{3}{16}$  inch air gap to ground.

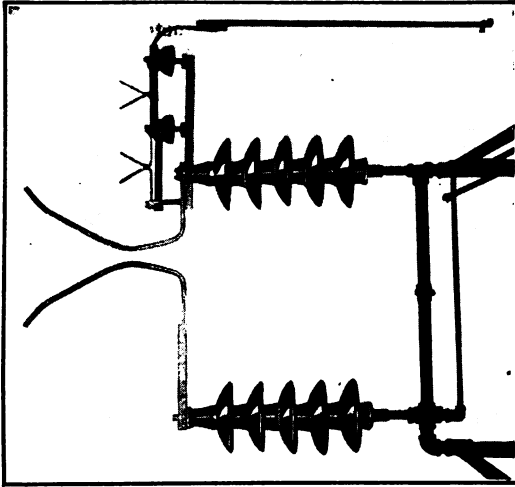

FIG. 235.—Horn gap with charging resistance for electrolytic lightning arrester, 110,000 volts.

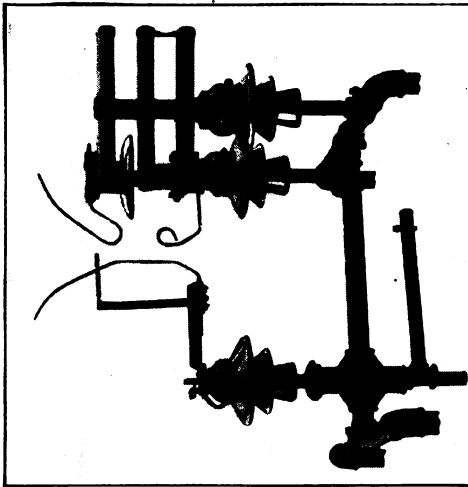

FIG. 234.—Horn gap with charging resistance for aluminum cell lightning arrester, 40,000 volts.

Sec. 6

PROTECTIVE APPARATUS

The flow of line current following the high potential discharge to ground is usually very small, and when the voltage of the circuit crosses zero value, the arc dies out. The metallic beads being large and cool, cool the arc vapors to such an extent that when the voltage

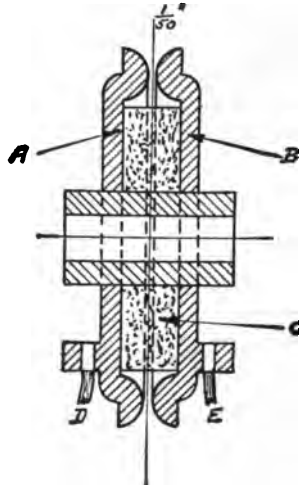

FIG. 236.—Diagrammatic view of single gap lightning arrester.

wave builds up to a maximum value, the voltage is not sufficient to again start an arc at the air gap.

The assembled arrester is illustrated in Fig. 237.



FIG. 237.—Single gap lightning arrester.

The multipath arrester (Fig. 238) consists of a carborundum block enclosed in a cast iron shell or box. A small spark gap of slightly over  $\frac{1}{4}$ th of an inch, mounted inside of the case in series with the carborundum block, serves to keep the latter normally

insulated from the line. The terminals to the circuit and the ground connection are attached to metal plates on either side of the block and all discharges must pass between them.

The static discharge spreads itself over the carborundum block along a number of minute discharge paths (multipath). The voltage across each gap is very low; therefore, the line voltage cannot maintain an arc across them. The action is analogous to that of a coherer in wireless telegraphy in that the body of the block becomes momentarily conducting as a result of the shock given the slightly separated particles. Thus, while the ohmic resistance to slowly applied low potentials is several megohms, the equivalent spark gap is very low. These arresters are single pole and may be mounted on a pole or used in the station, and are suitable for either alternating current or direct current circuits up to 1000 volts.



FIG. 238.—Multipath lightning arrester.

**12. LOCATION OF LIGHTNING ARRESTERS.** No general rule can be made governing the required number or the spacing of lightning arresters. Installations sufficient to give protection in some localities will give insufficient protection in others.

The factors governing the location of lightning arresters are: the intensity and frequency of lightning storms, the location of the line in relation to natural protective features, such as tall trees, buildings, conditions of altitudes, etc., the potential of the line, since a lightning disturbance that may cause damage on a low voltage line may be unnoticed on one of higher potential.

**13. INSTALLATION OF LIGHTNING ARRESTERS.** The wiring connections of lightning arresters are of utmost importance. The discharge circuit should contain minimum impedance, and hence must furnish the shortest and most direct path from the line to ground. The most severe disturbances which an arrester is called upon to handle



are those of high frequencies, and it is therefore, imperative to eliminate all unnecessary inductance. The features favorable to low inductance are short length of conductor, large radius bends and a conductor of large surface area. For wiring high voltage arresters the use of copper tubing is strongly recommended. Such copper tubing

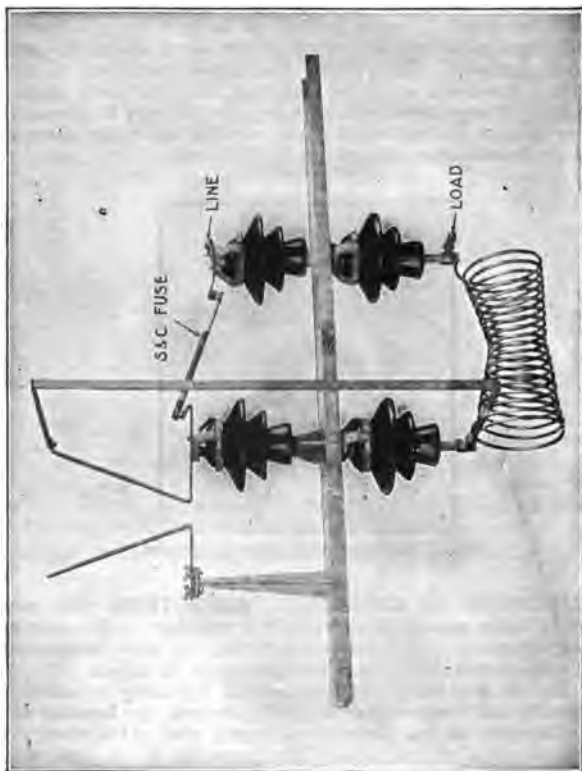

FIG. 239.—Horn type lightning arrester for constant potential circuits.

has the advantage over either copper strip or solid conductors in that it is easily supported, requires fewer insulators, and is, therefore, cheaper to install. Copper tubing connections can be designed so that all sharp bends are eliminated and there are no points where corona or brush discharge may take place.

The wiring for pole type arresters should never be wound in a spiral

coil. If this is done, the usefulness of the arrester is practically counteracted by the inductance of the wire coil. Even one turn will greatly reduce the effectiveness of the arrester and in some cases may entirely prevent its discharge. The wiring from the arrester to the ground should be as short and straight as possible. This connection may be made by copper wire, rod, or strap, and should be protected by a wood cover extending from the ground line to a point seven feet above.

When an iron pipe ground is made, the copper connection from the arrester to the pipe should be securely fastened to the top of the pipe and not carried down the inside of the pipe.

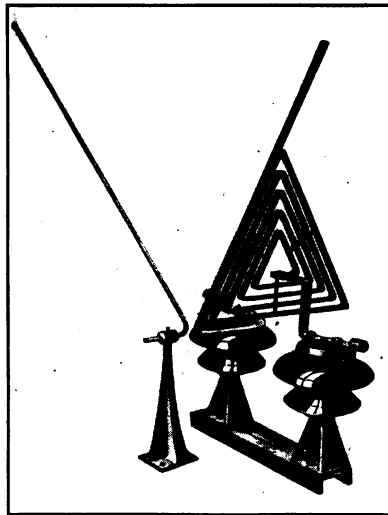

FIG. 240.—Horn gap lightning arrester combined with choke coil for constant potential circuits.

The wire should not be wound around the pipe before connecting thereto.

**Lightning arrester grounds should be kept separate from all other grounds.**

For methods of making grounds, see Arts. 22, 23, 24 and 25.

**14. HORN ARRESTERS.** Horn arresters should not be considered as true lightning arresters, but rather an insulation intentionally weak. If—due, for instance to direct stroke—the insulation of a line must fail, it is much more preferable that it should do so over a horn

arrester. Horn arresters with resistance are usually useless, except on constant current circuits, as the current of discharge is too limited to relieve the line. With no resistance, or with resistance low enough to relieve the line, synchronous apparatus will be thrown out of



FIG. 241.—Choke coil.

step and the line shut down before the arc can be extinguished. The line, however, can be immediately put into service again, which could not be done if the insulation was punctured. The place for



FIG. 242.—Choke coil.

horns, therefore, is along the pole line at short intervals, setting the gaps for very high voltage arc-over.

For constant current arc lamp circuits, horns form an excellent

arrester, as only a small current is required to relieve the line, and resistance can be used. For mercury arc rectifier arc-lamp circuits, this arrester is especially well adapted, as the multigap arrester will not operate on direct current.

A typical horn arrester is shown in Fig. 239, and a type combining the horn gap and choke coil is shown in Fig. 240.

**15. CHOKE COILS** or reactances have the function of retarding high frequency disturbances, thus giving the lightning arresters an opportunity to relieve high potential stresses before they enter the apparatus. Choke coils are not effective in retarding low frequency disturbances. Several types of choke coils are illustrated in Figs. 241, 242, 243.

**16. GROUND WIRES AND LIGHTNING RODS.** Wire conductors placed underground or insulated wire conductors surrounded by a metallic sheath and hung overhead are protected from electrostatic



FIG. 243.—Choke coil

charges due to cloud lightning. As it is generally impractical to surround the wire conductor by a metallic sheath the next best thing to do is to place some object at ground potential over the line. This may be done by stringing a grounded wire over the line. The greater the distance between the grounded wire and the line, the better partial protection is afforded the line. Dr. Steinmetz recommends that an overhead grounded wire be so placed that two imaginary lines drawn from this wire  $45^\circ$  down from the horizontal will include all line wires between them. Each additional overhead ground wire, properly placed, gives some additional protection against induced static electricity from the clouds.

The overhead grounded wire also has the function of protecting wood poles from being shattered by a direct stroke of cloud lightning. It also has the possibility of carrying a direct stroke of cloud lightning to ground, past the line wires, without shattering the insulators or causing a short circuit.

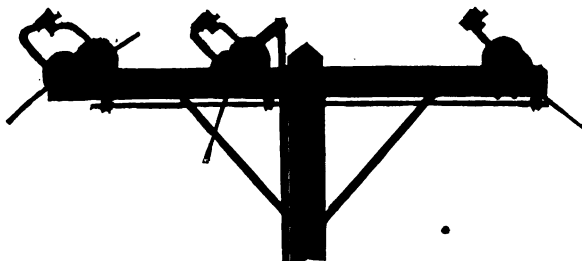

FIG. 244.—Air break 3 P. S. T. switch.



FIG. 245.—Air break S. P. S. T. disconnecting switch for 300 amperes and 35,000 volts.

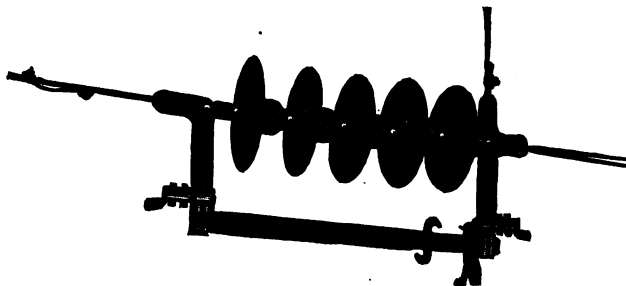

FIG. 246.—Air break S. P. S. T. disconnecting switch for 300 amperes and 90,000 volts.

Lightning rods at each pole will add a slight probability that a direct stroke will strike at the pole and not between poles.

If the overhead grounded wire is earthed at every pole, direct strokes of lightning are likely to find a more direct path to earth. The wave front of a direct stroke is usually so steep that the charge finds the natural inductance of the horizontal wire a great impedance, and consequently it is likely to side-flash to other lines and also over insulators to its natural terminum, the earth. If the earth connection is made at every third pole instead of at every pole, there is a possibility that a direct stroke will hit a midway point and have a greater distance to travel, parallel to the line wire, before it reaches the earth. The parallel movement of the charge gives electromagnetic induction on the power wires. Practically all reports of damages to lines by direct strokes confine the line damage to about seven

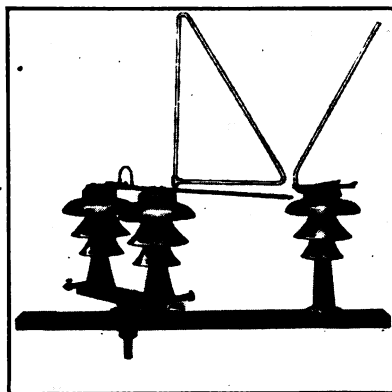

FIG. 247.—Horn gap air break S. P. S. T. switch for 300 amperes and 44,000 volts.

successive poles. Therefore, a close study of operating conditions should be made in order to determine the necessity for frequent earth connections.

**17. SWITCHES.** Switches may be divided into two general groups.

1. Air break switches.
2. Oil switches.

Air break switches are usually used as disconnecting switches and on lines of low amperage capacity may be used to open a loaded circuit or branch line. They are seldom used, however, to break short circuit currents. Several types of air break switches are illustrated in Figs. 244-247. When air break switches are used in connection with series circuits they take the forms illustrated in Figs. 248 to 251.

The switches illustrated in Figs. 248-249 are used in connection with individual arc lamps and are so arranged that each unit may be completely disconnected from the circuit without interrupting the passage of current. The switches illustrated in Figs. 250 and 251 serve the purpose of disconnecting a number of units simultaneously and are so arranged that both the main circuit and the disconnected loop are closed, thus permitting the operation of the remaining portion of the series circuit when the loop has been disconnected.

Fig. 250 is a non-automatic switch, while Fig. 251 is an automatic switch, the operation of which is as follows:



FIG. 248.—Absolute arc lamp cutout.

Let the circuit under normal conditions, which starts from the terminal *T* of a constant current dynamo or constant current transformer, pass through the series lamps *L*, etc., along the flexible conductor *J*, to the laminated contact *B* and contact plate *C*, through the lamps *N*, *N*, etc., to contact plate *C'* and laminated contact *B'*, along flexible conductor *J'*, through balance of lamps *L*, etc., to terminal *T'* of the dynamo or transformer.

The section of the above circuit which is being protected by the automatic series cut-out, extends from contact plate *C*, through lamps *N*, *N*, etc., to contact plate *C'*.

Let a break occur in the circuit protected by the cut-out, say at *O*. Immediately the full potential difference of the line will exist across the adjustable gap *G* between the carbons *E* and *E'*, the carbons being so adjusted that this potential difference will be sufficient to

break down the air gap. For an instant the current flows from T through lamps L, to carbon E, across gap G to carbon E', through solenoid coil S to R, through lamps L, to terminal T'. This condi-



FIG. 250.—Absolute arc loop cutout switch.



FIG. 249.—Absolute arc lamp cutout.

tion exists but for a moment, as the current immediately energizes the solenoid S, causing core A to be drawn up, carrying with it the porcelain insulator P and contacts B and B', thus opening the circuit



containing the lamps  $N, N$ , etc., at  $C$  and  $C'$ . At the same time the contact  $B$  makes contact with  $D$ , thus short circuiting the gap  $G$ .

Consider the break at  $O$  as having been repaired. The loop circuit is still dead and can be started by disconnecting the circuit at  $T T'$

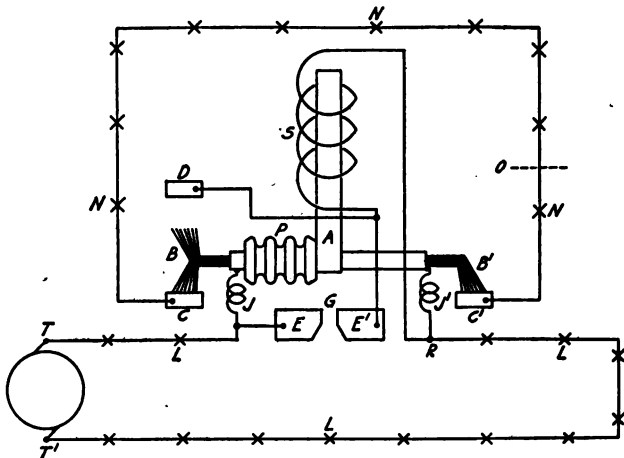

FIG. 251.—Automatic arc loop cutout switch.

for an instant, allowing the core  $A$  to drop, thus reconnecting the loop.

If, however, the circuit for any reason has not been properly repaired, or another break has occurred, an arc will again be established



FIG. 252.—Non-automatic oil switch 3 P. S. T., 100 amperes, 2,200 volts.

across gap  $G$ , the solenoid energized and the defective line again cut out in the same manner as previously explained. This procedure will continue until the defective circuit is properly closed.

Oil switches may be sub-divided into two classes:

1. Automatic.
2. Non-automatic.

An automatic oil switch is an oil switch so arranged that it will disconnect the circuit under a predetermined condition. Such switches are seldom used on pole line work, especially in systems where the kv-a. capacity of the generating system is large, as a switch that would successfully open a short circuit would be too large and expensive. There are many instances, however, where space is available and the cost permissible, in which automatic oil switches may be used to advantage to replace fuses.

In outdoor substation installation where the kv-a. capacity is sufficient to warrant the cost, and protection from overload or short

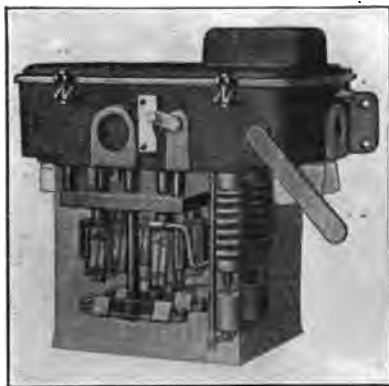

FIG. 253.—Automatic oil switch 3 P. S. T., 100 amperes, 2,200 volts.

circuit conditions is desired, automatic oil switches are in general use.

Figs. 252-254 illustrate various types of oil switches some of which may be made automatic or non-automatic by a slight change in the design of the operating mechanism.

The time switch (Fig. 255) is a semi-automatic oil or air break switch in that its operation may be controlled by a time clock and the circuits opened and closed at predetermined intervals, but is non-automatic in that its operation is independent of any phenomena occurring in the circuit.

When it is undesirable to connect branch lines to mains by fused connections or automatic switches, non-automatic pole type oil switches may be used to advantage, as their use facilitates the location of operating troubles.

**18. FUSES.** Probably no part of an electrical system is subjected to more severe conditions than is the electric fuse. Coupled to this,

is the fact, that when once installed the fuse is usually regarded as part of the distribution or transmission circuit and, with the exception of very occasional inspections, is given no operating attention.

The fuse installation therefore must not only be able to withstand all weather conditions and all kinds of varying loads, but from its very nature must operate when occasion demands and open the circuit satisfactorily.

On systems of moderate capacity the problem is not serious as there



FIG. 254.—High voltage oil switch 3 P. S. T. Design ranges from 100-800 amperes and 22,000-110,000 volts.

is no possibility of concentrating a large amount of energy in case a fault develops in the protected circuit. On larger systems, however,—those which receive energy from a generating source of relatively high capacity—the conditions are much more severe. Here the fuse must be able to operate under very heavy loads and must interrupt without damage, a flow of energy amounting to thousands of kilowatts. The interruption of the circuit under such conditions means the very rapid dissipation of the consequent heat, and in its effects this is comparable in many cases, to a violent explosion.

In addition, the heat caused by the rapid expansion of the air and

gaseous metallic vapors in the electric arc, if allowed to continue for a period of more than two or three cycles, is sufficient to destroy fuse holders, terminals, etc.

These two conditions, (a), the explosion effect at the time of operation, and (b), the fusion of terminals, etc., due to the heat of the electric arc, may be considered as the most important factors in the design of a satisfactory fuse.

Particular attention should be given these points, and the fuse construction which guards against dangerous rises in gaseous pressure, and operates to minimize the effect of heating is to be recommended. This latter condition is secured by rapid extinction of the arc formed, combined with ample heat radiating qualities.

In the design of terminals, the contacts and the insulating supports, particular attention must be directed to the current-carrying capaci-



FIG. 255.—Air break 3 P. D. T. 100 amperes, 220 volt time switch.

ties and the insulation strength. When fuses are mounted in metallic boxes, exceptional care should be exercised that arcing from the terminals to the box is made impossible. When such conditions are possible the operation of the fuse—particularly the open link type—will invariably cause a breakdown and will result in the consequent destruction of the fuse installation.

**Proper contact area** is also of great importance as a great number of fuse failures are due entirely to lack of this. When the fuse clips are light, and the current density for maximum fuse rating is high, the chances of trouble are greatly increased. When the connection is a knife blade contact, the removal and replacement of the fuse will necessarily change the value of the contact resistance, and, for this

reason, particularly on heavy current circuits, a design of fuse holder may be considered most desirable which operates on a removable hinge principle.

Light contact clips which can easily be bent or damaged by careless handling of the fuse holder should be avoided. One form of fuse contact obviates this danger by employing a special backing post, which affords adequate protection to the clip without impairing the flexibility of contact.

As the fuse is obviously the **weakest** part of the electric circuit, or, at least should be made such, particular care is necessary to secure conditions, external to the fusible strip, which shall be constant in nature, or proper operating of the circuit will be impaired.

Proper fuse testing is necessarily dependent on a clear understanding of fuse rating. There are no definite or general rules covering this, other than those issued by the Board of Fire Underwriters, which may be said to apply particularly to low voltage fuses.

All fuses, because of the principle upon which they operate, have an inverse time action, i. e., they will carry a momentary current of a much higher value than that which will cause them to operate, should the current be sustained. It is unreasonable to expect a fuse to operate with the accuracy of a circuit breaker. It would seem, however, that the method of rating fuses, as practiced by the various manufacturers, should be clearly understood by operating companies in order that a properly selected protective device may be installed.

A summation of the more important points in the general consideration of satisfactory fuse operation may be noted as follows:

(1) The type of fuse, for any given installation, should be determined by a consideration of the maximum concentration of energy, which is possible at any protected point of the distribution system.

(2) The general construction of the fuse should be such that it will be able to withstand the most severe climatic conditions without serious deterioration.

(3) The current carrying parts should be rugged, self-aligning and of sufficient capacity to carry 50% overload with a rise in temperature not to exceed 40° C.

(4) The design should be such that it will provide for the removal or the replacement of the fuse without the possibility of accidental contact with any live parts.

(5) The insulation of all current-carrying parts and particularly the insulation of the leading in wires, should be such that a breakdown between circuit and fuse box supports, or between opposite poles of the circuit, after the fuse has blown, is impossible.

The principal forms of fuses used in electrical distribution are covered by the three following classifications:

- (1) Link Fuses. (Art. 19.)
- (2) Enclosed Cartridge Fuses. (Art. 20.)
- (3) Expulsion Fuses. (Art. 21.)

**19. THE LINK FUSE** is the simplest type and consists essentially of a strip of fusible metal extended between two terminals of a fuse

block. This fuse block or holder is usually of porcelain or other suitable insulating material, arranged in two parts: (I) the enclosing body with suitable arrangement for fastening to the fuse support, and (II) the fuse holder or plug which is made removable in order to



FIG. 256.—Fuse holder for 30 amperes, 2,200 volt link fuse.

allow the replacement or inspection of the fuse. Metal boxes for enclosing the fuse base and block are employed in some designs. Unless, however, extreme care is exercised in this construction, par-

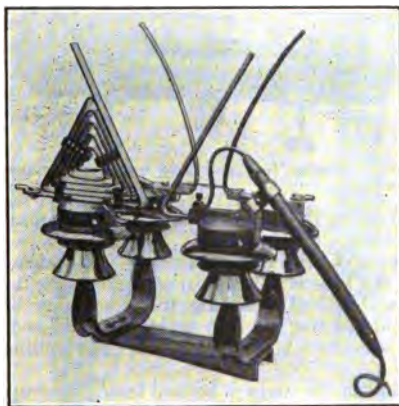

FIG. 257.—Horn gap link fuse.

ticularly relating to the breakdown distances from live parts to the metal box, this type may prove unreliable in operation.

The most satisfactory link type of fuse is that in which copper terminal clips form the ends of the fuse strip. The use of these

## Sec. 6

## PROTECTIVE APPARATUS

tends to prevent damage to the fuse strip when it is fastened to the terminal studs and also insures a better contact. In addition the fusible strip is often provided with a tubular asbestos envelope which not only protects the fuse while in service, but tends towards its more satisfactory operation when the fuse is melted. (Figs. 256 and 257.)

20. **THE ENCLOSED CARTRIDGE FUSE** consists of a fusible strip encased in an insulating tube which serves also as a container for an insulating substance which completely surrounds the fuse strip. The tube is usually made of fibre, and the filling material is composed of Calcium Sulphate (Plaster of Paris) or Calcium Carbonate (Whitening), or Levigated Amorphous Infusorial Earth, usually powdered or granular in form. A combination of any two or three, will result in a substance suitable as a heat dissipating material, but any siliceous materials such as sand or glass or any of the porcelain clays



FIG. 258.—Enclosed cartridge fuse and fuse box. 100 amperes, 2,200 volts.

are not suitable owing to the ease with which they may be fused and rendered conducting.

The filling serves the three-fold purpose: (a) of absorbing the heat liberated when the fuse is blown, (b) of condensing the vapor of the molten metal and (c) of breaking the continuity of the electric circuit. The ends of the fuse are soldered or riveted to the metal contacts which also serve to seal the tube, thus holding in the filling compound.

When a portion of the strip is turned into vapor upon the operation of an enclosed fuse, pressure results and the vapor seeks to expand through the filling material. The hot gases pass over the surfaces of the minute particles which, on account of their lower temperature, condense the gas, but when the initial expansion occurs the air entrained between the particles of filling material must find escape. To this end vents are provided in the end closures of the cartridge and in order to prevent the dislodgement of the dust and

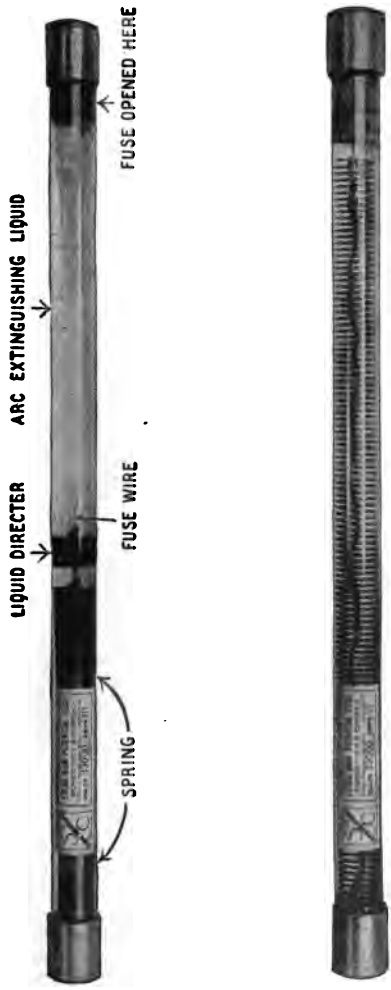

FIG. 259.—Chemical fuse. Upper cut illustrates a blown fuse. Lower cut a fuse ready for operation.



## Sec. 6

## PROTECTIVE APPARATUS

finer particles of filling, vent screens of cloth, canvas, asbestos cloth, etc., are placed within the ferrules.

In some installations the enclosed type fuse has many advantages over the simple link fuse. On account of its enclosed construction its general characteristics are more nearly uniform and therefore its operation should be far more definite. (Fig. 258.)

In addition to the standard type of enclosed fuse, several other designs are found in commercial use; one of which (Fig. 259), consists of a glass tube containing a spiral spring, the lower end of which is connected to the bottom ferrule. The upper end of the spring connects to the fuse wire, passing through a cork, the upper end of the fuse wire being connected to a short wire soldered to the cap on the top ferrule. At the top of the spiral spring and just below the cork is a funnel-shaped liquid director. The glass tube is filled with a non-inflammable liquid of high dielectric strength.

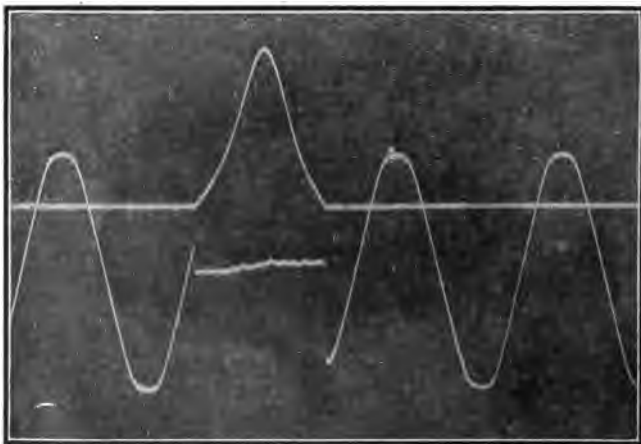

FIG. 260.—Oscillogram illustrating the action of the fuse in FIG. 259 when opening a short circuit.

The melting of the fuse wire releases the spiral spring which contracts instantaneously, drawing the fuse wire down towards the bottom of the tube and thus introducing a very large gap. Simultaneously with the introduction of this gap, the liquid extinguishes the arc and interrupts the current flow, the rapidity of its action being accelerated by the liquid director which is drawn down with the spring and so forces the liquid directly onto the moving terminal.

Another consists of a metal box filled almost completely with oil, into which the fusible strip is immersed except for a small part of its

length. (Fig. 261.) The portion exposed to the air will melt first, due to the more rapid conduction of heat by the oil; when the fuse blows an arc is established above the oil level and as the metal fuse burns down to the oil the arc will be automatically extinguished and the circuit thereby interrupted.

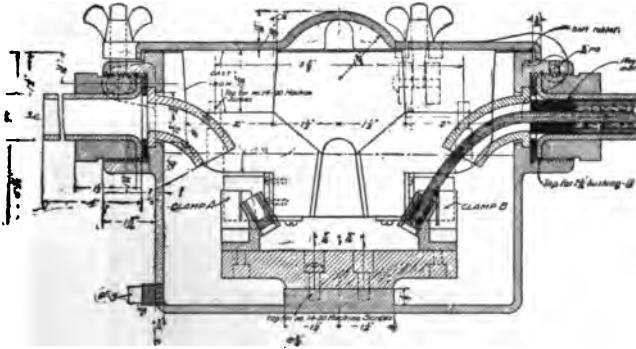

FIG. 261.—Oil fuse box showing details of construction.

The oil fuse cutout illustrated in Fig. 262 consists of an oil tank in which oil immersed contacts are provided. A removable element is designed to carry the fuse, and a vent is placed in the top of this element to permit the escape of the gases generated when the fuse operates.



FIG. 262.—Oil fuse cutout.

The removable element is designed so that it is necessary to insert it completely and then turn it before contact is made with the stationary contacts in the tank. This locks the fuse plug in position, thus protecting the operator from accidents which may occur due to refusing when a short circuit exists.

Metal boxes for enclosing and supporting the standard enclosed type of fuse are very generally used. Since there should be no liberation of metallic gaseous vapor when the fuse blows, which vapor would tend to cause a breakdown between live parts and the metal case, no special precautions are necessary to protect against such conditions.

Other materials of construction, such as asbestos lumber or impregnated wood are used and have proven more or less satisfactory.

**21. THE EXPULSION FUSE.** This type employs what is essentially an open link fuse in combination with a container having in its



FIG. 263.—Expulsion fuse block and box, 100 amperes, 2,500 volts.

construction an **explosion chamber**. This form of design utilizes the explosive action of the gases liberated when the fuse is blown, directing these gases across the arc in such a way as to extinguish it and thus rupture the circuit.

For overhead line service there are two types of expulsion fuses. One consists of **two blocks of insulating material**, between which the fusible strip is securely clamped. (Fig. 263.) Midway along the fusible strip is located an explosion chamber. Where the fuse strip passes through this chamber its cross section is reduced, resulting in a definite point at which the fusing will first take place. This

fusing point is located directly back of the discharge vent in the holder and the explosion caused when the fuse operates forces the gaseous vapors through the opening provided, thus extinguishing the arc. The melting of the fuse is usually confined to the length of the fuse strip contained in the expulsion chamber. In order to prevent injury to the block, at these points, it is usual to provide strips of non-inflammable material along the parts of the fuse which are directly in contact with the fuse holder. These strips are made



FIG. 264.—Expulsion fuse for from 6,000-22,000 volts.

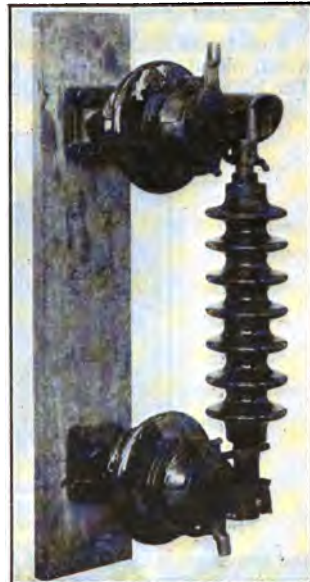

FIG. 265.—Expulsion fuse for 50 amperes, 15,000 volts.

either of asbestos lumber, of lignum vitæ or of lava and may be readily replaced at a nominal cost.

The other form of expulsion fuse in general use consists of a tubular holder which serves as a container for an open link fuse. (Figs. 264 to 267.) This holder is constructed of an insulating material, usually fiber, which is closed at one end by a metal explosion chamber. The other end of the holder is left open and provides an exit for the discharging gases when the fuse blows. The principal of operation of this type is identical to that already described.

One other type (Fig. 268), which is of comparatively recent de-

## Sec. 6

## PROTECTIVE APPARATUS

sign, employs the use of an extremely high pressure gas receptacle which is connected to one end of a special form of fusible strip; this strip being connected in the electric circuit by means of the tubular arrangement above mentioned. In its operation, this fuse melts at a predetermined point, thereby, releasing the gas from the hermetically sealed container. The gas does not support combustion and in its discharge through the arc path interrupts the circuit by violently blowing the metallic vapor through the open end of the tube. In addition, the rapid expansion of the gas cools the terminals to very low temperatures and thus prevents the burning of the metal parts.

Fuse boxes similar to those for enclosed fuses are constructed of wood, metal or asbestos, or a combination of asbestos and metal. The latter construction eliminates all metal except a skeleton frame,



FIG. 266.—Expulsion fuse and box for 60 amperes, 2,200 volt circuits.

and provision is made so that the asbestos board sides can be readily replaced in case of damage.

### GROUNDING.

22. **General.** Earth connections are necessarily made by electrolytic conduction. To obtain low resistance, it is therefore necessary to have electrolytic moisture in contact with the earth plate, or, lacking thus a fair degree of conductivity, it is necessary to have a very large area of cross section for the current. There are no dry earths that are conductors. If the earth contains no soluble substances which are electrical conductors, it is necessary to add electrolyte. The one precaution in choosing an electrolyte is to avoid one which attacks the metal conductors chemically.

It is impossible to make a rule or practice to cover all cases, but investigations have shown that the general practice of using pipe

earths can be justified in nearly every case. Coke, so often recommended for earth connections, is not a good conductor in itself. It attracts and holds moisture, but since that moisture does not contain an electrolyte in solution, it leaves the earth connection with high resistance. On the basis of the first cost, and of inspection, resistance measurements, etc., the iron pipe earth is to be recommended. Iron is the cheapest available metal and has thoroughly proven its serviceability, even when imbedded in salty marshes.

For an electrolyte, salt or washing soda is to be recommended. In the majority of conditions, salt is preferable as its resistance is less, notwithstanding that it has a greater chemical effect on the iron.



FIG. 267.—Expulsion fuse, 60 amperes, 6,600 volts.

### 23. Laws of the Resistance of Pipe Earth Connections:

#### (a) Resistance Versus Depth of Pipe.

The resistance varies approximately inversely as the depth in the conducting stratum.

#### (b) Resistance Versus Specific Resistance of the Earth.

Practically all of the resistance in the earth is in the immediate vicinity of the pipe. This resistance depends on the specific resistance of the material. The specific resistance depends upon the amount of moisture and the electrolyte in the moisture. The lowest possible resistance obtainable is secured by pouring salt water around the pipe.

#### (c) Resistance Versus Multiple Pipe Earths.

When it is desired to lower the resistance to earth below that of a single pipe earth, drive others at a distance of not less than six feet from each other. Then the total conductance is only slightly less than the sum of the individual conductances, and the total resistance is the reciprocal of the total conductance. For conditions

## Sec. 6

## PROTECTIVE APPARATUS

of uniform soil, the approximate rules may be stated: That two pipe earths connected together give one-half the resistance of one, ten pipe earths give one-tenth the resistance of one, etc.

### (d) Resistance Between Pipe Earths at Variable Distances Apart.

For distance between pipe earths up to one foot the resistance between them increases rapidly. For every additional foot, the added resistance becomes less and less. At a distance apart of six feet, the resistance has reached nearly a constant value. Stated otherwise, the resistance between two pipe earths at any distance apart greater than six feet is nearly equal to the sum of the isolated resistance of each.



FIG. 268.—Compression fuse and box for 200 amperes, 2,500 volts.

### (e) Potential Distribution Around a Pipe Earth.

Since the resistance of a pipe earth lies mostly in the immediate vicinity of the pipe, the greatest potential drop when the current flows will also be concentrated there. Heating and drying out will tend to magnify this value.

### (f) Ampere-hour Capacity of a Pipe Earth.

The quantity of electricity that can be passed through a pipe earth without materially changing its resistance, increases directly with the wetness of the earth in contact with the iron, and the area of the iron surface exposed to the passage of the current; and decreases as the resistance of the earth in contact with the pipe increases. Certain critical values of current may be carried continuously by a pipe earth without varying the resistance. The higher the current above this critical value, the more rapid the drying out. To increase the ampere-hour capacity it is necessary to keep the pipe earth wet with salt water.

**(g) Resistance of Pipe Earth Versus Diameter of Pipe.**

The resistance of a pipe earth does not decrease in direct proportion to the increase in the diameter of the pipe. Two pipes driven side by side and connected together will have only a slightly less resistance to earth than one pipe; a pipe two inches in diameter has a resistance only about six to twelve percent less than that of a pipe one inch in diameter.

**(h) Minimum Inductance of Leads to Pipe Earths.**

The connecting wire between the conductor or apparatus to be grounded and the ground should be as short as possible, by taking as direct and straight a path as possible.

Loops in the lead introduce unnecessary impedance to high frequency impulses.

The inductance of a conductor to high frequency may be said to decrease with the increase of the surface area. A hollow metal tube conducts as well as a solid wire of the same circumference. A flat strip is an economical way of getting large surface with a small weight of metal. The minimum degree of inductance with the minimum weight of metal is obtained by using separated parallel wires. Copper is best on account of its conductivity and durability, but, since only the surface layer of metal carries the current, galvanized iron may be used in some cases.

**24. Making the Earth Connection.**

(a) **General.** To make the earth connection, take plain pieces of standard one and two inch pipe and drive them as much over six feet into the ground as is convenient. Solid metal spear heads and sleeve joints on the pipe, which make holes larger than the diameter of the pipe, should not be used, as the contact resistance is thereby excessively increased. If the pipe drives with too much difficulty, a solid crowbar may first be used to open up the hole. If there is no stand available for starting a pipe eight feet or more long, a shorter pipe, slightly larger in diameter, may be driven several feet and then withdrawn to make a start for the longer pipe.

After the pipe is driven to place, a basin should be scooped out of the surface of the earth around the pipe and salt brine poured in. The amount of salt water needed depends upon the local conditions and also upon the importance of the ground connection.

Where the resistance of a pipe earth is less than 100 ohms without salt, a bucket full of brine may suffice. Where the pipe earth does not reach moisture below, and the resistance, therefore, is quite high, several buckets of brine may be necessary. A few handfuls of crystal salt should also be placed around the pipe in the basin.

Whether the basin is to be filled with dirt or made permanent by the use of a tile with a cover, depends upon the importance of the earth connection.

The connection to the ground from the system or the apparatus to be grounded should be made by as direct a path as possible and with a copper conductor of sufficient area to take care of the maximum discharge which may occur at that point. Angles and short curves



Sec. 6

PROTECTIVE APPARATUS

should be reduced to a minimum and loops in the connecting conductor should be carefully avoided as they introduce unnecessary impedance to the high frequency impulses.

The connecting wires should be attached to a pipe or pipes by first making a good, mechanically strong connection and then well



FIG. 269.—Ground cone.

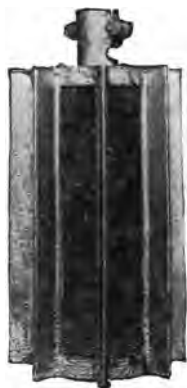

FIG. 270.—Ground box.



FIG. 271.—Ground plate.

soldering the joint. The point of connection should be at some point on the pipe above the deposit of salt in the basin in order to avoid any voltaic action between the copper and iron.

Ground wires should not be run through iron conduits. If the pipe earths are at some distance from the apparatus to be grounded,

the ground wire may be run buried in the earth, but such connection should be avoided and should be frequently inspected for possible deterioration of the conductor.

(b) **Earth Connection for A. C. Lightning Arresters.** In general, drive two or three iron pipes into the earth at a point near the location of the lightning arrester. Then drive other pipes at a minimum distance of six feet apart encircling the station or pole structure, and connect all of them with a common wire. In choosing the size of conductor for the common wire connecting the pipe earths, consideration must be given to the possible maximum discharge which it may be required to handle and the size chosen accordingly. This common ground conductor should be protected from possible electrolytic action.

(c) **Grounding Secondaries.** When the secondaries of distributing circuits are grounded, the connection should be made as near the transformer pole as possible, and, if it is on the same pole as a transformer, it may be connected to the earth connection of the transformer case, care being taken that this earth connection is sufficiently good for the purpose.

Secondary ground connections should be kept separate from lightning arrester grounds and should be protected by a wood cover extending from the ground line to a point seven feet above.

(d) **Grounding Transformer Cases.** When grounding transformer cases the connection should be made solidly and of sufficient size to take care of any possible breakdown. Transformers on poles may be grounded to one pipe.

(e) **Water Pipe Grounds.** In any system of grounding it is advisable, where possible, to make a permanent connection to a water supply system.

This may be accomplished by fastening and soldering a pipe clamp securely to the pipe and then soldering the ground wire to the clamp. When a flat copper strap is used for a ground connection it may be clamped securely to the pipe and soldered.

**25. Testing Grounds.** The greatest difficulty in making ground connections is in obtaining reliable grounds. When rigid and permanent connections can be made to water piping systems, such connections will be found to give the most satisfactory grounds. It is generally difficult to obtain such connections to the water piping system, except where the ground is made on a consumer's premises and the consumer has also a water service. In making ground connections outside, it will, in practically all cases, be necessary to use some form of ground plate or ground rod. The efficiency of these methods of grounding depends almost entirely on the nature of the soil, such grounds, unless made in permanently damp soils, being practically useless.

It is generally considered that a ground is satisfactory if the resistance is less than twenty (20) ohms. Therefore, in order to determine whether or not satisfactory grounds have been obtained, resistance readings should be made. In taking such readings, if a

## Sec. 6

## PROTECTIVE APPARATUS

water piping system is available, so that a test wire can be attached to a water hydrant or service cock, the resistance can be measured between the ground to be tested and the water piping system.

A convenient method of making this test is as follows:

After the ground has been installed on the neutral wire of the 220-volt secondary system, or on one leg of the 110-volt secondary system, connect the ungrounded leg of the system through a 5-ampere fuse to an available point on the water piping system. If sufficient current flows to blow this 5-ampere fuse the ground connection may be considered satisfactory.

If the ground wire is installed on the neutral wire of a 3-wire, 440-volt secondary system, or on one leg of a 220-volt system, and connections are made as above, the current flowing should be sufficient to blow a 10-ampere fuse.

## BIBLIOGRAPHY

- A. I. E. E., June, 1907. Steinmetz.
- A. I. E. E., June, 1907-12. Creighton.
- General Electric Review, Feb., 1913.
- Electric Bond & Share Co.
- Publications of Various Manufacturers.

## **SECTION 7**

**SYSTEMS OF DISTRIBUTION AND  
TRANSMISSION**

**ELECTRICAL CALCULATIONS**

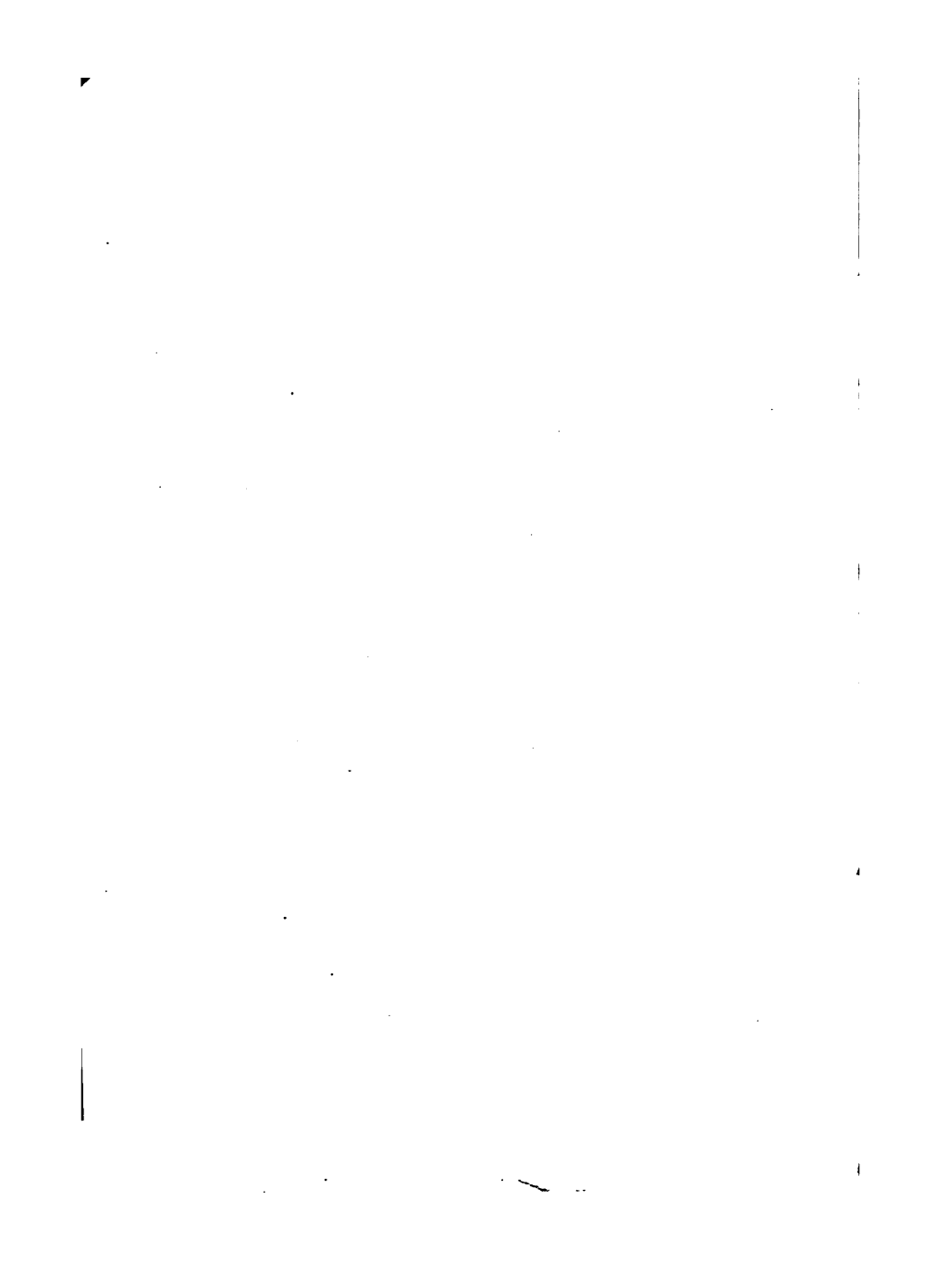

## SECTION 7

### SYSTEMS OF DISTRIBUTION AND TRANSMISSION

#### TABLE OF CONTENTS

	ARTICLE
<b>Introduction</b>	
<b>Description of Systems</b> .....	
Direct Current .....	1
Direct Current, Two-Wire System .....	2
The Edison Three-Wire System .....	3
The Direct Current Series Arc Lighting System .....	4
The Thury Direct Current Series System .....	5
Alternating Current .....	6
The Single-Phase System .....	7
The Single-Phase Two-Wire System .....	8
The Single-Phase Three-Wire System .....	9
The Two-Phase System .....	10
The Two-Phase Three-Wire System .....	11
The Two-Phase Four-Wire System .....	12
The Two-Phase Five-Wire System .....	13
The Three-Phase System .....	14
The Three-Phase Three-Wire System .....	15
The Three-Phase Four-Wire System .....	16
Comparison of "Y" and " $\Delta$ " Transformer Connections ..	17
The Alternating Current Series System .....	18
<b>Comparative Weight of Conductors Necessary in Various Systems</b> .....	19
<b>Vectors and Vector Diagrams</b>	
General Discussion .....	20
Vector Addition .....	21
Direction of Arrows .....	22
Single-Phase Transmission .....	23
Two-Phase Four-Wire System .....	24
Two-Phase Three-Wire System .....	25
Three-Phase "Y" Connected System .....	26
Three-Phase " $\Delta$ " Connected System .....	27
Effect of Charging Current on Line Calculations .....	28
<b>Inductance Formulae</b> .....	29
<b>Capacity Formulae</b> .....	30
<b>Methods of Calculating Transmission Losses</b>	
General .....	31
Direct Current Two-Wire System .....	32

	ARTICLE
Two-Wire Direct Current Railway System.....	33
The Edison Three-Wire System.....	34
Direct Current Series System.....	35
Calculation of Alternating Current Systems.....	36
Explanation of the Line Loss Tables.....	37
Single-Phase Two-Wire System.....	38
Single-Phase Three-Wire System.....	39
Two-Phase Three-Wire System.....	40
Three-Phase Transmission.....	41
Graphical Solution of a Three-Phase Transmission Line.....	42
Additions to Existing Systems.....	43
Alternating Current Series System.....	44
Choice of Voltage on Transmission Lines.....	45
Corona and Corona Loss.....	46
Locating the Center of Distribution.....	47
<b>Transformer Calculations</b>	
Calculation of Transformer Capacity.....	48
Calculation of Transformer Regulation.....	49
Calculation of Transformer Efficiency.....	50
<b>Voltage Regulators</b>	
General.....	51
Regulation.....	52
Single-Phase System.....	53
Two-Phase System.....	54
Three-Phase Three-Wire System.....	55
Three-Phase Four-Wire System.....	56
Regulator Capacity.....	57
<b>Resultant Power-Factors.....</b>	<b>58</b>
<b>Power-Factors of Various Types of Loads.....</b>	<b>59</b>
<b>Economics of Transmission.....</b>	<b>60</b>
<b>Transpositions.....</b>	<b>61</b>
<b>Constant Voltage Transmission.....</b>	<b>62</b>
<b>Sparking Distances.....</b>	<b>63</b>

## INTRODUCTION

No attempt will be made in this section to cover the solution of all the electrical problems involved in the transmission of electrical energy. However, fundamental formulæ are included, together with definitions of the various standard systems of distribution, and the use of the formulæ included will enable the solution of the majority of electrical problems encountered.

The tables have been arranged to facilitate the use of a slide rule and the values contained are well within its accuracy.

### DEFINITIONS OF TRANSMISSION AND DISTRIBUTING SYSTEMS.

1. **Direct Current** is unidirectional current. It may be constant, or periodically fluctuating, as a rectified alternating current. A **continuous current** is a steady non-pulsating direct current. In reality, the commonly so-called direct current systems more nearly approach the definition of continuous current than direct current. Therefore, in the following paragraphs continuous and direct current systems alike will be termed **Direct Current Systems**.

2. **The Two-Wire Direct Current System** (Fig. 272) consists of a two-wire multiple circuit upon which, when used for light and power, is maintained a constant potential difference of from 110 to 550 volts. Such systems operated at 220 volts have been used to a large extent in isolated plants. These, however, are being succeeded by the three-wire direct or alternating current distributing systems. For **railway work** (Fig. 273) a constant potential multiple circuit is maintained, using the trolley contact wire or a third rail as the positive conductor, and the track rail as the negative conductor. The track rail is made the negative in order that electrolytic action, which occurs where current leaves a conducting body, will be confined to a section close to the power house. In such systems 600 volt circuits are the usual standard. However, on interurban railway work 600, 750, 1200, 1500 and 2400 volt circuits have been used depending upon local conditions, such as the length of the line, the volume of traffic, train schedule, topography, etc.

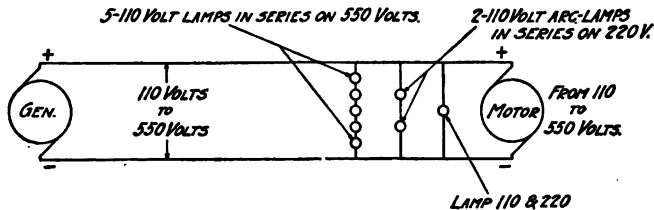

Fig. 272.—D. C. two-wire system.



3. The Edison Three-Wire System is essentially two, two-wire systems, in which the positive of one and the negative of the other circuit are combined in one wire known as the neutral. It is a development of the two-wire direct current system. Its use allows the distribution of the same amount of energy at the same usable voltage as that of the two-wire system and at a great saving in copper. (Double voltage being maintained between the outside wires). The neutral wire carries only the unbalanced load of the system. As adapted to central station practice, it is usual to connect the wires in a network (Fig. 274) and feeders are extended from the generating station to the various load centers. It is necessary to extend the neutral from the station only to points where conditions of unbalanced load are known to exist. Because of the small areas covered by isolated plants, a system of mains and branches is used in such installations instead of a net-work.

The difference of potential between the outside wires of the three-wire direct current system is usually maintained at 220 volts; and that between either outside wire and the neutral is 110 volts.

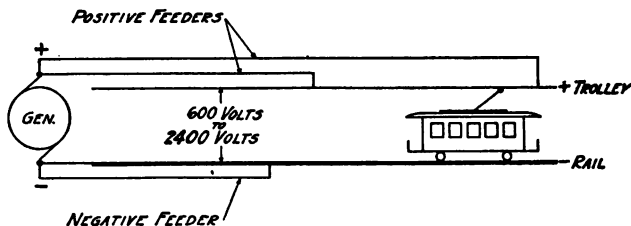

Fig. 273.—D. C. railway system.

4. The Direct Current Series Lighting System (Fig. 275) is one in which the current is maintained at a constant value; the voltage varies with the number and characteristics of the lighting units connected. The system consists essentially of a single continuous conductor run from, and returning to, the source of energy. In this way the area to be served is covered, and into the circuit are connected in series the arc or incandescent lighting units. This system is usually confined to the transmission of energy for street lighting.

5. The Thury Direct Current Series System is similar in character to the direct current series lighting system, except that the circuits are of higher voltage and greater kw. capacity. The source of energy consists of a number of generators connected in series by which means high direct current voltages are obtained. This is distinctively a system for the distribution of energy for power and as such, is used to some extent in Europe. The problem of insulating the generating and the receiving apparatus is difficult, because of the high voltages maintained.

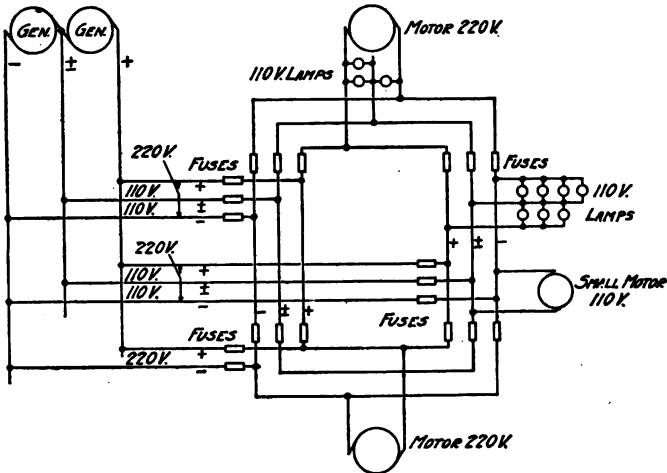

Fig. 274.—Edison three-wire system.

**6. Alternating Current.** An alternating current or e.m.f. is a current or e.m.f. which, when plotted against time in rectangular co-ordinates, consists of half waves of equal area in successively opposite directions from the zero line.

A Cycle is two immediately succeeding half waves.

The number of cycles per second is known as the **frequency**. Standard American frequencies for the distribution of energy for light and power are 25 and 60 cycles.

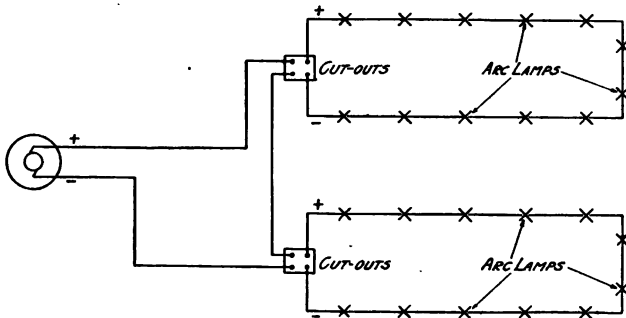

Fig. 275.—Direct current series arc lighting system.

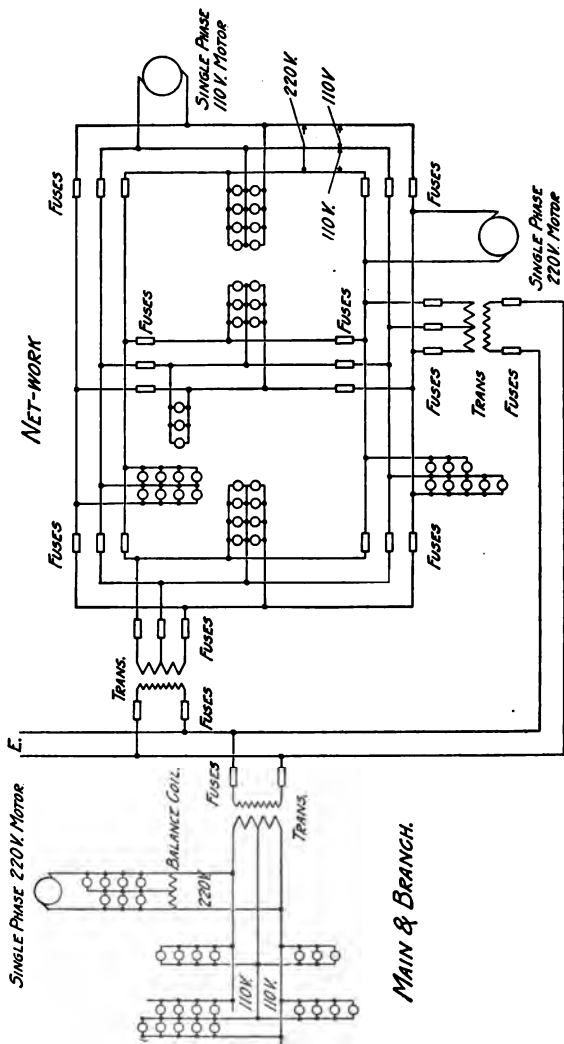

Fig. 276.—Single-phase two and three-wire system. The fuses on the secondary side of the transformers may be omitted.

**7. Single-Phase System.** A term characterizing a simple alternating current circuit energized by a single alternating e.m.f. Such a circuit is usually supplied through two wires. The currents in these two wires, counted positively outwards from the source, differ in phase by 180 degrees or half a cycle.

**8. The Alternating Current Single-Phase Two-Wire System** (Fig. 276) is similar in circuit arrangement to the direct current two wire system. When used for the distribution of energy for light and power, it is usually part of a polyphase system. For railway installations potentials of 11,000 volts are in successful operation, confined however to systems using a trolley contact wire. When a single phase system is used for the distribution of energy for light and power, the following **secondary connections** can be made:

Single-phase two-wire.

Single-phase three-wire.

**9. The Single-Phase Three-Wire System** (Fig. 276) is nearly always confined to secondary distribution and is similar in circuit arrangement to the Edison Direct Current three wire system, especially when interconnected to form a network. In such a network the transformer secondaries are connected at those points to which, in an Edison three-wire system, feeders would be extended.

Main and branch distribution connected to a single transformer is more often used, because of the fact that failures in such a system confine themselves locally, without disturbing a number of consumers, as may occur in a network.

When such a system is used, it is generally a part of a polyphase primary distributing system.

**10. A Two-Phase System** is one in which the energy is continuous and in which two alternating voltages are impressed upon the receiving circuit. The maximum values of these two voltages are 90 electrical degrees apart in time phase.

**11. The Two-Phase Three-Wire System** (Fig. 277) consists of two single phase circuits (differing in phase by an angle of 90°) supplying energy over three wires, one wire acting as the common return for both circuits. When the load on such a system is balanced, the current in the common wire is 41 percent greater than that in each outside wire.

The phenomena of unbalanced voltage and phase angle distortion in this system depend upon many variables, some of which follow: the amount of the load, the proportion of the load on each phase, the power-factor of the circuit, the voltage, the frequency, the spacing and diameter of conductors and the length of line. (Art. 25).

The above phenomena may be negligible with a low power-factor load if the low power-factor load is a small part of the total load on a circuit having a high power-factor; and if the conductors are spaced close together, fairly long lines may be used without trouble from this cause.

The system has been adopted to some extent for the reason that

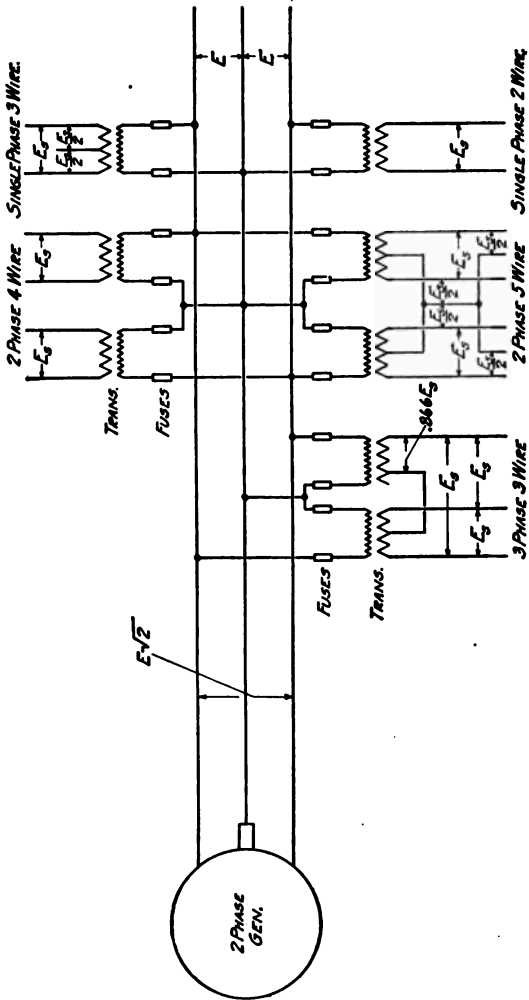

Fig. 277.—Two-phase, three-wire system.

more energy can be transmitted over the same weight of conductor than is possible in a two-phase four-wire system. Against this, however, must be considered the necessity for higher insulation, as the voltage between the outside phase wires is 41 percent greater than the single phase voltages.

The following secondary connections can be made to such a system:

- Single-phase, two-wire.
- Single-phase, three-wire.
- Two-phase, three-wire.
- Two-phase, four-wire.
- Two-phase, five-wire.
- Three-phase, three-wire.

**12. The Two-Phase, Four-Wire System** (Fig. 278) differs from the two-phase, three wire system in that two independent single-phase circuits are maintained (differing in phase by an angle of  $90^\circ$ ) supplying energy over four wires.

This system is being extensively used for power distribution. For transmission its use is gradually giving way to three-phase, three- and four-wire systems, by the use of which a considerable saving in conductor material is made possible.

The following secondary connections may be made to a 2-phase 4-wire system.

- Single-phase, two-wire.
- Single-phase, three-wire.
- Two-phase, three-wire.
- Two-phase, four-wire.
- Two-phase, five-wire.
- Three-phase, three-wire.

**13. The Two-Phase, Five-Wire System** (Figs. 277 and 278) is a two-phase secondary system in which the middle points of the transformers in each phase are connected together. From which connection the fifth wire is run.

This establishes two single-phase, three-wire systems with a common neutral. Such a combination is sometimes used where power and light are to be supplied from the same transformer bank.

**14. A Three-Phase System** is one in which the energy is continuous and in which three alternating voltages are impressed upon the receiving circuit. The maximum values of each of the three alternating voltages occur 120 electrical degrees apart in time phase.

**15. The Three-Phase, Three-Wire System** (Fig. 279) consists of three single phase circuits, respectively differing in phase by angles of  $120^\circ$  and supplying energy over three wires.

In such a system the algebraic sum of the current in all three wires is zero at any instant, the algebraic sum of the current in any two wires is equal, but opposite to that in the third wire. The effective voltages between all three wires are equal.

The system is generally used for transmission work, for the reason

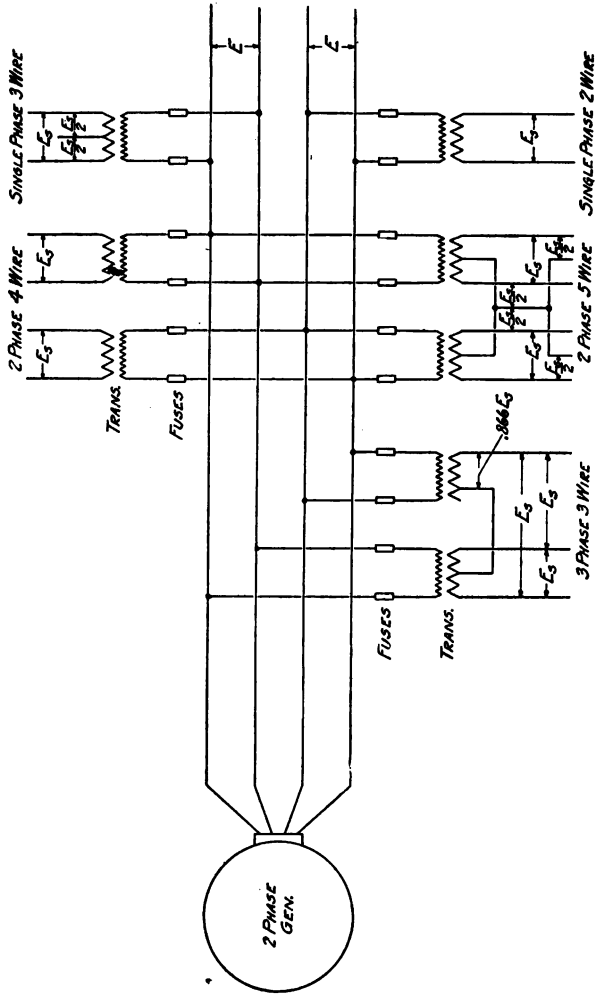

Fig. 278.—Two-phase, four-wire system.

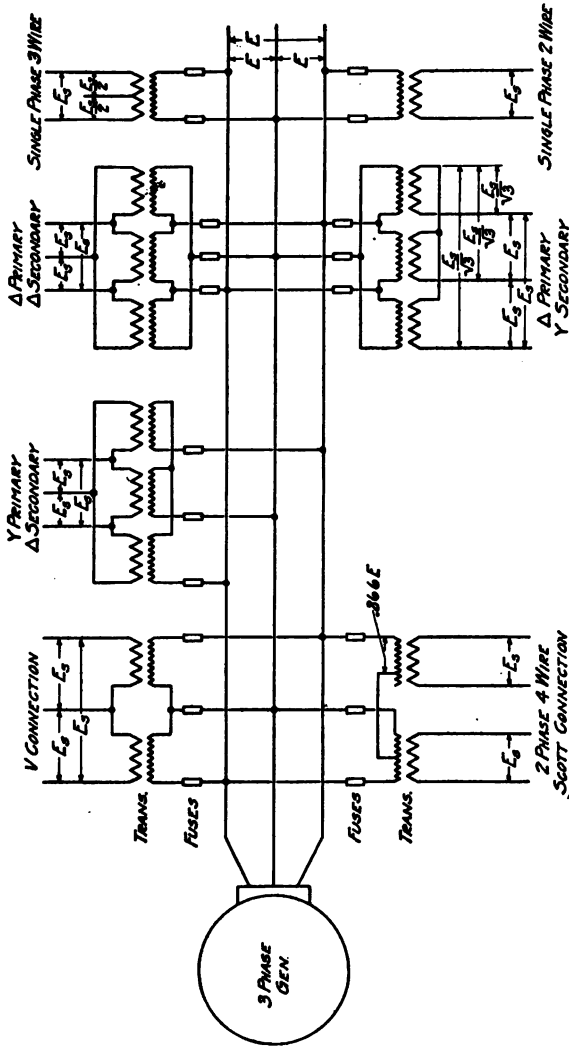

FIG. 279.—Three-phase, three-wire system.



that from the standpoint of conductor material, it affords the most economic method for the transmission of electrical energy.

Transformers at the source of supply may be connected either Y or "Δ" without affecting the method of connecting the transformers at the point of energy consumption (termed the "receiver" end).

Transformers are arranged in "Δ" (Fig. 279) by connecting three single transformers or three coils of a three-phase transformer, in such manner that a closed series circuit is formed.

The three line wires of the three-phase system are then tapped respectively to the points at which the transformers have been connected together.

Transformers are arranged in Y or star (Fig. 279) by connecting together one terminal of each of three single-phase transformers or one wire of each of the three coils of a three-phase transformer. The three line wires of the three-phase system are tapped one to each of the unconnected wires from each of the three coils.

When connecting transformers to a three-phase system, the phase relations must be maintained as illustrated in Sec. 6, Part 1, Art. 36.

The following secondary connections can be made to a three-phase three-wire system:

- Single-phase, two-wire.  
                          three-wire.
- Two-phase, three-wire.  
                          four-wire.  
                          five-wire.
- Three-phase, three-wire.  
                          four-wire.

The connection "Y" primary and "Y" secondary is seldom used, except in a three-phase, four-wire primary and secondary system; the disadvantage being that the third harmonic magnetizing current of the transformers distorts the voltage distribution, also the neutral is unstable, and unbalanced loads will force it to shift, reducing the voltage on the most heavily loaded phase.

When a "Δ" secondary is used with a "Y" primary, the third harmonics circulate in the closed "Δ" and preserve the voltage distribution.

In a three-phase, four-wire system, the third harmonic magnetizing current flows through the neutral wire and the voltage distribution on the transformer will be undisturbed.

**16. The Three-Phase, Four-Wire System** (Fig. 280) is three single-phase circuits, respectively differing in phase by angles of 120° and supplying energy over four wires. In such a system standard voltage transformers may be connected in "Y" and the advantage of the higher "Δ" distributing voltage be obtained. The fourth wire is necessary, as it is impossible to maintain single-phase loads absolutely balanced at each point of the distributing system. Unbalancing will cause considerable distortion in voltage, similar

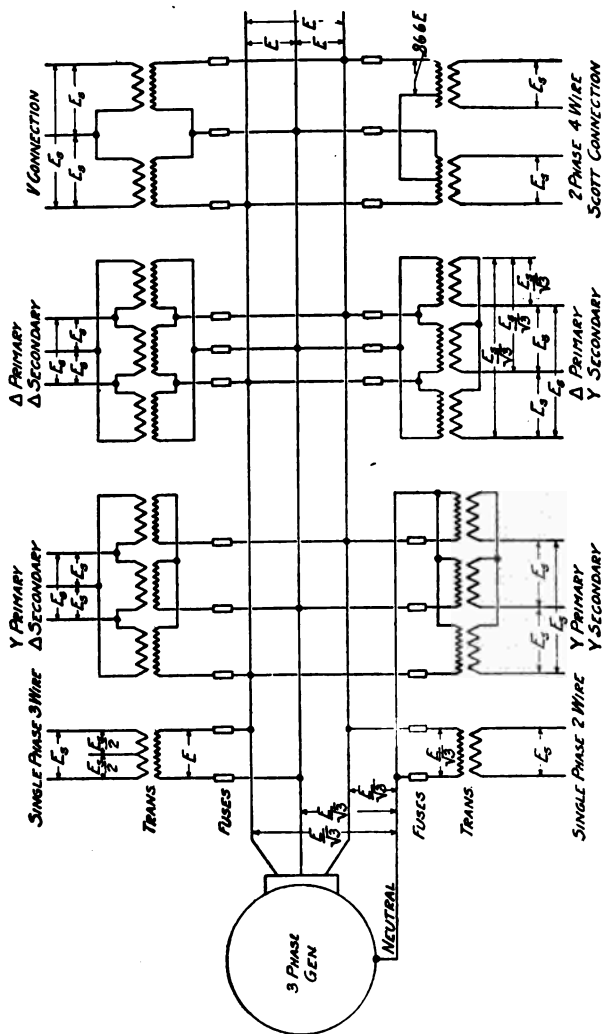

Fig. 280.—Three-phase, four-wire system.

in effect to the opening of the neutral of an unbalanced Edison three wire system. The following secondary connections may be made to a three-phase four-wire system:

- Single-phase, two-wire.  
                  three-wire.
- Two-phase, three-wire.  
                  four-wire.  
                  five-wire.
- Three-phase, three-wire.  
                  four-wire.

#### 17. Comparisons of the Relative Merits of "Y" and "Δ" Transformer Connections.

(1) When transformers are connected in "Δ" a disabled transformer may be cut out and the remaining transformers will continue to operate, in open "Δ" at reduced capacity without otherwise affecting the system. When connected in "Y," one transformer, if cut out, will completely disable the secondary system. It is not advisable to operate transformers in open "Δ" continuously; for under such circumstances unbalanced electrostatic conditions exist, which may cause high frequency disturbances.

(2) When transformers are connected in "Y" or in accordance with the "Scott" method, the coils, or parts of coils are in series between phase wires, and, should break-downs occur, one transformer may act as a reactance in series with line capacity, causing high voltage disturbances. Such occurrences are confined to cases in which one transformer bank is used, and seldom occur when two or more transformer banks are connected in parallel. Transformers connected in "Δ" are free from such disturbances.

(3) "Y" connected systems, operated with a grounded neutral, limit the voltage which may occur between the conductor and ground. However, should a ground develop on one phase, a short circuit will result. When operating ungrounded, a ground developing on one phase increases the potential between the other two phases and the ground.

18. The Alternating Current Series System (Fig. 275) is similar in type to the direct current series system and its use is generally confined to the supply of energy for street lighting. It is more flexible than the direct current system, in that transformers may be installed which not only protect the receiving apparatus from the high voltage of the system, but permit the use of apparatus requiring a current value other than that of the main system.

#### 19. COMPARATIVE WEIGHT OF CONDUCTORS NECESSARY IN VARIOUS SYSTEMS.

The values given in Table 58 are based on the following assumptions: similar conducting material, equal voltages at the lamps or other receivers, equal amounts of power transmitted, equal line losses, unity power-factor, and balanced conditions. The weight of the conductors of a two-wire direct current system has been assumed to be 100 percent.

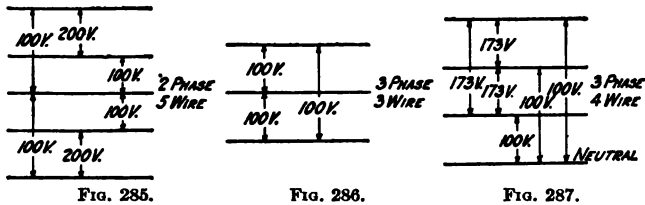
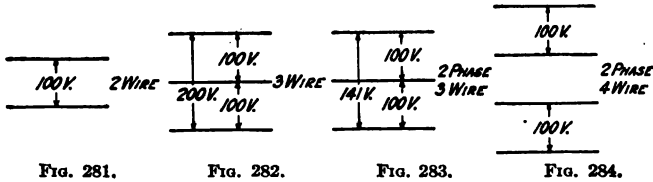

**TABLE 58**  
**COMPARISON OF CONDUCTOR WEIGHTS FOR**  
**VARIOUS SYSTEMS**

System	Size of wire	Compared to 2 Wire D. C. Per Cent.	Diagram
2 wire D. C. ....		100.00	Fig. 281
3 wire D. C. ....	Neutral equal to outside	37.50	Fig. 282
3 wire D. C. ....	Neutral one-half outside	31.25	Fig. 282
Single phase A. C. two wire	..	100.00	Fig. 281
Single phase A. C. three wire	Neutral equal to outside	37.50	Fig. 282
Single phase A. C. three wire	Neutral one-half outside	31.25	Fig. 282
Two phase A. C. three wire	Common wire equal to outside	75.00	Fig. 283
Two phase A. C. three wire	Common wire 1.41 times outside	72.90	Fig. 283
Two phase A. C. four wire	..	100.00	Fig. 284
Two phase A. C. five wire	Neutral equal to outside	31.25	Fig. 285
Two phase A. C. five wire	Neutral one-half outside	28.12	Fig. 285
Three phase A. C. three wire	..	75.00	Fig. 286
Three phase A. C. four wire	Neutral equal to outside	33.33	Fig. 287
Three phase A. C. four wire	Neutral one-half outside	29.16	Fig. 287

**20. VECTORS AND VECTOR DIAGRAMS.** The solution of many alternating current problems is greatly simplified by the use of vectors. A vector is a quantity which has both magnitude and

Sec. 7

ELECTRICAL CALCULATIONS

direction. It may be defined by giving its components in the direction of arbitrarily chosen axes of reference, or by its angular deviation from and projection on some given reference axes. The latter definition is illustrated in Fig. 288.

Draw the lines  $O'O'$  and  $ef$  at right angles through the point  $O$ . Draw a line  $OA$  from the point  $O$  and consider it to be rotating in a counter-clockwise direction at an angular velocity of  $\omega$ .  $\theta$  is the angle in radians between the rotating line  $OA$  and the reference line  $O'O'$ . (One radian is an angle in which the length of the circular arc and radius are equal. There are  $2\pi$  radians in one circumference, therefore, one radian equals  $57.295^\circ$  and the trigonometric functions apply to angles measured in radians as well as to angles measured in degrees.) At every instant in its rotation there

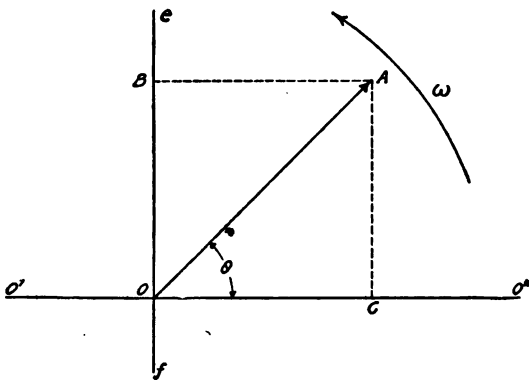

FIG. 288.

is a projection of the line  $OA$  on  $ef$  equal to  $OB$ , but  $OB$  equals  $AC$  and  $AC = OA \sin \theta$ . If  $O'O'$  is considered as the instant of zero time, and values of  $\theta$  as abscissas, and corresponding values of  $OB$  as ordinates are plotted on rectangular co-ordinates, the trace or curve shown in Fig. 289 is produced, which is known as the curve of sines.

When there are a number of these curves formed by various lines, all rotating at the same velocity, the sum of all of them at any instant can be obtained by considering the rotation stopped and adding the lines one to another, maintaining, however, the angular relation to  $O'O'$  as shown in Fig. 290. In each case the projection on  $ef$  is equal to the length of the line to be projected, times the sine of the angle between the line and  $O'O'$ , therefore, the sum of these projections will be equal to the projection of the line  $N$  on the line  $ef$ .

Vectors may be applied to the solution of alternating current prob-

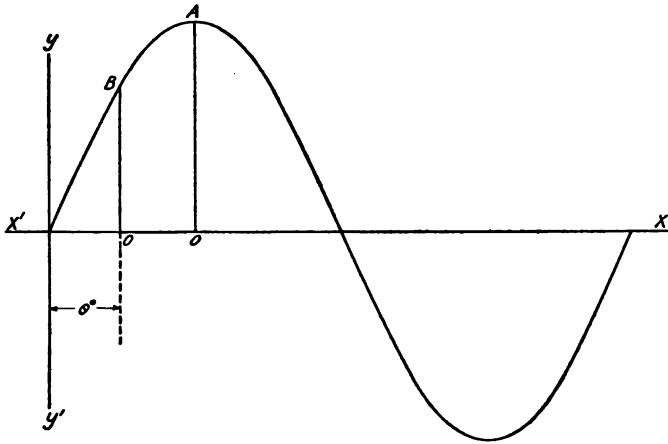

Fig. 289.

lems since the design of alternating current machinery is such that it produces voltage and current waves which very closely approximate the curve of sines, and because the curve of sines is the result of plotting the formula  $Y = A \text{ Sine } X$ , which is deduced from the vector, it holds that the vector represents alternating current and voltage variation.

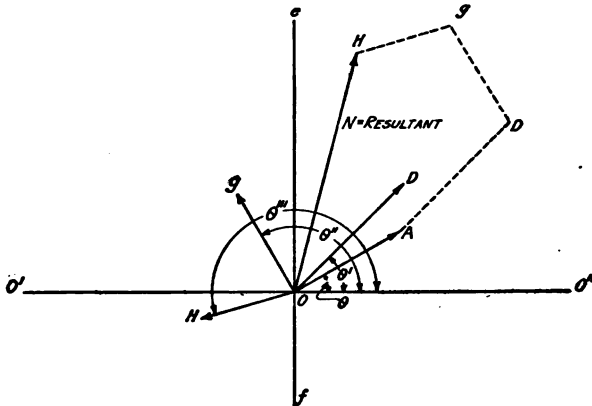

FIG. 290.

Further, the vector represents the **maximum values** of an alternating voltage or current wave, but since the effective values of sine waves—those values read on voltmeters and ammeters—are related to the maximum values as follows:  $E_{\text{eff}} = \frac{E_{\text{max.}}}{\sqrt{2}}$ ; it follows that the

effective values may be used directly, instead of multiplying the effective value by  $\sqrt{2}$  to obtain the maximum value, then applying the resulting values to the vector analysis and finally dividing the solution by the  $\sqrt{2}$  to obtain the result as an effective value.

**21. Vector Additions.** Vectors representing current and vectors representing voltage cannot be added vectorally, *i.e.*, vectors representing the same physical phenomenon only can be added or subtracted. A vector representing a voltage generated in an alternator winding may be added to, or subtracted from, the vector representing the voltage drop due to a current flowing through a resistance, an inductance, or a capacity, but not to the vector representing the current itself.

In all the following vector diagrams the vectors are considered as that part of the total voltages absorbed in resistance, inductance, etc., and not the counter e.m.f. induced, because these latter values are  $180^\circ$  out of phase with the absorbed voltage and would needlessly complicate the diagrams.

**22. Direction of Arrows.** The arrow heads on the ends of vectors when taken in connection with the angular deviation from the reference axis of zero time,  $O'O''$  (Fig. 288) indicate the instantaneous direction of voltage, or the instantaneous direction of current flow with respect to an arbitrarily chosen point.\*

The direction of arrows in a vector diagram may be selected as follows: Take any point in the circuit and consider it the reference basis; currents flowing away from this point are considered positive, and flowing towards it, negative.

Voltages above this reference point are positive, and below negative. The arrows on the end of the vectors are always drawn furthest away from the reference point.

As an example the end of  $rI_1$  at the dotted line, Fig. 293, is taken as the reference point. The arrow heads on all vectors must necessarily be away from this point. If the ends of  $\omega LI_1$  and  $\omega LI_2$  had been taken as reference points, all the vectors would be reversed but the resulting values would be the same.

The manner of choosing a reference point is merely that of locating one that is most convenient as the analysis depends upon the relative and not the actual location of the various quantities in the problem.

**23. Single-Phase Transmission.** (Fig. 291.) Draw the vector  $E$  from the origin  $O$  to a scale proportional to the voltage at the receiver, draw the vector  $I$  to a scale proportional to the current

\* By "direction" is meant the flow toward or away from a given point, and not direction in space.

at the receiver and at an angle  $\theta^\circ$  from  $E$ , where  $\theta$  is the angle, the cosine of which is the power factor of the load. From the end of the vector  $E$ , and parallel to vector  $I$ , draw a line  $rI$  to the same scale as  $E$ ,  $rI$  being the product of the total resistance of both line wires and the load current. From the end of the line  $rI$  and in phase  $90^\circ$  ahead of the line  $I$  draw the line  $\omega LI$  to the same scale as  $E$ ;  $\omega LI$  being the product of the total inductive reactance of both line wires and the line current.

The voltage necessary to counteract the self-induced voltage of the line  $\omega LI$  is drawn  $90^\circ$  ahead of the line current  $I$ ; since the voltage of self-induction is in time phase  $90^\circ$  behind the current  $I$  producing it. The voltage necessary to counteract the voltage of self-inductance is, in time phase,  $180^\circ$  from the voltage of self-induction, therefore, the voltage necessary to counteract the voltage of self-induction must be, in time phase,  $90^\circ$  ahead of  $I$ . By connecting the end of the line  $\omega LI$ , and the origin  $O$ , the resultant

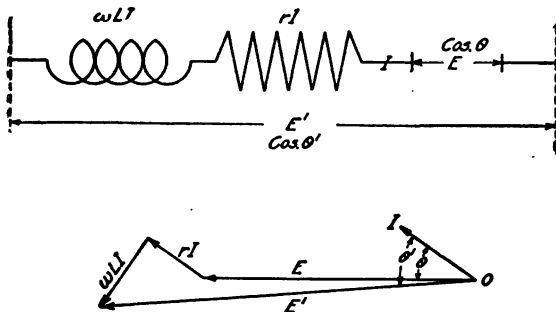

Fig. 291.—Single phase system

line  $E'$  represents the voltage at the generator to the scale of  $E$ . The angle between  $E'$  and  $I$ ,  $\theta'^\circ$ , is the angle of lag at the generator, and  $\cos. \theta'$  is the power factor at the generator.

24. **The Two-Phase Four-Wire System** is calculated as two separate single phase systems, since there is no inter-connection, and by properly locating the wires in reference to each other (Art. 61) mutual induction may be reduced to a negligible quantity. Fig. 292 illustrates the circuits that may replace the actual lines, using concentrated instead of distributed inductance and resistance, also the vector analysis of this problem. All values are obtained as in Fig. 291, and the vectors are marked with the subscript of the phase which they represent. Under balanced conditions, the angles and vector values are the same in both phases, therefore, the angle between the resultant voltages is the same as that between the initial voltage, *i.e.*,  $90^\circ$ , and there is no dephasing action.



25. In the Two-Phase Three-Wire System the relations are more complex since there is a common connection between phases which carries a current that lags in relation to one phase and leads in relation to the other, thus disturbing the angular relation of the

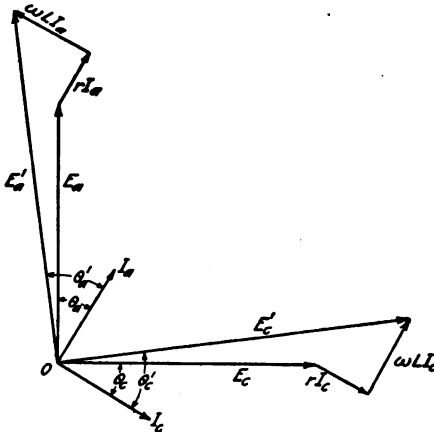
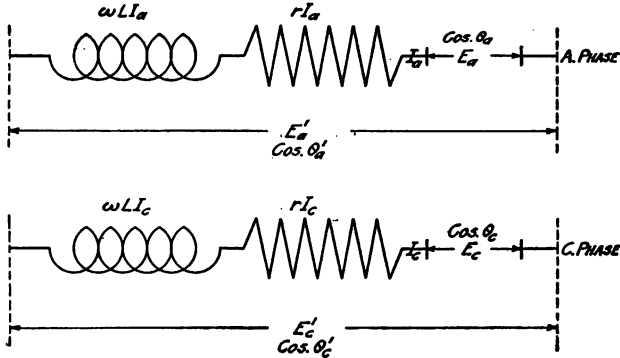

Fig. 292.—Two phase, four wire system.

resulting voltages. As the voltages at the generator have a fixed 90° relation, the solution is started by first considering conditions at the generator and working toward the resulting conditions at the receiver.

The accurate calculation of the voltage relations in a two-phase, three-wire system is difficult.

The value of the current or power-factor at the generator cannot be determined until the voltage at the receiver is found; and the voltage at the receiver cannot be determined until the line drop and dephasing angle are known.

Again, the line drop cannot be determined until the line current and powerfactor are known; therefore, the line drop cannot be determined until the voltage at the receiver is known.

Since the line drop and receiver voltage are both unknown, it is impossible to find either without first assuming one, making a trial solution for the other and so continuing until fairly accurate results are obtained.

By solving a two-phase, three-wire line as though it were a two-phase, four-wire line and neglecting the dephasing action of the common wire, a value of voltage drop will be obtained which is equal to the average of the accurate drops. The drop will generally be greater in the leading phase and less in the lagging phase.

The construction of the vector diagram is illustrated in Fig. 293, as follows.

Draw  $E'_a$  and  $E'_c$  to a scale proportional to the generator voltages and  $90^\circ$  apart. Draw  $I_a$  and  $I_c$  to a scale proportional to the load current and in phase relation  $\theta^\circ$  behind  $E'_a$  and  $E'_c$  where  $\cos \theta'$  is the powerfactor at the generator.

Draw  $I_b$ , the resultant of  $I_a$  and  $I_c$ .

Draw  $\omega LI_a$  and  $\omega LI_c$  to the same scale as  $E'_a$  and in phase  $90^\circ$  ahead of  $I_a$  and  $I_c$ . These vectors represent the voltage absorbed in the inductive reactance of the outside wires. Draw  $rI_a$  and  $rI_c$  to the same scale as  $E'_a$  and in phase with  $I_a$  and  $I_c$ . These vectors represent the voltages absorbed in the resistance of the outside wires, and are drawn from the ends of the reactance drop vectors,  $E_a$  and  $E_c$  being the unknown quantities; therefore, they must be omitted in the voltages given in the diagrammatic sketch of the line and the drop in the b or common wire must be next considered.

From O draw  $rI_b$  to the same scale as  $E'_a$  and in phase with  $I_b$ , the current in the common wire. This represents the voltage absorbed in the resistance of the common wire. Draw  $\omega LI_b$  to the same scale as  $E'_a$  and in phase  $90^\circ$  ahead of  $I_b$ . This represents the voltage absorbed in the inductive reactance of the b or common wire. If the line  $E_a$  is drawn from the end of the vector  $\omega LI_b$  to the end of the vector  $rI_a$ , the A voltage at the receiver is obtained both in value and phase; likewise the line joining the ends of the vector  $\omega LI_b$  and  $rI_c$  represents the phase relation and value of the C phase receiver voltage  $E_c$ .

**26. Three-Phase "Y" Connected System.** (Fig. 294.) Draw  $E_a$ ,  $E_b$  and  $E_c$  from the point O to a scale proportional to the receiver voltages and  $120^\circ$  apart. Draw  $I_a$ ,  $I_b$  and  $I_c$  from the point O to a scale proportional to the receiver current and  $\theta_a$ ,  $\theta_b$  and  $\theta_c$  degrees from their respective voltages;  $\theta_a$ ,  $\theta_b$  and  $\theta_c$  being

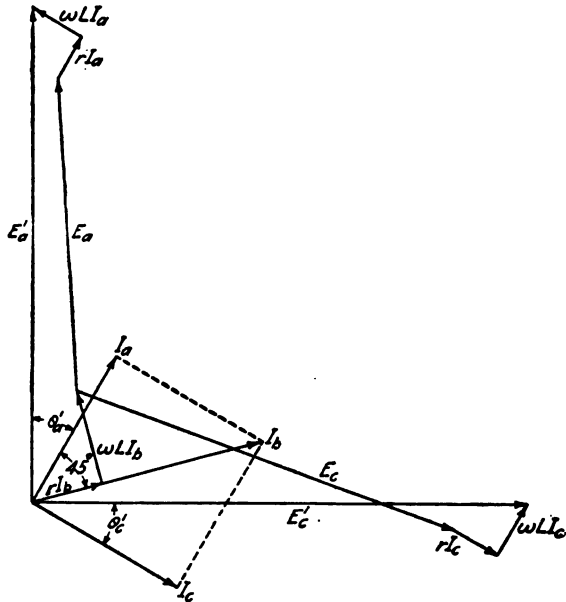
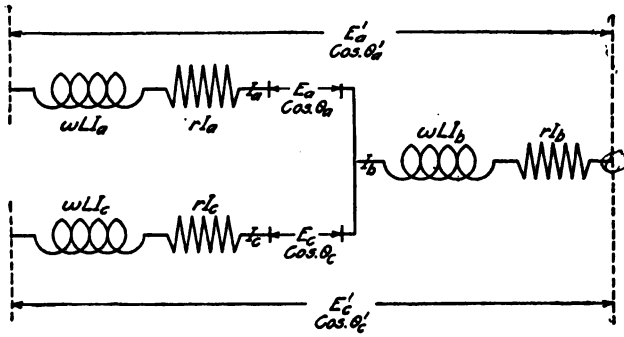

Fig. 293.—Two-phase, three-wire system.

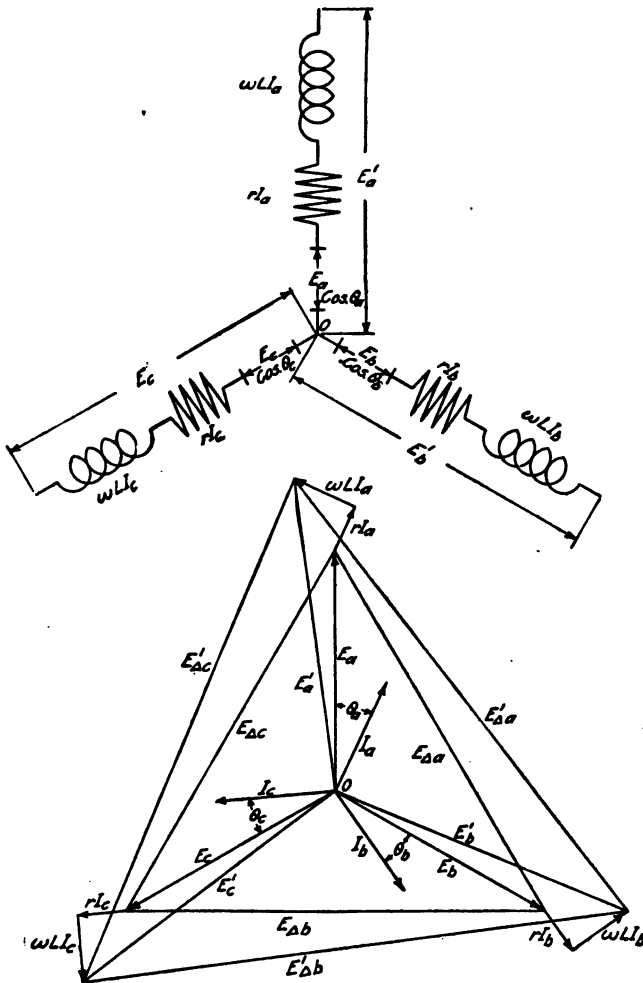

Fig. 294.—Three-phase system.

the angles, the cosines of which are equal to the power-factor of the circuit.

Draw  $rI_a$  parallel to  $I_a$  and to the same scale as the voltage  $E_a$ . Draw  $\omega LI_a$  90° ahead of  $I_a$  and to the same scale as  $E_a$ . The line connecting O and the end of  $\omega LI_a$  represents the voltage  $E'_a$  at the generator.  $E'_b$  and  $E'_c$  are found in the same manner. Lines connecting  $E'_a$ ,  $E'_b$  and  $E'_c$  represent the "Δ" voltages.

27. In the Three Phase "Δ" Connected System (Fig. 294), the line drop is the same as that in the "Y" connected system. If the "Δ" voltages  $E_{\Delta a}$ ,  $E_{\Delta b}$  and  $E_{\Delta c}$ , are given it is necessary to

find  $E_a$ ,  $E_b$ , etc., by the formula  $E_a = \frac{E_{\Delta a}}{\sqrt{3}}$ .

If the current in the single phase circuit of the "Δ" is known, then the line current  $I_a = I_{\Delta a}\sqrt{3}$ .

When these transformations have been made, the vector diagram, Fig. 294, also applies to the solution of a "Δ" connected system.

28. THE EFFECT OF CHARGING CURRENT ON LINE CALCULATIONS. Charging current has been neglected in the above solutions, in order to simplify the vector analysis.

All polyphase transmission lines may be solved as single phase lines, transmitting half the total amount of energy; (Sec. 7, Art. 36), therefore, in correcting for charging current the single phase system only will be considered. (Fig. 295.)

Draw  $E$  to a scale proportional to the receiver voltage. Draw the energy component of the current  $I$  parallel to  $E$  and to a scale proportional to the energy component of the load current; draw  $I_m$  in phase 90° behind  $E$  and equal to  $I \tan \theta$ , where  $\cos \theta$  equals the power-factor of the circuit.  $I_o$  is the total current at the receiver. Assume one half of the capacity of the transmission line concentrated at the receiver and one half at the generator.  $I_c$  equals the total charging current of the line at voltage  $E$ . Subtract  $\frac{1}{2}I_c$  from  $I_m$  and combine with  $I$ , which represents the total current corrected for charging current  $I_t$ .

Draw  $rI$  to a scale proportional to  $E$ , from the end of  $E$  and parallel to  $I$ . This represents the voltage absorbed, due to the energy component of the load current flowing through the total resistance of the line.

Draw  $\omega LI$  from the end of  $rI$  and in phase 90° ahead of  $I$ . This represents the voltage absorbed due to the energy component of the load current flowing through the line reactance.

From the end of  $\omega LI$  draw  $r(I_m - \frac{1}{2}I_c)$  parallel to  $I_m$ . This represents the voltage absorbed, due to the difference between the wattless component of the load current and one half of the charging current, flowing through the line resistance.

From the end of  $r(I_m - \frac{1}{2}I_c)$  and in phase 90° ahead of  $(I_m - \frac{1}{2}I_c)$  draw  $\omega L(I_m - \frac{1}{2}I_c)$ , which represents the voltage absorbed, due to the difference between the wattless component of the load current

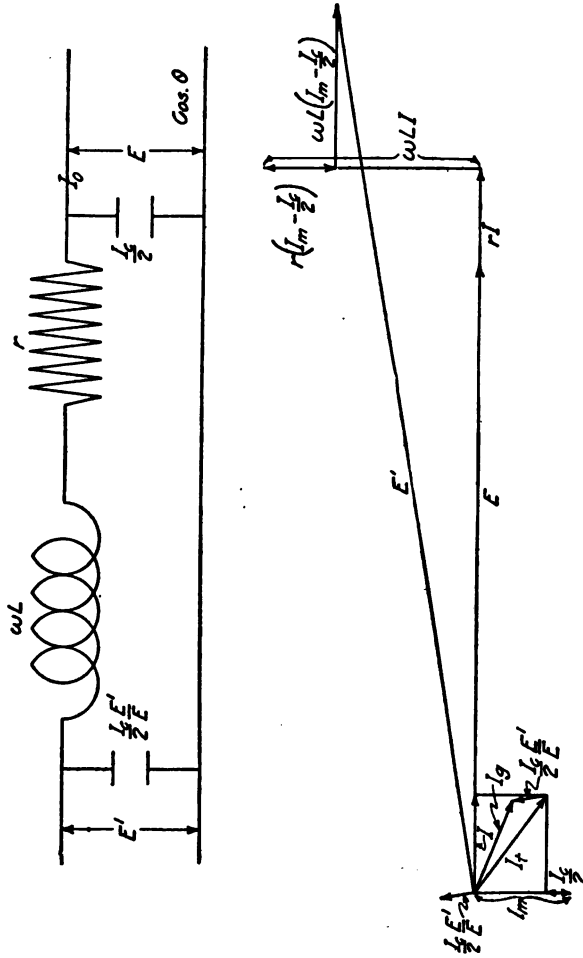

Fig. 295.—Charging current, vector diagram.

Sec. 7

ELECTRICAL CALCULATIONS

and one half of the charging current, flowing through the line reactance.

A line connecting the end of  $\omega L(I_m - \frac{1}{2}I_c)$  and the reference point represents the voltage  $E'$  at the generator. A line in phase  $90^\circ$  ahead of  $E'$  and equal to  $\frac{1}{2}I_c \frac{E'}{E}$  combined with  $I_t$  represents  $I_g$  the current at the generator.

The formulæ for solving the above diagram algebraically are as follows:

- $E$  = voltage at receiver.
- $E'$  = voltage at generator.
- $I$  = energy component of load current.
- $I_g$  = current at generator.
- $I_c$  = charging current of line at voltage  $E$ .
- $\cos. \theta^\circ$  = power-factor of load.
- $\cos. \theta_1^\circ$  = power-factor of generator.
- $\omega L$  = total reactance of line.
- $r$  = total resistance of line.

$$a = \frac{\omega L}{r} = \frac{x}{r}$$

$e'$  = ratio of voltage drop (due to the energy component of the current flowing through the line resistance) to  $E$ .

$$\tan \alpha = \frac{e'(a - \tan. \theta + \frac{I_c}{2I})}{1 + e' + e'a \tan. \theta - e'a \frac{I_c}{2I}}$$

$$E' = \frac{E(1 + e' + e'a \tan. \theta - e'a \frac{I_c}{2I})}{\cos. \alpha}$$

$$A = \left[ \sin. \alpha + \left( \tan. \theta - \frac{I_c}{2I} \right) \cos. \alpha - \frac{I_c}{2I} \frac{E'}{E} \right]$$

$$B = \left[ \cos. \alpha - \left( \tan. \theta - \frac{I_c}{2I} \right) \sin. \alpha \right]$$

$$\tan. \theta_1 = \frac{A}{B} \quad \cos. \theta_1 = \text{power-factor at generator}$$

$$I_g = \frac{I B}{\cos. \theta_1}$$

These formulæ are accurate for concentrated inductance, resistance, and capacity, but are incorrect for distributed inductance, resistance and capacity.

When the ratio of the charging current of the line to the energy component of the load current is less than 0.05 the charging current may be neglected. For overhead lines in length up to 60 miles at 25 cycles and 50 miles at 60 cycles, for potentials not exceed-

## ELECTRICAL CALCULATIONS

Sec. 7

ing 55,000 volts delivered, the error introduced by neglecting the condenser effect of the line is usually unimportant. Accurate formulae may be found in the references made a part of this section.

The increase in voltage at no load due to the charging current of the line flowing through the reactance may be found by using the following formula.

- e = voltage rise in per cent.
- l = length of line in miles.
- f = frequency in cycles per second.

$$e = \frac{57 l^2 f^2}{10^6}$$

### 29. FORMULAE FOR INDUCTANCE OF NON-MAGNETIC WIRES.

Symbols:

- d = distance between wires in inches.
- r = radius of conductor in inches.
- h = distance between wire and ground, in feet.
- L = inductance in millihenries.
- f = frequency in cycles per second.
- x = reactance in ohms.

Inductance of Single Conductor When Using the Ground as a Return Circuit.

$$L = 0.1408 \left( \log_{10} \frac{24h}{r} \right) + 0.0152 \text{ millihenries per 1000 feet of conductor.}$$

$$x = \frac{2 \pi f L}{10^6} \text{ ohms per 1000 feet of line.}$$

Inductance of Two Parallel Line Wires.

$$L = 0.2816 \left( \log_{10} \frac{d}{r} \right) + 0.0305 \text{ millihenries per 1000 feet of line (2000 ft. of wire.)}$$

$$x = \frac{2 \pi f L}{10^6} \text{ ohms per 1000 feet of line.}$$

### 30. FORMULAE FOR CAPACITY.

Symbols:

- r = radius of wire in inches.
- d = distances between wires in inches.
- h = height of wire above ground in feet.
- C = capacity of wires in microfarads.
- I<sub>c</sub> = charging current in amperes.



$f$  = frequency in cycles per second.

$E$  = effective voltage between lines or voltage between line and ground.

#### Capacity of One Conductor to Ground.

$$C = \frac{0.007353}{\log_{10} \frac{24h}{r}} \text{ microfarads per 1000 ft. of conductor.}$$

$$I_c = \frac{2 \pi f C E}{10^6} \text{ in amperes per 1000 ft. of line wire.}$$

$E$  = voltage between wire and ground.

#### Capacity Between Two Parallel Conductors.

$$C = \frac{0.003677}{\log_{10} \frac{d}{r}} \text{ microfarads per 1000 ft. of line (2000 ft. of conductor).}$$

$$I_c = \frac{2 \pi f C E}{10^6} \text{ amperes per 1000 ft. of line.}$$

$E$  = voltage between wires.

### 31. METHODS OF CALCULATING TRANSMISSION LOSSES.

The calculations of practical transmission problems may be divided into three general classes:

(a) Load, length of line, voltage, and size of wire given. Find voltage drop and power loss.

(b) Load, voltage, length of line, and per cent voltage drop or power loss given. Find size of wire required.

(c) Size wire, voltage, length of line and per cent voltage drop or power loss given. Find possible load.

### 32. Direct Current Two-Wire System.

Symbols:

$r$  = resistance in ohms per 1000 ft. of wire.

$l$  = length of line in feet.

$W$  = load in kilowatts.

$E$  = voltage between wires at load.

$e$  = per cent voltage drop.

$p$  = per cent power loss.

$I$  = load current.

Formulae:

$$I = \frac{W \times 1000}{E}$$

$$e = p = \frac{2 r l I}{10 E}$$

**(I) Problem.**

Determine the percentage power loss and voltage drop when 100 kilowatts are transmitted a distance of 1000 feet at 220 volts using 500,000 cir. mils copper cable with weatherproof insulation.

$$r \text{ from Sec. 3} = 0.02116.$$

$$I = \frac{100 \times 1000}{220} = 454 \text{ amperes.}$$

$$p = e = \frac{2 \times 0.02116 \times 1000 \times 454}{10 \times 220} = 8.74\%.$$

$$\text{Volts drop} = \frac{eE}{100} = \frac{8.74 \times 220}{100} = 19.21 \text{ volts.}$$

$$\text{Power loss} = \frac{pW}{100} = \frac{8.74 \times 100}{100} = 8.74 \text{ kilowatts.}$$

The current, 454 amperes, is within the specified current carrying capacity of 500,000 cir. mil. Triple Braid Weatherproof Copper Wire.

**(II) Problem:**

Determine the size copper conductor necessary to transmit 100 kilowatts a distance of 500 feet at 220 volts, allowing 5% voltage drop.

**Formulae:**

$$I = \frac{W \times 1000}{E}$$

$$r = \frac{e E 10}{2 I} = \frac{p E 10}{2 I}$$

$$I = \frac{100 \times 1000}{220} = 454 \text{ amperes.}$$

$$r = \frac{5 \times 220 \times 10}{2 \times 500 \times 454} = 0.0242 \text{ ohm.}$$

From Sec. 3 the size copper wire having a resistance of 0.0242 ohm per 1000 ft. will be found to be 450,000 cir. mils (nearest size). The current, 454 amperes, is within the specified current carrying capacity of 450,000 cir. mils. Triple Braid Weatherproof Copper Wire.

**(III) Problem:**

Determine the power that can be transmitted a distance of 500 feet at 220 volts, using 0000 solid copper wire. Assume a power loss of 10%.

## Sec. 7 ELECTRICAL CALCULATIONS

Formulae:

$$I = \frac{e E 10}{2 r l} = \frac{p E 10}{2 r l}$$

$$W = \frac{E I}{1000}$$

From Table 35 in Sec. 3, find  $r = 0.04893$ .

$$I = \frac{10 \times 220 \times 10}{2 \times 0.04893 \times 500} = 450 \text{ amperes.}$$

This exceeds the current carrying capacity of No. 0000 Triple Braid Weatherproof wire, which is 325 amperes. Therefore the maximum load that can be transmitted is:

$$W = \frac{325 \times 220}{1000} = 71.5 \text{ kilowatts.}$$

**33. Two-Wire Direct Current Railway System.** These calculations are the same as for the two-wire Direct Current System when there is a negative and positive feeder from the station to the load. When connections are made as in Fig. 296, the resistance of the trolley wire and rails must also be considered.

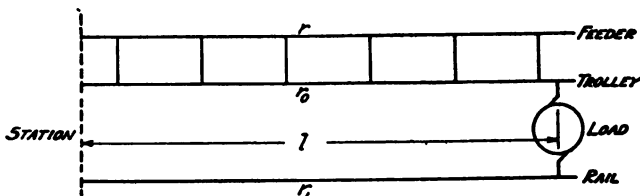

Fig. 296.

Symbols:

- $r_0$  = resistance in ohms per 1000 ft. of trolley wire.
- $r$  = resistance in ohms per 1000 ft. of feeder wire.
- $r_1$  = resistance in ohms per 1000 ft. of rails and bonds.
- $l$  = length of line in feet.
- $W$  = load in kilowatts.
- $E$  = voltage between trolley wire and rails at load. ]
- $e$  = per cent voltage drop.
- $p$  = per cent power loss.
- $I$  = load current.
- $I_0$  = current carried by feeder.

(I) Problem:

Determine the per cent power loss, in transmitting 90 kilowatts a distance of 5000 feet at 600 volts, assuming a 250,000 cir. mils cop-

per Triple Braid Weatherproof feeder cable, a No. 0000 copper trolley wire, a single track, composed of 80 lb. rails bonded with 2-20' No. 0000 copper rail bonds.

Formulae:

$$R = \frac{r r_0}{r + r_0} + r_1 = \text{total resistance per 1000 ft. of line.}$$

$$I = \frac{W \times 1000}{E}$$

$$e = p = \frac{R I}{10 E}$$

$$I_0 = \frac{(R - r_1) I}{r}$$

See Sec. 3 for resistances.

$$r = 0.04233 \text{ ohm, } r_0 = 0.04893 \text{ ohm, } r_1 = 0.007746 \text{ ohm.}$$

$$R = \frac{0.04233 \times 0.04893}{0.04233 + 0.04893} + 0.007746 = 0.030376 \text{ ohm.}$$

$$I = \frac{90 \times 1000}{600} = 150 \text{ amperes.}$$

$$p = \frac{0.030376 \times 5000 \times 150}{10 \times 600} = 3.8\%.$$

$$I_0 = \frac{0.030376 - 0.007746}{0.04233} \times 150 = 80.4 \text{ amperes.}$$

This current is very much below the allowable current carrying capacity of the conductors considered.

(II) Problem:

Determine the size feeder necessary to transmit 90 kilowatts 10,000 feet at 600 volts, assuming No. 0000 copper trolley wire, a single track of 80 lb. rails, bonded with 2-20' No. 0000 copper bonds. The voltage loss assumed to be 10%.

Formulae:

$$I = \frac{W \times 1000}{E}$$

$$R = \frac{p E 10}{I} = \frac{e E 10}{I}$$

$$r = \frac{(R - r_1) r_0}{r_0 + r_1 - R}$$

$$I_0 = \frac{r_0}{r_0 + r} I$$

## Sec. 7 ELECTRICAL CALCULATIONS

$$e = 10\%$$

$$I = \frac{90 \times 1000}{600} = 150 \text{ amperes.}$$

$$R = \frac{10 \times 600 \times 10}{10,000 \times 150} = 0.04 \text{ ohms.}$$

$$r = \frac{(0.04 - 0.007746) 0.04893}{0.04893 + 0.007746 - 0.04} = 0.0945.$$

Size feeder from Sec. 3 is No. 0 solid.

$$I_0 = \frac{0.04893}{0.04893 + 0.09811} \times 150 = 50 \text{ amperes.}$$

### (III) Problem:

A railway has been transmitting 50 kilowatts at 600 volts over a 300,000 cir. mil. copper feeder connected to a No. 0000 copper trolley wire. The distance of transmission is 20,000 ft. The single track consists of 80 lb. rails, bonded with 2-20" No. 0000 copper bonds. Find the energy that can be transmitted at 1,200 volts, allowing 10% power loss.

$$R = \frac{r r_0}{r + r_0} + r_1$$

$$I = \frac{e E 10}{R l} = \frac{p E 10}{R l}$$

$$I_0 = \frac{(R - r_1)}{r} I$$

$$W = \frac{E I}{1000}$$

See Sec. 3 for resistances.

$$r = 0.03531 \text{ ohm, } r_0 = 0.04893 \text{ ohm, } r_1 = 0.007746 \text{ ohm.}$$

$$R = \frac{0.03531 \times 0.04893}{0.03531 + 0.04893} + 0.007746 = 0.028226 \text{ ohm.}$$

$$I = \frac{10 \times 1200 \times 10}{0.028226 \times 20,000} = 212.2 \text{ amperes.}$$

$$I_0 = \frac{.028226 - 0.007746}{0.03531} \times 212.2 = 123.2 \text{ amperes.}$$

The value is well within the carrying capacity of the cable.

$$W = \frac{1,200 \times 212.2}{1,000} = 255 \text{ kilowatts.}$$

The more complex problems covering net-works will not be given. A general solution for such problems is of little value because of the multiplicity of variable conditions prevailing.

**34. The Edison Three-Wire System.** The calculation for feeders in this system is similar to that of the two-wire system. The voltage used is that between the two outside wires and not the voltage between the outside and neutral wire. Two wire taps from a three-wire system are also calculated in the same manner. The voltage used depending upon whether the tap is made between the outside and neutral or between the two outside wires. In the former case the voltage between the outside and neutral wire, and in the latter the voltage between the outside wires is used.

### 35. Direct Current Series System.

#### Symbols:

- $r$  = resistance in ohms per 1000 feet of wire.
- $I$  = current of lamps.
- $E$  = voltage of lamps.
- $E'$  = machine voltage.
- $l$  = length of line in feet.
- $N$  = number of lamps.

#### Problem:

Find the voltage at the generator when No. 6 copper wire is used to transmit energy for 50—4 ampere lamps, each consuming 80 volts; the total length of line being 20,000 feet.

#### Formulae:

$$E' = \frac{r l I}{1000} + NE$$

The resistance of No. 6 copper wire = 0.3944 ohm. (See Sec. No. 3.)

$$E' = \frac{0.3944 \times 20,000 \times 4}{1,000} + (50 \times 80)$$

$$E' = 4,031.55 \text{ volts.}$$

It will be noted that the voltage drop is such a small part of the total voltage that the calculation depends upon the number of lamps, rather than the length of the line. A line 40,000 ft. long will have a voltage drop of  $31.55 \times 2 = 63.10$  volts = 1.55% drop.

**36. CALCULATION OF ALTERNATING CURRENT SYSTEMS.** Before making any calculation the relations that the various systems bear to each other should be known. The following short discussion is based upon an equal size wire in each leg of the transmission line and an equal voltage between phase wires:

- $I_0$  = load current.
- $r$  = resistance of one wire.
- $W$  = power transmitted in watts.

## Sec. 7

## ELECTRICAL CALCULATIONS

$E$  = effective voltage between wires.

$\cos. \theta$  = power-factor of load.

$p$  = ratio of power loss to power delivered.

Determine the per cent power loss for, single-phase, two-phase four-wire; two-phase three-wire, and three-phase three-wire systems.

**Single-phase:**

$$I_0 = \frac{W}{E \cos. \theta}$$

$$I_0^2 = \frac{W^2}{E^2 \cos.^2 \theta}$$

Power loss in one wire is

$$rI_0^2 = \frac{rW^2}{E^2 \cos.^2 \theta}$$

Total power loss is

$$2 rI_0^2 = \frac{2 r W^2}{E^2 \cos.^2 \theta}$$

The ratio of power loss ( $p$ ) to load is

$$p = \frac{2 r I_0^2}{W} = \frac{2 r W^2}{W E^2 \cos.^2 \theta}$$

$$p = \frac{2 r W}{E^2 \cos.^2 \theta}$$

**Two-phase, four-wire:**

$$I_0 = \frac{W}{2 E \cos. \theta}$$

$$I_0^2 = \frac{W^2}{4 E^2 \cos.^2 \theta}$$

Loss in one wire

$$rI_0^2 = \frac{r W^2}{4 E^2 \cos.^2 \theta}$$

Loss in four wires

$$4 rI_0^2 = \frac{4 r W^2}{4 E^2 \cos.^2 \theta} = \frac{r W^2}{E^2 \cos.^2 \theta}$$

$$p = \frac{4 r I_0^2}{W} = \frac{r W^2}{W E^2 \cos.^2 \theta} = \frac{r W}{E^2 \cos.^2 \theta}$$

Two-phase, three-wire:

$$I_a = \frac{W}{2 E \cos. \theta}$$

$$I_a^2 = \frac{W^2}{4 E^2 \cos.^2 \theta}$$

$$I_b = I_a \sqrt{2}$$

$$I_b^2 = 2 I_a^2 = \frac{2 W^2}{4 E^2 \cos.^2 \theta} = \frac{W^2}{2 E^2 \cos.^2 \theta}$$

Total loss

$$rI_a^2 + rI_b^2 + rI_c^2 = \frac{r W^2}{4 E^2 \cos.^2 \theta} + \frac{r W^2}{2 E^2 \cos.^2 \theta} + \frac{r W^2}{4 E^2 \cos.^2 \theta} = \frac{r W^2}{E^2 \cos.^2 \theta}$$

$$p = \frac{\text{Total loss}}{W} = \frac{r W^2}{W E^2 \cos.^2 \theta} = \frac{r W}{E^2 \cos.^2 \theta}$$

Three-phase, three-wire:

$$I_o = \frac{W}{\sqrt{3} E \cos. \theta}$$

$$I_o^2 = \frac{W^2}{3 E^2 \cos.^2 \theta}$$

Loss in one wire

$$rI_o^2 = \frac{r W^2}{3 E^2 \cos.^2 \theta}$$

Loss in three wires.

$$3 r I_o^2 = \frac{3 r W^2}{3 E^2 \cos.^2 \theta}$$

$$p = \frac{3 r I_o^2}{W} = \frac{r W^2}{W E^2 \cos.^2 \theta} = \frac{r W}{E^2 \cos.^2 \theta}$$

Summary:

$$\text{Single-phase} \quad p = \frac{2 r W}{E^2 \cos.^2 \theta}$$

$$\text{Two-phase, 4-wire} \quad p = \frac{r W}{E^2 \cos.^2 \theta}$$

$$\text{Two-phase, 3-wire} \quad p = \frac{r W}{E^2 \cos.^2 \theta}$$

$$\text{Three-phase, 3-wire} \quad p = \frac{r W}{E^2 \cos.^2 \theta}$$

Thus it follows, that with the same size wires and equal voltage between wires, the per cent power loss is the same in the two-phase four-wire; two-phase three-wire; and three-phase three-wire



systems, and in all these systems it is only one-half of that of a single-phase system.

Therefore, by considering one-half the load and solving as a single-phase two-wire line, the correct results will be obtained for each of the three systems mentioned. This also holds true for per cent voltage drop, with the exception of the two-phase three-wire system, in which the average voltage and not the actual voltage drop will be obtained because of the dephasing action of the common wire.

### 37. EXPLANATION OF THE LINE LOSS TABLES.

Symbols:

$r$  = resistance in ohms per 1,000 ft. of wire.

$\frac{x}{r}$  = ratio of reactance to resistance.

$l$  = length of the line in feet.

$W$  = load in kw.

$E$  = voltage between wires at the receiving end of the line.

$p$  = power loss in per cent of energy at the receiving end of the line.

$e$  = total voltage drop in per cent of the receiver voltage.

$e'$  = voltage drop due to the energy component of the load current flowing through the line resistance, in per cent of the receiver voltage.

$I$  = energy component of the load current.

$I_0$  = total load current.

$I_c$  = total charging current of the line at voltage  $E$ .

$a$  = voltage drop factor, Table 61, Sec. 7.

$b$  = power loss factor, Table 59, Sec. 7.

$q$  = ratio of the total current to the energy component of the current, Table 62, Sec. 7.

Formulae:

Single phase:

$$I = \frac{W \times 1000}{E}$$

$$e' = \frac{2 r l I}{10 E}$$

$$e = e' a$$

$$p = e' b$$

$$I_0 = q I$$

Polyphase:

$$I = \frac{W \times 1000}{2 E}$$

$$e' = \frac{2 r l I}{10 E}$$

$$\begin{aligned} e &= e' a \\ p &= e' b \\ I_0 &= q I \end{aligned}$$

The charging current of the line,  $I_c$  is found by obtaining the value of  $I_{cc}$  from the Tables in Sec. 3, for the proper size of conductor and the separation of the conductors in feet; per thousand feet of line, per thousand volts between wires.

Then

$$I_c = \frac{I_{cc} E l}{10^3}$$

The energy component of the current  $I$  and the per cent voltage drop due to this energy component of the current flowing through the line resistance, may be found from the formula given above.

Divide  $I_c$  by  $I$ . Apply this ratio to Table 59 in conjunction with the power-factor of the load, and find the value of  $b$ .

Multiply  $e'$  by  $b$ , securing the power loss in per cent.

To find the correct power-factor at the receiving end of the line, apply the power loss factor  $b$  to the Power-factor, Conversion Table 60, Sec. 7. This power-factor is used in conjunction with Table 61, Sec. 7, to calculate the a-c. voltage drop. Find the ratio of the inductive reactance to ohmic resistance  $\frac{X}{r}$  for the size, spacing and material of the conductor from the reactance and resistance tables in Sec. 3.

With this value of  $\frac{X}{r}$  and the corrected power-factor, find values of  $a$  from Table 61, Sec. 7. These values multiplied by  $e'$  will give the per cent voltage drop. To find the generator power-factor, divide  $(100+p)$  by  $(100+e)$ ; and multiply by the corrected power-factor. This will give the uncorrected power-factor at the generator end. Multiply  $\frac{I_c}{I}$  by  $(100+e)^2$ , divided by  $(100+p)$ , thus obtaining the corrected values for ratio of charging current to the energy component of the current. Apply these values to Table 59 as before, and the resultant value of  $b$  when applied to Table 60 will give the correct power-factor at the generating end of the line. The formulae for this are as follows:

$$\begin{aligned} \cos. \theta_g &= \cos. \theta_l \frac{(100+p)}{(100+e)} \\ \frac{I_c'}{I} &= \frac{I_c}{I} \times \frac{(100+e)^2}{(100+p)} \end{aligned}$$

The values in Table 62 for the power-factor and for the various systems give a constant  $q$  by which the energy component  $I$  may be multiplied, obtaining the actual load current flowing in the wire.

NOTE: All tables in this section may be interpolated in a manner similar to that used in the interpolation of logarithmic tables.

**TABLE 59**  
**POWER LOSS, VALUES OF "b"**

P.F.	$\frac{I_c}{I_L}$										
	0.0	0.1	0.2	0.3	0.4	0.5	0.6	0.7	0.8	0.9	1.0
.40	6.25	6.02	5.80	5.59	5.37	5.17	4.97	4.77	4.58	4.39	4.21
.45	4.94	4.74	4.55	4.37	4.19	4.01	3.84	3.67	3.51	3.36	3.20
.50	4.00	3.83	3.66	3.50	3.35	3.20	3.05	2.91	2.77	2.64	2.52
.55	3.31	3.16	3.01	2.87	2.74	2.61	2.49	2.37	2.25	2.14	2.04
.60	2.78	2.65	2.52	2.40	2.28	2.17	2.07	1.97	1.87	1.78	1.69
.65	2.37	2.25	2.14	2.04	1.94	1.85	1.76	1.67	1.59	1.52	1.45
.70	2.04	1.94	1.85	1.76	1.67	1.59	1.52	1.45	1.39	1.33	1.27
.75	1.78	1.69	1.61	1.54	1.47	1.40	1.34	1.28	1.23	1.19	1.15
.80	1.56	1.49	1.42	1.36	1.30	1.25	1.20	1.16	1.12	1.09	1.06
.85	1.38	1.33	1.27	1.22	1.18	1.14	1.10	1.07	1.05	1.03	1.01
.90	1.23	1.19	1.15	1.11	1.08	1.06	1.03	1.02	1.01	1.00	1.00
.95	1.11	1.08	1.05	1.03	1.02	1.01	1.00	1.00	1.00	1.01	1.03
.98	1.04	1.02	1.01	1.00	1.00	1.00	1.01	1.02	1.04	1.06	1.09
.99	1.02	1.01	1.00	1.00	1.00	1.01	1.03	1.04	1.07	1.10	1.13
1.00	1.00	1.00	1.01	1.02	1.04	1.06	1.09	1.12	1.16	1.20	1.25
.99	1.02	1.04	1.06	1.09	1.12	1.15	1.20	1.24	1.29	1.35	1.41
.98	1.04	1.06	1.09	1.13	1.16	1.21	1.25	1.31	1.36	1.43	1.49
.95	1.11	1.14	1.18	1.23	1.28	1.33	1.39	1.46	1.53	1.61	1.69
.90	1.23	1.29	1.34	1.40	1.47	1.54	1.62	1.70	1.78	1.87	1.97
.85	1.38	1.45	1.52	1.59	1.67	1.76	1.85	1.94	2.04	2.14	2.25
.80	1.56	1.64	1.72	1.81	1.90	2.00	2.10	2.21	2.32	2.44	2.56
.75	1.78	1.87	1.96	2.07	2.17	2.28	2.40	2.52	2.64	2.77	2.91
.70	2.04	2.15	2.26	2.37	2.49	2.61	2.74	2.88	3.02	3.16	3.41

NOTE: Values below heavy lines are for leading power-factors.

### 38. Single-Phase Two-Wire System.

#### Problem:

Find the power loss in kw. and the voltage drop in volts, when transmitting 50 kw. at 220 volts, 80% power-factor, on a single phase 60 cycle line 200 feet long, using No. 0000 stranded copper T. B. W. wire, spacing between wires 12 inches.

$$I = \frac{50 \times 1000}{220} = 227 \text{ amperes.}$$

From Table 36, Sec. 3,  $r = 0.04997$ .

$$e' = \frac{2 \times 0.04997 \times 200 \times 227}{10 \times 220} = 2.06$$

**TABLE 60**  
**CONVERSION TABLE**

To find power-factor from power loss table.

P.F.	b	P.F.	b	P.F.	b	P.F.	b
1.00	1.000	0.80	1.562	0.60	2.700	0.40	6.250
0.99	1.020	0.79	1.602	0.59	2.872	..	..
0.98	1.041	0.78	1.643	0.58	2.972	..	..
0.97	1.063	0.77	1.686	0.57	3.077	..	..
0.96	1.085	0.76	1.731	0.56	3.187	..	..
0.95	1.108	0.75	1.777	0.55	3.305	..	..
0.94	1.131	0.74	1.826	0.54	3.429	..	..
0.93	1.156	0.73	1.876	0.53	3.557	..	..
0.92	1.181	0.72	1.929	0.52	3.688	..	..
0.91	1.207	0.71	1.977	0.51	3.844	..	..
0.90	1.234	0.70	2.041	0.50	4.000	..	..
0.89	1.262	0.69	2.100	0.49	4.164	..	..
0.88	1.291	0.68	2.162	0.48	4.340	..	..
0.87	1.321	0.67	2.227	0.47	4.526	..	..
0.86	1.352	0.66	2.296	0.46	4.725	..	..
0.85	1.384	0.65	2.367	0.45	4.939	..	..
0.84	1.417	0.64	2.441	0.44	5.165	..	..
0.83	1.450	0.63	2.512	0.43	5.408	..	..
0.82	1.487	0.62	2.601	0.42	5.668	..	..
0.81	1.524	0.61	2.687	0.41	5.948	..	..

From Table 45, Sec. 3,  $x$ , for 60 cycles = 0.0953

$$\frac{x}{r} = \frac{0.0953}{0.04997} = 1.91$$

From Table 61, Sec. 7—for  $\frac{x}{r} = 1.91$  and 80% power-factor, find  $a = 2.487$

From Table 59, Sec. 7—for  $\frac{I_c}{I} = 0.0$  and 80% power-factor, find  $b = 1.56$

From Table 62, Sec. 7—for single phase and 80% power-factor find  $q = 1.25$

$$e = 2.06 \times 2.487 = 5.125\%$$

$$p = 2.06 \times 1.56 = 3.21\%$$

$$I_0 = 1.25 \times 227 = 284 \text{ amperes.}$$

$I_0$  is within the current carrying capacity of the No. 0000 stranded copper T. B. W. wire.

$$\text{Volts drop} = \frac{5.125 \times 220}{100} = 11.28 \text{ volts.}$$

$$\text{Power loss} = \frac{3.21 \times 50}{100} = 1.605 \text{ kw.}$$

TABLE 61

X	r	Values of "g" for power-factors of										Values of "g" for power-factors of																																
		1.00					.95					.90					.85					.80					.70					.60					.40					.20		
Form 3		Section 3		Form 3		Section 3		Form 3		Section 3		Form 3		Section 3		Form 3		Section 3		Form 3		Section 3		Form 3		Section 3		Form 3		Section 3		Form 3		Section 3										
1	1.00	1.03	1.06	1.08	1.09	1.14	1.17	1.33	1.50	2.5	1.27	2.00	2.33	2.68	2.97	3.60	4.34	6.78	13.35																									
2	1.00	1.08	1.12	1.14	1.16	1.23	1.30	1.57	2.00	2.6	1.30	2.05	2.45	2.75	3.05	3.71	4.45	7.00	13.90																									
3	1.00	1.11	1.17	1.20	1.24	1.33	1.43	1.83	2.50	2.7	1.32	2.10	2.51	2.84	3.14	3.83	4.56	7.45	14.50																									
4	1.00	1.14	1.22	1.27	1.32	1.43	1.55	2.05	3.00	2.8	1.35	2.16	2.58	2.90	3.21	3.94	4.70	7.68	14.75																									
5	1.00	1.17	1.27	1.33	1.38	1.53	1.68	2.30	3.50	2.9	1.37	2.21	2.66	2.99	3.30	4.05	4.85	7.88	15.25																									
6	1.01	1.21	1.31	1.40	1.44	1.63	1.82	2.52	4.00	3.0	1.40	2.26	2.73	3.06	3.40	4.15	5.00	8.07	15.75																									
7	1.02	1.24	1.37	1.46	1.51	1.71	1.95	2.78	4.55	3.1	1.42	2.32	2.80	3.13	3.50	4.25	5.16	8.27	16.25																									
8	1.02	1.27	1.42	1.52	1.60	1.81	2.07	3.00	5.05	3.2	1.45	2.38	2.86	3.21	3.59	4.35	5.34	8.47	16.75																									
9	1.03	1.32	1.48	1.58	1.68	1.93	2.20	3.22	5.50	3.3	1.48	2.43	2.92	3.30	3.66	4.45	5.50	8.67	17.25																									
10	1.04	1.35	1.52	1.64	1.75	2.02	2.32	3.45	6.00	3.4	1.51	2.49	2.99	3.38	3.75	4.56	5.65	8.90	17.70																									
11	1.05	1.39	1.57	1.70	1.81	2.12	2.45	3.65	6.50	3.5	1.53	2.55	3.05	3.45	3.85	4.66	5.80	9.12	18.15																									
12	1.06	1.42	1.62	1.77	1.89	2.22	2.57	3.88	7.00	3.6	1.57	2.60	3.12	3.53	3.94	4.78	5.94	9.30	18.60																									
13	1.07	1.46	1.65	1.82	1.96	2.32	2.73	4.10	7.45	3.7	1.60	2.65	3.18	3.62	4.04	4.90	6.08	9.52	19.10																									
14	1.08	1.51	1.72	1.90	2.05	2.43	2.85	4.30	7.98	3.8	1.64	2.71	3.23	3.68	4.12	5.05	6.20	9.73	19.60																									
15	1.10	1.55	1.78	1.96	2.13	2.53	3.00	4.52	8.50	3.9	1.67	2.77	3.30	3.77	4.22	5.18	6.34	9.94	20.10																									
16	1.10	1.59	1.84	2.05	2.21	2.64	3.12	4.75	9.00	4.0	1.70	2.82	3.37	3.85	4.32	5.30	6.49	10.20	20.60																									
17	1.13	1.63	1.89	2.10	2.30	2.74	3.25	4.97	9.50	4.1	1.73	2.88	3.42	3.93	4.40	5.41	6.64	10.45	21.10																									
18	1.15	1.68	1.96	2.18	2.39	2.84	3.40	5.20	9.95	4.2	1.78	2.95	3.47	4.01	4.50	5.54	6.76	10.65	21.60																									
19	1.17	1.72	2.02	2.25	2.48	2.94	3.52	5.40	10.40	4.3	1.81	3.01	3.58	4.10	4.59	5.65	6.91	10.90	22.10																									
20	1.18	1.77	2.08	2.33	2.55	3.06	3.65	5.62	10.90	4.4	1.84	3.06	3.66	4.18	4.68	5.78	7.05	11.10	22.60																									
21	1.20	1.81	2.14	2.39	2.62	3.16	3.80	5.88	11.40	4.5	1.88	3.12	3.72	4.26	4.78	5.89	7.20	11.40	23.10																									
22	1.22	1.86	2.20	2.46	2.71	3.27	3.95	6.13	11.90	4.6	1.91	3.19	3.80	4.34	4.88	6.00	7.35	11.60	23.60																									
23	1.23	1.92	2.26	2.53	2.79	3.38	4.08	6.33	12.40	4.7	1.96	3.26	3.91	4.42	4.98	6.12	7.50	11.80	24.00																									
24	1.25	1.97	2.32	2.61	2.88	3.49	4.22	6.55	12.90	..	..	..	..	..	..	..	..	..	..																									

**TABLE 62**  
**VALUES OF q**

P. F.	Single Phase	2-Phase 4-Wires	2-PHASE, 3-WIRE		3-Phase
			Outer Wires	Common Wire	
.95	1.052	1.052	1.052	1.488	1.215
.90	1.111	1.111	1.111	1.571	1.282
.85	1.176	1.176	1.176	1.667	1.357
.80	1.250	1.250	1.250	1.768	1.443
.70	1.429	1.429	1.429	2.02	1.649
.60	1.667	1.667	1.667	2.357	1.923
.40	2.50	2.50	2.50	3.535	2.885
.20	5.00	5.00	5.00	7.07	5.77

39. Single-Phase Three-Wire Systems are calculated in a manner similar to that for the single-phase 2-wire circuit, using the voltage between the outside wires for the value of E.

#### 40. Two-Phase Three-Wire Systems.

##### Problem:

How far, and with what average voltage drop can 500 kw. at 2,200 volts, 60 cycles, and 85% power-factor be transmitted on a two-phase, three-wire system, using No. 00 stranded copper wire, spaced 12 inches from center to center, assuming a 10% power loss.

In Table 45, Sec. 3, for 60 cycles and 12" spacing find  $x = 0.1006$ .

In Table 36, Sec. 3, find  $r = 0.07935$ .

$$\frac{x}{r} = \frac{0.1006}{0.07935} = 1.268$$

Table 61, Sec. 7 for  $\frac{x}{r} = 1.268$  and power-factor of 85%  $a = 1.804$ .

Table 59, Sec. 7 for  $\frac{I_c}{I} = 0.0$  and power-factor of 85%,  $b = 1.38$ .

$$p = 10$$

$$e' = \frac{10}{1.38} = 7.25\%$$

Per cent volts drop  $e = 7.25 \times 1.804 = 13.1\%$ .

$$I = \frac{W \times 1000}{2 E}$$

$$l = \frac{e' 10 E}{2 r I}$$

$$I = \frac{500 \times 1000}{2 \times 2200} = 113.5 \text{ amperes.}$$

$$l = \frac{7.25 \times 10 \times 2200}{2 \times 0.07935 \times 113.5} = 8,860 \text{ feet.}$$

The power loss calculations are correct, but the voltage drop calculations give the **average** drop on each phase. The leading phase will have the greatest drop. See Art. 25, Sec. 7.

See Table 62, Sec. 7.

$$q = 1.667.$$

$$I_0 = 113.5 \times 1.667 = 189.4 \text{ amperes in the common wire.}$$

This is within the allowable carrying capacity of No. 00 stranded copper T. B. W. wire.

If the common wire differs in size from the outside wires, use the average resistance as  $r$  in the formulae. (The resistance of one outside wire plus the resistance of the common wire, divided by two.) Treat the reactance in the same manner. Then use these average values to find  $\frac{x}{r}$  and proceed in a similar manner as when all wires are of equal size.

#### 41. Three-Phase Transmission.

The following problem illustrates the effect of capacity current:

Find the power loss and voltage drop in per cent, when transmitting 20,000 kw. at 100,000 volts, 85% power-factor, on a three phase, 60 cycle line 100 miles long, using 250,000 cir. mil. aluminum conductors, spaced 10 feet from center to center.

From Table 51, Sec. 3, find the charging current,  $I_{oc}$  per 1000 ft. of line, per 1,000 volts =  $0.0529 \times 10^{-3}$

$$I_c = \frac{I_{oc} \times 1 \times 5.28 \times E}{1000} = \frac{0.0529}{100} \times 100 \times 5.28 \times \frac{100,000}{1,000}$$

$$I_c = 27.95 \text{ amperes.}$$

$$I = \frac{20,000 \times 1,000}{2 \times 100,000} = 100 \text{ amperes.}$$

Table 36, Sec. 3. For aluminum cable  $r = 0.0679$  ohm.

Table 45, Sec. 3.  $x = 0.1462$  ohm.

$$\frac{x}{r} = \frac{0.1462}{0.0679} = 2.16$$

$$\frac{I_c}{I} = \frac{27.95}{100} = 0.2795$$

$$e' = \frac{2 r l I}{10 E} = \frac{2 \times 0.0679 \times 5,280 \times 100 \times 100}{10 \times 100,000} = 7.16\%$$

Table 59, Sec. 7, for  $\frac{I_c}{I} = .2795$  and 85% power-factor find  $b = 1.230$ .

Table 60, Sec. 7 for  $b = 1.230$  find power-factor = 90%

Table 61, Sec. 7 for 90% power-factor and  $\frac{x}{r} = 2.16$  find  $a = 2.18$

Table 62, Sec. 7 for 90% power-factor, 3-phase find  $q = 1.282$

$$e = 7.16 \times 2.18 = 15.4\%$$

$$p = 7.16 \times 1.233 = 8.68\%$$

$$I_0 = 100 \times 1.282 = 128.2 \text{ amperes.}$$

Voltage at the generator =  $1.154 \times 100,000 = 115,400$  volts

Power at the generator =  $1.0868 \times 20,000 = 21,735$  kw.

$$\cos. \theta_g = 90 \times \frac{1.0868}{1.154} = 84.5\%$$

$$\frac{I'_c}{I} = 0.2795 \times \frac{(1.154)^2}{1.0868} = 0.343$$

Apply these values to Table 59, Sec. 7 and find  $b' = 1.219$ .

In Table 60, Sec. 7 for  $b' = 1.219$  find 90.5% power-factor at the generator.

The rise in voltage at no load is

$$e = \frac{57 \times I^2 \times l^2}{10^6}$$

$$e = \frac{57 \times 100 \times 100 \times 60 \times 60}{10^6} = 2.05\%$$

Therefore the actual voltage variation at the generating station from no load to full load is  $15,400 + 2,050 = 17,450$  volts.

To determine if the conductor is of sufficient size to carry the load current, obtain  $q$  from Table 62 for a three-phase circuit and 90% power-factor.  $q = 1.282$ .

$$I_0 = 1.282 \times 100 = 128.2 \text{ amperes.}$$

The current 128.2 amperes is within the allowable current carrying capacity of a 250,000 cir. mil. cable. (Sec. 3.)

#### 42. Graphical Solution of a Three-Phase Transmission Line.

The proceeding problem is solved graphically in Fig. 297. More



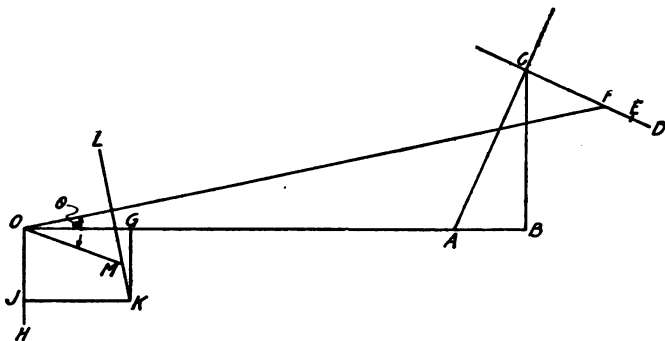

FIG. 297.

accurate values will be obtained by the graphical method if drawn to a large scale.

Obtain  $I_c$ ,  $I$ ,  $\frac{x}{r}$  and  $e'$  in the same manner as obtained in Article 41.

$$I_c = 27.95 \text{ amperes. } I = 100 \text{ amperes, } \frac{I_c}{2I} = 0.1397$$

$$\frac{x}{r} = 2.16; e' = 7.16. \text{ In Sec. 1, for } \cos. \theta = 0.85 \text{ find } \tan. \theta = 0.62.$$

In Fig. 297, lay off  $OA$  to the scale of  $E = 100,000$  volts. Draw  $AB$  from  $A$  and parallel to  $OA = \frac{E e'}{100} = \frac{100,000 \times 7.16}{100} = 7,160$  volts.

At  $90^\circ$  from  $AB$  draw  $BC = \frac{E e'}{100} \times \frac{x}{r} = \frac{100,000 \times 7.16}{100} \times 2.16 = 15,450$

volts. Draw  $AC$ . Draw  $CD$  at right angles to  $AC$  and through the point  $C$ . Scale  $AC = 17,028$  volts, lay off  $CE = AC \tan. \theta = 10,540$  volts.

From  $E$  lay off  $EF$  toward  $C$ , equal to  $AC \times \frac{I_c}{2I} = 17028 \times 0.1397 = 2379$  volts. Connect  $O$  and  $F$  and scale this distance. The value obtained is 115,300 volts. This is the generator voltage.

Lay off  $OG$  to the scale of  $I = 100$  amperes. Lay off  $OH = I \tan. \theta = 100 \times 0.62 = 62$  amperes. From  $H$  toward  $O$  lay off  $-HJ = \frac{I_c}{2} = 13.97$  amperes. Draw  $JK$  and  $GK$  parallel respectively to  $OA$  and  $OH$ . Draw  $KL$  from  $K$  and at right angles to  $OF$ . Lay off  $KM = \frac{I_c}{2} \times \frac{E'}{E} = 16.12$ . Draw  $OM$  and scale;  $OM = 103.5$  amperes.

With a protractor measure the angle between **OM** and **OF**. This angle is 24 degrees. In Sec. 1, find  $\text{Cos. } (24^\circ) = 0.9135$ , which is the power-factor of the generator, —91.35%.

The per cent power loss is found as follows:

**Single phase:**

$$\frac{E' I_g \cos. \Theta_g}{10 W} - 100$$

**For polyphase:**

$$\frac{2 E' I_g \cos. \Theta_g}{10 W} - 100$$

$$p = \frac{2 \times 115,400 \times 103.5 \times 0.9135}{10 \times 20,000} - 100 = 9.2\%$$

Fig. 297 is not drawn to scale as the values of **AB**, **BC**, etc., are so small in comparison to **OA** that they will not definitely show the construction. Obviously however, in laying this off an exact scale must always be maintained. The values for power loss as obtained graphically and as obtained from calculation do not agree. The graphical value may be in error, since large quantities are calculated and a small error in the quantities may make a large error in their difference.

**43. Additions to Existing Systems.** Where the voltage of a transmission extension is fixed due to its connection to an existing system, the calculations may be greatly simplified by means of a table, such as Table 63. This has been calculated from Tables 59 and 61.

Table 63 gives the per cent power loss and the per cent voltage drop per 1000 kw. per 1000 feet of line for 3 phase, 60 cycle, 13200 volt transmission, with a separation between wires of 24 inches. Only four sizes of wire have been considered. A problem will show the simplicity of this method.

**Problem:** It is desired to transmit 5000 kw., 20,000 ft. at a power-factor of 80%. What is the power loss and voltage drop in per cent?

**Solution.** It is necessary to use a No. 0000 copper wire in order to secure proper current carrying capacity. (Table 64.)

In Table 63, for No. 0000 copper wire and 80% power-factor  $e = 0.0782$  per 1000 ft. per 1000 kw. The total voltage drop is  $0.0782 \times 5 \times 20 = 7.82\%$ .  $p = 0.0438$  per 1000 ft. per 1000 kw.; therefore, the total power loss is  $0.0438 \times 5 \times 20 = 4.38\%$ .

All calculations in the above problems have been made with a slide rule. No corrections were made for change in resistance due to temperature. This may be readily allowed for, however, as shown in Sec. 3.

## Sec. 7 ELECTRICAL CALCULATIONS

When large cables are used, it is also necessary to correct the resistance for the skin effect. For such corrections the values of resistance taken from the table are multiplied by the factors given in Table 25, Sec. 3.

For copper covered steel wire, the resistance in the table must be increased by the percentage indicated in curves Figs. 78-81, Sec. 3, for copper covered steel. The increase in internal inductance of copper covered and aluminum core steel wire, is very small and need not be considered. However, if it is so desired, curves Figs. 84-87 shown in Sec. 3 for copper covered steel wire may be used. The percentages there given apply only to the factors 0.0152 and 0.0305 in the formulæ for inductance.

### 44. Alternating Current Series System.

#### Symbols:

- E = voltage of each lamp.
- E' = voltage at the generator.
- l = length of the line in feet.
- I<sub>0</sub> = current of the circuit in amperes.
- r = resistance per 1,000 ft. of wire in ohms.
- cos.  $\theta$  = power-factor of the circuit.
- N = number of lamps.
- a = factor in Table 61, Sec. 7.

$$E' = N E + \frac{a r l I_0 \cos. \theta}{1,000}$$

#### Problem:

Find the voltage at the generator when No. 6 copper wire is used to transmit energy for 100, 60 cycle, 80 volt, 6.6 ampere arc lamps at a power-factor of 70%. The total length of the line, which is erected 30 feet from the ground, is 20,000 ft.

From the inductance formulæ, Art. 29, calculate  $x$  for 1,000 feet of line.

$$x = 0.5342 \text{ (approximate).}$$

$$r = 0.3944.$$

$$\frac{x}{r} = 1.35.$$

In Table 61, for 70% power-factor and  $\frac{x}{r} = 1.35$  find  $a = 2.37$

$$E' = (100 \times 80) + \left( \frac{2.37 \times 0.3944 \times 20,000 \times 6.6 \times 0.7}{1,000} \right)$$

$$E' = 8,000 + 86.4 = 8,086.4 \text{ volts}$$

From this it may be seen that for most series alternating current circuits the line drop is negligible.

**TABLE 63**  
**PER CENT POWER LOSS AND VOLTAGE DROP PER 1000 KILOWATTS PER 1000 FT. OF**  
**LINE 3-PHASE, 60 CYCLES, 13,200 VOLTS, 24" SPACING OF WIRE**

		POWER-FACTOR													
B. & S. Gauge		1.00		.95		.90		.85		.80		.70		.60	
		e	p	e	p	e	p	e	p	e	p	e	p	e	p
0000		.0345	.0281	.0538	.0812	.0635	.0345	.0732	.0388	.0438	.0948	.0573	.1148	.078	.078
0		.0598	.0543	.0850	.0825	.0822	.0822	.0778	.1075	.0877	.1265	.1145	.147	.1562	.1562
2		.1142	.1128	.1376	.125	.15	.1388	.18	.1554	.178	.187	.23	.21	.2135	.2135
6		.226	.228	.254	.251	.27	.278	.278	.312	.287	.312	.451	.342	.452	.452

**TABLE 64**  
**MAXIMUM ENERGY IN KW. THAT MAY BE TRANSMITTED AT 13,200 VOLTS, THREE-**  
**PHASE (HEATING LIMIT OF WIRE) -**

		POWER-FACTOR						
B. & S.	Gauge	1.00	.95	.90	.85	.80	.70	.60
		0000	7132	6775	6419	6082	5706	4952
0	4239	4018	3806	3585	3333	2960	2537	
2	2515	2389	2264	2139	2012	1761	1509	
6	1486	1413	1357	1283	1189	1040	852	

**45. CHOICE OF VOLTAGE ON TRANSMISSION LINES.**

Some of the conditions determining transmission line voltages are as follows:

(1) The density of population in the territory through which it is proposed to run the line. This, to a certain extent, determines the amount of load.

(2) The character of the district; that is, whether it is a residential or a mill district, which determines the type, power-factor and diversity factor of the load.

(3) The probable extension of the line to care for increased growth in the section, or to supply energy to manufacturing establishments in territory beyond.

(4) The voltage of the existing system.

(5) The ratio of the proposed load to the station load. This determines whether or not it is desirable to operate a system of different voltage requiring special transformers, etc.

(6) Economic conditions. See Art. 60, Sec. 7.

From tables 71 and 72, Sec. 7, are found values of current density under certain load assumptions for different cost per kw. hour and per pound of conductor. These values are used in the following formulæ:

E = transmission voltage.

l = length of the line in feet.

p = per cent power loss.

q = see Table 62.

c = current density in amperes per cir. mil (Tables 71 and 72.)

$\rho$  = resistance per mil foot of conductor.

k = 2 for single-phase and 2-phase; 1.5 for 3-phase.

**Direct current:**

$$E = \frac{200 \rho l c}{p}$$

**Alternating current; single phase and polyphase.**

$$E = \frac{100 \rho k l c q}{p}$$

In using these formulæ an odd voltage is nearly always obtained. It is generally desirable to use the next higher standard voltage as the radius of transmission is thereby extended.

**46. CORONA AND CORONA LOSS.** When a given potential gradient in the air surrounding a conductor at high potential is exceeded, the wire becomes luminous, due to a breakdown of the air. This phenomenon is called Corona. A certain amount of energy is required to ionize the air before Corona occurs. For this reason the visual corona forming voltage, is higher than the voltage at which loss would otherwise occur. The laws of corona for-

mation and energy loss have been investigated by Mr. F. W. Peek, Jr., and the formulæ devised by him follow.

The loss during storms is considerably greater than that occurring in fair weather, but the factors controlling it are so varied that mathematical calculations applying thereto are very intricate. Investigation has shown that fairly accurate results may be obtained for stormy conditions by using 80% of the voltage at which loss occurs during fair weather.

#### Symbols:

- $l$  = length of line in miles.
- $n$  = number of wires.
- $p$  = power loss in kilowatts per mile of conductor.
- $e$  = effective kilovolts to neutral (line voltage).
- $e_0$  = effective disruptive critical voltage to neutral in kilovolts.
- $e_v$  = effective visual critical voltage to neutral in kilovolts.
- $k'$  = 552.
- $g_0$  = 53.6.
- $\delta$  =  $17.91 b$
- $\delta$  =  $459 + t$
- $b$  = barometric pressure in inches of mercury.
- $t$  = temperature in degrees fahrenheit.
- $r$  = radius of conductor in inches.
- $d$  = spacing between the conductors in inches.
- $f$  = frequency in cycles per second.
- $m_0$  = irregularity factor.
- $m_0 = 1$  for polished wires.
- $m_0 = 0.98$  to  $0.93$  for roughened or weathered wires.
- $m_0 = 0.87$  to  $0.83$  for seven strand cables.
- $m_v = m_0$  for wires.
- $m_v = 0.72$  for local corona along a seven strand cable.
- $m_v = 0.82$  for decided corona along a seven strand cable.

The effective disruptive critical voltage to neutral is

$$e_0 = 2.302 m_0 g_0 \delta r \log_{10} \frac{d}{r}$$

The visual critical voltage to neutral is

$$e_v = 2.302 m_v g_0 r \left( \log_{10} \frac{d}{r} \right) \delta \left( 1 + \frac{0.189}{\sqrt{\delta r}} \right)$$

The power loss in kilowatts is

$$\begin{aligned} \text{Power loss} &= n l p \\ p &= \frac{k'}{\delta} \frac{f}{10^6} \sqrt{\frac{r}{d}} (e - e_0)^2 \end{aligned}$$

Sec. 7

ELECTRICAL CALCULATIONS

These formulæ may be greatly simplified for convenient use by calculating tables similar to inductance tables. Formulæ applying to these tables follow.

- E = effective kilovolts between wires.
- e = effective kilovolts to neutral.
- e<sub>0</sub> = effective disruptive, critical voltage to neutral in kilovolts.
- e<sub>v</sub> = effective visual critical voltage to neutral in kilovolts.
- P = total energy loss in kilowatts due to corona discharge.

$$k_1 = 104.5 \times \sqrt{\frac{r}{d}} \quad \text{Table 66.}$$

$$k_2 = 123.4 \, r \log_{10} \frac{d}{r} \quad \text{Table 67.}$$

$$k_3 = \delta \left( 1 + \frac{0.189}{\sqrt{\delta r}} \right) \quad \text{Table 68.}$$

- n = number of wires.
- l = length of line in feet.

$$\delta = \text{air density factor} = \frac{17.91 \, b}{459 + t} \quad \text{Table 65.}$$

The remaining factors are the same as in the above formulæ.

$$\text{For single phase } e = \frac{E}{2}$$

$$\text{For two phase } e = \frac{E}{2}$$

$$\text{For three phase } e = \frac{E}{\sqrt{3}}$$

$$e_0 = m_0 \, \delta \, k_2$$

$$e_v = m_v \, k_2 \, k_3$$

$$P = \frac{n \, l \, f \, k_1}{10^8 \, \delta} (e - e_0)^2$$

In addition to the condition of the wire, a factor which has great influence on corona phenomena, is the air density factor  $\delta$ . This varies directly with the barometric pressure, and inversely with the absolute temperature. The barometric pressure at sea level will vary from a maximum of about 30.90 inches of mercury in fair weather to 29.00 inches of mercury in stormy weather. A fair average condition being 29.92 inches.

As some suitable basis must be chosen in all calculations, this value of 29.92 inches has been taken as a basis from which the values of  $\delta$  were calculated for different temperatures and for different altitudes. These values of  $\delta$  have been inserted in Table 65.

TABLE 65  
VALUES OF  $\delta$

Feet above SeaLevel		TEMPERATURE IN DEGREES F.										
		-20°	-10°	0°	10°	20°	30°	40°	50°	60°	70°	80°
0	1.22	1.197	1.169	1.143	1.120	1.096	1.073	1.053	1.033	1.012	.995	.976
500	1.197	1.171	1.145	1.120	1.096	1.073	1.055	1.033	1.014	.996	.979	.961
1000	1.172	1.149	1.121	1.098	1.078	1.057	1.033	1.018	.998	.980	.961	.945
1500	1.15	1.125	1.099	1.080	1.059	1.033	1.018	.998	.981	.964	.947	.930
2000	1.125	1.108	1.080	1.060	1.038	1.019	1.000	.982	.964	.948	.931	.916
2500	1.11	1.081	1.060	1.042	1.021	1.001	.984	.965	.950	.932	.916	.900
3000	1.082	1.062	1.045	1.021	1.002	.986	.966	.950	.935	.919	.903	.889
3500	1.063	1.045	1.025	1.005	.987	.968	.951	.935	.920	.905	.889	.878
4000	1.047	1.028	1.007	.989	.970	.954	.936	.921	.907	.891	.878	.865
4500	1.028	1.012	.996	.972	.954	.939	.922	.908	.894	.880	.866	.854
5000	1.012	.993	.974	.956	.940	.925	.908	.895	.881	.869	.856	.844
5500	.995	.976	.965	.945	.927	.911	.895	.884	.869	.858	.845	.831
6000	.977	.961	.943	.923	.913	.899	.885	.871	.859	.845	.833	.819
6500	.963	.946	.930	.915	.900	.887	.875	.859	.848	.832	.822	.810
7000	.946	.931	.915	.900	.889	.875	.860	.846	.835	.825	.810	.794



If it is desired to use any other sea level barometric pressure than 29.92 inches as a basis, calculated corrections should be made. (Sec. 11.) Inspection of Table 65 will show that an increase of 500 feet above sea level makes practically the same difference in  $\delta$  as an increase in temperature of 10°F. To extend the tables for temperatures beyond the range given, proceed as follows:

If it is desired to find the value  $\delta$  for 2000 ft. above sea level and a temperature of 120°F. In Table 65 for 2000 feet and 90° is found the factor 0.916. 120° is 30° above 90°, therefore by adding 1500 feet to 2000 feet, the value of  $\delta$  for 2000 feet and 120° is found to be 0.876; the value for 3500 feet and 90°F. This is an approximation only.

The values of  $k_1$  are given in Table 66 for various distances between wires and for various sizes of wire, both stranded and solid. This has been multiplied by a constant so that "1" may be used in feet rather than in miles in order to conform to the other tables.

The values of  $k_2$  in Table 67 have been calculated for various distances between wires and for various radii of wires. To find the visual corona forming voltage, it is necessary to use the value of  $k_2$  which has been calculated for various values of  $\delta$  and for various radii of stranded and solid wire. The method of using these tables is illustrated in the following problem.

#### Problem:

Find the power loss and corona forming voltage on a No. 00 B. & S. stranded copper wire, located 6000 feet above sea level, for fair and stormy weather; on a three phase, three wire, 60 cycle line, 100 miles long, operated at 88,000 volts; wires spaced 10 feet apart and an air temperature of 70° F.

$$l = 528,000$$

$$n = 3$$

In Table 65 for 70° F and 6000 ft.  $\delta = 0.845$

Table 66 for 10 ft. spacing and No. 00 stranded copper wire  $k_1 = 4.38$

Table 67 for 10 feet spacing and No. 00 stranded copper wire  $k_2 = 71.44$

For No. 00 stranded copper wire and  $\delta = 0.845$ .

Interpolate Table 68 and find  $k_3 = 1.22$

$$m_o = 0.87 \quad (\text{See symbols.})$$

$$m_v = 0.72 \text{ for local corona and}$$

$$m_v = 0.82 \text{ for decided corona}$$

$$e = \frac{E}{\sqrt{3}} = \frac{88}{\sqrt{3}} = 50.88 \text{ kilovolts.}$$

$$e_o = 0.87 \times 0.845 \times 71.44 = 52.51$$

$$e_v = 0.72 \times 71.44 \times 1.22 = 62.76$$

Fair weather —  $e$  is less than  $e_o$

TABLE 66						
VALUES OF $K_1$						
$K_1 = 104.5 \times \sqrt{\frac{r}{d}}$						
Stranded	SEPARATION OF WIRES IN FEET					
	2	4	6	8	10	12
500,000	13.69	9.32	7.86	6.85	6.09	5.57
450,000	13.28	9.26	7.64	6.64	5.94	5.40
400,000	12.86	9.11	7.43	6.38	5.76	5.26
350,000	12.44	8.79	7.16	6.21	5.55	5.07
300,000	12.02	8.46	6.91	5.96	5.35	4.89
250,000	11.60	8.19	6.69	5.79	5.19	4.74
0000	10.98	7.76	6.34	5.49	4.91	4.48
000	10.30	7.30	5.97	5.17	4.62	4.22
00	9.77	6.91	5.65	4.89	4.38	3.99
0	9.24	6.53	5.33	4.63	4.13	3.77
1	8.67	6.14	5.01	4.34	3.88	3.54
Solid						
0000	10.29	7.24	5.91	5.12	4.58	4.17
000	9.66	6.83	5.58	4.83	4.32	3.94
00	9.06	6.45	5.26	4.56	4.06	3.71
0	8.60	6.08	4.97	4.31	3.85	3.51
1	8.11	5.72	4.76	4.06	3.63	3.36
2	7.67	5.42	4.75	3.84	3.41	3.13
3	7.24	5.11	4.17	3.62	3.19	2.96
4	6.83	4.83	3.94	3.42	3.05	2.79
5	6.45	4.56	3.71	3.22	2.89	2.63
6	6.08	4.31	3.51	3.04	2.69	2.45

Therefore  $p = 0$

$$\text{Stormy weather } p = \frac{3 \times 528,000 \times 60 \times 4.38}{0.845 \times 10^6} [50.88 - (0.8 \times 52.51)]^2$$

$$= 389.0 \text{ kw.}$$

The following facts should be noted:

The voltage along a transmission line is not constant, but varies depending upon the distance from the station, the amount of load, the power-factor, etc. Therefore, the power loss due to corona is necessarily a summation of short lengths of line, in which the voltage at both ends is assumed to be equal. When corona exists on a wire,

TABLE 67 VALUES OF $K_2$ $K_2 = 123.4 r \log_{10} \frac{d}{r}$						
Stranded	SEPARATION OF WIRES IN FEET					
	2 1	4	6	8	10	12
500,000	89.20	104.38	113.28	119.59	124.49	127.20
450,000	85.26	99.57	106.72	113.88	118.44	122.15
400,000	81.68	97.25	103.15	108.20	113.02	115.48
350,000	77.36	93.94	97.35	102.53	106.60	109.93
300,000	73.16	94.76	91.67	96.73	100.31	103.39
250,000	69.59	90.44	86.86	91.42	95.00	97.84
0000	64.03	73.78	79.58	83.66	86.86	89.45
000	58.24	67.00	72.05	75.76	78.47	80.81
00	53.30	61.07	65.78	68.97	71.44	73.53
0	48.74	55.77	59.84	62.68	64.90	66.75
1	44.05	50.22	53.79	56.26	58.24	61.07
Solid						
0000	57.25	65.76	70.82	74.40	77.11	79.23
000	52.31	59.96	64.53	67.49	69.95	72.05
00	48.98	55.89	60.09	62.92	65.14	67.09
0	43.55	49.48	53.05	55.52	57.50	59.10
1	39.60	44.91	48.12	50.34	52.07	53.42
2	36.15	40.96	43.68	45.65	47.25	48.49
3	32.82	37.01	39.48	41.23	42.69	43.80
4	29.86	33.56	35.78	37.38	38.62	39.80
5	27.14	30.60	32.57	33.93	35.04	35.90
6	24.68	27.64	29.49	30.72	31.71	32.45

the capacity of the line is increased due to the increase in effective diameter.

For complete details covering corona phenomena see A.I.E.E. proceedings of July 1911, June 1912 and June 1913.

**47. LOCATING THE CENTER OF DISTRIBUTION.** When several loads are distributed along an approximately straight line and it is desired to locate the center of distribution, the method is as follows (Fig. 298):

$W_1, W_2, W_3, W_4$ , etc., denote the kilowatt capacity of the respective loads. Through  $W_1, W_2, W_3, W_4$ , etc., draw the line  $OX$ , and at any point on the line  $OX$  locate a point  $O$ . The distance from this

point to  $W_1, W_2$ , etc., designate as  $l_1, l_2, l_3, l_4$ , etc. These lengths may be in feet or in miles.

Let  $l_x$  = the distance from  $O$  to the center of distribution  $G$ , then:

$$l_x = \frac{l_1W_1 + l_2W_2 + l_3W_3 + l_4W_4 \text{ etc.}}{W_1 + W_2 + W_3 + W_4 \text{ etc.}}$$

In which  $l_x$  is the distance from  $O$  (in feet or miles according to the values of  $l_1, l_2$ , etc.) to the center of distribution. If the point  $O$  is taken at one of the loads,  $W_1$ , the equation is slightly simplified. The distances in this case are measured from  $W_1$ , and therefore  $l_1$  will equal zero, and the equation becomes

$$l_x = \frac{l_2W_2 + l_3W_3 + l_4W_4 \text{ etc.}}{W_1 + W_2 + W_3 + W_4 \text{ etc.}}$$

The distance  $l_x$  is laid off from  $W_1$  giving the same point  $G$ . The power loss increases as the square of the distance between the actual point of the feed and the point  $G$ .

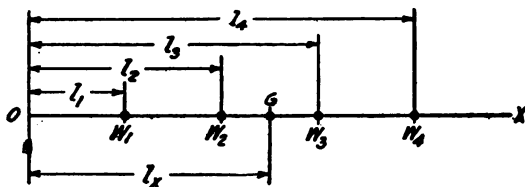

FIG. 298.

Where loads are located at various points, not on a straight line, as shown in Fig. 299, the following procedure is adopted:

Let

$W_1, W_2, W_3$ , etc. = respective loads.

Draw the line  $OX$  through any convenient point so that the loads are all located on one side of the line. Draw  $OY$  at right angles to  $OX$  so that all the loads are included in the angle between  $OY$  and  $OX$ . Let  $l_1, l_2, l_3$ , etc., be the distance between  $OY$  and the loads in feet or miles. Let  $l'_1, l'_2, l'_3$ , etc., be the distance between  $OX$  and the respective loads. Let  $l_x$  be the distance between the center of distribution  $G$  and  $OY$  and  $l_y$  be the distance between the center of distribution  $G$  and  $OX$ .

Then

$$l_x = \frac{W_1l_1 + W_2l_2 + W_3l_3 \text{ etc.}}{W_1 + W_2 + W_3 \text{ etc.}}$$

and

$$l_y = \frac{W_1l'_1 + W_2l'_2 + W_3l'_3 \text{ etc.}}{W_1 + W_2 + W_3 \text{ etc.}}$$

TABLE 68  
VALUES OF  $K_3 = \delta \left( 1 + \frac{0.189}{\sqrt{\delta r}} \right)$

Size wire	Values of $\delta$											
	.70	.75	.80	.85	.90	.95	1.00	1.05	1.10	1.15	1.20	1.25
Stranded												
500,000	.947	1.006	1.064	1.122	1.180	1.238	1.295	1.353	1.411	1.456	1.524	1.581
450,000	.955	1.014	1.072	1.130	1.189	1.246	1.304	1.362	1.419	1.476	1.534	1.591
400,000	.962	1.021	1.080	1.138	1.197	1.255	1.313	1.371	1.428	1.486	1.546	1.604
350,000	.972	1.031	1.090	1.149	1.208	1.266	1.324	1.382	1.440	1.497	1.555	1.612
300,000	.982	1.041	1.101	1.160	1.220	1.278	1.336	1.394	1.452	1.511	1.569	1.628
250,000	.991	1.052	1.111	1.171	1.230	1.289	1.348	1.407	1.464	1.523	1.581	1.639
0000	1.007	1.068	1.128	1.188	1.248	1.307	1.366	1.426	1.484	1.543	1.601	1.66
000	1.026	1.087	1.148	1.209	1.270	1.329	1.389	1.449	1.508	1.568	1.620	1.685
00	1.045	1.107	1.168	1.230	1.291	1.351	1.412	1.473	1.531	1.592	1.651	1.711
0	1.065	1.128	1.190	1.252	1.314	1.375	1.436	1.498	1.557	1.618	1.678	1.738
1	1.089	1.152	1.215	1.278	1.341	1.402	1.465	1.526	1.586	1.648	1.709	1.770
Solid												
0000	1.080	1.091	1.152	1.213	1.274	1.334	1.394	1.454	1.512	1.572	1.631	1.690
000	1.049	1.111	1.172	1.234	1.296	1.356	1.416	1.477	1.537	1.597	1.654	1.716
00	1.070	1.133	1.195	1.257	1.319	1.380	1.442	1.504	1.563	1.624	1.684	1.746
0	1.092	1.155	1.219	1.281	1.345	1.408	1.468	1.530	1.590	1.652	1.713	1.774
1	1.116	1.180	1.245	1.308	1.371	1.435	1.497	1.560	1.620	1.683	1.745	1.809
2	1.140	1.205	1.270	1.335	1.400	1.465	1.526	1.590	1.651	1.714	1.776	1.838
3	1.167	1.233	1.299	1.364	1.430	1.494	1.557	1.622	1.684	1.748	1.811	1.875
4	1.194	1.262	1.328	1.393	1.461	1.523	1.581	1.643	1.709	1.768	1.831	1.894
5	1.224	1.292	1.359	1.426	1.494	1.560	1.626	1.692	1.756	1.826	1.885	1.950
6	1.255	1.325	1.394	1.461	1.530	1.596	1.664	1.730	1.795	1.861	1.927	1.991

These two values measured respectively from OY and OX, and at 90 degrees from the same, give the location of the point G.

The equations may be slightly simplified by taking OX and OY through one of the loads. If OX and OY are drawn through  $W_3$ , the following formulae will apply.

$$l_x = \frac{W_1 l_1 + W_2 l_2 \text{ etc.}}{W_1 + W_2 + W_3 \text{ etc.}}$$

and

$$l_y = \frac{W_1 l'_1 + W_2 l'_2 \text{ etc.}}{W_1 + W_2 + W_3 \text{ etc.}}$$

Distances that were formerly  $l_3$  and  $l'_3$  are now zero and the distance  $l_1$ ,  $l'_1$ ,  $l_2$ ,  $l'_2$ , etc. are measured from OX and OY running

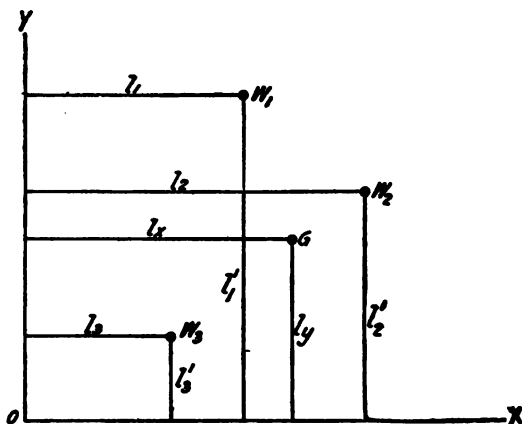

FIG. 299.

through  $W_3$ ;  $l_x$  and  $l_y$  are measured from these lines passing through  $W_3$  giving the same location of G as before. The power loss increases as the square of the distance between the location of the actual point of feed and G. If OX and OY in Fig. 299, or the point O in Fig. 298, are located between the loads so that some of the loads fall on one side and some on the other side of the lines or point, it is necessary to place a negative sign before the loads times the distances on one side of the lines or point, and a positive sign before the loads times the distances on the other side of the lines or point.

In calculations for alternating current systems, the kilovolt amperes of the load should be used rather than the kilowatts, i.e.  $W_1$ ,  $W_2$ , etc. equal the kilovolt amperes of the respective loads.

Also, when making the above calculations care must be taken

## Sec. 7

## ELECTRICAL CALCULATIONS

to use the actual lengths of the distribution lines rather than the air lines, provided, however, that this manner of calculation does not hopelessly complicate the problem.

### 48. CALCULATION OF TRANSFORMER CAPACITY.

Let

- $W$  = the total kw. capacity of the delivered load.  
 $\cos. \theta$  = the power-factor of load.  
 $q$  = the factor given in Table 62, Sec. 7, for different systems and power-factors.  
 $kv-a$  = kilovolt ampere capacity of each single transformer in the bank.  
 $E$  = the effective voltage on any system, i.e. on a single phase, 3-wire system, it is the voltage between the outside wires. On a 3-phase Y connected system, it is the delta voltage; on a 2-phase, 3-wire system, it is the voltage between the common wire and the outside wire. On a 2-phase, 5-wire system, it is the voltage between the phase wires and not from the neutral to the phase wires. In all other systems it is the voltage between phase wires.  
 $I_o$  = line current.  
 $E_t$  = voltage across transformer primary winding.  
 $I_t$  = the current in the transformer primary winding.  
 $E_s$  = voltage of secondary system and bears the same relation to the manner of connection as  $E$  in the primary.  
 $I_s$  = the secondary line current.  
 $E'_t$  = the voltage across transformer secondary winding.  
 $I'_t$  = current in the transformer, secondary winding.

Table 69 gives the ratio that these various factors bear to one another.

#### (I) Problem:

Find the capacity of three transformers required to transmit 1,200 kilowatts at 80% power-factor. The system is three phase, three wire  $\Delta$  primary and Y secondary.

#### 1st Method:

$$kv-a. \text{ of each transformer is } \frac{W}{3 \times \cos. \theta} = \frac{1200}{3 \times 0.8} = 500 \text{ kv-a.}$$

#### 2nd Method:

$$kv-a. = \frac{W q}{2\sqrt{3}} = \frac{1200}{2 \times \sqrt{3}} \times 1.443 = 500 \text{ kv-a.}$$

In this problem, the first method is the more simple. Assuming 2,200 volts between primary wires and 220 volts between secondary

wires, the primary and secondary current of each transformer is found as follows:

$$I_o = \frac{W}{\sqrt{3} E \cos. \theta} = \frac{1,200,000}{\sqrt{3} \times 2,200 \times 0.8} = 393.5 \text{ amperes.}$$

The current in each transformer primary winding is:

$$I_t = \frac{I_o}{\sqrt{3}} = \frac{394}{\sqrt{3}} = 227 \text{ amperes.}$$

The voltage of each transformer primary winding is:

$$E_t = E = 2200 \text{ volts.}$$

The current in each transformer secondary winding is:

$$I'_t = I_s = 3935 \text{ amperes.}$$

The voltage of each transformer secondary winding is:

$$E'_t = \frac{E_s}{\sqrt{3}} = \frac{220}{\sqrt{3}} = 127 \text{ volts.}$$

Assume that all conditions are similar except that the secondary is a three-phase four-wire system and the potential is 220 volts between the neutral wire and the outside wires.

Then,

$$E_s = 220 \times \sqrt{3}$$

$$I_s = \frac{1,200,000}{\sqrt{3} \times 220 \sqrt{3} \times 0.8} = 2,270 \text{ amperes.}$$

$$I'_t = I_s = 2,270 \text{ amperes.}$$

$$E'_t = \frac{E_s}{\sqrt{3}} = \frac{220 \sqrt{3}}{\sqrt{3}} = 220 \text{ volts.}$$

### (II) Problem:

A load of 1,200 kilowatts at 80% power-factor is to be transformed from 2,200 volts, three-phase, three-wire, to 220 volts, three-phase, three-wire, using V or open delta connections. Find the transformer capacity.

#### 1st Method:

$$\text{kv-a.} = \frac{W}{\sqrt{3} \cos. \theta} = \frac{1,200}{\sqrt{3} \times 0.8} = 866 \text{ kilovolt-amperes.}$$

#### 2nd Method:

$$\frac{W}{2} q = \frac{1,200}{2} \times 1.443 = 866 \text{ kilovolt-amperes.}$$



**TABLE 69**  
**CALCULATION OF TRANSFORMER CAPACITY**  
**Values of Symbols**

kv-a CAPACITY OF EACH TRANSFORMER					
System	kv-a	kv-a	$E_t$	$I_t$	Primary Connection
Single $\phi$ 2 and 3 wire	$\frac{W}{\text{Cos. } \theta}$	$Wq$	$E$	$I_o$	
2 $\phi$ 3, 4 and 5 wire	$\frac{W}{2\text{Cos. } \theta}$	$\frac{Wq}{2}$	$E$	$I_o$	
3 $\phi$ , 3 and 4 wire	$\frac{W}{3\text{Cos. } \theta}$	$\frac{Wq}{2\sqrt{3}}$	$E$	$\frac{I_o}{\sqrt{3}}$	$\Delta$
3 $\phi$ , 3 and 4 wire	$\frac{W}{3\text{Cos. } \theta}$	$\frac{Wq}{2\sqrt{3}}$	$E$	$\frac{I_o}{\sqrt{3}}$	$\Delta$
3 $\phi$ , 3 and 4 wire	$\frac{W}{3\text{Cos. } \theta}$	$\frac{Wq}{2\sqrt{3}}$	$\frac{E}{\sqrt{3}}$	$I_o$	Y
3 phase 4 wire	$\frac{W}{3\text{Cos. } \theta}$	$\frac{Wq}{2\sqrt{3}}$	$\frac{E}{\sqrt{3}}$	$I_o$	Y
3 phase 3 wire	$\frac{W}{\sqrt{3} \text{Cos. } \theta}$	$\frac{Wq}{2}$	$E$	$I_o$	V
2 $\phi$ to 3 $\phi$ Teaser Transformer*	$\frac{W}{2\text{Cos. } \theta}$	$\frac{Wq}{2}$	$E$	$I_o$	$\rightarrow 1$
2 $\phi$ to 3 $\phi$ Main Transformer	$\frac{W}{2\text{Cos. } \theta}$	$\frac{Wq}{2}$	$E$	$I_o$	$\frac{1}{\dagger}$
3 $\phi$ to 2 $\phi$ Teaser Transformer*	$\frac{W}{2\text{Cos. } \theta}$	$\frac{\sqrt{3}Wq}{4}$	$\frac{\sqrt{3}E}{2}$	$I_o$	$\rightarrow 1$
3 $\phi$ to 2 $\phi$ Main Transformer	$\frac{W}{\sqrt{3} \text{Cos. } \theta}$	$\frac{Wq}{2}$	$E$	$I_o$	$\frac{1}{\dagger}$

\* Assumes the teaser transformer wound for 86.6% of the line voltage; if an 86.6% tap is used the capacity is the same as the main transformer.

TABLE 69—Continued  
CALCULATION OF TRANSFORMER CAPACITY  
Values of Symbols

kv-a CAPACITY OF EACH TRANSFORMER					
System	kv-a		$E'_t$	$I'_t$	Secondary Connection
Single $\phi$ 2 and 3 wire	$\frac{W}{\text{Cos. } \theta}$	$Wq$	$E_s$	$I_s$	
2 $\phi$ 3, 4 and 5 wire	$\frac{W}{2\text{Cos. } \theta}$	$\frac{Wq}{2}$	$E_s$	$I_s$	
3 $\phi$ , 3 and 4 wire	$\frac{W}{3\text{Cos. } \theta}$	$\frac{Wq}{2\sqrt{3}}$	$\frac{E_s}{\sqrt{3}}$	$I_s$	Y
3 $\phi$ , 3 and 4 wire	$\frac{W}{3\text{Cos. } \theta}$	$\frac{Wq}{2\sqrt{3}}$	$E_s$	$\frac{I_s}{\sqrt{3}}$	$\Delta$
3 $\phi$ , 3 and 4 wire	$\frac{W}{3\text{Cos. } \theta}$	$\frac{Wq}{2\sqrt{3}}$	$E_s$	$\frac{I_s}{\sqrt{3}}$	$\Delta$
3 phase 4 wire	$\frac{W}{3\text{Cos. } \theta}$	$\frac{Wq}{2\sqrt{3}}$	$\frac{E_s}{\sqrt{3}}$	$I_s$	Y
3 phase 3 wire	$\frac{W}{\sqrt{3}\text{Cos. } \theta}$	$\frac{Wq}{2}$	$E_s$	$I_s$	V
2 $\phi$ to 3 $\phi$ Teaser Transformer*	$\frac{W}{2\text{Cos. } \theta}$	$\frac{\sqrt{3} Wq}{4}$	$\frac{\sqrt{3} E_s}{2}$	$I_s$	$\frac{1}{2}$
2 $\phi$ to 3 $\phi$ Main Transformer	$\frac{W}{\sqrt{3}\text{Cos. } \theta}$	$\frac{Wq}{2}$	$E_s$	$I_s$	$\frac{1}{3}$
3 $\phi$ to 2 $\phi$ Teaser Transformer*	$\frac{W}{2\text{Cos. } \theta}$	$\frac{Wq}{2}$	$E_s$	$I_s$	$\frac{1}{2}$
3 $\phi$ to 2 $\phi$ Main Transformer	$\frac{W}{2\text{Cos. } \theta}$	$\frac{Wq}{2}$	$E_s$	$I_s$	$\frac{1}{3}$

\* Assumes the teaser transformer wound for 86.6% of the line voltage; if an 86.6% tap is used the capacity is the same as the main transformer.

In this problem the second method is the more convenient.

The primary voltage and current, and the secondary voltage and current equal the line voltage and current.

For polyphase transformers it is only necessary to determine the total kv-a. by dividing the energy in kilowatts by the power-factor. The capacity of the individual windings are determined by the manufacturers.

NOTE: Many attempts have been made to so connect transformers on a polyphase system that each single phase load will be balanced on the polyphase system. It is possible to so connect transformers that the currents delivered to the single phase load from each phase of a polyphase system will be equal, but in such cases the power-factors will vary greatly. The fact that the transfer of energy in a single phase system is pulsating while that in a polyphase system is continuous indicates that it is impossible to preserve balanced conditions on a polyphase system for each single phase load without the aid of rotating machinery, in which the energy from the polyphase system may be stored in the rotating element of the machine in the form of mechanical energy during the period of zero energy transfer in the single-phase system.

49. Calculation of Transformer Regulation. The regulation of constant potential transformers is the ratio of the rise of secondary terminal voltage from rated non-inductive load to no load (at constant primary impressed terminal voltage) to the secondary terminal voltage at rated load. (A.I.E.E.) This is for 100% power-factor only, but holds true for other power-factors if in the definition "inductive load" is substituted for "non-inductive load."

The regulation of a transformer may be calculated by several methods when the resistance, the reactance, and the magnetizing current are known, one of which follows:

Let

$r$  = the total resistance of the transformer coils referred to the primary.

$x$  = the total reactance of the transformer coils referred to the primary.

kv-a. = capacity of transformer in kilovolt amperes.

$E$  = impressed primary voltage.

$I$  = energy component of load current.

$\cos. \theta$  = power-factor of the load as a decimal.

$I_m$  = magnetizing current.

$I_e$  = exciting current of transformer.

$w_c$  = core loss in watts.

Formulae:

$$I = \frac{\text{kv-a.} \times \cos. \theta \times 1000}{E}$$

$$a_o = \frac{x}{r}$$

$$e = \frac{rI}{E}$$

$$a = \tan. \theta + \frac{I_m}{I}$$

$$\tan. \alpha = \frac{a_0 - a}{\frac{1}{e} + (a_0 a) + 1}$$

$$\text{reg. \%} = 100 \left[ \frac{1 + e + e a_0 a}{\cos. \alpha} - 1 \right]$$

For most purposes  $\cos. \alpha$  is so near unity that it may be neglected and the formulae then become

$$\text{reg. \%} = 100 [e + e a_0 a]$$

The magnetizing component of the no-load current may be found as follows:

$$\cos. \beta = \frac{W_e}{E I_c}$$

$$I_m = \frac{W_e}{E} \tan. \beta$$

If the power-factor of the load is leading,  $\tan. \theta$  becomes negative, but the remainder to the formulae is the same.

#### Problem:

Find the regulation at 100%, and 80% (inductive load) power-factor of a 10 kv-a. 2,000 volt transformer having 8 ohms resistance and 32 ohms reactance referred to the primary winding. The exciting current = 0.5 amperes. The core loss is 600 watts.

$$\cos. \beta = \frac{600}{2,000 \times 0.5} = 0.6$$

In Sec. 1 for  $\cos. \beta = 0.6$  find  $\tan. \beta = 1.327$

$$I_m = \frac{600}{2,000} \times 1.327 = 0.398$$

For 100% power-factor

$$I = \frac{10,000 \times 1.}{2,000} = 5 \text{ amperes.}$$

$$e = \frac{8 \times 5}{2,000} = 0.02$$

$$a_0 = \frac{32}{8} = 4$$

**Sec. 7                      ELECTRICAL CALCULATIONS**

$$\tan. \theta = 0$$

$$\frac{I_m}{I} = \frac{0.398}{5} = 0.0796 = a$$

$$\tan. \alpha = \frac{4 - 0.0796}{\frac{1}{0.02} + (4 \times 0.0796) + 1} = \frac{3.9204}{51.3184} = 0.0765$$

In Sec. 1 for  $\tan. \alpha = 0.0765$  find  $\cos. \alpha = 0.997$

$$\text{reg. \%} = 100 \left[ \frac{1 + 0.02 + (0.02 \times 4 \times 0.0796)}{0.997} - 1 \right] = 2.9\%$$

By the more simple formula

$$\text{reg. \%} = 100 [0.02 + (0.02 \times 4 \times 0.0796)] = 2.64\%$$

For 80% power-factor

$$I = \frac{10,000 \times 0.8}{2,000} = 4 \text{ amperes}$$

$$e = \frac{8 \times 4}{2,000} = 0.016$$

$$a_0 = 4$$

$\tan. \theta = 0.75$  when  $\cos. \theta = 0.8$

$$\frac{I_m}{I} = \frac{0.398}{4} = 0.0995$$

$$a = 0.75 + 0.0995 = 0.8495$$

$$\tan. \alpha = \frac{4 - 0.8495}{\frac{1}{0.016} + (4 \times 0.8495) + 1} = 0.0471$$

Find  $\cos. \alpha = 0.999$

$$\text{reg. \%} = 100 \left[ \frac{1 + 0.016 + (0.016 \times 4 \times 0.8495)}{0.999} - 1 \right] = 7.15$$

By the shorter method

$$\text{reg. \%} = 100 [0.016 + (0.016 \times 4 \times 0.8495)] = 7.04\%$$

**50. Calculation of Transformer Efficiency.** The efficiency of a transformer is the ratio of the power output to the power input. The all-day efficiency of a transformer is the net power output for 24 hours divided by the gross power input for 24 hours.

W = kilowatts output (maximum).

r = resistance of transformer coils referred to the primary.

$I_o$  = primary load current.

$w_c$  = core loss in watts.

$$I_o = \frac{W}{E \cos. \theta}$$

$$\text{Efficiency \%} = 100 \left[ \frac{W}{W + \frac{w_c + rI_o^2}{1,000}} \right]$$

The all-day efficiency of a transformer expressed in per cent is:

$$= 100 \left[ \frac{24 W L}{24 W L + \frac{24 w_c}{1000} + \frac{\Sigma 24 r I^2}{1000}} \right]$$

In the above equation all the symbols are the same as previously used with the addition of  $L$  for the load factor as a fraction and  $\Sigma 24 r I^2$ , which is the summation of the power loss in resistance, where  $I$  is equal to the square root of the mean square of the current flowing for 24 hours and  $r$  is the resistance of the transformer coils referred to the primary.

### VOLTAGE REGULATORS

**51. General.** Automatic voltage regulators for pole line use permit better regulation and service from a long line with regularly distributed consumers for the greater part of its length. When regulators are installed along the line it becomes necessary to make calculations of regulator capacity and per cent regulation for various consumers' demands. Transformers may be used to increase the line voltage at a given point, but do not improve the line regulation, as the voltage addition is constant.

**52. Regulation.** To calculate the range of regulation necessary, data are required covering the variations of voltage at the point where the regulators are to be installed.

#### 53. Single-Phase System. (Fig. 300.)

Let

$V$  = the maximum effective voltage variation in volts.

$E$  = average effective line voltage between outside wires.

$e$  = per cent of regulation of regulators.

Then

$$e = \frac{V 100}{2 E}$$

The reason the percentage voltage regulation of a regulator is one-half the voltage variation of the line, lies in the fact that voltage regulators are so designed that the secondary voltage coil adds to,

## Sec. 7 ELECTRICAL CALCULATIONS

or subtracts from the line voltage, thus giving the regulator double the range of the voltage of the secondary coil.

**54. Two-Phase System.** If two single-phase regulators are used, the calculations are the same as for a single-phase system. If a

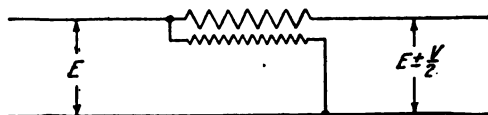

FIG. 300.

two-phase regulator is used  $V$  is the average of the phase voltages; otherwise the calculations are identical.

**55. Three-Phase, Three-Wire System.** Single-phase or poly-phase voltage regulators may be used for this service. When single-phase regulators are employed they should all have the same reg-

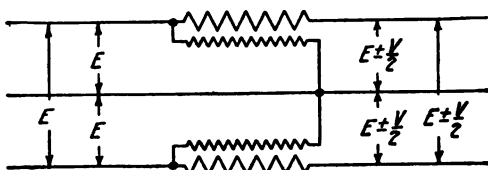

FIG. 301.

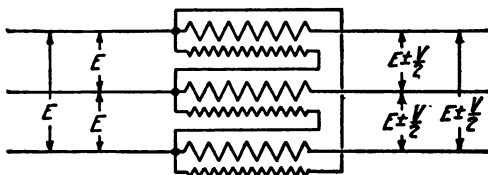

FIG. 302.

ulating characteristics. If two regulators are used, connected as in Fig. 301 the calculations for per cent regulation are the same as for single-phase regulators. If, however, three regulators are connected "Δ" as illustrated in Fig. 302, the per cent regulation must be found by the following formulae:

Accurate formulae:

$$e = 100 \sqrt{\frac{1 - 0.25 \left(\frac{V}{E}\right)^2}{\left(\frac{3E}{V}\right)^2 - 3}}$$

Approximate formulae (less than  $\frac{1}{2}$  of 1% error for commercial ranges)

$$e = \frac{100 V}{3 E}$$

The calculations for a polyphase regulator are the same as for a single-phase regulator with the exception that  $V$  is the average of the three-phase voltages.

**56. Three-Phase, Four-Wire System.** Three single-phase units may be used on this system connected between the neutral wire and the outside wires. In such cases, if  $V$  is " $\Delta$ " voltage,  $E$  should be " $\Delta$ " voltage; if  $V$  is  $Y$  voltage,  $E$  should be  $Y$  voltage, and the solution remains the same as for a single-phase system. (Fig. 303.)

Calculations for polyphase regulators are made in the same manner as for the three-phase three-wire system.

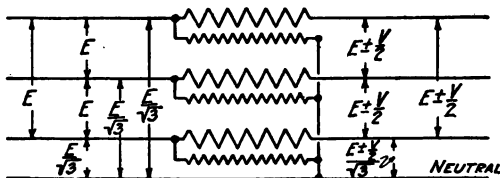

FIG. 303.

### 57. Regulator Capacity.

Let

- $I_0$  = the effective line current.
- kv-a. = kilovolt ampere capacity of regulator.
- $E$  = effective line voltage.
- $e$  = the per cent regulation.

Then

(1) The capacity of a single-phase regulator on a single-phase, or of each of two single-phase regulators on a two-phase system is

$$\text{kv-a.} = \frac{I_0 e E}{10^6}$$



## Sec. 7

## ELECTRICAL CALCULATIONS

(2) The capacity of each of two or three regulators connected to a three-phase, three-wire system, as shown in Figs. 301 and 302, is

$$\text{kv-a.} = \frac{I_0 e E}{10^6}$$

(3) The capacity of each of the single-phase regulators on a three-phase, four-wire system is (Fig. 303)

$$\text{Case (1) kv-a.} = \frac{I_0 E e}{10^6 \sqrt{3}}$$

If E is "Δ" voltage.

$$\text{Case (2) kv-a.} = \frac{I_0 E e}{10^6}$$

If E is Y voltage.

(4) The capacity of a two-phase regulator is

$$\text{kv-a.} = \frac{2 I_0 E e}{10^6}$$

The capacity of a three-phase regulator is

$$\text{Case (1) kv-a.} = \frac{\sqrt{3} I_0 E e}{10^6}$$

If E is the "Δ" voltage, and

$$\text{Case (2) kv-a.} = \frac{3 I_0 E e}{10^6}$$

If E is the Y voltage.

If a transformer is used the per cent increase in voltage is fixed by the ratio of transformation:

Let

$n$  = the ratio of transformation, all other quantities remaining the same as before. The per cent voltage increase is  $e = \frac{100}{n}$

The transformer capacity is found by the following formulae:

$$\text{kv-a.} = \frac{E I_0}{1000 n} = \frac{e E I_0}{10^6}$$

Therefore the formulae used to find regulator capacities may be used for transformers.

**Problem:** The voltage of a 2,200 volt single-phase line varies 110 volts. The line current is 100 amperes. Find the per cent regulation and kv-a. capacity of the regulator required to correct this.

$$e = \frac{110 \times 100}{2 \times 2,200} = 2.5\%$$

$$\text{kv-a.} = \frac{100 \times 2.5 \times 2,200}{10^6} = 5.5 \text{ kv-a.}$$

**58. RESULTANT POWER-FACTORS.** Where several loads of different power-factors are connected to the same feeder, the resultant power-factor may be found by means of the following formulae:

**Symbols:**

- $w_1$  = kilowatts supplied to Load No. 1.
- $\cos. \theta_1$  = power-factor of Load No. 1.
- $w_2$  = kilowatts supplied to Load No. 2.
- $\cos. \theta_2$  = power-factor of Load No. 2.
- $w_3$  = kilowatts supplied to Load No. 3.
- $\cos. \theta_3$  = power-factor of Load No. 3, etc.
- $\cos. \theta_r$  = resultant power-factor.

Then

$$\tan. \theta_r = \frac{w_1 \tan \theta_1 + w_2 \tan \theta_2 + w_3 \tan \theta_3 \text{ etc.}}{w_1 + w_2 + w_3 \text{ etc.}}$$

Find  $\tan \theta_1, \tan \theta_2$  etc. from  $\cos. \theta_1, \cos. \theta_2$  etc. in Sec. 1.

Find  $\cos. \theta_r$  from  $\tan \theta_r$  in Sec. 1.

**Problem:**

Find the combined power-factors of 200 kw. at 70% power-factor, 100 kw. at 80% power-factor, and 50 kw. at 50% power-factor.

$$\cos. \theta_1 = 0.70 \quad \tan. \theta_1 = 1.0176$$

$$\cos. \theta_2 = 0.80 \quad \tan. \theta_2 = 0.75$$

$$\cos. \theta_3 = 0.50 \quad \tan. \theta_3 = 1.732$$

$$\tan. \theta_r = \frac{200 \times 1.0176 + 100 \times 0.75 + 50 \times 1.732}{200 + 100 + 50} = 1.042$$

$$\text{Power-factor} = \cos. \theta_r = 0.692.$$

**59. Power-Factors of Various Types of Loads.** Values in Table 70 have been calculated for various ratios of connected lighting to connected power load. Large and small capacity motors, loaded with an average load of about one-quarter full load and three-quarters full load, have been used. This combination may give much lower or higher power-factors, depending upon the type of machinery used. Motors from  $\frac{1}{4}$  to 3 H.P. are considered small motors, and motors from 5 H.P. to 50 H.P., large motors.

**Symbols.**

$w$  = connected kw. of incandescent lighting.

$w_1$  = connected h.p. of motors  $\times 0.746$

**TABLE 70**  
**POWER-FACTORS**

Relative proportions of lighting to power, connected load	Large motors at $\frac{1}{4}$ load	Large motors at $\frac{1}{2}$ load	Small motors at $\frac{1}{4}$ load	Small motors at $\frac{1}{2}$ load
W = 1 W <sub>1</sub> = 0	1.00	1.00	1.00	1.00
W = .75 W <sub>1</sub> = .25	.99	.98	.97	.96
W = .5 W <sub>1</sub> = .5	.95	.90	.80	.80
W = .25 W <sub>1</sub> = .75	.90	.75	.60	.60
W = 0 W <sub>1</sub> = 1	.85	.40	.70	.35

**60. ECONOMICS OF TRANSMISSION.** Economic conditions cannot be formulated with any great degree of accuracy. In many cases it is necessary to keep down initial expense, even at considerable sacrifice otherwise, or economy in a certain direction may be sought at the expense of economy in some other direction. For these reasons, it is necessary that individual skill and judgment be used. In general, however, use may be made of Kelvin's law: that the greatest economy is obtained where the interest depreciation and taxes on the investment are equal to the cost of the total power losses in the line per year. As the market for power and light is usually uncertain, and the proportion of power to light unknown except within wide limits, the total amount required can only be determined by future conditions. An approximate estimate of the average load, even after the most careful investigation, defies accurate calculation. Thus, the following tables must be used with the utmost care, and are only included herein that they may give, in part, a general idea of the conditions affecting the line itself, but do not include such conditions as cost of right-of-way, cost of the type of structure to be erected, and the many other features which oftentimes influence the location of the line and the investment that can be made in conductors.

**Symbols:**

- $w_m$  = weight of conductor in lbs. per cir. mil foot.
- $\rho$  = resistance per cir. mil foot.
- $a$  = area of conductor in cir. mils.
- $n$  = ratio of total power loss to loss in one wire of system used.

**TABLE 71**  
**VALUES OF K,**

Cost of Energy, cents per Kw-hr.	COST OF METAL, CENTS PER POUND										
	10	11	12	13	14	15	16	17	18	19	20
$\frac{1}{4}$	6.32	6.63	6.93	7.2	7.48	7.75	8.00	8.25	8.48	8.71	8.94
$\frac{1}{2}$	4.47	4.69	4.90	5.1	5.29	5.47	5.65	5.83	6.0	6.16	6.32
$\frac{3}{4}$	3.65	3.82	4.00	4.16	4.32	4.47	4.62	4.76	4.90	5.04	5.16
1	3.16	3.32	3.46	3.6	3.74	3.87	4.00	4.12	4.24	4.35	4.47
$1\frac{1}{2}$	2.58	2.70	2.82	2.94	3.05	3.16	3.25	3.36	3.46	3.56	3.65
2	2.24	2.34	2.45	2.55	2.64	2.74	2.82	2.92	3.00	3.08	3.16
$2\frac{1}{2}$	2.00	2.10	2.19	2.28	2.36	2.45	2.52	2.60	2.68	2.76	2.82
3	1.82	1.91	2.00	2.08	2.16	2.24	2.31	2.38	2.44	2.52	2.58

$n_1$  = ratio of total weight of conductors used to weight of one conductor.

$I_0$  = maximum effective load current.

$$c = \frac{I_0}{a}$$

$l$  = length of line in feet.

$c_1$  = cost of conductor per lb.

$c_2$  = cost of energy per kw-hr.

$i$  = interest as a decimal.

$d$  = depreciation as a decimal.

$t$  = taxes as a decimal.

$h$  = number of hours of operation per year.

Considering the load constant the total cost of the kw-hrs. lost per year in cents is

$$\text{Power cost} = \frac{n \rho l I_0^2 h c_2}{1000 a} \quad \text{No. 1}$$

The investment cost per year is

$$\text{Investment cost} = n_1 w_m a l c_1 (i+d+t) \quad \text{No. 2}$$

One and two must be equal according to Kelvin's law

$$\frac{n \rho l I_0^2 h c_2}{1000 a} = n_1 w_m a l c_1 (i+d+t)$$

$$\frac{I_0}{a} = \sqrt{\frac{n_1 w_m c_1 (i+d+t) 1000}{\rho n h c_2}} = \sqrt{\frac{n_1 w_m (i+d+t) 1000}{\rho n h}} \times \sqrt{\frac{c_1}{c_2}}$$

TABLE 72				
VALUES $K_5$ = VALUES IN TABLE $\times \frac{1}{10^6}$				
System	Size of Wires	Copper 20° C.	Copper Clad 40% 20° C.	Alu- minum 20° C.
2 wire D.C.	..	122	74.5	53.
3 wire D.C.	Neutral equal to outside	150	91	65
3 wire D.C.	Neutral one-half outside	137	83	59.5
Single-phase A.C. two- wire	..	122	74.5	53
Single-phase A.C. three- wire	Neutral equal to outside	150	91	65
Single-phase A.C. three- wire	Neutral one-half outside	137	83	59.5
Two-phase three-wire	Common wire equal to outside	106	64.5	46
Two-phase three-wire	Common wire 1.41 times outside	122	74.5	53
Two-phase four-wire	..	122	74.5	53
Two-phase five-wire	Neutral equal to outside	137	83	59.5
Two-phase five-wire	Neutral one-half outside	130	79	56.5
Three-phase three-wire	..	122	74.5	53
Three-phase four-wire	Neutral equal to outside	141	96	61.5
Three-phase four-wire	Neutral one-half outside	123	80.5	57.5

$$K_4 = \sqrt{\frac{c_1}{c_2}}$$

$$K_5 = \sqrt{\frac{n_1 w_m c_1 (i+d+t) 1000}{\rho n h}}$$

$$c = \frac{I_0}{a} = K_4 K_5$$

The above formulae indicate that the current density in amperes per circular mil area is proportional to the square root of a factor depending upon the number of wires, the weight and resistance per mil foot, the number of hours used and the interest depreciation and tax cost times the square root of the ratio of the cost of material to the cost per kw-hr. of energy. In Table 71 values of  $K_4$  have been calculated for various costs of metal and costs per kw-hr. To extend this table for costs twice as great as those given in the table, multiply the values in the table by 1.41. This will extend costs up to 40 cents per pound. The cost per kw-hr. may be ex-

tended to twice the values in the table by dividing by 1.41, or if the cost per kw-hr. and per pound of material are both doubled, the values will be the same as that given in the table, i.e. cost of material, 32 cents; cost per kw-hr. 6 cents. The ratio of 32 to 6 is the same as the ratio of 16 to 3, therefore  $K_4 = 2.31$ .

In Table 72, the values of  $K_3$  have been calculated for copper, 40% copper-covered steel, and for aluminum, for the different systems enumerated. They are based on an interest rate of 6%, depreciation rate of 5%, tax rate of  $1\frac{1}{2}\%$ ; and for a continuous use of energy for 300 days at 8 hours per day, and they give a general indication of the economic current density. However, it is better if possible to obtain the square root of the mean square load current over the total time of operation.

$I_0$  divided by this effective current =  $c_3$ .

Then

$$c = \frac{I_0}{a} = c_3 K_3 K_4$$

**61. TRANSPOSITIONS.** The transposition of overhead lines is a means of eliminating mutual inductance between two circuits and of balancing the self-inductances of unsymmetrically spaced

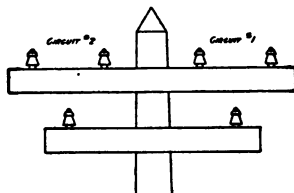

Fig. 304.

lines. Fig. 304 shows a three-phase circuit in which no transposition is necessary to equalize the self-inductance of the wires. Fig. 305 shows a three-phase circuit in which it is necessary to transpose the wires as shown in Fig. 306 in order to equalize the self-inductive effect in each wire.

In calculating the inductance and capacity when the wires are transposed as shown in Fig. 306 it is necessary to use the separation between adjacent wires for two thirds, and between outside wires for the remaining one-third of the length of the line. With the average separation so determined and substituted in the formulae or table, the proper value for the capacity or inductance is obtained. It has also been shown that the geometric mean of these three distances will give a value that may be used in finding inductance and capacity.

Sec. 7 **ELECTRICAL CALCULATIONS**

In Fig. 306

$d_1 = 12$  inches.

$d_2 = 24$  inches.

Then by the first method  $d_r = \frac{2 \times 12 + 24}{3} = 16$

By the second method  $d_r = \sqrt{12 \times 12 \times 24} = 15.1$

The first method has been longer in use. The second method is practically new and was formulated by J. G. Pertsch, Jr.

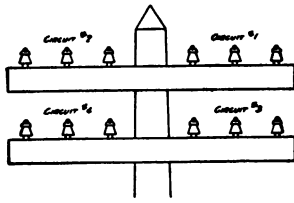

FIG. 305.

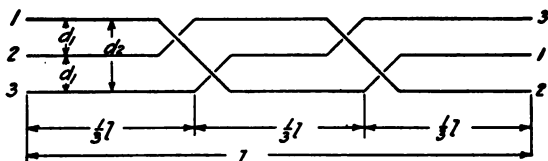
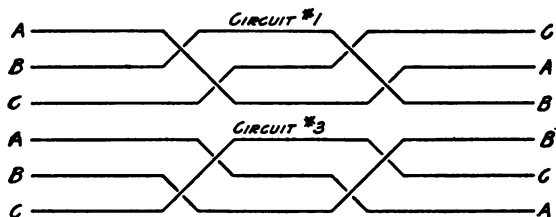

FIG. 306.



[FIG. 307.]

In Fig. 305 it is unnecessary to transpose the circuits to avoid mutual inductance if Circuits 1 and 2 only are considered. With Circuits 1 and 3, however, there must be a transposition to prevent the effect of mutual inductance. Fig. 307 indicates how this may be accomplished.

With two-phase circuits as shown in Fig. 308 the arrangement for Circuit No. 1 has no mutual inductance between the phases. The arrangement for Circuit No. 2 will give mutual inductance between phases and to annul this must be transposed as shown in Fig. 309. In Circuit No. 3 there is practically no mutual inductance between the A and B phase, but there is mutual inductance between the A phases of Circuits 3 and 4, and the B phases of Circuits 3 and 4; and each phase of one circuit must be transposed as shown in Fig. 310 to annul mutual inductance. Transpositions must be

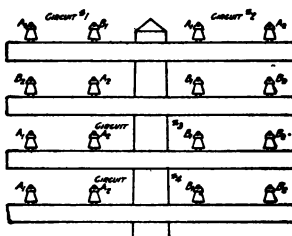

FIG. 308

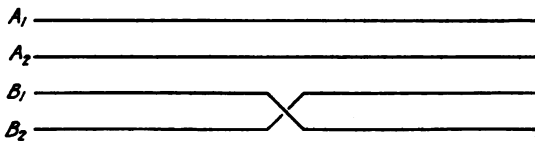

FIG. 309

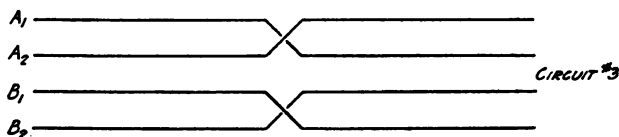

FIG. 310

made between the generating station and any important load if it is desired to accurately balance inductive effects.

Transpositions are seldom necessary in distribution work as the amount of current is too small and the lengths of line too short to disturb the voltage relations.

**62. CONSTANT VOLTAGE TRANSMISSION.** Due to the necessity of spacing wires far apart on high voltage long distance



## Sec. 7

## ELECTRICAL CALCULATIONS

transmission lines, the reactance is consequently very large. To transmit a large load and preserve commercial regulation, it is necessary to have a comparatively large number of parallel lines. To overcome this difficulty and reduce the cost of transmission, a method is used consisting of the installation of synchronous machinery at the receiving end, controlled by automatic voltage relays in such manner that they operate to vary the power-factor of the line with variation in load, and counteract the voltage drop due to the load

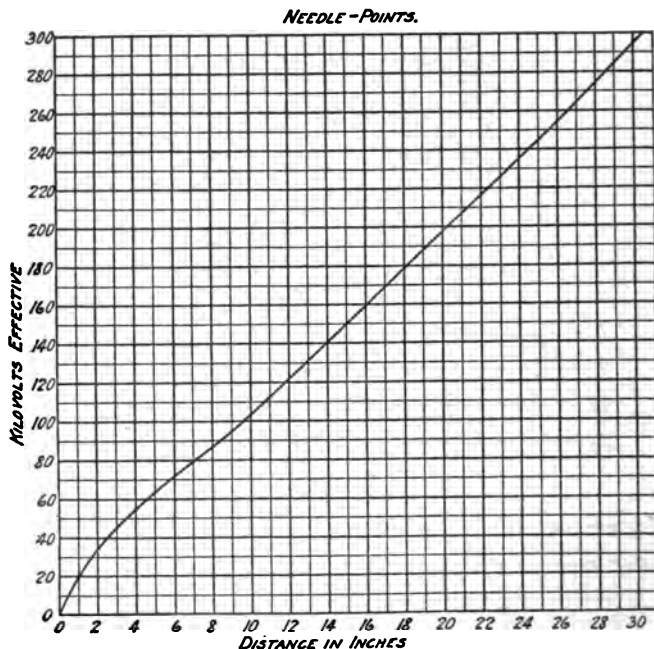

Fig. 311.

current flowing through the reactance and resistance of the transmission line. Installations of this type have already been installed and are being operated very successfully.

### 63. SPARKING DISTANCES:

**Needle Gaps.** There are many factors affecting the discharge voltages of a needle gap with a given separation of needle points.

- (1) Air density.
- (2) Humidity.
- (3) Sharpness of the needles.
- (4) Location of the gap with respect to surrounding bodies.
- (5) Size and proximity of the needle supports.

The sparking distances in inches and centimeters in air between Sharp No. 6 opposed needle points for various effective sinusoidal voltages are given in Table 73 and Fig. 311.

This table and curve are approximately correct for the following conditions:

A barometric pressure of 29.92 inches of mercury, a temperature of 77° F. and about (75-80) per cent humidity, which are average conditions.

A non-inductive resistance of about  $\frac{1}{2}$  to 4 ohms per volt should be inserted in series with the gap.

No extraneous body should be nearer the gap than a radius of twice the gap length. It is not good practice to use the needle gap for voltages above 100 kv.

The Sphere Gap, discharge voltage is affected by fewer variables than the needle gap.

TABLE 73					
SPARKING DISTANCES					
NEEDLE POINTS					
Kilovolts R. M. S.	DISTANCE		Kilovolts R. M. S.	DISTANCE	
	Inches	Cm.		Inches	Cm.
5	0.225	0.57	140	13.95	35.4
10	0.47	1.19	150	15.0	38.1
15	0.725	1.84	160	16.05	40.7
20	1.0	2.54	170	17.10	43.4
25	1.3	3.3	180	18.15	46.1
30	1.625	4.1	190	19.20	48.8
35	2.0	5.1	200	20.25	51.4
40	2.45	6.2	210	21.30	54.1
45	2.95	7.5	220	22.35	56.8
50	3.55	9.0	230	23.40	59.4
60	4.65	11.8	240	24.45	62.1
70	5.85	14.9	250	25.50	64.7
80	7.1	18.0	260	26.50	67.3
90	8.35	21.2	270	27.50	69.8
100	9.6	24.4	280	28.50	72.4
110	10.75	27.3	290	29.50	74.9
120	11.85	30.1	300	30.50	77.4
130	12.90	32.8			

## Sec. 7 ELECTRICAL CALCULATIONS

- (1) Air density.
- (2) Location of the gap with respect to surrounding bodies.
- (3) Size of the gap supports.

In spheres larger than 10 cm. in diameter the third item noted above is practically negligible.

The sparking distances in inches and centimeters in air between different size spheres for various effective sinusoidal voltages will be found in Tables 74 to 76 and Figs. 312 and 313.

These tables and curves are correct for a barometric pressure of 29.92 inches of mercury and a temperature of 77° F. No data are at present available for sphere gap corrections, but at or near sea level, corrections for variation in barometric pressure and temperature may be made by multiplying the values in the table by

$$\frac{17.91 b}{459 + t}$$

in which  $b$  = barometric pressure in inches of mercury.  
and  $t$  = temperature in degrees fahrenheit.

A non-inductive resistance of about  $\frac{1}{2}$  to 4 ohms per volt should be inserted in series with the gap. No extraneous body should be nearer the gap than a radius of twice the gap length. It has been suggested that for most commercial testing, needle gaps may be used up to about 60,000 volts and sphere gaps from about 50,000 up to the highest voltages now used.

TABLE 74			
SPHERE GAP SPARK-OVER VOLTAGES			
12.5 cm. SPHERES			
[SPACING		KILOVOLTS EFFECTIVE	
Cm.	In.	Non-Grounded	Grounded
0.25	0.098	6.5	6.5
0.50	0.197	12	12
1	0.394	22	22
1.5	0.591	31.5	31.5
2	0.787	41	41
3	1.181	59	59
4	1.575	76	76
5	1.969	91	89
6	2.362	106	102
7	2.756	118	112
8	3.150	130	120
9	3.543	141	128
10	3.937	151	135
12	4.72	167	147
15	5.91	188	160
17.5	6.88	201	168
20	7.87	218	174

**TABLE 75**  
**SPHERE GAP SPARK-OVER VOLTAGES**  
**25 cm. SPHERE**

SPACING		KILOVOLTS EFFECTIVE	
Cm.	In.	Non-Grounded	Grounded
0.5	0.197	11	11
1	0.394	22	22
1.5	0.591	33	32
2	0.787	42	42
2.5	0.983	52	52
3	1.181	61	61
4	1.575	78	78
5	1.969	96	94
6	2.362	112	110
7.5	2.953	135	132
10	3.937	171	166
12.5	4.92	203	196
15	5.91	230	220
17.5	6.88	255	238
20	7.87	278	254
22.5	8.85	297	278
25	9.83	314	290
30	11.81	339	300
40	15.75	385	325

**TABLE 76**  
**SPHERE GAP SPARK-OVER VOLTAGES**  
**50 cm. SPHERES**

SPACING		KILOVOLTS EFFECTIVE
Cm.	In.	Grounded Values
2	0.787	40
4	1.575	78
6	2.362	112
8	3.150	145
10	3.937	185
12	4.72	220
14	5.50	250
16	6.28	275
18	7.07	300
20	7.87	320
22	8.65	345

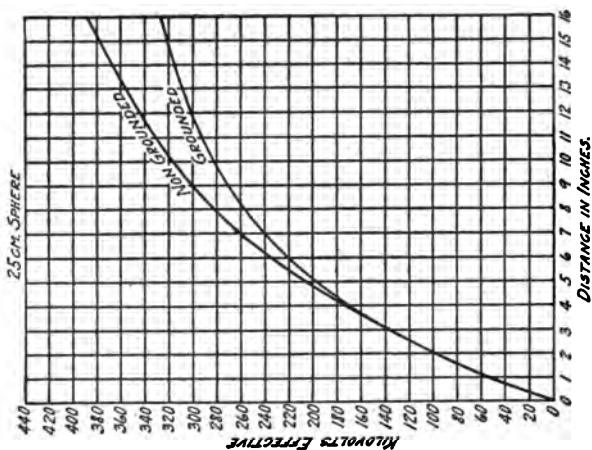

Fig. 313.

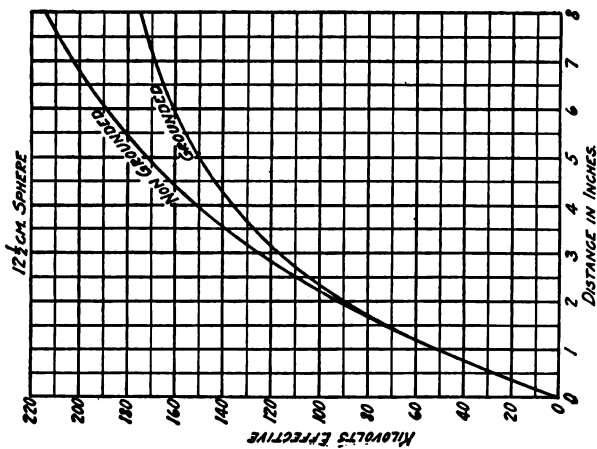

Fig. 312.

## BIBLIOGRAPHY

- American Electrician's Handbook.  
Foster's Electrical Engineer's Pocketbook.  
Standard Handbook for Electrical Engineers.  
Electrical Appendix D'Este's Steam Engineer's Manual.  
Franklin & Williamson's Alternating Current.  
Calculations of Alternating Current Problems. (Cohen.)  
Overhead Electric Power Transmission. (Still.)  
Proceedings A. I. E. E.  
Corona F. W. Peek, Jr., July 1911, June 1912, June 1913.  
Transmission Calculation.  
Transmission Calculation (Pender), June 1908, July 1911.  
Transmission Calculation (Thomas), June 1909.  
Transmission Calculation (Kennelly), Dec. 1911, June 1912.  
Transmission Calculation (Dwight), June 1913.  
U. S. Weather Bureau.  
Electric Journal, 1905, 1906.  
General Electric Review, 1912.  
General Electric Review, 1913.



## **SECTION 8**

### **MECHANICAL CALCULATION OF TRANSMISSION AND DISTRIBUTION LINES**





## SECTION 8

### MECHANICAL CALCULATIONS OF TRANSMISSION AND DISTRIBUTION LINES

---

#### TABLE OF CONTENTS

	ARTICLE
<b>General</b> .....	1
<b>Fundamental formulæ</b>	
Wind pressure.....	2
Compression and tension.....	3
Shearing stress.....	4
Bending moment.....	5
Torsion.....	6
<b>Strength of timber</b> .....	Table 77
<b>Moment of inertia and section modulus</b> .....	Table 78
<b>Bending moment</b> .....	Table 79
<b>Solution of sag problems</b>	
General.....	7
Weight of wire.....	8
Weight of wire and ice.....	9
Wind pressure.....	10
Resultant load of ice and wind pressure.....	11
Temperature changes.....	12
Symbols and formulæ.....	13
Problems.....	14
Loading, sag and length Tables	
<b>Cross-arms</b>	
General.....	15
Bending moment due to weight of wires.....	16
Bending moment due to unbalance tension in wires.....	17
<b>Pole stresses</b> .....	18
Wind pressure on pole and conductor.....	19
Dead end loading.....	20
Bends in line.....	21
<b>Guying</b> .....	22
<b>Concrete and Steel Structures</b> .....	23



1. **GENERAL.** The mechanical problems met with in the design of a transmission line can in general be divided into two classes:

(a) Stresses incident to the plan of a line.

(b) Stresses which occur due to changes in temperature and to abnormal weather conditions.

The stresses incident to the design of a line are those which occur at dead ends and at bends in the line.

The stresses which occur due to changes in temperature and to wind and ice loads must be assumed and vary with local conditions.

The solutions of the mechanical problems involved entail the application of fundamental formulæ which formulæ are listed below.

The problems solved herein have been calculated on the slide rule wherever possible, which method is suggested as being sufficiently accurate since variations in material will more than offset any error incident to slide rule calculation.

## FUNDAMENTAL FORMULÆ

### 2. Wind Pressure Formulæ.

V = actual velocity of wind in miles per hour.

F = pressure in pounds per square foot.

B = barometric pressure in inches.

Then for small flat surfaces.

$$F = 0.004 \times \frac{B}{30} \times V^2$$

For the projected surface of a cylinder (diameter  $\times$  length).

$$F = 0.0025 V^2$$

### 3. Compression and Tension Formulæ.

s = tension or compression stress in pounds per square inch.  
a = area in square inches at right angle to the direction of the force producing the stress.

W<sub>t</sub> = total weight or force in pounds producing tension or compression stresses.

$$s = \frac{W_t}{a}$$

### 4. Shearing Stress Formula.

s = shearing stress in fibre in pounds per square inch.

a = area in square inches parallel to shearing force.

W<sub>t</sub> = total weight or force in pounds producing shear.

$$\text{Then } s = \frac{W_t}{a}$$

### 5. Bending Moment Formulæ.

M = bending moment in pound-inches.

s = maximum fibre stress per square inch.

## Sec. 8 MECHANICAL CALCULATIONS

- c** = distance from neutral axis to point of maximum fibre stress.  
**I** = moment of inertia.  
**Q** = section modulus.

$$M = \frac{s I}{c} = s Q$$

### 6. Torsion Formulae.

- M<sub>t</sub>** = torsion moment in pound-inches.  
**s** = maximum shearing stress per square inch.  
**c** = distance in inches from neutral axis to point of maximum fibre stress.  
**J** = polar moment of inertia.  
**I<sub>1</sub>** = least rectangular moment of inertia about two axes passing through the centre.  
**I<sub>2</sub>** = greatest rectangular moment of inertia about two axes passing through the centre.

$$M_t = \frac{s J}{c}$$

$$J = I_1 + I_2$$

### 7. SOLUTION OF SAG PROBLEMS.







The sag necessary in any span is dependent upon the following:

- a. The character and size of the conductor (Art. 8).

TABLE 77 STRENGTH OF TIMBER In lbs. per sq. in.		
Untreated Timber	Bending	Compression
Port Orford Cedar.....	6300	$(6300 \ 1 - \frac{L}{60 D})$
Long Leaf Yellow Pine.....	6000	6000 "
White Oak.....	5700	5700 "
Douglas Fir.....	5400	5400 "
Chestnut.....	5100	5100 "
Washington Cedar.....	5100	5100 "
Idaho Cedar.....	5100	5100 "
Short Leaf Yellow Pine.....	4800	4800 "
Bald Cypress (heartwood).....	4800	4800 "
Red Cedar.....	4200	4200 "
Redwood.....	3900	3900 "
Eastern White Cedar.....	3600	3600 "
Juniper.....	3300	3300 "
Catalpa.....	3000	3000 "



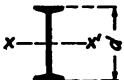
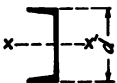

L = Length in inches.  
 D = Least side, or diameter, in inches.

TABLE 78

Shape of Section	Moment of Inertia $I$	Section Modulus $Q$	Sq. Least Radius of Gyration $R^2$
	$\frac{d^4}{12}$	$\frac{d^3}{6}$	$\frac{d^2}{12}$
	$\frac{bd^3}{12}$	$\frac{bd^2}{6}$	$\frac{b^3}{12}$
	$\frac{b^4 - b'^4}{12}$	$\frac{I}{.5b}$	$\frac{b^2 + b'^2}{12}$
	$\frac{bd^3 - b'd'^3}{12}$	$\frac{I}{.5d}$	$\frac{I}{A}$
	$\frac{\pi d^4}{64}$ , or $.0491d^4$	$\frac{\pi d^3}{32}$ , or $.0982d^3$	$\frac{d^2}{16}$
	$.0491(d^4 - d'^4)$	$.0982\left(d^3 - \frac{d'^4}{d}\right)$	$\frac{d^2 + d'^2}{16}$
	$\frac{bd^3 - 2b'd'^3}{12}$	$\frac{I}{0.5d}$	$\frac{I}{A}$
	$\frac{Ad^3}{6.66}$ (Approx.)	$\frac{Ad}{3.2}$ (Approx.)	$\frac{I}{A}$
	$\frac{Ad^3}{7.34}$ (Approx.)	$\frac{Ad}{3.67}$ (Approx.)	$\frac{I}{A}$

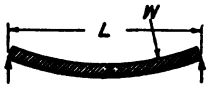
NOTE.— $A$ —total area of section. In calculating the least radius of gyration be sure to use the least moment of inertia.  $x-x'$  denotes the neutral axis, and the value of  $I$  given is that about this axis.

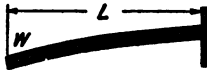
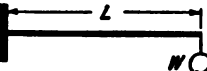
TABLE 79

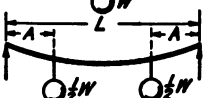
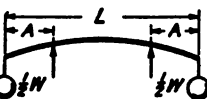
Method of Loading		Maximum Bending Moment <i>M</i> .		Maximum Load <i>W</i>	Deflection <i>D</i> .
Length in Feet	Load in Pounds	Ft.-Lb.	In.-Lb.	Lb.	In.
		$\frac{W L}{8}$	$\frac{3 W L}{2}$	$\frac{2 Q S}{3 L}$	$\frac{5 W F^3}{384 E I}$
		$\frac{W L}{6}$	$2 W L$	$\frac{Q S}{2 L}$	$\frac{W F^3}{60 E I}$
		$\frac{W L}{2}$	$6 W L$	$\frac{Q S}{6 L}$	$\frac{W F^3}{8 E I}$
		$W L$	$12 W L$	$\frac{Q S}{12 L}$	$\frac{W F^3}{3 E I}$
		$\frac{W L}{4}$	$3 W L$	$\frac{Q S}{3 L}$	$\frac{W F^3}{48 E I}$
		$\frac{W A}{2}$	$6 W A$	$\frac{Q S}{6 A}$	$\frac{W a}{48 E I} \times$ $(3 l^2 - 4 a^2)$ Between Supports.
		$\frac{W A}{2}$	$6 W A$	$\frac{Q S}{6 A}$	$\frac{W a}{16 E I} \times$ $(l - 2 a)^2$

*L*—length in feet; *l*—length in inches; *W*—total load in pounds; *E*—modulus of elasticity; *I*—moment of inertia; *Q*—section modulus; *S*—safe stress on the extreme fibres of the beam section (= modulus of rupture ÷ factor of safety). In figuring deflections, all lengths must be expressed in inches; and small letters *l*, *a*, and *b* are used as reminders.

b. The maximum load to which it will be subjected (Art. 9, 10, 11).

(Weight of wire plus ice and wind load.)

c. Maximum variation in temperature (Art. 12).

8. The Weight of the Wire depends upon—

The material.

The area of cross-section.

Whether solid or stranded.

Whether insulated or bare.

The weight of conductor per foot may be found in Tables 80 to 85, Sec. 8, and per 1000 feet in Tables 33 and 34, Sec. 3.

9. Weight of Wire and Ice. (Tables 80 to 85.)

d = diameter of wire in inches.

t = thickness of ice in inches (assuming a cylindrical formation).

W = weight of wire in pounds per foot.

$W_t$  = total weight of wire and ice in pounds per foot of conductor (assuming ice weighs 57.2 lbs. per cu. ft.).

$$W_t = W + 1.248 (dt + t^3).$$

10. Wind Pressure on Wires. (Tables 80 to 85.)

F = wind pressure in pounds per square foot.

d = diameter of wire in inches.

t = thickness of ice in inches.

$F_o$  = force in pounds per foot length of wire.

For wire alone

$$F_o = \frac{F d}{12}$$

For wire and ice

$$F_o = \frac{F (d + 2t)}{12}$$

11. Total Resultant Load produced by the weight of the wire plus the wind and ice loads.

$F_o$  = horizontal force in pounds per foot length of wire.

$W_t$  = the total weight or the vertical force in pounds per foot length of wire.

$$W_1 = \sqrt{F_o^2 + W_t^2}$$

This may also be solved trigonometrically (Fig. 314) as follows:

$$W_1 = \frac{W_t}{\cos. \alpha}$$

$$\text{Tan. } \alpha = \frac{F_o}{W_t}$$

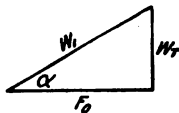

FIG. 314.



## Sec. 8

## MECHANICAL CALCULATIONS

**12. Temperature Changes.** Changes in temperature affect the solution of the sag problems in that the total length of wire, and therefore the sag increases and decreases with increasing and decreasing temperature.

**13. Symbols and Formulæ.** The resultant sag is determined by combining all the above factors in one solution, the formulæ for which follow:

These formulæ in connection with the curves in Figs. 318 to 320 may be used to solve the mechanical problems met with in the stringing of conductors.

The curves Figs. 318 to 320 are illustrated on a very small scale and for calculations should be increased in size.

The data necessary for the preparation of these curves are given in Table 86, from which table curves of sufficient size to obtain accurate results may be plotted.

D = distance in feet between supports.

d = sag in feet at stringing temperature "t."

t = stringing temperature in Degrees F.

T = total tension in the wire in pounds at temperature "t."

s = stress per square inch at tension "T."

a = effective area of wire in square inches.

W = weight per foot of wire.

d<sub>1</sub> = sag in feet at desired change in temperature or temperature at maximum stress.

t<sub>1</sub> = temperature at which stress is desired, or temperature at maximum stress.

T<sub>1</sub> = tension in wire in pounds at temperature t<sub>1</sub>.

s<sub>1</sub> = stress per square inch at tension T<sub>1</sub>.

W<sub>1</sub> = weight of loaded wire (includes ice load or ice and wind load).

α = co-efficient of linear expansion per degree F.

E = modulus of elasticity.

$$l = \frac{\text{length of wire at temp. } (t)}{D}$$

$$l_1 = \frac{\text{length of wire at temp. } (t_1)}{D}$$

$$l_0 = \frac{\text{unstressed length of wire at temp. } (t)}{D}$$

$$l'_0 = \frac{\text{unstressed length of wire at temp. } (t_1)}{D}$$

$$\lambda = \frac{d}{D}$$

$$\lambda_1 = \frac{d_1}{D}$$

$$K = \frac{s a}{W D}$$

$$K_1 = \frac{s_1 a}{W D} \text{ for change in temperature only.}$$

$$K_1 = \frac{s_1 a}{W_1 D} \text{ for change in temperature and in load.}$$

$$T = s a$$

$$T_1 = s_1 a$$

When wire loading is unchanged, but temperature is changed.  
Then

$$l_0 = l - \frac{s}{E}$$

$$l_0' = l_0 - \alpha (t - t_1)$$

When conditions are given at heavy loading in order to find conditions at light loading.

$$l_0' = l_1 - \frac{s_1}{E}$$

$$l' = l_1 - \frac{s_1}{E} \left( 1 - \frac{W}{W_1} \right)$$

$$l_0 = l_0' + \alpha (t - t_1)$$

When conditions are given at light loading in order to find conditions at heavy loading.

$$l_0 = l - \frac{s}{E}$$

$$l' = l + \frac{s}{E} \left( \frac{W_1}{W} - 1 \right)$$

$$l_0' = l_0 - \alpha (t - t_1)$$

When the supports for the wire are at different levels, the distance from the higher support to the lowest point of the wire in the span is determined and the problem solved for a span twice the length of the distance so determined.

$x_1$  = distance in feet from the lowest point in the span to the higher support.

$h$  = difference in level in feet between the wire supports.

$d$  = sag in feet measured from the higher support.

$D$  = the horizontal distance in feet between wire supports.

$$x_1 = \frac{D}{2} + \frac{h s a}{D W} = \frac{D}{2} + K h$$

also

$$x_1 = D \frac{\sqrt{d}}{\sqrt{d-h} + \sqrt{d}}$$

When  $x_1$  has been determined, solve the problem as though for level wire supports, but for a length of span equal to the corrected length  $D_1$ , where

$$D_1 = 2x_1$$

#### 14. PROBLEMS:

**Problem 1.** Determine the change in the sag and in the tension of the conductor due to a drop in temperature to  $10^\circ$  F. when strung under the following conditions:

Length of span 200 feet.

Sag at stringing temperature 1.5 feet.

Stringing temperature  $70^\circ$  F.

Conductor—Bare, Hard drawn, Stranded No. 00 Copper wire.

$$D = 200 \text{ feet.}$$

$$d = 1.5 \text{ feet.}$$

$$t = 70^\circ \text{ F.}$$

$$t_1 = 10^\circ \text{ F.}$$

$$W = 0.406. \text{ (From Table 82.)}$$

$$a = 0.1045. \text{ (From Table 82.)}$$

$$E = 16,000,000. \text{ (From Table 81.)}$$

$$\alpha = 0.0000096. \text{ (From Table 81.)}$$

**Solution:**

$$\lambda = \frac{d}{D} = \frac{1.5}{200} = 0.0075$$

In Fig. 315 lay off  $\lambda$  a parallel to  $oy$ . Draw  $Kc$  parallel to  $ox$  and through the intersection  $b$  of  $\lambda a$  and the sag curve.

Drop a perpendicular line  $dl$  from the intersection  $d$  of  $Kc$  and the length curve.

$$K = 16.3$$

$$l = 1.000156$$

$$s = \frac{KW D}{a} = \frac{16.3 \times 0.406 \times 200}{0.1045} = 12,600 \text{ lbs. per sq. inch.}$$

$$l_0 = l - \frac{s}{E} = 1.000156 - \frac{12,660}{16,000,000} = 0.9993645$$

Lay off the difference between  $l$  and  $l_0$  (Fig. 315)  $= 1 - 0.9993645 = 0.0006355$ , from  $O$ .

Draw a line from  $l_0$  through  $d$ .

$$l_0' = l_0 - \alpha (t - t_1)$$

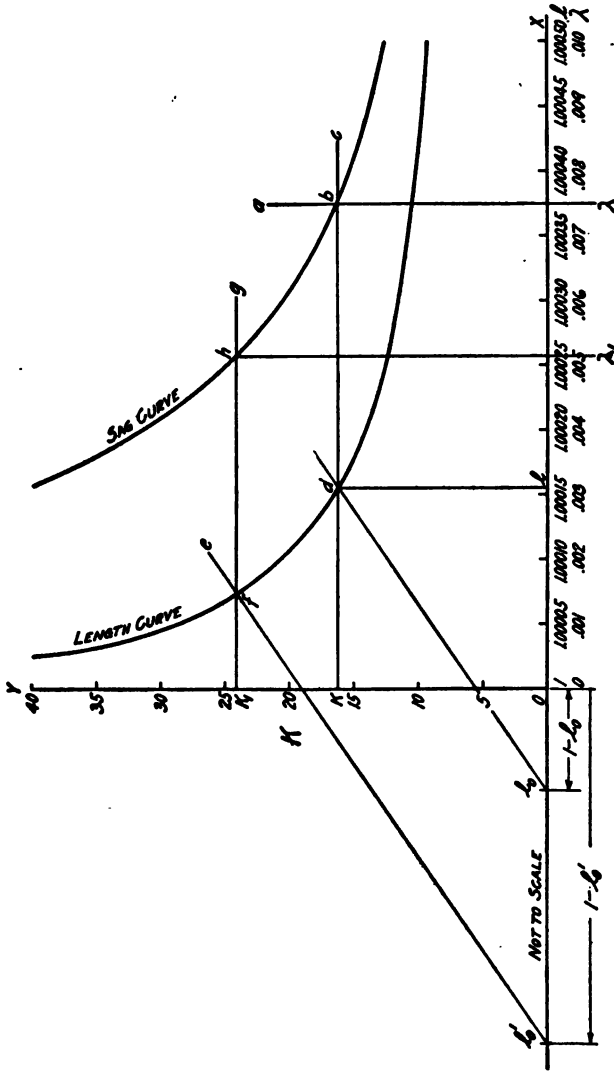

FIG. 316.

## Sec. 8

## MECHANICAL CALCULATIONS

$$l_0' = 0.9993645 - 0.0000096 (70 - 10)$$

$$l_0' = 0.9993645 - 0.000576 = 0.9987885$$

Lay off the difference between 1 and  $l_0'$ ,  $= 1 - 0.9987885 = 0.0012115$  from O and draw  $l_0 e$  parallel to  $l_0 d$  intersecting the length curve at f. Draw  $K_1 g$  through f parallel to  $ox$  and where it intersects the sag curve h, drop a perpendicular  $\lambda_1 h$

Then

$$K_1 = 24.3$$

$$\lambda_1 = 0.0051$$

From which

$$T_1 = K_1 W D = 24.3 \times 0.406 \times 200 = 1,975 \text{ lbs.}$$

$$s_1 = \frac{K_1 W D}{a} = \frac{24.3 \times 0.406 \times 200}{0.1045} = 18,900 \text{ lbs per sq. in.}$$

$$d_1 = \lambda_1 D = 0.0051 \times 200 = 1.02 \text{ feet.}$$

$$d_1 = 1.02 \times 12 = 12.24 \text{ inches.}$$

**Problem 2.** Determine the sag and the tension of the conductor when strung at a temperature of  $70^\circ \text{ F.}$ , so that when subjected to a temperature of  $0^\circ \text{ F.}$  and the additional load of  $\frac{1}{2}''$  of sleet, and a wind pressure of 8 lbs. per square foot, the stress in the conductor will be within 17,000 lbs. per square inch, for the following structural conditions:

Length of span 200 feet.

Conductor—Triple Braid Weatherproof, soft drawn solid No. 00 copper wire.

$$D = 200 \text{ feet.}$$

$$t = 70^\circ \text{ F.}$$

$$t_1 = 0^\circ \text{ F.}$$

$$W_1 = 1.518. \quad (\text{Table 84.})$$

$$W = 0.502. \quad (\text{Table 84.})$$

$$a = 0.1045. \quad (\text{Table 84.})$$

$$E = 12,000,000. \quad (\text{Table 81.})$$

$$\alpha = 0.0000096. \quad (\text{Table 81.})$$

$$s = 17,000 \text{ lbs.}$$

**Solution :**

$$K_1 = \frac{s_1 a}{W_1 D} = \frac{17,000 \times 0.1045}{1.518 \times 200} = 5.85$$

In Fig. 316 draw  $K_1 a$  parallel to  $ox$ , where this line intersects the length curve at a drop a perpendicular line  $a l_1$  and obtain  $l_1$

$$l_1 = 1.001225$$

$$l_0' = l_1 - \frac{s_1}{E} = 1.001225 - \frac{17,000}{12,000,000}$$

$$l_0' = 0.999809.$$

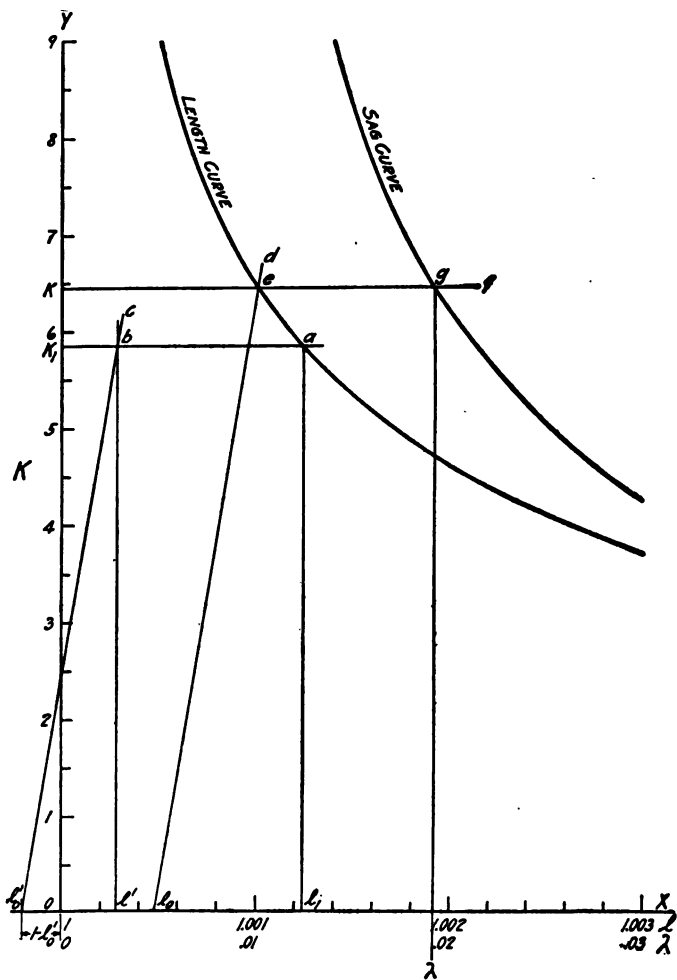

FIG. 316

## Sec. 8

## MECHANICAL CALCULATIONS

Lay off the difference between 1 and  $l'_o = 1 - 0.999809 = 0.000191$  from 0.

$$l' = l_1 - \frac{s_1}{E} \left( 1 - \frac{W}{W_1} \right) = 1.001225 - \frac{17,000 \left( 1 - \frac{0.502}{1.518} \right)}{12,000,000}$$

$$l' = 1.000279$$

Lay off  $l'$  from 0 and erect a perpendicular intersecting  $K_1 a$  at b, draw  $l'_oc$  through  $l'_o$  and b.

$$l_o = l'_o + a(t - t_1)$$

$$l_o = 0.999809 + 0.0000096 (70 - 0) = 0.999809 + 0.000672$$

$$l_o = 1.000481$$

Lay off  $l_o$  from 0 and draw  $l_od$  parallel to  $l'_oc$  intersecting the length curve at c. Draw  $Kf$  parallel to  $ox$  through e and where  $Kf$  intersects the sag curve at g, drop a perpendicular  $g\lambda$ .

$$\lambda = .0194$$

$$K = 6.475$$

$$d = \lambda D = 0.0194 \times 200 = 3.88 \text{ ft.}$$

$$d = 3.88 \times 12 = 46.56 \text{ inches}$$

$$T = K W D = 6.475 \times 0.502 \times 200 = 650 \text{ lbs.}$$

$$s = \frac{K W D}{a} = \frac{650}{0.1045} = 6210 \text{ lbs. per square inch.}$$

**Problem 3.** Determine the sag and tension of a conductor at  $10^\circ$  F. when loaded with  $\frac{1}{2}$ " of sleet and a wind pressure of 8 lbs. per square foot for the following structural conditions.

Length of spans 200 feet.

Conductor—Bare, stranded No. 00 aluminum wire.

Stringing temperature  $70^\circ$  F.

Sag 4.5 feet.

$$D = 200 \text{ feet.}$$

$$d = 4.5 \text{ feet.}$$

$$t = 70^\circ \text{ F.}$$

$$t_1 = 10^\circ \text{ F.}$$

$$W = 0.122. \text{ (From Table 85.)}$$

$$W_1 = 1.168. \text{ (From Table 85.)}$$

$$a = 0.1045. \text{ (From Table 85.)}$$

$$E = 9,000,000. \text{ (From Table 81.)}$$

$$\alpha = 0.0000128. \text{ (From Table 81.)}$$

**Solution:**

$$\lambda = \frac{d}{D} = \frac{4.5}{200} = 0.0225$$

*Continued on page 545.*

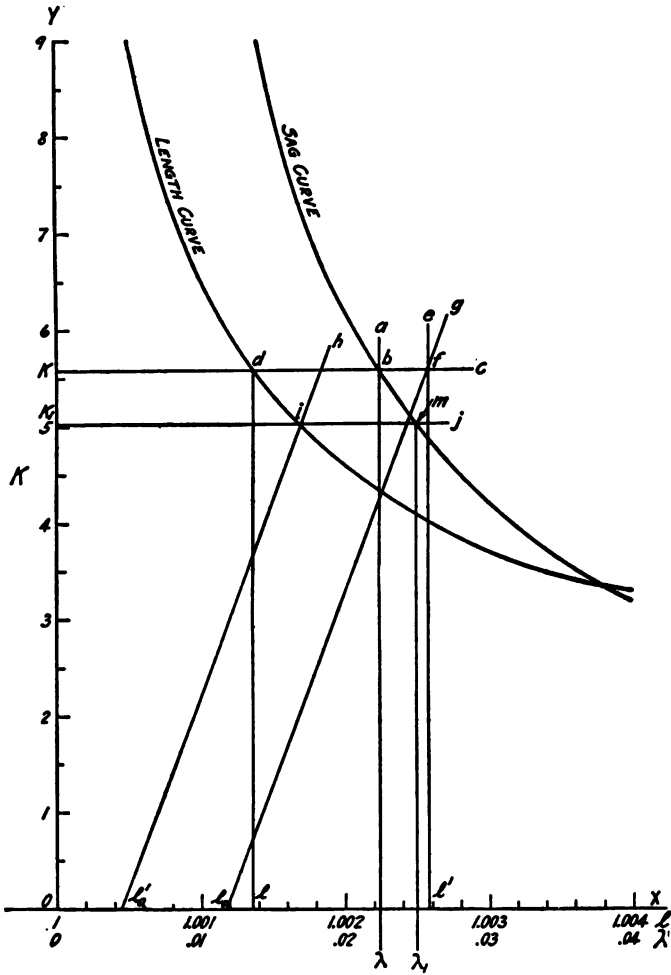

FIG. 317.



TABLE 80  
STEEL WIRE—STRANDED—GALVANIZED\*

Diam.	Number and Gauge of Wires	Area Square Inches	ULTIMATE STRENGTH				LOAD PER LIN. FT. VERTICAL		LOAD PER LIN. FT. HORIZONTAL	Max. Load Per Lin. Ft. Resultant Class B Loading	EA E=29,000,000
			Guy Wire	Siemens Martin 75,000 lb	High Tension 125,000 lb	Ex. High Tension 187,000 lb	Dead	Dead + 1/2 Ice			
3/8"	..	..	..	..	..	..	..	1.250	..	..	
1/2"	..	..	..	..	..	..	..	1.306	..	..	
5/8"	..	..	..	..	..	..	..	1.167	..	..	
1"	..	..	..	..	..	..	..	1.125	..	..	
1 1/4"	7-5	0.3256	19,000	25,000	42,000	..	..	1.083	..	6,822,400	
1 1/2"	7-6 1/2	0.1922	14,500	21,100	34,500	..	0.668	1.329	..	5,575,800	
1 3/4"	7-8	0.1443	11,000	18,000	27,000	8,500	0.510	1.132	1.510	4,194,700	
2"	7-9	0.1204	9,000	15,000	22,500	6,500	0.415	0.998	1.323	3,491,600	
2 1/4"	7-11	0.0832	6,800	11,500	17,250	5,000	0.295	0.839	1.243	2,412,800	
2 3/4"	7-12	0.0606	4,800	8,100	12,100	3,800	0.210	0.715	1.130	1,757,400	

\* Tables 80 to 85 from Overhead Line Committee Report, 1911.

**TABLE 81**  
**PROPERTIES OF WIRE MATERIALS**

Material	Ultimate Strength per Square In.	Elastic Limit	Mod. Elasticity E	Coef. Expansion $\beta$
Copper, solid, soft-drawn.....	32-34,000	28,000	12,000,000	0.0000096
“ “ hard-drawn.....	50-55-57-60,000	30-32-34-35,000	16,000,000	“
“ stranded, soft-drawn.....	34,000	25,000	12,000,000	“
“ “ hard-drawn.....	60,000	35,000	16,000,000	“
Aluminum, stranded.....	23,27,000	14,000	9,000,000	0.0000128
Steel, stranded, Siemens-Martin.....	75,000	..	29,000,000	0.0000064
“ “ high-tension.....	125,000	..	“	“
“ “ ex-high-tension.....	187,000	..	“	“

Note—Class A Loading = dead load + 15.0 lbs. p. sq. ft. wind pressure.  
 Class B “ = dead +  $\frac{1}{2}$ " ice + 8.0 lbs. wind.  
 Class C “ = dead +  $\frac{3}{4}$ " ice + 11.0 lbs. wind.

TABLE 82  
COPPER WIRE—STRANDED—BARE

Gauge B. & S.	Diam. Inches	Area Sq. In.	HARD DRAWN Tension Lbs.	SOFT DRAWN Ult. Tens'n Lbs.	LOAD PER LIN. FOOT VERTICAL			LOAD PER LIN. FOOT HORIZONTAL			MAX. LOAD PER LIN. FOOT PLANE OF RESULTANT			EA	
					Dead 1/2 Ice	Dead 1/4 Ice	Dead 1/8 Ice	15.0 lb P. Sq. Ft.	8.0 lb P. Sq. Ft.	11.0 lb P. Sq. Ft.	Class A Load/g	Class B Load/g	Class C Load/g	E 16,000- 000	E 12,000- 000
500,000	0.819	0.3924	23,540	13,340	1.525	2.345	2.989	1.024	1.213	2.126	1.837	2.640	3.668	6,378,400	4,708,800
450,000	0.770	0.3535	21,210	12,020	1.373	2.143	2.791	0.963	1.150	2.061	1.677	2.464	3.431	5,636,800	4,242,000
400,000	0.728	0.3141	18,860	10,680	1.220	1.982	2.599	0.910	1.113	1.942	1.532	2.294	3.305	5,025,600	3,789,200
350,000	0.679	0.2750	16,590	9,350	1.068	1.801	2.401	0.849	1.119	1.997	1.364	2.120	3.123	4,409,000	3,300,000
300,000	0.630	0.2369	14,160	8,025	0.915	1.618	2.203	0.783	1.067	1.933	1.208	1.949	2.944	3,776,000	2,832,000
250,000	0.590	0.1965	11,790	6,680	0.762	1.440	2.012	0.738	1.060	1.916	1.061	1.788	2.778	3,144,000	2,358,000
0000	0.530	0.1662	9,370	5,650	0.645	1.286	1.831	0.663	1.020	1.831	0.925	1.641	2.511	2,659,200	1,984,400
000	0.470	0.1318	7,910	4,480	0.512	1.116	1.651	0.583	0.960	1.806	0.780	1.485	2.446	2,108,800	1,581,600
00	0.420	0.1045	6,270	3,555	0.406	0.978	1.498	0.525	0.947	1.760	0.664	1.361	2.311	1,672,000	1,254,000
0	0.375	0.0829	4,970	2,820	0.322	0.866	1.372	0.469	0.917	1.719	0.569	1.261	2.199	1,328,400	994,800
1	0.330	0.0657	3,940	2,235	0.255	0.771	1.263	0.413	0.837	1.678	0.485	1.175	2.100	1,051,200	788,400
2	0.291	0.0521	3,120	1,770	0.203	0.695	1.176	0.364	0.861	1.642	0.417	1.107	2.019	833,600	625,200
3	0.261	0.0413	2,480	1,405	0.160	0.633	1.106	0.326	0.841	1.614	0.363	1.053	1.955	660,800	495,600
4	0.231	0.0323	1,970	1,115	0.127	0.582	1.042	0.289	0.821	1.587	0.316	1.006	1.899	524,800	393,600
5	0.206	0.0260	1,560	885	0.101	0.540	0.992	0.258	0.804	1.564	0.277	0.970	1.852	416,000	312,000
6	0.184	0.0206	1,235	700	0.080	0.505	0.951	0.230	0.789	1.543	0.243	0.936	1.813	329,600	247,200

TABLE 83  
COPPER WIRE—SOLID—BARE

Gauge B. & S. Inches	Diarn. Area Sq. In.	HARD DRAWN		SOFT DRAWN	LOAD PER LIN. FOOT VERTICAL			LOAD PER LIN. FOOT HORIZONTAL				MAX. LOAD PER LIN. FOOT PLANE OF RESULTANT			EA	
		Ulti- mate Tension Lbs.	Ult Tens'n Lbs.		Dead	Dead + 1/2 Ice	Dead + 3/4 Ice	150 lb P. Sq. Ft.	80 lb P. Sq. F. Sq. Ft.	11.0 lb P. Sq. F. Sq. Ft.	Class A Load'g	Class B Load'g	Class C Load'g	E 16,000,- 000	E 12,000,- 000	
0000	0.460	0.1662	8,310	5,650	0.641	1.238	1.770	0.575	0.973	1.757	0.861	1.576	2.522	2,659,260	1,994,400	
000	0.410	0.1318	6,590	4,480	0.569	1.074	1.561	0.512	0.940	1.750	0.732	1.427	2.365	2,106,800	1,561,600	
00	0.365	0.1045	5,220	3,555	0.403	0.940	1.443	0.456	0.810	1.709	0.608	1.309	2.237	1,672,000	1,254,000	
0	0.305	0.0829	4,560	2,820	0.320	0.833	1.323	0.406	0.833	1.673	0.517	1.214	2.133	1,326,400	994,800	
1	0.239	0.0657	3,740	2,235	0.253	0.744	1.222	0.362	0.866	1.640	0.442	1.137	2.046	1,051,200	788,400	
2	0.218	0.0521	3,120	1,770	0.202	0.673	1.143	0.322	0.838	1.611	0.390	1.075	1.975	833,600	625,200	
3	0.229	0.0413	2,480	1,405	0.159	0.613	1.072	0.287	0.820	1.585	0.328	1.024	1.914	660,800	495,600	
4	0.204	0.0328	1,960	1,115	0.126	0.564	1.016	0.255	0.803	1.567	0.284	0.981	1.863	524,800	393,600	
5	0.123	0.0260	1,560	885	0.109	0.524	0.969	0.227	0.788	1.542	0.245	0.946	1.821	416,000	312,000	
6	0.102	0.0206	1,240	700	0.079	0.481	0.930	0.203	0.775	1.524	0.218	0.917	1.789	329,600	247,200	

TABLE 84  
COPPER WIRE—SOLID, TRIPLE BRAID WEATHER-PROOFING

Gauge B. & S.	Ext. Diam. Inches	Area Sq. In.	HARD DRAWN		LOAD PER LIN. FOOT VERTICAL		LOAD PER LIN. FOOT HORIZONTAL			MAX. LOAD PER LIN. FOOT PLANE OF RESURGENT			EA		
			Ulti- Tension Lbs.	Ult. Tension Lbs.	Dead $\frac{1}{2}$ " Ice	Dead $\frac{1}{4}$ " Ice	15.0 lb P. Sq. Ft.	8.0 lb P. Sq. Ft. $\frac{1}{2}$ " Ice	11.0 lb P. Sq. Ft. $\frac{1}{4}$ " Ice	Class A Load/g	Class B Load/g	Class C Load/g	E 16,000- 000	E 12,000- 000	
0000	0.640	0.1662	8,310	5,650	0.767	1.476	2.064	0.890	1.093	1.961	1.108	1.837	2.847	2,659,200	1,994,400
000	0.593	0.1318	6,590	4,430	0.629	1.309	1.883	0.741	1.063	1.918	0.972	1.696	2.637	2,108,800	1,681,600
00	0.515	0.1045	5,230	3,555	0.502	1.133	1.642	0.644	1.010	1.847	0.818	1.518	2.498	1,672,000	1,254,000
0	0.500	0.0829	4,560	2,820	0.407	1.029	1.575	0.625	1.000	1.833	0.766	1.434	2.415	1,326,400	994,800
1	0.453	0.0657	3,766	2,325	0.316	0.909	1.433	0.564	0.963	1.790	0.646	1.328	2.396	1,051,200	788,400
2	0.437	0.0621	3,120	1,770	0.260	0.843	1.367	0.546	0.888	1.775	0.605	1.276	2.240	833,600	625,200
3	0.406	0.0413	2,450	1,405	0.199	0.763	1.278	0.507	0.897	1.747	0.545	1.208	2.164	600,600	496,600
4	0.359	0.0328	1,960	1,115	0.164	0.698	1.199	0.449	0.906	1.704	0.478	1.143	2.083	524,800	393,600
5	0.344	0.0260	1,560	885	0.125	0.640	1.146	0.430	0.896	1.690	0.451	1.113	2.042	416,000	312,000
6	0.326	0.0206	1,240	700	0.112	0.637	1.118	0.410	0.885	1.675	0.435	1.084	2.014	329,600	247,200

TABLE 85  
ALUMINUM WIRE—STRAINED—BARE

Gauge B. & S.	Ext. Diam. Inches	Area Sq. In.	HARD DRAWN Tension Lbs	LOAD PER LIN. FOOT VERTICAL			LOAD PER LIN. FOOT HORIZONTAL			MAX. LOAD PER LIN. FOOT PLANE OF RESULTANT			EA
				Dead	Dead + $\frac{1}{2}$ " Ice	Dead + $\frac{3}{4}$ " Ice	15.0 lb P. Sq. Ft.	8.0 lb P. Sq. Ft. $\frac{1}{2}$ " Ice	11.0 lb P. Sq. Ft. $\frac{3}{4}$ " Ice	Class A Load/g	Class B Load/g	Class C Load/g	
500,000	0.814	0.3924	9,025	0.460	1.280	1.919	1.018	1.209	2.121	1.117	1.762	2.860	9,000,000
450,000	0.772	0.3535	8,130	0.414	1.206	1.834	0.965	1.181	2.002	1.050	1.637	2.775	8,181,500
400,000	0.725	0.3141	7,225	0.368	1.130	1.744	0.906	1.150	2.040	0.977	1.612	2.684	7,225,000
350,000	0.679	0.2750	6,325	0.322	1.055	1.655	0.849	1.119	1.977	0.906	1.538	2.594	6,325,000
300,000	0.621	0.2360	5,430	0.276	0.973	1.555	0.778	1.081	1.944	0.823	1.454	2.489	5,430,000
250,000	0.567	0.1965	4,520	0.230	0.894	1.459	0.709	1.045	1.895	0.745	1.375	2.392	4,520,000
0000	0.522	0.1662	3,620	0.195	0.821	1.362	0.652	1.015	1.853	0.681	1.312	2.312	3,620,000
000	0.464	0.1312	2,760	0.155	0.755	1.268	0.580	0.976	1.800	0.600	1.234	2.213	2,760,000
00	0.416	0.1045	2,510	0.122	0.691	1.208	0.518	0.943	1.754	0.532	1.168	2.130	2,510,000
0	0.368	0.0679	1,990	0.097	0.637	1.140	0.460	0.912	1.712	0.470	1.112	2.057	1,990,000
1	0.328	0.0657	1,575	0.077	0.592	1.062	0.410	0.845	1.676	0.417	1.065	1.965	1,575,000
2	0.291	0.0621	1,250	0.061	0.533	1.002	0.364	0.861	1.642	0.368	1.023	1.939	1,250,000
3	0.261	0.0415	990	0.049	0.522	0.962	0.326	0.841	1.614	0.329	0.990	1.894	990,000
4	0.031	0.0328	790	0.039	0.494	0.964	0.289	0.821	1.587	0.292	0.958	1.846	790,000

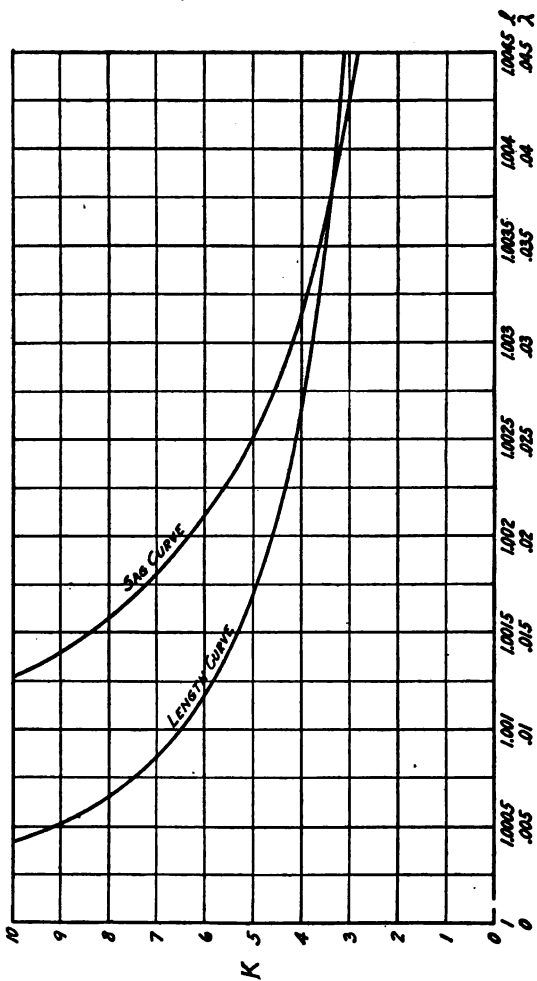

FIG. 318.—Relation between length and sag per foot of span, and total stress in conductor per pound of conductor one foot long.

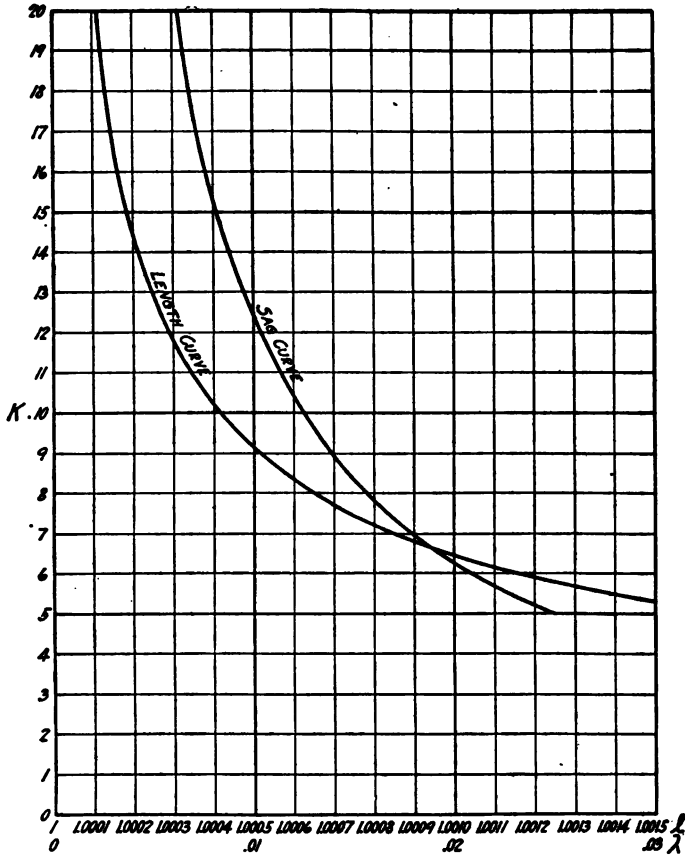

FIG. 319.—Relation between, length and sag per foot of span, and total stress in conductor per pound of conductor one foot long.



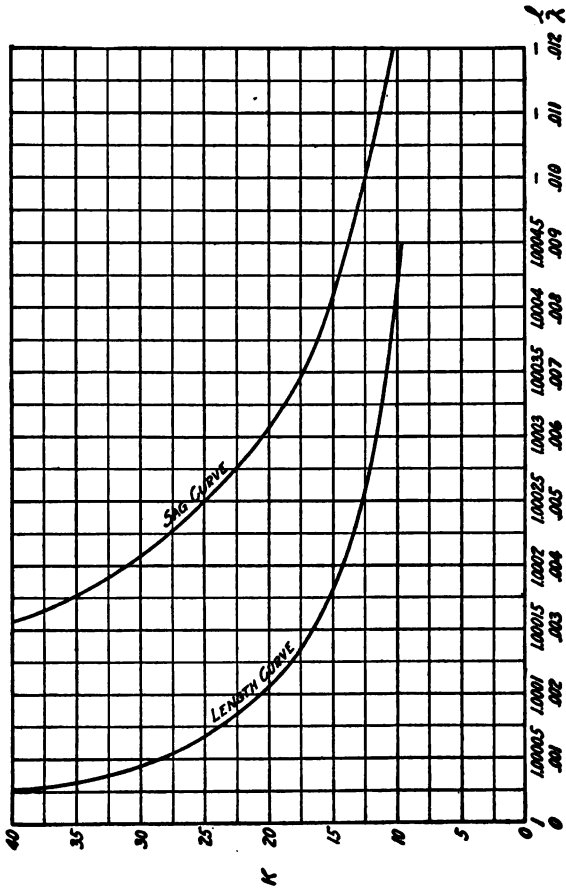

Fig. 320.—Relation between length and sag per foot of span, and total stress in conductor per pound of conductor one foot long.

**TABLE 86**  
**DATA FOR PLOTTING LENGTH AND SAG CURVES**

$l$	$\lambda$	$k$
1.0000042	0.00125	100.0013
1.0000051	0.00132	90.9105
1.0000061	0.00150	83.3348
1.0000071	0.00162	76.9247
1.0000082	0.00175	71.4303
1.0000094	0.00188	66.6685
1.0000107	0.00200	62.5020
1.0000118	0.00212	58.8257
1.0000136	0.00225	55.5578
1.0000151	0.00238	52.6339
1.0000167	0.00250	50.0025
1.0000261	0.00313	40.0031
1.0000372	0.00375	33.3371
1.0000511	0.00438	28.5758
1.0000667	0.00500	25.0050
1.000104	0.00625	20.0063
1.000150	0.00750	16.6742
1.000266	0.01000	13.5100
1.000417	0.01250	10.9125
1.000598	0.01500	8.3483
1.000817	0.01751	7.1604
1.001066	0.02001	6.2700
1.001351	0.02252	5.5781
1.001668	0.02502	5.0250
1.002017	0.02753	4.5730
1.002402	0.03004	4.1967
1.003754	0.03757	3.3709
1.006680	0.05017	2.5502
1.010444	0.06283	2.0628
1.015068	0.07556	1.7422
1.020542	0.08840	1.5170
1.026881	0.10134	1.3513
1.034093	0.11441	1.2255
1.042191	0.12763	1.1276
1.051185	0.14100	1.0501
1.061089	0.15455	0.9879
1.083691	0.18226	0.8965

Draw  $\lambda$  a parallel to  $oy$  and intersecting sag curve at  $b$ ; draw  $Kc$  through  $b$  parallel to  $ox$  and intersecting length curve at  $d$ . Drop a perpendicular  $dl$ . (Fig. 317.)

$$K = 5.6.$$

$$l = 1.00134$$

$$s = \frac{K W D}{a} = \frac{5.6 \times 0.122 \times 200}{0.1045} = 1308 \text{ lbs. per square inch.}$$

$$l_0 = 1 - \frac{s}{E} = 1.00134 - \frac{1308}{9,000,000} = 1.0011947.$$

Lay off  $l_0$  from 0.

$$l' = 1 + \frac{s}{E} \left( \frac{W_1}{W} - 1 \right) = 1.00134 + \frac{1308}{9,000,000} \times (9.56 - 1)$$

$$l' = 1.002586.$$

Lay off  $l'$  from 0 and draw  $l'e$  parallel to  $oy$ , intersecting  $Kc$  at  $f$ . Draw  $l_0g$  through  $f$ .

$$l'_0 = l_0 - \alpha(t - t_1) = 1.0011947 - 0.0000128(70 - 10) =$$

$$l'_0 = 1.0004267.$$

Lay off  $l'_0$  from 0 and draw  $l'_0h$  parallel to  $l_0g$  intersecting the length curve at  $i$ ; draw a line  $K_1j$  parallel to  $ox$  through  $i$  and intersecting the sag curve at  $m$ , drop a perpendicular line  $\lambda_1m$  from  $m$ .

$$\lambda_1 = 0.02515.$$

$$K_1 = 5.025.$$

Then

$$T_1 = K_1 W_1 D = 5.025 \times 1.168 \times 200 = 1176 \text{ pounds.}$$

$$s_1 = \frac{K_1 W_1 D}{a} = \frac{1176}{0.1045} = 11,230 \text{ pounds per square inch.}$$

$$d_1 = \lambda_1 D = 0.02515 \times 200 = 5.03 \text{ feet.}$$

$$d_1 = 5.03 \times 12 = 60.36 \text{ inches.}$$

### CROSS-ARMS

15. General. The ordinary stresses on cross-arms may be divided into two classes.

1. The stress produced by the bending moment caused by the weight of the wires. (Vertical.) (Art. 16.)

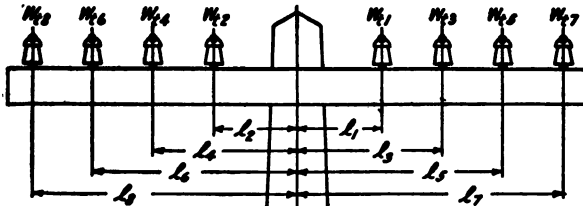

FIG. 321.

2. The stress produced by the bending moment caused by an unbalanced tension of the wires. (Horizontal.) (Art. 17.)  
The solution of problems to determine the following stresses has not been included for the reasons outlined below, although in some cases they may be of importance.

1. Shear and compression, as calculations indicate that such stresses in cross-arms are negligible.
2. Torsion, since the bending of the cross-arm renders calculated stress values very unreliable.
3. Torsion on poles and cross-arms due to broken wires as the relative flexibility of the pole will introduce an error of approximately 50% in the calculated results.

16. **Bending Moment Due to the Weight of the Conductor.** (Fig. 321.)

Let

$D_1$  &  $D_2$  = length of adjacent spans in ft.

$T_u$  = the unbalanced tension in the conductor in lbs.

$l_1, l_2, l_3$  etc. = the lever arm or distance from the center of the pole to the center of the pins in inches.

$l$  = the distance between pins in inches (assuming the distance from the center of the pole to the pole pin equals  $l$ ).

$W_{t1}, W_{t2}, W_{t3}$ , etc. = the total weight of the respective conductors supported by the pins.

$n$  = the number of pins in the cross-arm.

$M$  = the bending moment in pound-inches.

Then

$$M = (W_{t1} l_1 + W_{t2} l_2 + W_{t3} l_3 + \dots + W_{t_{n-1}} l_{n-1})$$

or

$$M = (W_{t2} l_2 + W_{t4} l_4 + W_{t6} l_6 + \dots + W_{tn} l_n).$$

The above formulæ are simplified when all the wires have the same weight, then—

$$M = W_{t1} l \left( 1 + 2 + 3 + 4 + \dots + \frac{n}{2} \right)$$

**Problem:** Find the fiber stress in pounds per square inch in a six pin, 8 ft,  $3\frac{1}{2} \times 4\frac{1}{2}$  standard cross-arm, each pin supporting a No. 00 stranded bare copper wire, with the additional load of  $\frac{1}{2}$ " covering of ice; assuming 200 ft. spans.

**Solution:**

From Table 82.

$$W_t = 0.978.$$

$$\frac{n}{2} = 3$$

$$W_{ti} = \frac{(D_1 + D_2)W_t}{2}$$

$$W_{ti} = \frac{400 \times 0.978}{2} = 195.6 \text{ lbs.}$$

$$l = 14\frac{1}{2}''$$

$$M = 195.6 \times 14.5 (1+2+3).$$

$$M = 195.6 \times 14.5 \times 6 = 17,020 \text{ lbs.-inches.}$$

$$s = \text{Fiber stress.}$$

$$s = \frac{6M}{b d^2} \quad \text{Table 78.}$$

$$b = \text{Dimensions of cross-arm in inches at } 90^\circ \text{ to force.}$$

$$d = \text{dimensions of cross-arm in inches parallel to force.}$$

$$s = \frac{6 \times 17,020}{3.5 \times (4.5)^2} = 1,443 \text{ lbs. per square inch.}$$

The weight of the insulators and ice on the cross-arm, the reduction in cross-section due to the bolt holes, and the supporting effect of the braces have not been considered as they effect the result by less than 5% and are generally covered by the factors of safety used.

**17. Bending Moment Due to the Unbalanced Tension in Conductors exemplified by dead ending the line.**

**Problem:**

Find the fiber stress in pounds per square inch in each of two 4-pin 5 ft. 7 inches,  $3\frac{1}{2}'' \times 4\frac{1}{2}''$  standard cross-arms and supporting through pin type insulators to each of which is attached a No. 00 hard-drawn stranded bare copper wire.

**Solution:**

If a through pin type insulator is used on two arms and considering the wire stress  $T_u = 1,975$  lbs. (From Art. 14.)

Then

$$M = 1,975 \times 14.5 (1+2) = 86,000 \text{ lbs. inches for two arms.}$$

$$M = 43,000 \text{ lbs. inches for one arm.}$$

$$s = \frac{6 \times 43,000}{4.5 \times (3.5)^2} = 4,675 \text{ lbs. per square inch.}$$

**Double arms**, as generally used, to which wires are connected to insulators in tandem, complicate the problem in that a form of cantilever truss is thereby produced.

In the solution of such problems, the load is divided by two and the fiber stress for a single arm is calculated. This solution assumes

that the load is equally divided between the two cross-arms and neglects the truss effect.

### 18. POLE STRESSES

#### Forces Producing Pole Stresses.

Wind pressure on the pole. (Art. 19.)

Wind pressure on the conductors. (Art. 19.)

Unbalanced wire tension.

a—Dead ends. (Art. 20.)

b—Bends in a line. (Art. 21.)

### 19. Wind Pressure on Pole and Conductors.

#### Symbols:

$F$  = the wind pressure in pounds per sq. ft. of projected area of pole or wires (Art. 2).

$F_0$  = the wind pressure in lbs. per ft. length of wire. (Art. 10.)

$s$  = the fiber stress of pole in lbs. per square inch.

$H$  = the height of pole in feet above ground.

$d_1$  = the diameter of pole at ground in inches.

$d_2$  = the diameter of pole at top in inches.

$d_3$  = the diameter of pole where effect of load is applied.

$D_1$  &  $D_2$  = the adjacent spans in feet.

$n_1$  = the number of wires at dist.  $L_1$  from ground.

$n_2$  = the number of wires at dist.  $L_2$  from ground.

$L$  = the effective lever arm in feet.

$P_p$  = the total wind pressure on pole.

$P_{c1}$  = the total wind pressure on wires  $L_1$  feet from ground.

$P_{c2}$  = the total wind pressure on wires  $L_2$  feet from ground.

$M_p$  = the bending moment of pole.

$M_{c1}$  = the bending moment of wire at dist.  $L_1$  from ground.

$M_{c2}$  = the bending moment of wire at dist.  $L_2$  from ground.

$M_t$  = the total bending moment.

Then

$$M_p = \frac{FH^2 (d_1 + 2d_2)}{72} \text{ lb.-ft.}$$

$$M_{c1} = \frac{n_1 F_0 L_1 (D_1 + D_2)}{2} \text{ lb.-ft.}$$

$$M_{c2} = \frac{n_2 F_0 L_2 (D_1 + D_2)}{2} \text{ lb.-ft.}$$

$$P_p = \frac{(d_1 + d_2) HF}{24} \text{ lb.}$$

$$P_{c1} = F_0 n_1 \frac{(D_1 + D_2)}{2} \text{ lb.}$$

$$P_{c2} = F_0 n_2 \frac{(D_1 + D_2)}{2} \text{ lb.}$$

## Sec. 8 MECHANICAL CALCULATIONS

$$M_t = M_p + M_{c1} + M_{c2} \text{ lb.-ft.}$$

$$L = \frac{M_t}{P_p + P_{c1} + P_{c2}} \text{ ft.}$$

$$d_2 = d_1 - (d_1 - d_2) \frac{L}{H} \text{ inches.}$$

$$s = \frac{M_t}{K} \frac{\text{lbs.}}{\text{in}^2}.$$

$$K = \frac{(d_1 - d_2) d_2^2}{18.1152}$$

When  $d_1 > 1.5 d_2$  \*\*

$$K = \frac{d_1^3}{122.208}$$

When  $d_1 < 1.5 d_2$

For values of  $K$  for variations in  $d_1$  and  $d_2$  see Fig. 322.\*

The curves in Fig. 323† were obtained as follows:

Symbols:

$d_0$  = rot diameter in inches.

$d_1$  = diameter at ground line in inches.

$d_2$  = diameter where load is applied in inches.

$M_o$  = bending moment on rotted pole in lb.-ft.

$M$  = bending moment on new pole in lb.-ft.

$s$  = fibre stress per square inch at bending moment  $M$ .

$s_o$  = fibre stress per square inch at bending moment  $M_o$ .

$$\eta = \frac{M_o}{M}$$

$$M = \frac{(d_1 - d_2) d_2^2 s}{18.1152}$$

$$M_o = \frac{d_o^3 s_o}{122.208}$$

$$\eta = \frac{M_o}{M} = \frac{d_o^3 s_o}{122.208 \frac{(d_1 - d_2) d_2^2 s}{18.1152}}$$

$$\eta = \frac{18.1152 s_o}{122.208 s} \times \left(\frac{d_o}{d_1}\right)^3 \times \frac{1}{\left(\frac{d_2}{d_1}\right)^2 - \left(\frac{d_2}{d_1}\right)^3}$$

\*\* The weakest section of a wood pole is where the diameter is equal to 1.5 times the diameter of the point of application of the resultant load.

\* For sawed square timber  $K$  as found from Fig. 322 should be increased 70%.]

† Curves are equally correct for sawed square timber or round timber.

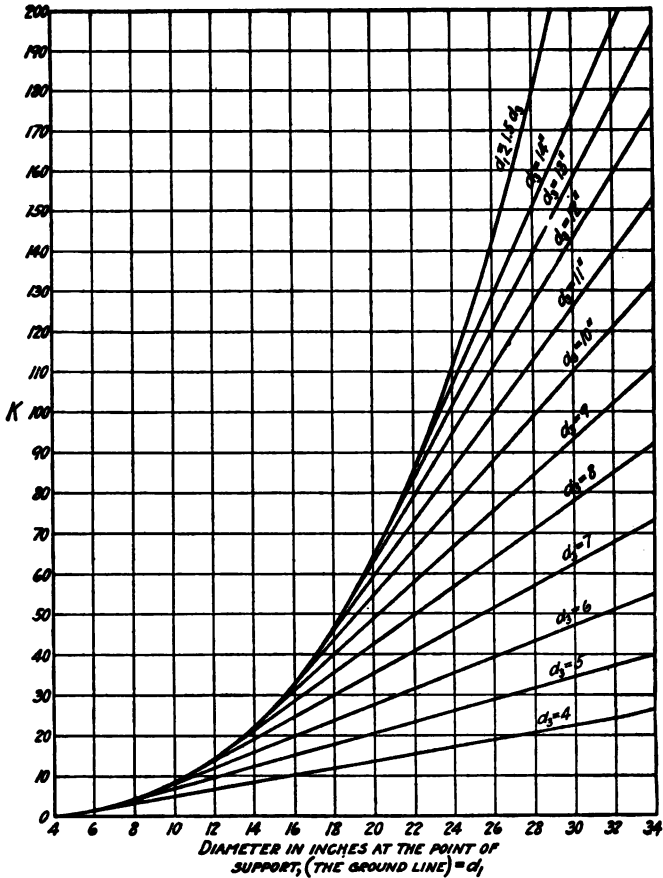

FIG. 322. Fibre stress in  $\frac{lb}{in^2}$  per lb-ft. of bending moment,  $-\frac{1}{2}$ .



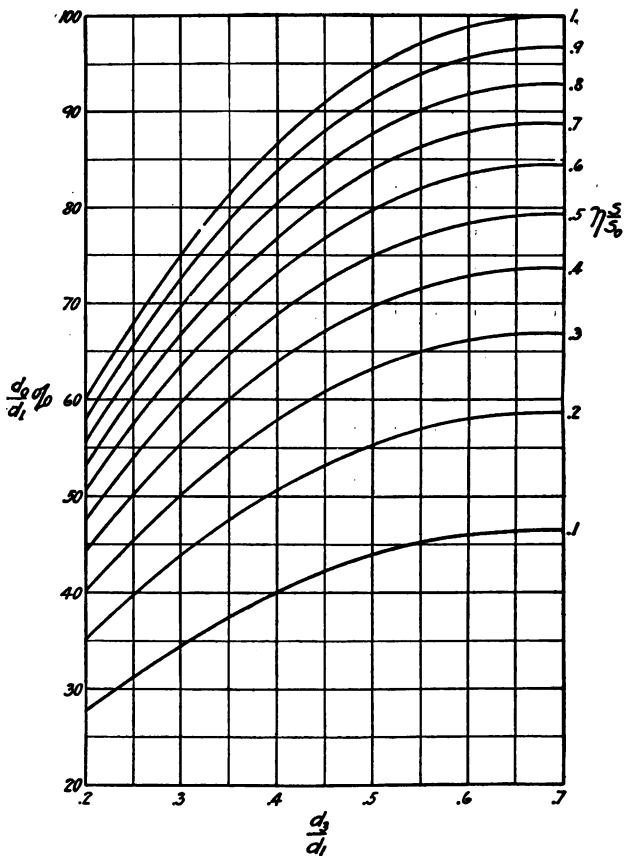

Fig. 323.—Relation between rotted diameter of pole, bending moment and fibre stress.

$$\frac{d_o}{d_i} = 1.889 \sqrt[3]{\left[\left(\frac{d_s}{d_i}\right)^3 - \left(\frac{d_s}{d_i}\right)^2\right] \eta \frac{s}{s_o}}$$

$d_o$  as a percent of  $d_i$

$$d_o = 188.9 \sqrt[3]{\left[\left(\frac{d_s}{d_i}\right)^3 - \left(\frac{d_s}{d_i}\right)^2\right] \eta \frac{s}{s_o}}$$

The curves in Fig. 323 illustrate the per cent of the original diameter to which a given pole may rot before the strength is less than that of a sound pole; also the per cent of the original diameter at which the pole will break.

If the bending moment remains constant,  $\eta = 1$ ; the percentage rot diameter *i. e.*, the ratio of the diameter of the rotted pole to the original ground line diameter will vary in accordance with curve (1) depending upon the ratio  $\frac{d_s}{d_i}$ . If the stress is greater the value of the rotted diameter will be determined by the curve indicated by the value of  $\frac{s}{s_o}$ ,  $\eta$  remaining equal to one.

If the load on the pole is increased  $\eta$  will be greater than one and the rotted diameter of the pole is determined by the curve indicated by the value of  $\eta \frac{s}{s_o}$ . These curves may be interpolated with accuracy.

#### Problem:

Find the top and ground line diameter necessary for a 40 ft. chestnut pole, set 6 ft. in the ground to which are attached 3 No. 00 bare stranded copper wires, one at the top and two 3 ft. from the top; the wires coated with  $\frac{1}{2}$ " of ice, and a wind pressure of 8 lbs. per square foot on the pole and the ice covered wires. The adjacent spans are 150 and 200 feet long.

#### Solution:

Solve first for wire and ice load alone. Table 82 for No. 00 stranded copper,  $\frac{1}{2}$  ice and 8 lbs. wind  $F_o = 0.947$ .

Wire on top of pole.

$$M_{c1} = 1 \times 0.947 \times 34 \frac{(150+200)}{2} = 5,650 \text{ lbs.-ft.}$$

Wires on cross arms.

$$M_{c2} = 2 \times 0.947 \times 31 \frac{(150+200)}{2} = 10,290 \text{ lbs.-ft.}$$

$$M_{c1} + M_{c2} = 15,940 \text{ lbs.-ft.}$$

Since the top and ground line diameter of the pole are not known, it is necessary to assume a value for the maximum allowable fibre stress which in this solution is made 1200 lbs. per square inch.

Then

$$K = \frac{M_{c1} + M_{c2}}{s} = \frac{15,940}{1200} = 13.3$$

From Fig. 322 for  $K = 13.3$ . A 40 ft. class "B" pole, Sec. 2, Art. 16, may be used, since it has a ground line and top diameter equal to about 13" and 7" respectively.

Since, as mentioned in the foregoing, the wind pressure has been considered for the wires only, it is necessary in order to find the maximum fibre stress in the pole to recalculate the problem for the pole selected by the above method, including in the calculation the effective wind pressure on the pole.

$$d_2 = \frac{22''}{\pi} = 7$$

$$d_1 = \frac{43}{\pi} = 13.7$$

$$M_p = \frac{8 \times (34)^2 \times (13.7 + 2 \times 7)}{72} = 3,560 \text{ lb.-ft.}$$

$$M_{c1} = 5,650 \text{ lb.-ft.}$$

$$M_{c2} = 10,290 \text{ lbs.-ft.}$$

$$M_t = 19,500 \text{ lb.-ft.}$$

$$P_p = \frac{(13.7 + 7)}{24} \times 34 \times 8 = 234.5 \text{ lbs.}$$

$$P_{c1} = 1 \times 0.947 \times \frac{(150 + 200)}{2} = 166 \text{ lbs.}$$

$$P_{c2} = 2 \times 0.947 \times \frac{(150 + 200)}{2} = 332 \text{ lbs.}$$

$$L = \frac{19,500}{234.5 + 166 + 332} = \frac{19,500}{732.5} = 26.6 \text{ ft.}$$

$$d_3 = 13.7 - (13.7 - 7) \frac{26.6}{34} = 8.46$$

For  $d_3 = 8.46$

$$d_1 = 13.7$$

Find  $K = 21$  (Fig. 322).

$$s = \frac{M_t}{K} = \frac{19,500}{21} = 928 \text{ lbs. per square inch.}$$

Having determined for the selected pole the maximum fibre stress per square inch (928 pounds) it follows that a certain decrease in ground line diameter may take place due to rotting before the pole will fail. This value is determined as follows:

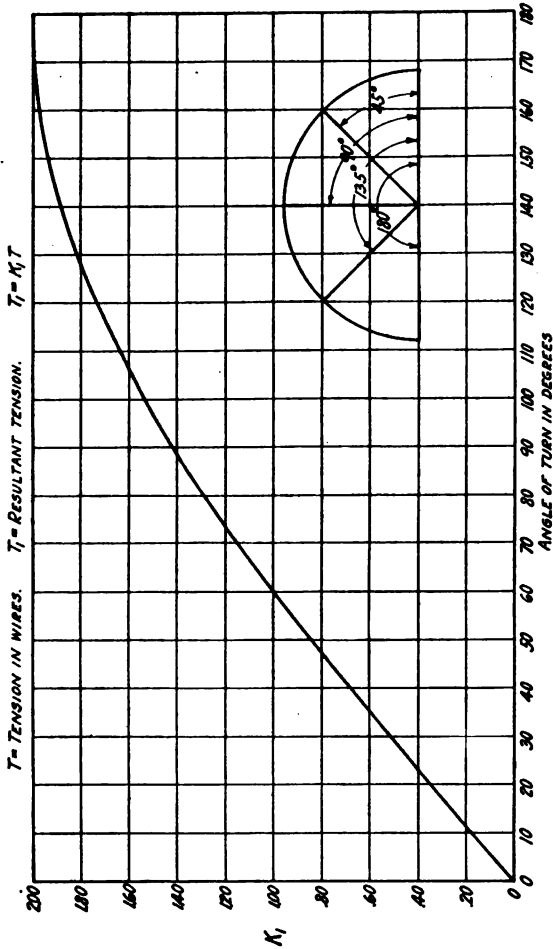

Fig. 324.—Relation between tension in wires and resultant tension of pins due to a change in the direction of the line.

## Sec. 8 MECHANICAL CALCULATIONS

Assume the bending moment on the pole to be the same when rotted as when new;

$$\text{Then } \eta = \frac{M_o}{M} = 1$$

The modulus of rupture of chestnut is 5100 lbs. per square inch, therefore, to break the pole  $\frac{s}{s_o}$  must equal  $\frac{928}{5100} = 0.182$ .

$$\frac{d_3}{d_1} = \frac{8.46}{13.7} = 0.616$$

Interpolation of the curves in Fig. 323 between  $\eta \frac{s}{s_o} = 0.1$  and 0.2 shows that the diameter may be rotted to 56% of the original ground line diameter.

$$\text{Rotted diameter} = \frac{56 \times 13.7}{100} = 7.66 \text{ inches.}$$

### 20. Dead End Loading.

$$M_{c1} = L_1 T_{u1} n_1$$

$$M_{c2} = L_2 T_{u2} n_2$$

#### Problem:

Find the stress in a 40 ft. chestnut pole, set six feet in the ground, when subjected to the bending moment due to dead ending three No. 00 bare stranded copper wires, one at the top and two, three feet from the top. Assume a 200 ft. span.

#### Solution:

$$T_{u1} = T_{u2} = 1,975 \text{ lbs. (From Art. 13, Prob. 1.)}$$

$$n_1 = 1$$

$$n_2 = 2$$

$$M_{c1} = 34 \times 1,975 \times 1 = 67,150 \text{ lb.-ft.}$$

$$M_{c2} = 31 \times 1,975 \times 2 = 122,300 \text{ lb.-ft.}$$

$$M_t = 67,150 + 122,300 = 189,450.$$

$$K = \frac{M_t}{s} = \frac{189,450}{1,200} = 157.9.$$

No standard 40-ft. pole will meet this condition. (See Fig. 322.)

$$K = \frac{M_t}{s} = \frac{189,450}{5,100} = 37.2.$$

This will break a standard 40-ft. pole. Assuming in both cases that the pole does not bend and relieve the wire stress. Such a pole may be used, if guyed as shown in Art. 22.

**21. Bends in Line or change in line direction.**

Assume a 15° angular change in the line.

From Fig. 324  $T_{u1}$  equals 26% of the tension in wires.

$$T_{u1} = T_{u2} = .26 \times 1,975 = 514 \text{ lbs. (Art. 13, Prob. 1.)}$$

$$M_{c1} = 34 \times 514 \times 1 = 17,480 \text{ lbs.-ft.}$$

$$M_{c2} = 31 \times 514 \times 2 = 31,900 \text{ lbs.-ft.}$$

$$M_t = 49,380 \text{ lbs.-ft.}$$

A 15° bend is similar in effect to dead ending, but not to so great an extent.

For a 90° bend, however, from Fig. 324.

$$T_u = 1.41 \times 1,975 = 2,785 \text{ lbs.}$$

$$M_{c1} = 34 \times 2,785 \times 1 = 94,600 \text{ lbs.-ft.}$$

$$M_{c2} = 31 \times 2,785 \times 2 = 172,900 \text{ lbs.-ft.}$$

$$M_t = \dots\dots\dots 267,500 \text{ lbs.-ft.}$$

which is worse than dead end loading.

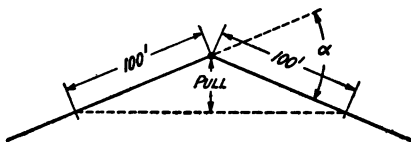

FIG. 325.

If it is desired to use pull instead of the curve in Fig. 324.

P = pull (Fig. 325).

$T_u$  = resulting tension on wire supports.

T = tension in wires.

Then

$$T_u = \frac{2 P T}{100}$$

**22. GUYING.**

$M_t$  = total moment on pole.

$L_g$  = height of point of guy attachment from ground.

$L$  = distance of guy anchor from base of pole.

$T_g$  = tension in guy wire.

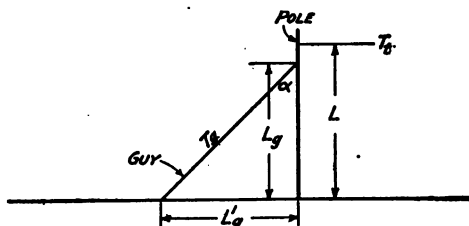

FIG. 326.

$$M_t = T_t L$$

$$T_g = \frac{M_t}{L_g \sin \alpha} \quad (1) \quad (\text{Fig. 326.})$$

$$\sin \alpha = \frac{1}{\sqrt{1 + \left(\frac{L'_g}{L_g}\right)^2}}$$

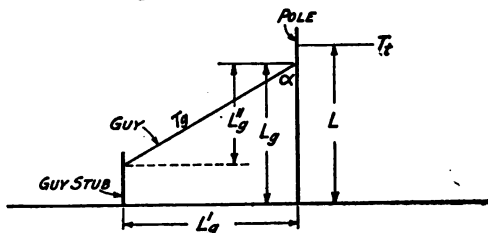

FIG. 327.

$$T_g = \frac{M_t}{L_g \sin \alpha}$$

$$\sin \alpha = \frac{1}{\sqrt{1 + \left(\frac{L'_g}{L_g}\right)^2}} \quad (\text{Fig. 327.})$$

**Problem:**

Assuming the bending moment as determined in Art 21 for a  $90^\circ$  bend.

$M_t = 267,500$  lbs.-ft.

Guy attached three feet from top of pole.

$L_g = 31$  feet; foot of guy 30 ft. from base of pole (Fig. 326).

$$\sin \alpha = \frac{1}{\sqrt{1 + \left(\frac{31}{30}\right)^2}} = 0.696$$

$$T_g = \frac{267,500}{31 \times 0.696} = 12,400 \text{ lbs.}$$

If a factor of safety of three is used the breaking strength of the guy must be  $12,400 \times 3 = 37,200$  lbs. This necessitates the use of two Siemens Martin  $\frac{5}{8}$ " galvanized strands having an ultimate strength of 19,000 lbs. each.

$$19,000 \times 2 = 38,000 \text{ lbs.}$$

**23. CONCRETE AND STEEL STRUCTURES.** It will be noted from the above that the solutions have been confined to wood poles and cross-arms for the reason that the design of steel and concrete structures introduce engineering problems which cover such a number of variables that formulæ for their solution would require a treatise on structural design.

These problems are essentially structural engineering problems and their solution should be made by men familiar with such work.

#### BIBLIOGRAPHY.

N. E. L. A. Overhead Line Committee Report, 1911.

U. S. Weather Bureau.

Transactions of International Electrical Congress, 1904.

A. I. E. E., June, 1911, Mr. P. H. Thomas.

Franklin & Esty Electrical Engineering.

Mechanics of Materials, Merriman.

Overhead Electric Power Transmission, Still.



1

2

3

4

5

6

7

8

9

10

11

12

**SECTION 9**  
**PRESERVATIVE TREATMENT OF POLES**  
**AND CROSS-ARMS**

---

**PART I**  
**GENERAL DATA**

---

**PART II**  
**RECOMMENDED PRACTICE AND SPECIFICATIONS**

---

**PART III**  
**APPENDICES**

1

2

3

4

5

6

7

8

9

10

11

12

13

14

15

16

17

18

19

20

21

22

23

Vertical line of text on the right edge

Vertical line of text on the left edge

**SECTION 9**  
**PRESERVATIVE TREATMENT OF POLES AND**  
**CROSS-ARMS**

**PART I—GENERAL DATA**

**TABLE OF CONTENTS**

	ARTICLE
<b>Introductory</b> .....	1
<b>Seasoning</b>	
General .....	2
Manner of Storing Poles and Cross-arms .....	3
Spacing .....	4
Roofing .....	5
Summary on Seasoning .....	6
<b>Preservatives</b>	
General .....	7
Structure of Wood .....	8
Sap Wood .....	9
Decay of Wood .....	10
<b>Preservative Agents</b> .....	11
Preservation with Oils .....	12
Coal Tar Creosote .....	13
Water Gas Tar Creosote .....	14
Petroleum Oil .....	15
Wood Creosote .....	16
Preservation with Salts .....	17
Summary .....	18
<b>Processes</b>	
General .....	19
High Artificial Pressure Processes .....	20
Full Cell Treatment:—Bethell .....	21
Burnett .....	22
Wellhouse .....	23
Rütgers .....	24
Card .....	25
Allardyce .....	26
Empty Cell Treatment:—Rüping .....	27
Lowry .....	28
Atmospheric Pressure Processes .....	29

**Sec. 9****WOOD PRESERVATION**

	<b>ARTICLE</b>
Full Cell Treatment, Steeping in Cold Preservative . . . .	30
Hot or Boiling . . . . .	31
Alternate, Hot and Cold . . . . .	32
Empty Cell Treatment—open tank . . . . .	33
Low Artificial Pressure Systems, Full or Empty Cell . . . . .	34
Miscellaneous Treatments, Brush . . . . .	35
Brush combined with open tank	36
Jacket or Butt setting . . . . .	37

**1. INTRODUCTORY.** The following chapter on preservative treatments consists of extracts from the 1910 and 1911 reports of this Association's Committee on Preservative Treatment of Wood Poles and Cross-arms. The first named report has been condensed in order to present only the sections on seasoning, preservatives, and processes. These general descriptions of preservative practises are given not only because they are historically and scientifically interesting, but also to properly introduce the more definite recommendations and specifications presented in Part II. Attention is called to this, as the conclusions regarding the nature of preservatives and methods of treatment given in Part II were intended to supersede the more general conclusions contained in Part I.

Much valuable data have necessarily been omitted, particularly the conclusions of the committee on preservative methods concerning which they were unable to procure sufficient information to justify recommendation. The reports of this committee are undoubtedly among the most valuable of the association and will be found printed in full in the 1910 and 1911 proceedings.

## SEASONING

**2. General.** Whether or not poles or cross-arms are to receive preservative treatment, there can be no doubt that it invariably pays to season them properly before putting them into service. Under ordinary conditions, the life of a well-seasoned, untreated pole should be at least 30 per cent greater than that of an untreated green pole, and the life of cross-arms is increased in about the same proportion through proper seasoning. For general purposes, air-dried timber should give the best results in regard to the strength after seasoning, decreased moisture content in the wood under average climatic influences, and the increased penetrability afforded to impregnation by preservative fluids.

Artificial drying or seasoning methods such as kiln drying, oven drying and steaming are employed for various reasons, but the usual object is to force the drying process. It would seem that where poles and cross-arms are used in limited quantities, and the preservative treatment is to be applied by the pole consumer, there would be no good reason for resorting to artificial means of drying. It is true, however, that some method of accelerated drying is imperative where the wood is to be treated, and sufficient time cannot be allowed to air-dry it thoroughly. It is astonishing at this late day to learn that in many instances poles and cross-arms are brush-treated while in a green state, whereby the moisture content of the wood is practically sealed within it, so that in a short time, when the superficial coating is worn or torn away fungi are admitted to the interior, and accelerated decay is encouraged. If poles and cross-arms cannot be sufficiently air-dried, or if any form of artificial drying is not resorted to, it is best not to attempt any such treatment before the poles and cross-arms are installed, and if so installed, sufficient time

should be allowed to season the arms before treating them. Nevertheless, local conditions are apt to govern; as, for instance, poles are often required to be kept painted under franchise or ordinance requirements.

**3. Manner of Storing Poles and Cross-arms.** In general,



FIG. 328.—Showing customary manner in which poles are laid in pole yards. Poles are only partially raised from the ground and no attempt made to separate them so as to allow air circulation.

whether poles are stored at some distributing point or are distributed along construction routes, the first care should be to keep them clear from the ground. If the bottom tier of a pile of poles is placed at a sufficient height from the ground, say not less than two feet, two necessary things will be accomplished—the wood will be farther removed from decay infection and, owing to the freer cir-

ulation of air, the seasoning process will be more thoroughly and quickly accomplished. If the poles are to remain for any length of time in one position, the tiers should be separated, and, if possible, the poles should not come in contact. (Figs. 328 and 329.)

Forest Circular No. 151 gives some valuable suggestions covering the proper piling and storage of cross-arms:

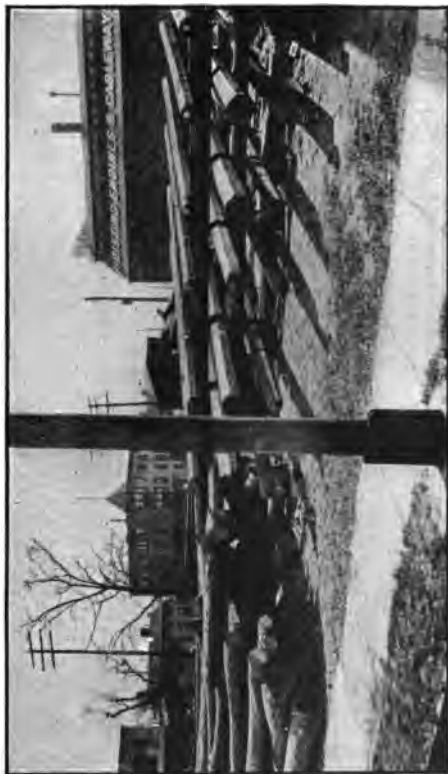

FIG. 329.—Contrasting two extremes in pole stacking. The poles to the left have been laid directly on the ground, while those to the right have been raised from the ground and are well separated.

“In addition to natural factors, another of hardly less importance is introduced in the manner of piling the timber. In general commercial practice, economy of space and handling are rightly considered of the first importance, and all other considerations are made



subservient. Present practice does not secure the best results, but if there were no means by which these could be attained, without the sacrifice of labor and of space economy, no change in the present pile forms would be recommended. However, the adoption of proper methods does not appreciably increase either labor or space.

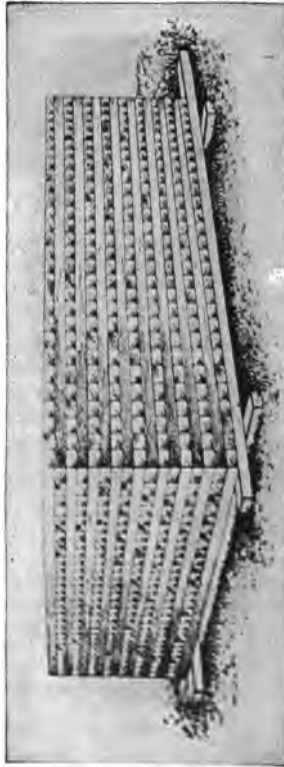

FIG. 330.—Common method of piling cross-arms in commercial practice.

4. Spacing. "In most seasoning yards, the arms are piled closely together, there being about 28 on each tier. (Fig. 330.) In some cases, however, a partial improvement is made by changing the position of either one arm or two arms at the centre and ends of the tiers, as is shown in Fig. 331. Both of these pile-forms retard the evaporation of the moisture from the wood. In the closest pile the

circulation of air is almost entirely shut off, and all evaporation must take place from the ends of the timbers. In case of heavy rain or melting snow the water trickles down over the timber, and the dampness thus promoted, together with even moderate temperatures, stimulates the growth of fungi, while the close contact of the timbers permits a rapid spread of infection.

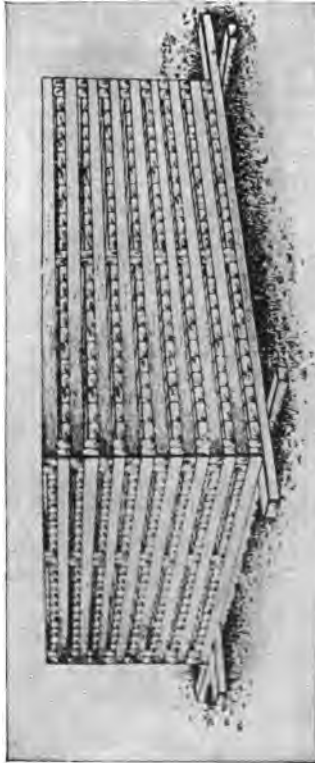

FIG. 331.—Modified form of piling cross-arms in commercial practice.

“It often happens, therefore, that where timber is so piled the growth of wood-destroying fungi has reached a serious stage before the timber itself has attained its air-dry condition. Hence it is not uncommon to hear the assertion that the sap-wood of loblolly pine will rot before it can become air-dry. Such an assertion is probably

untrue in every case, and it is certain that loblolly, or any other timber, in a form so well adapted for rapid evaporation of moisture as cross-arms, can be fully seasoned in any part of the country without a risk of deterioration during the seasoning period. By adopting the pile form shown in Fig. 331, a circulation of air is permitted along

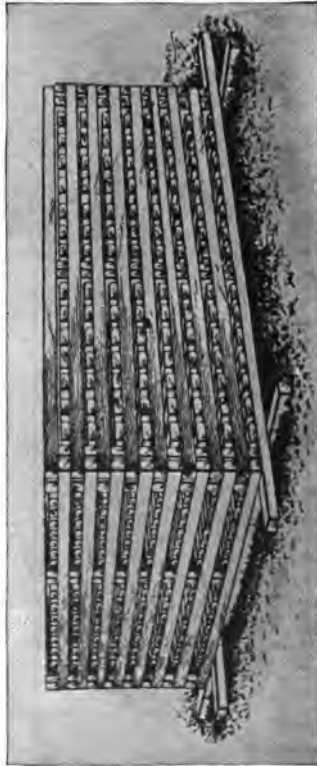

Fig. 332.—Ideal form of piling cross-arms, 20 x 20, giving free circulation of air.

the sides of the arms. The upper and lower faces are still so closely crowded together than no air current can pass between them. Obviously, the next step is to separate the arms from each other by a space of sufficient size to insure a thorough circulation of the air on all sides of the arms, and yet not so large as to consume unneces-

sary space. When these two requirements are met, the ideal form of pile is attained.

Many experiments have shown that if from 20 to 22 arms are allowed to each tier, and arranged as shown in Fig. 332, most of the desired results will be attained. This pile, called for convenience the 20-by-20 form, compared with those in general use, gives a sur-

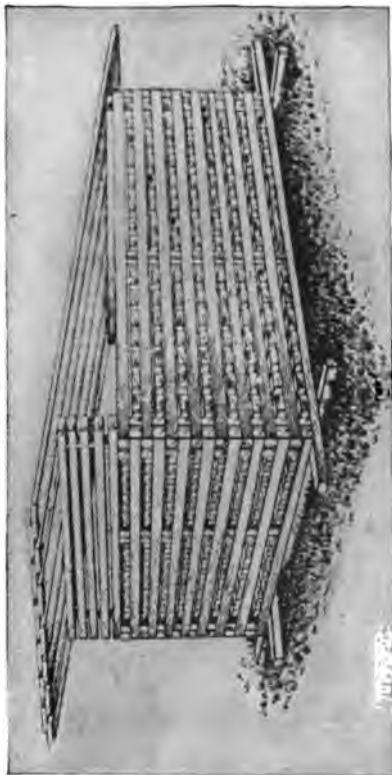

FIG. 333.—Recommended method of roofing, cross-arm piles with boards.

prising difference in the rate of seasoning. For example, sap-arms of the July allotment were piled as in Figs. 331 and 332. Those in the 20-by-20 pile dried out to a weight of 34.1 pounds per arm in a little more than six weeks, while more than sixteen weeks elapsed before a like weight was reached by the arms in the figure, or 28-by-28 pile.

## Sec. 9

## WOOD PRESERVATION

The only difference in the two piles was in the number of arms to the tier. Had the arms in the 28-by-28 pile been packed closely together, as in Fig. 330, the difference in the rate of seasoning would have been much greater.

5. Roofing. "Under climatic conditions, such as prevail in most

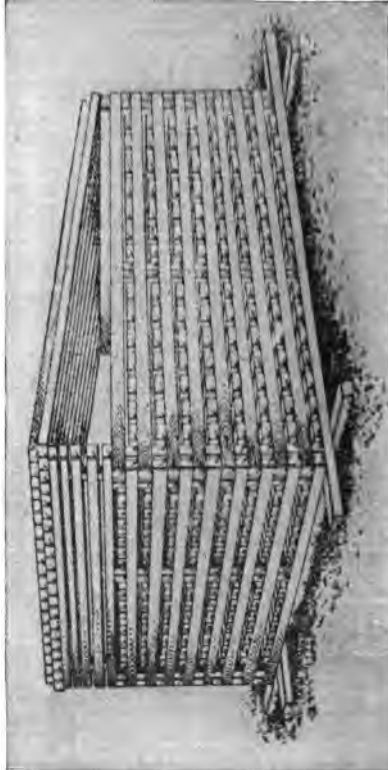

FIG. 334.—A 20 by 20 pile of cross-arms with a roof constructed of the arms themselves—not recommended.

parts of the United States throughout the greater portion of the year, it is best to expose the timber directly to the sun and rain. During the Winter months, however, or whenever there is a prevalence of rain or snow, excellent results will be secured by piling the arms under a roof, without walls, or by constructing a rude roof over

each pile. This latter method will probably be the cheapest, as it avoids the difficulty of handling the arms in a confined space. If the boards are placed as shown in Fig. 333, the arms below will remain dry during even a heavy rain or snow-storm. Of the two, snow is the more serious, since it generally takes longer to evaporate; and

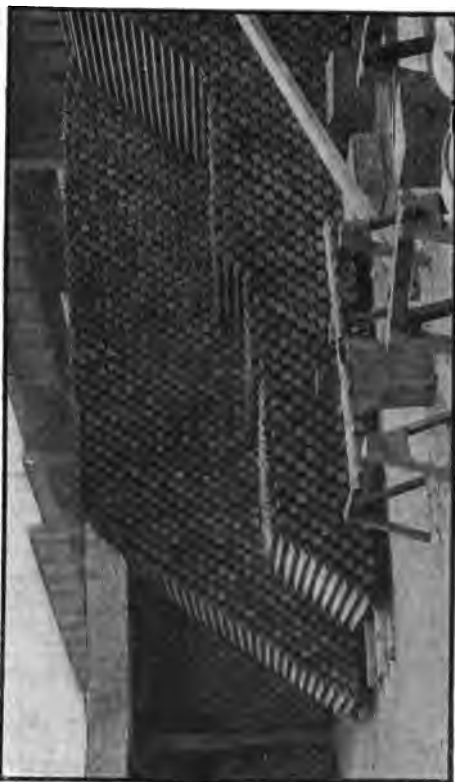

FIG. 335.—A method of cross-arm racking where pins have been assembled in arms.

during its slow melting the partially seasoned timber will absorb moisture without giving it off. In all cases, the roofing should extend out over the pile on all sides to protect the ends of the arms, for it is there that the evaporation or absorption of moisture is most rapid.

"It is not advisable to attempt to form the roof with the arms

themselves, as shown in Fig. 334, for three reasons: In the first place, the roof is too short and too narrow to give proper protection to the ends and sides of the pile; in the second place, the exposure of the roof arms to maximum changes of atmospheric condition causes severe checking and warping, with a consequent loss of timber; and, in the third place, considerably more labor is required to handle the greater number of pieces necessary in constructing the roof." Also see Fig. 335 for still another method of cross-arm racking.

The length of time necessary to effect sufficient seasoning of either poles or cross-arms decides whether the timber should be cut in the Winter or Spring. Wood that will season to the proper stage in approximately six months can safely be cut in the Spring, while that requiring a longer period should be cut in the Winter so as not to carry the seasoning stock over the late Fall and Winter. This is obvious, as timber cut in the Spring will receive the effect of the hot Summer sun, while the Autumn-cut timber must be held during the Winter months when the seasoning process is at its slowest stage. The United States Forest Service states that no poles should be cut in Summer or early Autumn, as the stumps of poles cut at that time will not give forth vigorous sprouts. Some experiments conducted recently in California by the Government show the following results in regard to seasonal cutting of western yellow pine and western red cedar (Tables 87 and 88).

**TABLE 87**  
**SEASONING OF WESTERN YELLOW PINE POLES,**  
**MADERA COUNTY, CALIFORNIA**

Month	AUTUMN CUT		WINTER CUT		SPRING CUT		SUMMER CUT	
	Weight per Cubic Foot Pounds	Per Cent of Green Weight Lost	Weight per Cubic Foot Pounds	Per Cent of Green Weight Lost	Weight per Cubic Foot Pounds	Per Cent of Green Weight Lost	Weight per Cubic Foot Pounds	Per Cent of Green Weight Lost
October....	64.1	..	..	..	..	..	..	..
November..	64.0	15.8	..	..	..	..	..	..
December..	61.3	20.0	..	..	..	..	..	..
January....	62.6	17.9	..	..	..	..	..	..
February...	64.1	16.6	66.6	..	..	..	..	..
March.....	60.4	21.4	62.6	6.0	..	..	..	..
April.....	46.0	28.2	56.2	15.6	65.2	..	..	..
May.....	41.7	35.0	47.7	28.4	51.5	21.0	..	..
June.....	37.6	41.4	40.4	39.3	44.4	31.9	..	..
July.....	33.7	47.5	36.0	45.9	39.8	39.0	64.8	..
August....	30.3	52.7	32.8	50.3	36.3	44.5	46.3	37.3
September..	..	..	..	..	32.6	50.0	33.8	47.3
October....	..	..	..	..	..	..	31.8	51.0

Average pole (40 feet) contained 26.1 cubic feet.

TABLE 88				
SEASONING OF WESTERN RED CEDAR POLES, LOS ANGELES, CALIFORNIA				
Weight per Cubic Foot Each Month from Time of Cutting.*				
Month	Summer Cut	Fall Cut	Winter Cut	Spring Cut
July . . . . .	42.4†	..	..	..
August . . . . .	..	..	..	..
September . . . . .	..	..	..	..
October . . . . .	..	42.4†	..	..
November . . . . .	..	..	..	..
December . . . . .	..	..	42.4†	..
January . . . . .	32.5‡	..	..	..
February . . . . .	31.1	..	..	..
March . . . . .	30.0	..	..	..
April . . . . .	28.5	..	36.12‡	42.4†
May . . . . .	26.5	33.0‡	28.25	..
June . . . . .	25.0	29.0	26.30	..
July . . . . .	23.5	26.5	25.3	36.12‡
August . . . . .	23.46	25.5	..	33.0
September . . . . .	..	..	..	31.0
October . . . . .	..	..	..	29.3
November . . . . .	..	..	..	28.0

\* The average volume of 300 poles (40 feet 8 inches) was 27.34 cubic feet.

† Absolute green weight.

‡ Weight on arrival at Los Angeles, California, from three to seven months after cutting.

TABLE 89								
RATE OF SEASONING OF CHESTNUT POLES CUT AT DIFFERENT TIMES OF THE YEAR								
	FALL CUT		WINTER CUT		SPRING CUT		SUMMER CUT	
Time Seasoned Days	Moisture Content Per Cent	Weight Per Cubic Foot Pounds	Moisture Content Per Cent	Weight Per Cubic Foot Pounds	Moisture Content Per Cent	Weight Per Cubic Foot Pounds	Moisture Content Per Cent	Weight Per Cubic Foot Pounds
0	85.4	56.4	85.6	56.4	83.0	5.6	84.4	56.1
30	72.0	52.3	77.4	53.9	70.5	51.8	67.9	51.0
60	68.4	51.2	72.6	52.5	64.3	49.9	60.6	48.8
90	66.9	50.7	68.7	51.3	60.0	48.6	57.5	47.9
120	65.3	50.4	64.8	50.1	56.5	47.6	55.9	47.4
150	64.3	49.9	60.6	48.8	53.7	46.7	..	..
180	62.2	49.3	56.8	47.7	51.7	46.1	..	..
210	59.2	48.4	53.7	46.7	..	..	..	..
240	56.0	47.4	51.2	46.0	..	..	..	..
270	53.0	46.5	49.3	45.4	..	..	..	..
300	50.8	45.3	..	..	..	..	..	..
330	49.1	45.3	..	..	..	..	..	..
360	47.3	44.9	..	..	..	..	..	..



Sec. 9

WOOD PRESERVATION

The preceding table taken from Forest Circular No. 147 shows the rate of seasoning of Maryland chestnut poles cut at different times of the year (Table 89).

To cover more fully general geographical conditions, the following, taken from United States Forest Service Circular No. 136 shows the rate of seasoning of Michigan arborvitæ poles by seasonal cuts:

**TABLE 90**  
**WEIGHT AND MOISTURE CONTENT BY SEASONAL CUTS**

Time Seasoned Days	SPRING CUT		SUMMER CUT		AUTUMN CUT		WINTER CUT	
	Moisture Content in Relation to Dry Weight Per Cent	Weight per Cubic Foot Pounds	Moisture Content in Relation to Dry Weight Per Cent	Weight per Cubic Foot Pounds	Moisture Content in Relation to Dry Weight Per Cent	Weight per Cubic Foot Pounds	Moisture Content in Relation to Dry Weight Per Cent	Weight per Cubic Foot Pounds
0	77.4	31.9	31.7	32.7	79.0	32.2	90.0	34.2
30	53.3	27.7	61.4	29.1	79.0	32.2	90.0	34.2
60	49.7	26.9	51.9	27.3	79.0	32.2	90.0	34.2
90	48.4	26.7	49.1	26.8	79.0	32.2	86.4	33.6
120	48.3	26.7	49.0	26.8	79.0	32.2	83.0	27.5
150	48.3	26.7	49.0	26.8	77.2	31.9	42.3	25.6
180	48.3	26.7	49.0	26.8	48.0	25.7	37.5	24.8
210	48.3	26.7	49.0	26.8	33.2	24.0	34.3	24.2
240	48.3	26.7	43.0	26.6	29.0	23.2	..	..
270	48.3	26.7	40.5	25.3	27.2	22.9	..	..
300	48.3	26.7	35.7	24.4	..	..	..	..
330	44.2	26.0	32.9	23.9	..	..	..	..
360	36.0	24.5	30.7	23.5	..	..	..	..
390	33.7	24.1	..	..	..	..	..	..
420	32.3	23.8	..	..	..	..	..	..

The following tables were taken from Forest Service Circular No. 151. They show the green weight according to the season when cut and the comparative rates of seasoning of North Carolina loblolly pine, heart-wood, sap-wood and intermediate grade cross-arms (Tables 91 and 92):

**TABLE 91**  
**COMPARATIVE WEIGHTS OF GREEN NORTH CAROLINA LOBLOLLY PINE**  
**WEIGHT PER CUBIC FOOT**

Portion of Tree	Autumn Pounds	Spring Pounds	Summer Pounds	Winter Pounds
Heart-wood.....	42.4	42.6	45.1	45.5
Intermediate.....	48.8	49.9	50.2	51.1
Sap-wood.....	55.6	57.4	57.4	58.2

Days Seasoned	HEART-WOOD			SAP-WOOD			INTERMEDIATE		
	Weight Per Arm Pounds	Weight Per Cubic Foot Pounds	Moisture Content Per Cent	Weight Per Arm Pounds	Weight Per Cubic Foot Pounds	Moisture Content Per Cent	Weight Per Arm Pounds	Weight Per Cubic Foot Pounds	Moisture Content Per Cent
0	35.8	42.6	51.5	52.7	57.9	105.8	45.8	50.3	79.0
30	34.2	37.6	33.4	34.5	37.9	34.8	34.3	37.7	34.0
60	33.9	37.3	32.5	32.6	35.8	27.2	33.3	36.6	30.0
90	34.3	37.3	33.8	32.6	35.8	27.3	33.4	36.7	30.3
120	34.2	37.6	33.7	32.5	35.7	26.9	33.4	36.7	30.3
150	33.9	37.3	32.3	32.1	35.3	25.4	33.0	36.3	29.0
180	33.6	36.9	31.2	31.6	34.7	23.6	32.5	35.7	26.9

The foregoing Government tests conducted in California on western yellow pine and western red cedar would indicate that the yellow pine should be air-dry and ready for preservative treatment when it had lost 50 per cent of its original weight, and that the red cedar should lose 40 per cent of its original weight before treating. Chestnut poles should be ready to set or to receive brush treatment when they have lost about 15 per cent of their original weight. According to Forest Service Circular No. 136, the air-dry weight of arborvitæ should be about 73 per cent of the green weight, or a loss of 27 per cent of its original weight.

The above data are given to illustrate the seasoning characteristics of some of the more representative types of wood. The Government tests cited were selected because of their undoubted accuracy.

**6. Summary on Seasoning.\*** 1. Poles should be cut from sound standing timber.

2. The bark should be well peeled from poles which are to be seasoned, and particularly from those that are to be treated, as the inner bark offers much resistance to the impregnating fluid, and in time this bark peels, leaving the untreated wood exposed to the attack of fungi.

3. Care should be taken in the handling and felling of trees, as those which are split in felling, or are otherwise roughly handled, may afterwards experience serious checking.

\*For further data, see Bulletin No. 84 of the Forestry Service.

## Sec. 9

## WOOD PRESERVATION

4. Poles and crossarms should be properly piled and stored, and as soon after cutting as possible.

5. The amount of shrinkage during seasoning is negligible.

6. Poles cut in the Winter or Spring have before them the best period for seasoning, but late Fall and Winter offer the best conditions for cutting.

7. Attention should be paid to the value of having wood seasoned where cut, as a material freight-saving may often be made in this way.

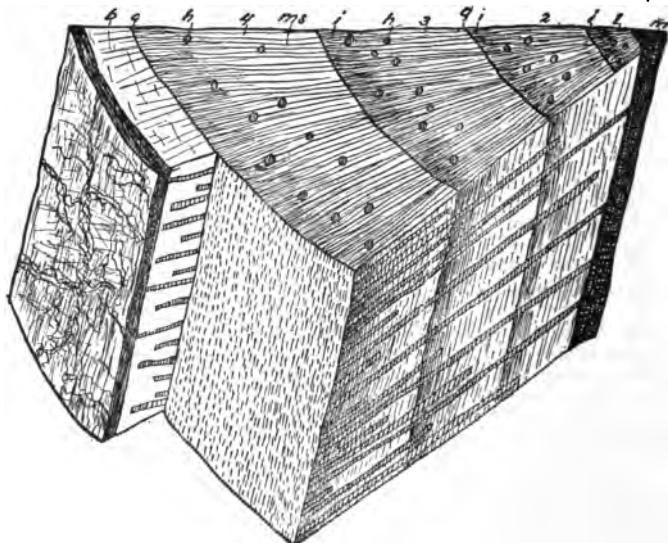

FIG. 336.—Portion of stem of four-year-old pine, *Pinus Sylvestris*, cut in winter. (q), transverse view; (l), radial view; (t), tangential view; (f), early wood; (e), late wood; (m), medulla; (p), protoxylem; (1, 2, 3, 4), the four successive annular rings of the wood; (i), junction of the wood of successive years; (me, ma', ma''), medullary rays in transverse, radial, and tangential views; (ms'') radial view of medullary rays in the bast; (c), cambium ting; (b), bast; (h), resin canals; (br), bark.

### PRESERVATIVES

7. **General.** In order to understand the physical and chemical action of preservatives in preventing or retarding decay, it will be necessary to consider somewhat the structure of wood, the nature of the phenomena which take place when decay sets in, and the causes underlying the coincident physical and chemical changes in the wood structure resulting finally in its more or less complete destruction.

8. **Structure of Wood.** From a chemical standpoint, the predominating material which enters into the composition of wood is

cellulose. The other non-cellulose materials present are known as the lignone complex. The latter includes resins, gums, coniferine, tannin, etc. Physically, wood is made up of small organs resembling honeycombs in appearance, but much smaller. (Fig. 339.) These organs are known as wood-cells. They are surrounded by distinct stiff walls and are thus sharply separated from one another. The



FIG. 337.—Tangential section of the late wood of pine. (t), Bordered pit; (tm), tracheidal medullary ray cells; (sm), medullary ray cells containing starch; (et), bordered pit only on one side; (i), intercellular space in the medullary ray.

canals from adjoining cells constantly meet and are sometimes widened at their base into bordered pits (Fig. 337). The most important constituent of these cell-walls is cellulose. It is present in the cell-walls of most plants, except the fungi. The cell-wall is a product of protoplasm, and it never consists of cellulose alone, but contains a considerable amount of other substances which are not of a cellulose character.

**Lignification** (stiffening of the cell-walls) is brought about by the deposition of coniferine, vanillin, and other materials in the cell-wall. After lignification, cell-walls are permeable to water and gases. However, if cutin is subsequently deposited in the cell-walls,

which have already been lignified, they are rendered impervious to gases and to water. While the cells of woods vary to some extent, those which are provided with bordered pits and are not sharpened at the ends are spoken of as tracheids (Fig. 338). These contain water, acting as water-carriers for the tree. When they become inactive they are full of air. It must be remembered that these tracheids are extremely small. Tissues result from an intimate union of an aggregation of cells. These cells may fit closely to-

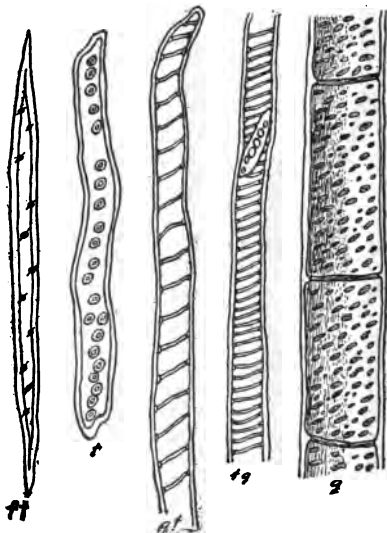

FIG. 338.—(t), Tracheid having large bordered pits which act as water carrier; (gt), vascular tracheids with similar functions, but with the structure and thickenings of vessels; (ft), fibre tracheids with small lumina and pointed ends, having only small, obliquely elongated bordered pits, and, in extreme cases, exercising merely mechanical functions; (g), tracheæ, formed by cell fusion, and provided with all the different forms of thickenings by which they are distinguished as annular, spiral, reticulate, or pitted vessels. All vessels function as water carriers. If they have small lumina and resemble tracheids they may be distinguished as tracheidal vessels.

gether, thus leaving no openings or intercellular spaces between them. In case the cells are not so closely fitted together, intercellular spaces result (Fig. 337).

By reason of variations in climatic conditions, the woody tissue

\* Figs. 336, 337 and 338 reproduced from "A Textbook of Botany," by Strasburger and others.

† Figs. 339, 340 and 341 taken from Bulletin No. 1 of the Division of Forestry.

exhibits variation in size and extent of growth, and it is in consequence of such variations that **annular rings** result (Fig. 336). During the Spring, when energetic growth takes place, larger trachial ele-

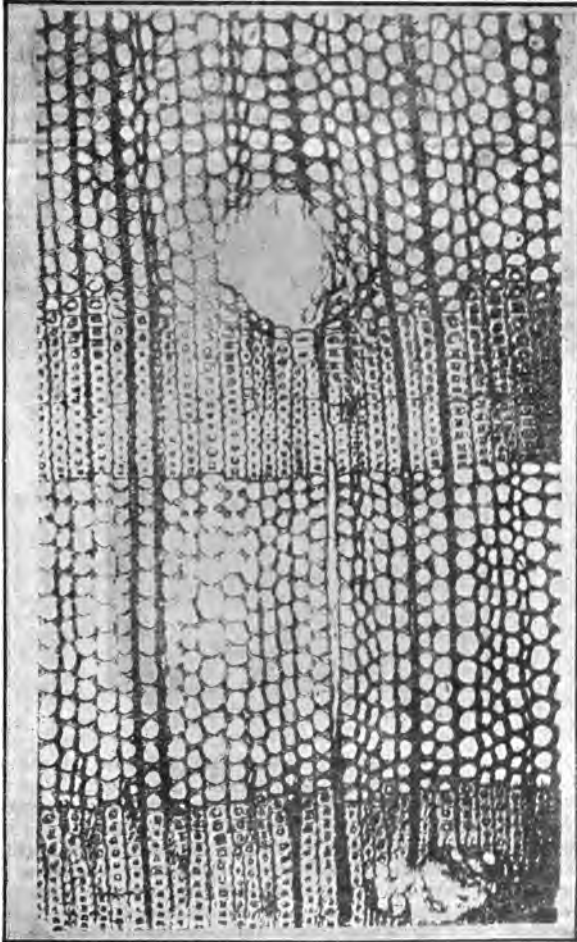

FIG. 339.—*Pinus Palustris*, Miller; Long-leaved Pine Transverse Section.

ments are developed than during the Fall and Winter season. A difference is therefore noticed between Spring wood, which is made up of very large tracheids, and Autumn wood, which consists of narrow ones. It must be remembered that the tissue, which is made up of tracheids, is, in its fully developed condition, composed of dead-cell cavities devoid of any living content.

9. Sap-wood is composed of cells which go to make the more recent annular rings. These cells are living organisms and act as water-carriers of the tree (Fig. 338). Before these living cells die and enter into the formation of dead tissues they produce certain

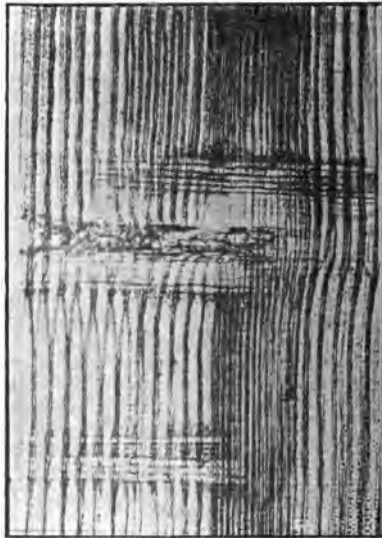

FIG. 340.

substances, such as gums and tannins, which penetrate the cell-walls and also close, or partly close, the cavities. These tannins are said to prevent the decay of the wood, while the gums are supposed to close the cells and thus end their function as water-carriers. These tissues, composed of dead cells which are impermeable to water, go to make up heart-wood. It will be readily seen why heart-wood is so resistant to decay and why it is almost impossible to penetrate it by means of impregnating materials. Heart-wood can usually be distinguished from sap-wood by its darker color, indicative of the presence of gums or tannins. In some trees, notably the willow,

these protective materials are absent, and the heart of willow trees is, in consequence, usually decayed, finally becoming hollow.

10. Decay is the change which takes place under the influence of certain agents, resulting in the decomposition or breaking-down of complex into simpler bodies. The decay of wood is generally due to the activities of certain low forms of plant life known as fungi. Bacteria are also known to cause decay, but their action is little understood, and in order to illustrate the manner in which these organisms promote decay a description of the fungi will suffice.

These plants have their origin in minute spores borne from place



FIG. 341.

to place by the wind. Those that lodge and find a suitable situation for growth, which may be on living or dead timber, germinate, provided the conditions are favorable, and at once attack the wood, drawing their sustenance partly from the atmosphere and partly from the contents of the wood-cells; and they finally attack the cell-walls, resulting in the breaking up of the complex chemical substances and the liberation of various gases; the result being the reduction of the wood into a mass having little or no resemblance to the original material.



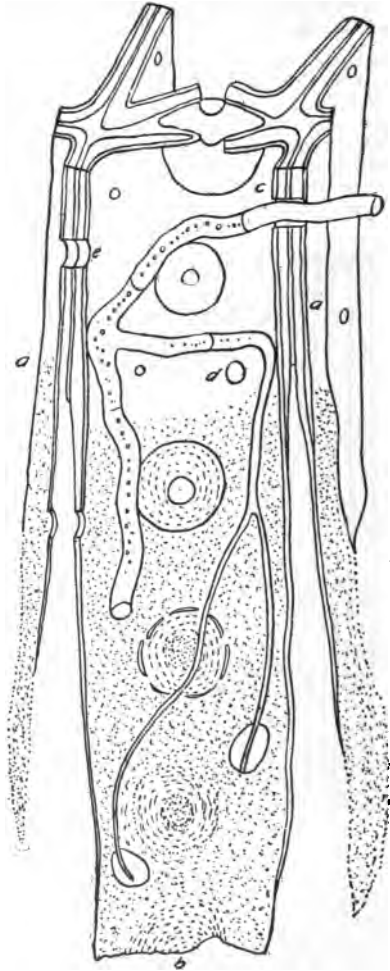

FIG. 342.—Tracheid of *Pinus sylvestris*, decomposed by *Trametes Pini*. The primary cell-wall has been completely dissolved as far as a. In the lower part the secondary and tertiary layers consist only of the cellulose, in which lime-granules are distinctly visible, b; filamentous mycelia, c, penetrate the walls and make holes as at d and e.

The action of the various forms of fungi is quite similar. They grow with great rapidity, sending out numerous threads which penetrate into the wood and attack the contents of the cells—the sugars, starches and oils—and finally the cell-walls. These thread-like bodies are called hyphae, and aggregations of them form the mycelium. In Fig. 341 will be seen the filamentous mycelia of the *Trametes Pini*. The gradual decomposition of wood by these fungi is shown in Fig. 342. When sufficient food has been absorbed, the hyphae form a fruiting body (Fig. 343 and Fig. 344) which bears a crop of spores, which in turn again produce the mycelium of decay. Familiar instances of these fruiting bodies are the punks and toadstools seen on decaying wood. The most favorable conditions for the growth of fungi and other organisms of decay are an abundant food supply, heat, moisture, and air, the amount of each required being dependent upon the kind of organism. A certain amount of moisture must be present or decay cannot set in. Air is also essential, and thus may be explained the lasting qualities of wood when kept perfectly dry, and the perfect state of preservation of wood which has been under water for long periods; moisture being lacking in the first case and air in the second. Again, if the wood is rendered unfit for use by an antiseptic\* or is protected by a germicide, it will not decay. A familiar example, serving well to illustrate the foregoing, is the rotting of fence-posts and telephone, telegraph, and other poles in the zone extending from just below to just above the ground line. At the base of the pole, while moisture is present, air is excluded, while above the ground the pole is generally dry. It is where moisture and air are both present, the former being drawn by capillary attraction from the ground, that decay begins.

Before considering the action of preservatives, it may be well to emphasize these axioms:

**Decay is induced by the action of living organisms.**

**Moisture, air, food, and a certain amount of heat are absolutely necessary for the growth of these organisms.**

**Perfectly dry wood will not decay.**

**Wood kept under water will not decay.**

**Wood saturated with a substance which will act as a germicide will not decay.**

**Wood saturated with a substance which will act as an antiseptic will not decay.**

**11. PRESERVATIVE AGENTS.** A theoretical consideration of the conditions under which decay may start suggests the remedy in the introduction into the wood of some substance which will act as an antiseptic or a germicide, or prevent the entrance of moisture or air. Materials that have been found to possess one or more of these desirable qualities may be classified under two general headings—

---

\*An antiseptic here is understood to be any substance which will inhibit the growth of fungi, while germicides are understood to be substances which are active poisons to these growths.

**oils and salts.** The most important of the oils are coal-tar creosote or dead oil of coal-tar, coal-tar anthracene oil, water-gas tar dead oil, and other heavy fractions therefrom, petroleum and petroleum residues, and wood creosote. Of the salts, zinc chloride, mercuric chloride, and copper sulphate are the most extensively used.

It is generally believed that all of these substances are capable of insuring one or more of the conditions necessary to prevent decay, provided, always, that the wood remains saturated with the preservative. The chief difficulty is encountered when it is required to decide upon the extent of treatment necessary to insure the desired length of life, it being obviously inadvisable to preserve the timber beyond its mechanical life. This consideration, however, is much more important in treating railroad ties than in treating poles and cross-arms, for the reason that the latter are subject to little mechanical wear. Another important consideration is the kind of preservative best suited for a particular situation. Climatic and soil conditions, in some situations, make it inadvisable to use a preservative which, in another situation, would prove perfectly satisfactory. For example, in certain sections of the country where there is a great amount of rainfall, zinc chloride treatments are likely to prove inefficient on account of the leaching out of the soluble zinc chloride. On the other hand, there are many situations where it could be used to advantage both in respect to cheapness and efficiency.

These are important economic considerations, and the various processes which have been evolved, some employing antiseptics, others germicides, and still others offering only mechanical protection against the entrance of moisture or air or both, result from the desire to obtain the maximum protection with a minimum expenditure of time and money.

It may be well here to state that, as a rule, the more of the preservative injected per cubic foot the greater the life of the timber is likely to be. It may be, and probably is true, in a great many instances, that the employment of a small amount of preservative, whether by shallow penetration, as in the open tank and brush treatments, or by the withdrawal of a portion of it after it is placed in the wood, as in the empty cell processes, or by its loss by evaporation or solution, will furnish a sufficient amount of protection. However, where long protection is of paramount importance, deep full-cell penetrations are undoubtedly the best.

**12. Preservation with Oils.** Whatever difference of opinion may exist in the minds of those interested in the subject as to the relative merits of other preservatives, one and all agree that coal-tar creosote oil, when properly applied, will protect timber against decay for an indefinite period, usually far in excess of its mechanical life, and it is therefore regarded as the ideal preservative and a standard by which all others must be gauged. The reason for this is due primarily to the fact that time, the all-important factor in the field of wood preservation, has demonstrated its value under most variable and trying conditions. There are numerous well-authenticated in-

stances of timber being preserved by creosote oil for periods of time, in some cases amounting to 30 or even 40 years; a notable example being a Baltic redwood tie removed from the tracks of the Glasgow and Southwestern Railway, in Scotland, in a perfect state of preservation after 42 years of service. There still remained in the tie over 12 pounds of creosote oil per cubic foot.

While it is probable that the controlling factor governing the first use of this oil was that it could be obtained in large quantities at a reasonable cost, theoretical considerations to-day, based on our more advanced knowledge of the causes underlying decay, indicate that the chemical and physical characteristics possessed by coal-tar creosote oil make it well worthy of the high esteem in which it is held, and places beyond the bounds of probability any suggestion that the long life of timber treated with this preservative may have been due to other causes.

**13. Coal-Tar Creosote.** Owing to its importance in timber preservation, as well as to illustrate the relation existing between it and other oils now being used for this purpose, a more or less detailed description of the manner in which it is produced may not be out of place.

In the manufacture of illuminating gas, by the destructive distillation of coal in closed vessels, coal-tar is produced as a by-product. It is also produced as a by-product in the operation of retort coke ovens. The difference in the physical characteristics of the tars produced in the two operations is so slight that one may easily be mistaken for the other, and chemically they are identical, containing the same constituents, but in somewhat different proportions.

At gas works, the coal is carbonized in externally heated fire-clay retorts capable of working off a charge of from three to four hundred pounds of coal every four hours, while at by-product coke ovens the charge amounts to several tons, and the duration of the carbonizing period may be from 18 to 30 hours. This difference in method of carbonization has some influence, as stated above, on the quality of the tar, and therefore on the oils distilled therefrom.

Bituminous coal containing a considerable amount of volatile matter is used in these operations. That used in the manufacture of gas by the retort method may contain as much as 35 to 40 per cent, while that used in coke ovens usually contains somewhat less.

The residue remaining in the retort or oven, as the case may be, constitutes coke. It is from the volatile matter which is driven off that illuminating gas and tar are produced.

This volatile matter consists of permanent gases, such as ethylene and its homologues, hydrogen, marsh gas, carbon monoxide, oxygen, nitrogen, etc., which carry in suspension vapors of various other hydrocarbons, whose boiling points cover a considerable temperature range. A slight reduction in the temperature of the carrying gas causes a partial precipitation of the suspended hydrocarbons, and since a gas which will be suitable for illuminating purposes must be permanent under ordinary conditions, it is necessary to free it more

## Sec. 9

## WOOD PRESERVATION

or less completely of suspended matter. The readiness with which the hydrocarbon vapors precipitate upon even a slight reduction in temperature is taken advantage of to free the gas of their presence, the operation being assisted by the use of condensers and scrubbers. The condensed liquid is known as coal-tar.



FIG. 343.—Fruiting body on chestnut fence post.

A chemical examination of coal-tar shows it to be largely made up of hydrocarbons of the closed ring or aromatic series, prominent among them being benzol, toluol, xylol, naphthalene, carbolic acid, anthracene, etc., which have been formed by the high heat to which the coal has been subjected. If the coal is carbonized at a low heat, the character of the hydrocarbons is much changed. In this case,

the paraffin series, such as occur in petroleum oils, will be present in considerable quantities.

It should be borne in mind that the hydrocarbons found in coal-tar do not exist in the coal as such, but are formed by breaking down and polymerization of other hydrocarbons, notably of the paraffin series. To quote a well-known authority, "The hydrocarbons



Fig. 344.—Fruiting body growing on oak railroad tie.

produced by the use of a comparatively low temperature are mostly paraffins (hydrocarbons of the methane series) with some olefines. At a higher temperature the paraffins, except methane, disappear, and are replaced by olefines—ethylene, propylene and butylene. At a still higher temperature acetylene appears, accompanied by

benzene,  $C_6H_6$ . These are followed by naphthalene,  $C_{10}H_8$ , chrysene, pyrene, diphenyl, etc."

At one time coal-tar was a waste product, in fact its accumulation created a nuisance with which it was for a long while difficult to cope. The discovery, however, by Sir William Perkin, that some of its constituents could be used as bases for very valuable dyes opened up a field which has developed along this and other lines to such an extent that tar distillation has become an important industry, and there are at the present time few, if any, compounds obtainable from coal-tar that are not commercially valuable.

It is customary in the first distillation of coal-tar, which is carried out in externally fired stills, varying in capacity from a few hundred to several thousand gallons, to make a preliminary more or less crude separation of the volatile portions of the tar into several fractions. The first, or light oil fraction, constitutes the raw material from which are obtained benzol, toluol, and solvent naphtha. This cut is made at about 170 degrees Centigrade (338 degrees Fahrenheit). A second cut at about 230 degrees Centigrade (446 degrees Fahrenheit) includes the middle oils, which contain a large portion of the tar acids and naphthalene. A third cut at 270 degrees Centigrade (518 degrees Fahrenheit) includes creosote oil. The residue remaining in the still may be hard or soft pitch, depending upon the extent to which the heavier fractions are removed. If the distillation is carried to hard pitch, heavy anthracene oils are recovered after the creosote oils. The accompanying diagram graphically illustrates the position which creosote oil bears to the other products obtainable from coal-tar.

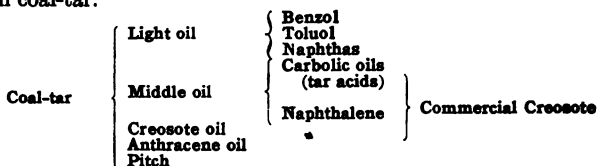

Since creosote oil is a mixture of various oils it is not, even under the best conditions, of invariable quality, and under conditions usually met with a uniform grade is difficult to obtain at a price which would not be prohibitive. There are several reasons for this. In the first place, the carbonization of different kinds of coal will affect, to a certain extent, the character of the tar and necessarily, therefore, of the oils distilled therefrom. Then it is the practice of some tar distillers to carry the distillation farther than others, e. g., it is the usual practice abroad to make hard pitch, which means that there will be relatively more of the high-boiling anthracene fractions left in the creosote oil than when soft pitch is made, as is the usual practice of American tar distillers. Another factor operating against uniformity is that creosote oil usually commands the lowest price of the oils produced in a tar distilling plant, and it is customary,

therefore, to extract from the heavy oil fraction the products which, at the time, are more valuable than creosote. It may happen that the demand for naphthalene is slight, and therefore the price which can be obtained for it low. At such times it is usually left in the creosote oil and sold for wood preservation. When the market for naphthalene changes for the better it may be recovered, with the attendant change in the composition of the creosote oil. It is a common practice, also, to run residues and other oils of relatively low value into the creosote oil tank; in other words, it is the receptacle for the low-grade oils produced by the plant. In spite of this, the preservative value of the oil is such that ample protection against decay has been procured when a sufficient quantity of the oil was injected. Owing to the steadily growing progress being made in the art of wood preservation with the increasing knowledge of what constitutes the best grade of creosote oil, large consumers are now purchasing under specifications, with the object in view of eliminating that portion of the oil which will be lost by volatilization or solution, either during the process of treatment of the timber or after it is placed in service, and of insuring in the oil the amounts of those constituents which they deem most suitable for their particular purpose. Opinions differ greatly as to which are the most important constituents of creosote oil. There are some who maintain that the tar acids, which are germicides, are the most important constituents. Others contend that naphthalene is the most valuable, attributing its efficiency to its antiseptic qualities or to its crystallization in the pores of the wood, preventing entrance of moisture and keeping in the lighter portions of the oil. Still others claim that it is the heavy anthracene oil fractions that are of the most value, these oils losing little by volatilization and solution, and effectively excluding moisture and air. Antiseptic powers are also claimed for them by many.

Considerable light has recently been thrown on this subject by the Forestry Service.\* Some forty specimens of creosoted timber that had successfully resisted decay for from 10 to 40 years were examined, and it was found, in every instance, that the tar acids had either disappeared entirely or been reduced to less than 1 per cent, and that the constituents of the oil which had remained in the timber represented the naphthalene, anthracene, and other high-boiling fractions.

The value of such oils is now generally conceded, but their high price restricts their application for full-cell treatments. These high-boiling oils constitute in whole, or in part, many of the well-known high-priced preservatives. When such oils are once gotten into the wood there is little chance of loss by volatilization, and for this reason their value is greater than that of the ordinary grades of coal-tar creosote. Such high gravity oils have their application in brush and dipping treatments referred to in another portion of this report,

---

\* Bulletin No. 98.



Authorities are now generally agreed that the value of light oils and tar acids is of minor importance compared with the heavy fractions. It is perhaps safe to say that those oils coming off below 205 degrees Centigrade (401 degrees Fahrenheit), when distilled by one or other of the standard methods commonly employed in this country in which the thermometer indicates the temperature of the vapor, will be lost, either during treatment or after the timber is put into service.

**14. Water-Gas Tar Creosote.** While the value of other oils for wood preservation is not so well established as that of coal-tar creosote, owing to the fact that time alone can furnish absolute proof, theoretical and other considerations point to the fact that oils distilled from water-gas tar may be of equal value. If such is the case, it will do much to relieve the difficulty in securing suitable oils, since two-thirds of the gas used for illuminating purposes in the United States at the present time is water-gas, and about 75,000,000 gallons of tar are made as a by-product of its manufacture.

On account of the well-known preservative value of coal-tar creosote and its relatively higher cost, oils of other origin are generally looked upon as adulterants, and while the preservative value of the coal-tar creosote may not have been lessened by the admixture, the practice constitutes a fraud if the material is sold as straight coal-tar creosote. In Bulletin No. 78 of the Forest Service, the following statement is made:

"Petroleum-tar creosote is already used in large quantities, most of it being sold not under its own name but as an adulterant of coal-tar creosote. It contains some of the most important constituents of coal-tar creosote as well as those of the paraffin series. Its analysis by fractional distillation is sometimes identical with that of the coal-tar product, and it is probable that after injection into timber it would show no more rapid volatilization."

In this Bulletin no distinction is made between water-gas tar creosote and creosote produced from tars formed in the process of making oil-gas as in the Pintsch or the straight oil-gas systems, although the chemical constitution of tars produced in making oil-gas is quite different. Since, however, very little of this tar is made, the reference is undoubtedly to water-gas tar.

The manner in which water-gas tar is produced from petroleum, explains its striking similarity to coal-tar. In this process "blue gas," which consists of a mixture of carbon monoxide and hydrogen, obtained by passing steam through a bed of incandescent coal or coke, is passed into a chamber containing checker brick heated to a high temperature. There it is carburetted by the oil-gas resulting from the cracking up of petroleum oil which is fed into the chamber. Thence the carburetted gas is passed into a second chamber similarly constructed, and there subjected to further heat, which more or less completely finishes the transformation of the paraffin hydrocarbons contained in the petroleum oil into hydrocarbons of the closed ring or aromatic series similar to those found in coal-tar. Naphthalene

and all other compounds, except the oxygenated "tar acids," are produced; the production of these latter being prevented probably by the reducing effect of the carbon monoxide and hydrogen present in the "blue gas." If the heat is sufficiently high and the contact with the checker brick sufficiently prolonged, there will be practically no uncracked paraffin oil in the tar, and this is likely to be the case in the best operated works, because the presence there of uncracked oil means inefficient and uneconomical operation of the machines.

Water-gas tar is now employed in the production of benzol, toluol, solvent naphtha, naphthalene, and other similar compounds heretofore obtained almost exclusively from coal-tar; and exhaustive examinations of the high-boiling fractions reveal the presence of methyl and dimethyl anthracene, phenanthrene, and other constituents found in coal-tar. Owing to the absence of tar acids, it is impossible to say, at the present time, whether the oil is a germicide. It is an antiseptic, and there is not the least doubt that there may be procured from it an oil of high gravity which should remain in the wood-cells indefinitely. Such being the case, its value should be equal to that of coal-tar creosote.

Owing to the comparatively short time in which this oil has been on the market, the only well-authenticated test is of but three years' duration. In this instance it was placed in comparison with coal-tar creosote and zinc chloride in the Silver Creek Colliery of the Philadelphia and Reading Coal and Iron Company, being used in protecting mine timbers. At the present time there appears to be no difference in the results of the three treatments, all of the timbers being perfectly sound, while the untreated timber was completely destroyed in 15 months.

The following statement in a recent article written for the Forest Service is also of interest in connection with this oil:

"It is from the distillation of water-gas tar, under certain rather rigid conditions, that consumers of creosote in this country will have to look for increased supplies. Providing that such creosote is distilled from a tar produced in the manufacture of illuminating gas by the Lowe or similar process, and from crude oils containing asphalt base, and provided that the proper fraction is collected on distillation, it very closely approximates a straight run coal-tar creosote. The main difference is the almost complete absence of phenol, cresols, or homologous 'tar acids.' The naphthalene content of either coal-tar creosote or water-gas dead oil, distilled under similar conditions, is generally about equal, so that where (as some specifications demand) this product is required, and the content of tar acids not considered of importance, either oil is valuable provided the specific gravity is sufficiently high and distillation results satisfactory."

Since no tar acids can be recovered from water-gas tar oils, it is possible to obtain a much more uniform creosote oil from this tar than from coal-tar, and where a distillation is carried to coke, as is sometimes done, straight run oil may be obtained of any gravity

between 1 and 1.12 and within such distillation limits as to preclude the possibility of loss by evaporation.

**15. Petroleum Oil.** It appears from the success met with on the Gulf, Colorado & Santa Fe Railroad, in using crude petroleum for protecting railroad ties against decay, that this oil may be of great value in wood preservation. A test was started in 1902, and the ties treated with Bakersfield oil, to the extent of 23 to 82 pounds per tie, are still in a good state of preservation. The Santa Fe Railroad is now operating a tie-treating plant using this material. It is probable that the oil has no germicidal action and that its value is dependent upon the protection offered against entrance of moisture.

**16. Wood Creosote.** The use of wood creosote for timber preservation is very limited, and the results that have been obtained are of uncertain value, owing to the fact that in the majority of cases it was applied by the brush or dipping process and very few records have been kept.

A test started in 1905 by the United States Forest Service, in the treatment of telephone poles, employed wood creosote as one of the preservatives. Sufficient time has not elapsed, however, to make any definite statements with reference to its probable value. It is possible, however, that if it is injected into the wood in sufficient quantities it will offer adequate protection. Its high cost, accompanied with its unknown value as a preservative, will, however, restrict its use.

The table on following page will show, at a glance, the chief difference between coal-tar creosote, water-gas tar creosote, wood creosote, petroleum-tar oil and petroleum oil. (Table 93.)

**17. Preservation with Salts.** The comparatively small use being made of salts in the treatment of poles and cross-arms renders it unnecessary to describe these preservatives at this time, particularly so since, being perfectly definite chemical compounds, a description of them may be obtained from any chemical dictionary or work on inorganic chemistry.

**18. Summary on Preservatives.** The choice of the proper preservative is dependent, in a great measure, upon local conditions. Full-cell treatments, with a **high-grade creosote oil**, will insure the maximum protection, but it is by no means uncertain that full-cell treatments with petroleum oil or other heavy oils will not offer an equal amount of protection. The chief danger in employing such oil would lie in not using it in quantities sufficient to keep out moisture or air.

It would seem that an entirely satisfactory oil, having antiseptic qualities, can be obtained from the distillation of water-gas tar, and as this material may be readily obtained, its general use would do much toward solving the difficulty of obtaining suitable oils at a reasonable cost.

While from a theoretical standpoint the use of **metallic salts** cannot be recommended for poles and cross-arms on account of

TABLE 93  
COMPARISON OF OIL PRESERVATIVES

Coal-Tar Creosote	Water-Gas Tar Creosote	Wood Creosote	Petroleum-Tar Oil and Petroleum Oil
<p>Coal-tar creosote is produced from tar resulting from the destructive distillation of bituminous coal. Such tars, ordinarily, consist entirely of hydrocarbons of the aromatic or closed ring series, such as benzene, toluene, xylene, naphthalene, phenanthrene, anthracene, methyl and dimethyl anthracene; oxygenated compounds (tar acids), such as phenol, creosol, and so forth. The creosote oil made therefrom contains those constituents of the tar derived from the heavy or dead oil fraction, such as tar acids, naphthalene, anthracene, and so forth. If the tar is produced at a low temperature, the creosote oil may contain some paraffin hydrocarbons. The oil is strongly antiseptic and germicidal.</p>	<p>Water-gas tar creosote is produced from tar resulting from the cracking up of petroleum oil at high temperatures in the presence of carbon monoxide and hydrogen. The chief differences between this tar and coal-tar is that, owing to the reducing effect of the hydrogen, it contains no tar acids, but probably contains all of the other closed ring hydrocarbons. No paraffin hydrocarbons are present if the tar is made under the best operating conditions. It is antiseptic and probably germicidal.</p>	<p>Wood-tar creosote results from the distillation of wood tar. It is a complex mixture of phenoloid bodies; the portions of which differ according to the mode of distillation and purification. Phenol is present in wood-tar creosote in very small quantities, but the two chief constituents are guaiacol and creosol. It is quite unlike coal-tar or water-gas tar creosote, but has strong antiseptic properties.</p>	<p>The oil resulting from the distillation of petroleum tar consists chiefly of uncracked portions of the original oil, and therefore differs little from petroleum oil. The predominating hydrocarbons are of the paraffin series, though naphthenes are present to a large extent in the asphaltum base oils. The oil is probably not a germicide. It may act, however, as an antiseptic in excluding moisture or air.</p>

their solubility, still, in view of the exceptional results obtained in Germany by the use of copper sulphate and mercuric chloride, it is impossible to say that these cannot, at times, be used to great advantage. It is recommended, however, when salt treatments are employed, that they be protected against leaching by creosote or some such similar method, and also that due caution be exercised in choosing this method of treatment.

Since much of the treating which will be done for the members of the National Electric Light Association is likely to be by the open-tank process, special attention should be paid to specifications covering suitable oils, it being remembered that a large part of the oil distilling under 200 degrees Centigrade is likely to be lost by volatilization during the process of treatment, thus greatly increasing the cost. The oil to be used in the open tank should constitute the higher boiling portions of the tar.

### PROCESSES

19. **General.** There are several causes underlying the rapid development which has resulted in the modern, highly efficient processes for impregnating timber with preservatives. The most important, perhaps, was the early recognition of the fact that, however great might be the value of a preservative in retarding or preventing decay, from a theoretical standpoint, its practical efficiency was likely to be largely dependent upon the extent to which it was driven into the timber. For this reason, the early methods of steeping the timber in the cold preservative contained in an open tank or vat was soon almost entirely superseded by processes insuring deeper penetration. Another important factor underlying this development was the growing demand made upon commercial plants for treated timber, coincident with the recognition of the great economic value of timber preservation and the urgent necessity for husbanding the diminishing supply of timber suitable for railroad and other purposes.

As in other branches of business, increased demand on the part of the consumer resulted in increased effort on the part of the treating plants to turn out a maximum amount of satisfactory work in the shortest possible time, while reducing the cost to a minimum. The greatest aid in the achievement of this end has been the employment of artificial pressure in injecting the fluid, it being found that by its use deep penetration could be gotten in a comparatively short time.

Owing to the heavy cost of installing high-pressure systems, however, there are comparatively few privately operated plants in the United States, and for this reason the small consumer of treated timber must either purchase from the large commercial plants, often so remote as to make the cost almost or quite prohibitive, or treat locally by a less costly process. To meet the demands of this class, as well as of those who desire only a moderate protection at a small cost, the United States Forest Service has devoted considerable time to the development of the open-tank or low-pressure system, and has brought its efficiency to such a degree that in many instances

it is possible to obtain adequate protection at a very low cost. Such plants can usually be operated by unskilled labor, require no expensive apparatus, and involve a very small initial investment.

All processes for treating timber may be considered under three heads—high artificial pressure systems, the atmospheric pressure systems, and the low artificial pressure systems; the first including most of the commercial plants, the second and third, the small individual plants.

The following table contains a classification of the most important systems, which are described in more or less detail further on. Some of them cannot be recommended for the treatment of poles or cross-arms, but it is felt that the whole field should be reviewed as a matter of general interest:

High Artificial Pressure Systems .....	Full Cell	Bethell
		Burnett
	Empty Cell	Wellhouse
		Rütgers
		Card
		Allardyce
Atmospheric Pressure System .....	Full Cell	Steeping in cold preservatives
		Steeping in hot preservatives
	Empty Cell	Alternate hot and cold treatments
		Hot, cold and hot treatments
Low Artificial Pressure Systems .....	Full Cell	Hot and graded cooling treatment
		Empty Cell

**20. HIGH ARTIFICIAL PRESSURE PROCESSES.** High-pressure processes may be either full cell or empty cell, depending upon whether or not the full amount of preservative injected into the timber is left in the cells or a portion subsequently withdrawn. The advocates of the full-cell treatments claim that unless the full amount of the preservative is left in the timber, sufficient protection against decay will not be afforded; while the advocates of the empty-cell treatments claim that, provided the penetration is deep, it is only necessary to leave a thin coating of the preservative on the cell-walls. Obviously, empty-cell treatments result in considerable economy of the preservative.

The most prominent of the full-cell processes are the Burnett, Card, Allardyce, Wellhouse, and Rütgers. Of the empty-cell processes, the Rüping and Lowry are the best known.

**21. Full-cell Treatments.**—Bethell. The best known of all preservative systems is the full-cell Bethell, employing straight creosote as the preservative. In operating the Bethell process, the timber to be treated is loaded upon trucks and run into a cylinder capable of withstanding a high pressure. These cylinders, or retorts, as they are now called, are sometimes as much as nine feet in diameter

## Sec. 9

## WOOD PRESERVATION

and 165 feet long. They are made of boiler plate and are provided with doors which may be hermetically sealed and are tight under a high pressure. For light treatment, the timber may be only air seasoned, but when a heavy treatment is desired the timber is steamed after it is put into the cylinder. The method of operation is as follows:

After the doors are closed, live steam is admitted and a pressure



FIG. 345.—View of pressure treating cylinders.

of about 20 pounds per square inch is maintained for several hours, the exact time depending upon the individual opinion of the operator as well as upon the moisture-content and the size of the timber being treated. In some cases the steam pressure is allowed to go con-

siderably above 20 pounds, but much above this there is constant danger of injuring the timber. When the steam is finally blown out of the cylinder, a vacuum is created and as much of the air as possible is exhausted from the cylinder and from the wood structure. The condensed steam and sap from the wood are drawn off at the same

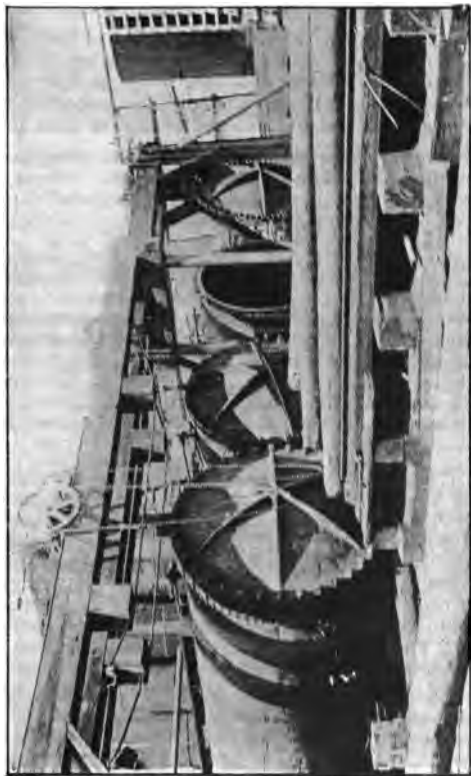

Fig. 346.—Showing one type of door, pressure treating cylinders.

time. The exhaustion period varies with the extent of the treatment. Finally, after a sufficient vacuum is obtained, the creosote oil is run into the cylinder and the pressure pumps are started and continued until the desired amount of preservative fluid has been injected. The remaining oil is then forced back into the storage tanks. The timber is allowed to drip for a few minutes and finally the cylinder



doors are opened and the treated timber withdrawn. The whole cycle of operation takes from six to twenty hours, depending upon the condition and kind of timber, size of treating cylinder, quantity of injection, etc. As a rule, it requires about three and one-half hours for steaming, about one hour for vacuum and whatever time it may be necessary to get the required injection. Figs. 345 and 346, show two views of pressure treating cylinders.

22. **Burnett.** The Burnett process is similar to the Bethell, but, instead of using creosote as the preservative, it employs a two to three per cent solution of zinc chloride, which is injected into the timber under pressure in the same way. The use of zinc chloride, or "Burnettizing," for treating railroad ties dates from 1850.

23. **Wellhouse.** The users of the Wellhouse process claim to have overcome the chief objection to the Burnett system; namely, the solubility of the zinc chloride and the consequent danger of its being dissolved out of the timber when it is put into use. To prevent this the zinc chloride treatment is followed by an injection of glue and tannin, which forms an insoluble "leather" stopping up the wood pores.

24. **Rütgers.** This is another method of preventing the leaching of the zinc chloride. A mixture of zinc chloride and creosote is employed consisting of from fifteen to twenty per cent creosote and a three to four per cent solution of zinc chloride. The emulsion is forced into the timbers, as in the Burnettizing and Bethell processes. This system is extensively used in Europe, and to some extent in this country.

25. **Card.** This process substitutes creosote oil for the glue and tannin of the Wellhouse process, it being claimed that the oil is effective in preventing the zinc chloride from being dissolved out. The chief difference between this process and the Rütgers is that during the time of injecting the liquid into the timber the mixture is kept in continuous circulation by means of a centrifugal pump. It is claimed that this precludes the possibility of a separation of the zinc chloride and creosote, and insures a uniform injection of the preservatives. The following statement is made by the exploiters of the Card system concerning its operation and efficiency:

"In the zinc creosote or mixed treatment, as it is sometimes called, the light oils, such as phenols and cresols, to a certain extent, are soluble in hot water and are carried with the zinc chloride into the heart-wood of the timber as well as through the sap-wood. The heavy oils will not penetrate the heart-wood but are deposited in the sap-wood, and as these heavy oils are insoluble in water they prevent the zinc chloride from leaching out of the timber.

"The two solutions are kept constantly mixed while under pressure by means of a centrifugal pump attached to the treating cylinder; the suction to this pump is connected to the top of the cylinder, in the middle and at each end, and the discharge from the pump enters the bottom of the cylinder, and is distributed the entire length of

the cylinder through a perforated pipe. The mixing device works under the same pressure that is applied to the treating cylinder. The appliance for mixing the emulsion can be applied to any kind of cylinder, and is inexpensive in its first cost, operating and maintenance. Since its installation at the several plants now using the zinc creosote process, the contention by some that the creosote and zinc solution cannot be mixed is proven to be without foundation, as all samples drawn from different parts of the retorts, and at all times during the process of treating, show the oil and solution to be in the exact proportions intended. A water solution of chloride of zinc has greater penetrating powers than creosote oil, and therefore it can easily be injected under pressure throughout the heart-wood of timber."

This description serves well to illustrate the principles underlying the processes employing the zinc chloride and creosote combination. All of them are operated under the theory that the creosote will serve as a plug to hold in the zinc chloride.

**26. Allardyce.** The Allardyce process also employs creosote and zinc chloride, but in this method of treatment the zinc chloride is first injected and then followed by a separate treatment of creosote, amounting to about one to three pounds per cubic foot.

The advocates of this process claim that inasmuch as the creosote oil follows the zinc chloride, a more effective protection is offered against leaching out of the salt, the creosote acting as a plug.

**27. Empty-cell, Treatment. Rüping.** The Rüping process aims to secure protection against decay with a comparatively small quantity of creosote. Only thoroughly air-seasoned timber can be used in this process, because its successful operation depends upon compression of the air in the wood-cells. The preliminary steaming and vacuum as carried out in the Bethell process are therefore omitted.

After the timber has been placed in the cylinder and the doors are closed, it is subjected to an air pressure of about 75 pounds, which compresses the air contained in the cells. Still holding this pressure, the creosote is forced into the cylinder at a higher pressure, and after the timber has been well covered with the preservative, the pressure is increased to about 225 pounds. This increased pressure forces the oil into the wood-cells. Then the pressure is released and the expansive force of the compressed air within the wood forces out a part of the oil and leaves merely a coating of the preservative on the cell-walls. The surplus oil is then run back into the storage tank. The expulsion of the surplus oil may be increased by a vacuum in the treating cylinder.

**28. Lowry.** As in the Rüping process, the timber is seasoned before treatment, but no compressed air is employed in injecting the preservative. As soon as the cylinder is closed, the oil is admitted and forced into the timber by pressure. Then the oil is run out of the cylinder, and a high vacuum is quickly drawn. It is claimed that

the sudden expansion of the air, which has been compressed in the wood-cells, drives out the surplus oil, and that a deep penetration but light treatment is thereby given to the timber.

29. **ATMOSPHERIC PRESSURE PROCESSES.** It is possible by means of some of the modifications of the atmospheric or low-pressure systems to effect full-cell or empty-cell treatment as in the high-pressure systems. Such treatments cannot be given with the same degree of facility or with the same effectiveness as with the high-pressure systems, but in many instances the treatment is adequate.

30. **Full-cell Treatments.—Steeping in Cold Preservative.** The simplest form of non-pressure full-cell treatments, if such a term can be applied to a process usually giving only superficial treatment, is the cold-steeping or soaking process extensively employed in the early days of wood preservation and used to some extent at the present time.

The timber to be treated is placed in an open vat and covered with the cold solution, which may be mercuric chloride, zinc chloride, copper sulphate, or creosote oil, as the case may be. In using mercuric chloride, it is necessary to employ non-metallic steeping pits on account of the corrosive action of the mercury. This treatment has proven very effective in preserving timber, though in this country its use for line timber has been confined almost entirely to the New England States, where some electric companies use kyanized cross-arms. (In the Appendix will be found a report of the German Government's Telegraph Department, wherein very favorable mention is made of the mercuric chloride treatment.)

31. **Hot or Boiling Treatments.** Timber is sometimes treated by simply boiling it in the preservative contained in an open tank or closed retort for varying lengths of time. The preservative most commonly used in this process is a heavy creosote oil. The Forest Service reports that the following method is used on the Pacific coast for Douglas fir, which is an exceedingly difficult wood to treat. The timber, usually green, is placed in a treating cylinder containing creosote heated to a temperature slightly above the boiling point of water. This hot bath is continued for a time varying from several hours to two days or more. The duration of treatment depends upon the size and condition of the timber. During the bath much of the water contained in the sap is driven off together with the volatilized light oils. These vapors are caught in a condenser, the water separated, and the oil then run back into the receiving tank to be used over again. Finally, an oil pressure of from 100 to 125 pounds is applied, and at the same time the temperature of the oil is allowed to fall, thus forcing the preservative into the timber. This practice is subject to the general objection that it is unwise to treat timber before it has had time to dry out in the open air.

It is evident that the efficiency of the process is much enhanced by the final application of pressure, and that simply boiling in an open tank is very unsatisfactory and inefficient.

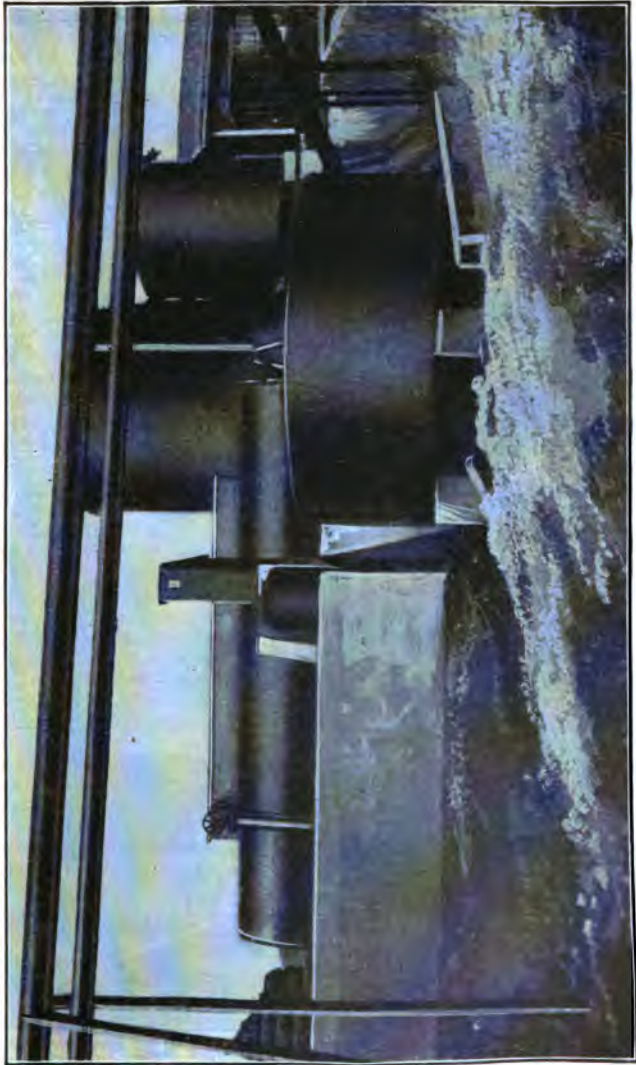

FIG. 347.—Non-pressure plant for the treatment of mine timbers installed and operated by The Philadelphia and Reading Coal and Iron Co. Capacity, 10,000 board feet daily.



FIG. 348.—Butt treatment of poles in open tank.

**32. Alternate Hot and Cold Treatment.** This process is usually carried out in an open tank, and it is the one generally known as the "Open-Tank System." However, in some situations it has been found advisable to employ, in carrying out the process, a low, artificial pressure, which necessitates, of course, a closed tank or retort. The wood is first treated with oil brought to a temperature of from 180 to 220 degrees Fahrenheit, for a sufficient length of time to heat the wood uniformly to the temperature of the preservative. It is then either changed to another bath containing cold preservative or the hot preservative is drawn out and replaced by a charge of cold preservative at or below atmospheric temperature; or the timber may be allowed to remain in the heated oil, heating being stopped and the oil permitted to cool down. The theory underlying the successful operation of any of these modifications is that the preliminary heating expands the air in the wood-cells, and when the cold oil is introduced the sudden contraction creates a partial vacuum which draws in the oil. In some instances, exceedingly good penetration has been obtained by this method, but it is not applicable to all classes of wood, owing to variations in their penetrability.

The simplest equipment for the treatment of poles and cross-arms by the open-tank method consists of a tank, about eight feet deep, set high enough above the ground to permit of a fire beneath it. Facilities should be provided for the convenient handling of the poles. Where steam is available, it may be used to advantage to heat the liquid by means of a coil in the tank, and also to operate a hoisting engine for handling the poles. The liquid may be pumped from the treating tank to make room for the cold oil to be introduced from another tank, or two treating tanks may be employed, one for the hot treatment and one for the cold. In connection with its California experiments, the Forest Service described a pole-treating plant having a capacity of 120 poles per day, which was estimated to cost between four and five thousand dollars; or a plant with a capacity of fifty poles per day, estimated to cost two thousand dollars. The latter equipment was to consist of one 12,000-gallon iron storage tank, two 5 ft.  $\times$  5 ft.  $\times$  8 ft. treating tanks, one 60-ft. mast with 16-ft. boom derrick, a small hoisting engine, a 20-hp. boiler, steam coils for heating the treating tank, and one steam oil pump, capacity 2,000 gallons per hour.

Fig. 347 shows a view of the treating plant of the Philadelphia and Reading Coal and Iron Co., where a closed retort is used for treating mine timber, but which could be utilized for treating poles and cross-arms. In this arrangement, the timber is run into a cylinder on small buggies, and the doors are then closed and sealed as in the high-pressure system. Steam coils heat the preservative to 220 degrees Fahrenheit. After the hot bath, which is continued according to the condition and size of the wood, the hot preservative is drawn off to the lower tank. Cold oil or zinc chloride is then introduced into the treating cylinder from the storage tank. A small pump is used to pump the oil back to the storage tank and sometimes this pump is employed to produce a low pressure in the

treating cylinder. Fig. 348 shows a view of a simple open-tank outfit for treating poles; and Fig. 349 gives an extremely simple form of experimental open tank.



FIG. 349.—A very simple form of experimental open tank.

The most interesting and useful data found, regarding open-tank treatments have been obtained from the reports of the Forest Service in connection with its California experiments with western yellow pine and western red cedar. (Part III.)

**33. Empty-cell Treatment.—Open Tank.** In the full-cell treatment with creosote oil, the timber is removed from the tank with a considerable amount of oil on its surface. This is objectionable, not only on account of the waste of oil, but also because of the subsequent dripping of the oil from the poles and cross-arms after they have been installed. This difficulty is said to be overcome by taking a third step in the open-tank treatment before described. Before removing the timber, after the cold bath, it is reheated to 200 degrees Fahrenheit, for a period of from two to three hours. The same result



Fig. 350.—Untreated cedar pole decayed at ground line and upward about two feet.

may be accomplished by taking the timber out of the bath in the second stage of the process, after the creosote has cooled down through a range of 20 degrees Fahrenheit. This causes the contracting air in the wood to draw in the free oil from the surface. This method gives about the same penetration as the full-cell open-tank process, but saves a considerable quantity of oil, and, moreover, leaves the surface of the wood dry.

**34. LOW ARTIFICIAL PRESSURE SYSTEMS.—Full- or Empty-cell Treatments.** The Forest Service has recently endeavored to com-



## Sec. 9

## WOOD PRESERVATION

bine the advantages of both the pressure and non-pressure processes in a low-pressure system. The seasoned timber is first treated in a hot bath, as in the non-pressure treatment, then it is subjected to a cold bath; but, instead of depending entirely upon the atmospheric pressure to force the preservative into the wood, some artificial pressure is also applied. The low-pressure process cannot, of course, be used with an open tank, and requires, preferably, a closed cylinder, as in high-pressure work. The advantage claimed



FIG. 351.—Untreated chestnut pole showing falling off of sap-wood.

for this method is that it requires much less time for treatment than in the open tank, and a greater absorption, and a deeper and more uniform penetration are secured.

**35. MISCELLANEOUS TREATMENTS.—Brush Treatments.** Applying the preservative by means of a brush is the most common, but the least efficient, of all treatments. For good results it is essential that the timber be thoroughly seasoned, and that the wood be dry at the time of treatment. The preservative is usually kept heated to about 200 degrees Fahrenheit and is applied to the wood with a suitable brush. Care should be taken to fill all checks, knot-holes,

and abrasions. A second coat should be applied after an interval of not less than twenty-four hours. Besides treating the butt of the pole, the roof of the pole and cross-arm gains should not be overlooked, as such cuts, if left unprotected, expose the interior to decay. Some companies report that they apply the preservative with a spraying machine, claiming it has decided advantages over the brush method in that it requires less labor and better fills all cracks.



FIG. 352.—Cedar pole coated with tar. Four year service all sap-wood decayed to the ground.

Figs. 350 and 351 illustrate how the sap-wood may scale from poles, leaving the untreated interior exposed to decay. Such scaling, or mechanical injury from various causes, even the spur holes made by linemen's climbing irons, will defeat the object of brush treatments. Fig. 352 shows a cedar pole after four years' service, which had been treated with tar. All of the sap-wood is decayed to the ground line and is loose to a height of three-and-a-half feet. Paint-

ing or coating poles with tar is not so generally practiced now on account of the increasing appreciation of its uselessness, though a few years ago it was a very common practice. In contrast to the untreated chestnut pole shown in Fig. 353, the condition of the pole shown in Fig. 354 should be noted. This is a pressure-creosoted pine pole which has been in service near Norfolk, Va., for eighteen years, and there is no sign of decay. Fig. 355 shows a cross section of a well-treated creosoted pine pole.



FIG. 353.—Untreated chestnut pole decayed at ground line.

**36. Brush Combined with Open Tank.** A combination of open-tank and brush treatments is made by first treating the timber with zinc chloride in an open tank, then giving it one or more brush applications of creosote or heavy tar oil.

**37. Jacket or Butt Settings.** Poles are sometimes set in shells of concrete. It is questionable whether this preserves the pole other than in a mechanical way by giving greater stability. When the

concrete hardens, it contracts and may leave a space around the pole, where moisture may collect and cause the wood to decay. Some operators surround the pole with a heavy band of pitch or tar. This is not as desirable as the concrete, because it does not add to the mechanical strength of the pole setting, and has been known to create rather than to prevent decay.

Mention may be made here of a patented process making use of a jacket of asbestos and asphaltum placed around and at one or two



FIG. 354.—Pressure creosoted pine pole—18 years' service under southern climatic conditions. No decay to date.

inches from the pole near the ground line. The jacket has a cement bottom and is filled with a mixture of hydrated lime, chloride of sodium, copper sulphate and sand. Over the top of the jacket and surrounding the pole a reinforced cement cap is placed. It is claimed that the chemicals are held in a tight compartment, from which they are slowly dissolved and drawn into the pole.

Such descriptions might be continued indefinitely until the simplest

## Sec. 9

## WOOD PRESERVATION

form of pole preservation or butt reinforcement were reached, such as the method employed by a large telephone company, which may be described as follows: When the pole butts are found to be in a fairly advanced stage of decay, a stub, having about the same dimensions as the pole butt, is placed in the ground alongside of the

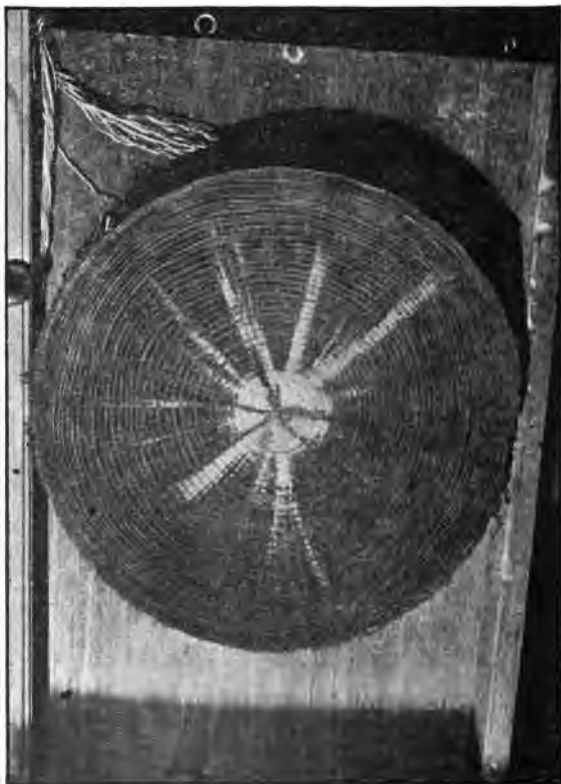

FIG. 355.

pole. This stub is long enough to extend from the bottom end of the pole to a point about two feet above the ground line. It is secured to the pole butt and to the pole above the ground either by wrappings of heavy wire or by through bolts, or a more stable job may be made by combined wrapping and bolting. This plan could

scarcely be carried out under city or town conditions, as the unsightliness of the stub would be a serious objection, but it might be followed successfully on trunk lines which pass through sparsely settled territory. There seems no reason why the upper part of poles, particularly of the harder species of wood, should not be used indefinitely, provided always that the butt reinforcement is made as strong and reliable as would be the continuous pole.

1

1

1

1

1

1

1

1

## **SECTION 9**

### **PRESERVATIVE TREATMENT OF POLES AND CROSS-ARMS**

---

#### **PART II RECOMMENDED PRACTICE AND SPECIFICATIONS**





**SECTION 9**  
**PRESERVATIVE TREATMENT OF POLES**  
**AND CROSS-ARMS**

**PART II—RECOMMENDED PRACTICE AND**  
**SPECIFICATIONS**

**TABLE OF CONTENTS**

	ARTICLE
<b>General</b> .....	1
<b>Preservatives</b>	
General.....	2
Choice of Preservatives.....	3
Specifications.....	4
A—Specifications for Coal-Tar Creosote.....	5
B—Specifications for Mixed Oils.....	6
C—Specifications for Water-Gas Tar Creosote.....	7
Auxiliary Specifications.....	8
Specifications Covering Oil for Brush Treatments.....	9
<b>Treatments</b>	
General.....	10
Pressure System.....	11
Creosoted Pine Poles.....	12
Creosoting of Poles.....	13
Creosoted Pine Cross-arms.....	14
Creosoting of Pine Cross-arms.....	15
Open Tank System.....	16
Open Tank Treatment of Pole Butts.....	17
<b>Description of Open Tank Plants</b> .....	18
<b>Brush Treatments</b> .....	19

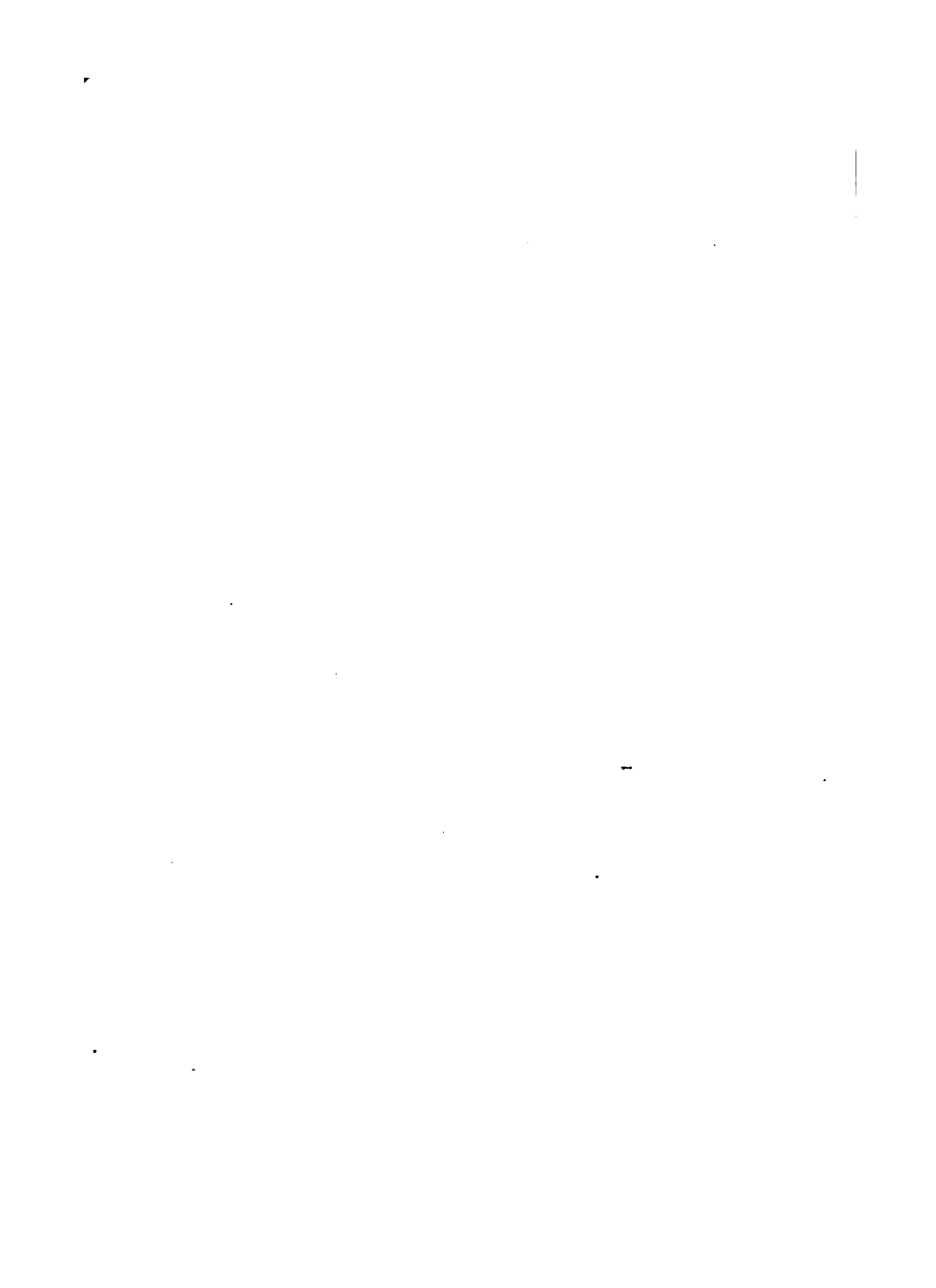

## **SPECIFICATIONS FOR PRESERVATIVES AND METHODS OF TREATMENT**

**1. GENERAL.** The following data have been compiled from the 1911 report of the committee on the preservative treatment of poles and cross-arms, and contain only the recommended specifications for preservatives, preservative methods and apparatus.

### **PRESERVATIVES**

**2. General.** The subject matter contained in Part I, while serving well the purpose of describing the nature of preservatives commonly employed in protecting timber from decay and the most common methods of examination, contains little in the way of definite recommendations but is included in order to present to the members of the Association, few of whom have any knowledge of the subject, information of a more or less general nature emanating from recognized authorities, without attempting to reconcile conflicting views or do more than weed out the obviously bad from the obviously good, so that the final recommendations as contained herein would meet the special needs of the National Electric Light Association.

Having the foregoing in mind, radical departures from established methods were found necessary, but the recommendations have been prepared having as their object, to which all else was secondary, the following:

a. The choice of the best preservative for the protection of poles and cross-arms obtainable at a cost commensurate with its service.

b. Specifications which, while fully covering the requirements of a high-grade preservative, would at the same time be fair to the manufacturer and provide a material no more expensive than the best grades now on the market.

c. A method of analysis which would insure compliance with the specifications.

**3. Choice of Preservatives.** Coal-tar creosote being well-known as a timber preservative, and its value as such being established beyond question, is on this account recommended by the committee as the standard preservative.

Under certain circumstances it has been found advisable to use mixtures of coal-tar creosote and various other tar products. The circumstances under which the use of such mixtures are warranted will depend, to a large extent, upon the cost of the various oils and tar products and the conditions under which they are to be used. The admixture of certain tars to coal-tar creosote has been found particularly advisable where the latter is of low gravity, and also where a cheaper preservative could be obtained by using such a mixture than by the use of straight coal-tar creosote. Water-gas

tar and products obtained by the distillation of water-gas tar have been used for some years, but records of service of timbers treated with these substances are either not of sufficient duration or of sufficient authenticity to warrant definite conclusions to be drawn as to their value. In view of the fact, however, that considerable quantities of water-gas tar and distillates are available for use as timber preservatives and are being offered commercially, the committee has drawn up specifications covering these latter materials, as well as for coal-tar creosote and for mixed oils. (See Specifications A, B and C.)

4. **Specifications.** Existing specifications for the purchase of creosote oil, which are in general use, do not fully meet the present requirements, since it is possible, even under the most stringent of them, for unscrupulous manufacturers to adulterate and sell as pure distilled creosote mixtures with other materials. Since such adulterations are usually made to cheapen the cost of the oil, it renders mutually honest competition impossible and defrauds the purchaser who is entitled to receive what he has ordered and for which he has paid.

It is not intended to imply that it is impossible to obtain a pure creosote, and often so-called adulterated oils are knowingly purchased and used with the consent of the purchaser of the treated timber, but it is a well-known fact that the protection offered by strict specifications and a method of analysis which will enforce them is at times needed, and, therefore, the specifications drawn up which, while offering no hardship to the honest producer, will insure the receipt of an oil such as was desired by the purchaser.

The specifications, which are offered as covering three kinds of creosoting material, have followed, as closely as was deemed advisable by the committee, the well-known specifications known as the "American Railway Engineering and Maintenance-of-Way Specifications," the chief difference being the addition of certain tests which would more certainly tend to indicate adulteration, and the adoption of a flask instead of the retort for making the distillation test. The chief reason for this radical step is that it was the general opinion that it would be much easier to enforce the specifications when a flask was used than when using the retort, for the reason that retorts of a uniform size and shape are difficult to obtain, and a slight change in the position of the thermometer, which is placed in reference to the surface of the oil, would give widely different results, and also on account of the difficulty experienced in placing the thermometer exactly one-half inch above the surface of the oil.

It is generally admitted by chemists that the retort is an antiquated piece of apparatus, and that it would be best to adopt the most scientific methods available. It has been urged by some, who favored the adoption of the retort method of distillation and the maintenance-of-way specifications in their entirety, that any change in method would introduce confusion in the creosoting industry.

This argument is not tenable, provided a proper relation is established between the results obtained by the two methods of distillation. The results obtained by the flask method of distillation herein recommended are practically the same as those obtained by the retorted method of distillation.

Three specifications for creosote are offered: Specification "A" is designed to insure the furnishing of a high grade of coal-tar creosote. Any oil conforming to this specification will include all the qualities that would ordinarily be required in preservative work, and the conditions of the specification enable the manufacturers or agents to make such an oil a commodity as easily available to the purchaser or user as are other grades of creosote. For these reasons such an oil as the standard preservative has been adopted.

Where circumstances warrant the admixture of certain tars to coal-tar creosote, Specification "B" is suggested. (See text accompanying specification for explanation of conditions under which the use of such a preservative might be warranted.)

Where water-gas tar creosote is used, Specification "C" is suggested. (See text accompanying specification for further remarks concerning this preservative.)

## 5. "A" SPECIFICATIONS COVERING COAL-TAR CREOSOTE OIL AND METHODS OF ANALYSIS

### SECTION 1—SPECIFICATION

**DEFINITION.** The material required under these specifications is that commonly known as dead oil of coal tar or coal-tar creosote. More specifically defined it is:

(a) A distillate from the tar produced as a by-product in the manufacture of coal gas from bituminous coal by the retort method,  
or

(b) A distillate from the tar produced as a by-product in the manufacture of coke from bituminous coal by the by-product coke-oven process,  
or

(c) A distillate obtained from a mixture of the above mentioned tars,  
or

(d) A product obtained by mixing distillates from the above mentioned tars.

It is understood that the presence of any hydrocarbons other than the above, either in the original tars or in the distillates therefrom, will, by defeating the purpose of this specification, which is to secure a pure distilled oil from coal gas or coke-oven tar, be looked upon as an adulteration, which may result in the rejection of the oil. As further defining the material required, the hydrocarbons specifically provided against include the following:

(e) Raw or partly distilled tars or petroleum oils of any description whatsoever, such as coal tar, coke-oven tar, water-gas tar, oil tar,

## Sec. 9

## WOOD PRESERVATION

lignite tar, blast-furnace tar, producer tar, wood tar, and crude petroleum.

(f) Distillates from any of the above mentioned tars or oils, except distillates from coal tar and coke-oven tar

(g) Residues from any of the above mentioned tars or oils.

(h) Products obtained by filtration of any of the above mentioned tars or oils

The purchaser of the treated timber, or his representative, shall have the right to take samples of the oil from the oil tanks or from the treating cylinders at the treating plant and to test such samples whenever or wherever desired. The oil may be refused upon satisfactory evidence that it does not conform to the specifications.

In the event of a dispute between the purchaser of the treated timber and the firm treating the same, the matter shall be referred to a referee mutually agreed upon by a representative of the purchaser and the manufacturer, and the decision of the referee shall be binding and final.

Information, as complete as possible, shall be furnished to the purchaser upon request as to the origin and history of the oil.

The oil required under these specifications must, in addition to being of satisfactory origin, possess certain physical and chemical characteristics, and in order to insure that the sample, which is used in determining these characteristics, correctly represents the bulk of the material from which it is taken, the following rules for taking samples must be observed:

**SAMPLING.** A one-gallon sample of the oil shall be taken for analysis, the manner of collecting the same depending upon the nature of storage. The oil must be completely liquid when the sample is taken, and it may therefore be necessary to heat the tank or other receptacle in which it is contained. The following general rules shall be observed when sampling from:

(a) **Tank Boat.** The sample shall be taken from the pumping system while discharging from the boat into the receiving tank as follows: A half-inch cock shall be placed in the line at any convenient point and a continuous stream of oil drawn through this cock during the entire time of emptying the boat. The rate of flow of the stream should be proportionate to the rate of flow of the oil in the pumping line and it should be such that a gallon sample may be collected from each 10,000 gallons of oil passing through the pipe. The bulk sample thus obtained, which may be caught in a barrel or other suitable receptacle provided for the purpose, shall be thoroughly mixed and shall, if necessary, be heated to bring into solution any material which may have crystallized out. A one-gallon sample shall be taken from this for analysis.

(b) **Storage Tanks less than Twenty Feet in Depth.** In sampling from storage tanks of less than twenty feet in depth, a "thief" shall be employed. It shall be made of a length of one-half inch pipe and provided at the lower end with a lever handle cock having an opening of approximately the same size as the interior of the pipe. This cock being open, the "thief" is lowered slowly into the tank and

when it has touched bottom, the cock is closed by means of a chain, wire, or iron rod carried to the top of the pipe. A sufficient number of samples thus procured shall be taken to aggregate one gallon.

(c) **Storage Tanks over Twenty Feet in Depth.** Samples shall be taken from such tanks through one-half inch cocks placed one above the other and one foot apart on the side of the tank. One gallon of oil shall be withdrawn from each level, and the bulk sample thus obtained shall be thoroughly mixed as in (a) and the final sample taken from this.

(d) **Tank Cars.** Drip samples shall be taken from tank cars as in (a).

(e) **Treating Cylinders.** Samples from treating cylinders shall be taken from the charging and discharging line as in (a).

**PHYSICAL AND CHEMICAL CHARACTERISTICS.** The oil under these specifications must have the following characteristics:

1. It shall have a specific gravity of at least one and three-hundredths (1.03) and not more than one and eight-hundredths (1.08) at thirty-eight degrees Centigrade (38° C.). If the gravity is taken at a higher temperature, a correction of eight ten-thousandths (.0008) for each degree Centigrade above thirty-eight (38) shall be made.

2. There shall be not over one per cent (1%) of residue insoluble in hot benzol.

3. The original oil shall contain not over two per cent (2%) of water.

4. The oil shall be miscible in absolute alcohol, volume for volume.

5. The residue remaining upon sulphonating a portion of the total distillate shall not exceed one per cent (1%).

6. The oil shall contain not more than eight per cent (8%) of tar acids.

7. When two hundred (200) grams of the oil are distilled in accordance with the requirements of the specifications for the analysis of coal-tar dead oil or coal-tar creosote hereinafter referred to and results calculated to water-free oil:

(a) Not more than five per cent (5%) of oil shall distill off up to two hundred and five degrees Centigrade (205° C.).

(b) Not more than thirty-five per cent (35%) of oil shall distill off up to two hundred and thirty-five degrees Centigrade (235° C.).

(c) Not more than eighty per cent (80%) shall distill off up to three hundred and fifteen degrees Centigrade (315° C.).

(d) The coke residue shall not exceed two per cent (2%).

(e) The distillate between two hundred and five (205) degrees Centigrade and two hundred and thirty-five (235) degrees Centigrade shall deposit naphthalene on cooling to fifteen (15) degrees Centigrade.

---

**NOTE.**—The percentage distilling to two hundred and forty-five (245) and two hundred and seventy (270) degrees Centigrade shall be noted.



## SECTION 2.—ANALYSIS SPECIFICATIONS.

**GENERAL.** The apparatus employed in making the distillation and other tests required under these specifications shall conform in general to that shown on drawings No. 1 (Fig. 356) and No. 2 (Fig. 357) attached to and forming a part of these specifications, except that a five per cent (5%) variation from the dimensions given is allowed. The distilling apparatus must be assembled as in drawing No. 3 (Fig. 358). As further defining the requirements in this respect, the following description of certain parts and manner of assembling is given:

(a) **Flask.** The flask required is a Lunge side neck distilling flask, provided with a trap (drawing No. 1) (Fig. 356), and having a tubular thirty centimeters (30 cm.) long placed close to the bulb. The flask must have a capacity of three hundred cubic centimeters (300 c.c.) when filled to a height equal to its maximum horizontal diameter.

(b) **Thermometer.** The thermometer must be made of Jena glass and be nitrogen filled and graduated at intervals of one millimeter (1 mm.) in single degrees Centigrade, the scale reading to plus four hundred degrees Centigrade (+400° C.).

(c) **Receivers.** The glass receivers may be of any convenient size and shape; the flask shown on drawing No. 2 (Fig. 357) is, however, recommended.

(d) **Shield.** A shield ten centimeters (10 cm.) in diameter and eight centimeters (8 cm.) high, made of asbestos must be provided (drawing No. 2) (Fig. 357).

(e) **Support for Flask.** The flask must rest on an asbestos board one-half centimeter (.5 cm.) in thickness by fifteen centimeters (15 cm.) in diameter, a hole five centimeters (5 cm.) in diameter being cut in the center of the board. The board shall rest on a ring stand (drawing No. 2) (Fig. 357).

**ASSEMBLING APPARATUS.** The apparatus must be assembled as shown on drawing No. 3 (Fig. 358). The thermometer passes through a cork in the top of the flask and is so placed that the top of the bulb of the thermometer is on a line with the bottom of the tubular outlet. The asbestos shield is placed around the bulb of the flask and the flask mounted on the asbestos board supported on the ring stand as shown on drawing No. 3 (Fig. 358).

**DISTILLATION TEST.** Two hundred grams of the oil shall be used in the analysis, this amount being weighed on a balance sensitive to one milligram (1 mg.), in the following manner:

The flask is first placed on the pan of the balance and weighed, and the weight recorded. Without removing the flask, a two hundred (200) gram weight is placed on the opposite pan of the balance and a sufficient quantity of the oil dropped into the flask through a long stem funnel to bring the pans into equilibrium. The flask is then removed from the balance and set up as in drawing No. 3 (Fig. 358). Care must be taken that the cork stopper carrying the thermometer fits tightly into place. The flask should be heated, preferably by a Bunsen or other standard form of gas burner. The

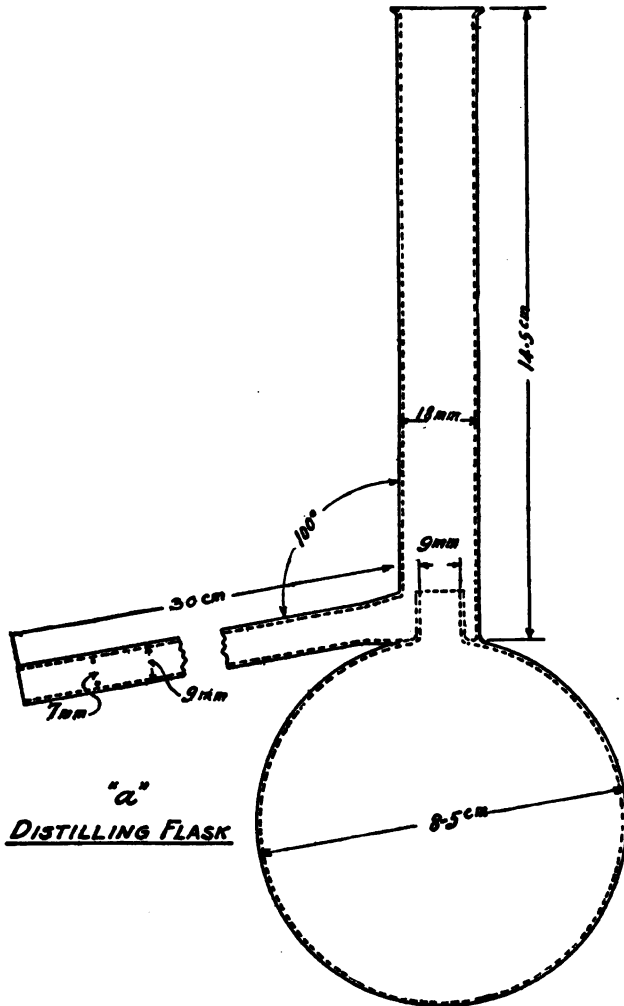

FIG. 356.—National Electric Light Association creosote oil analysis.

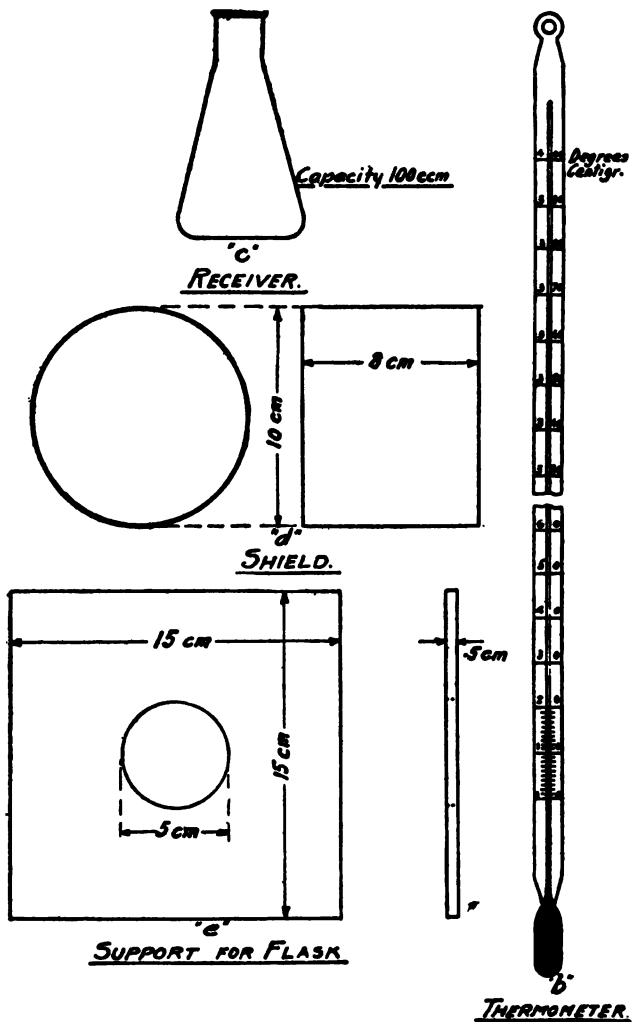

FIG. 357.—National Electric Light Association creosote oil analysis.

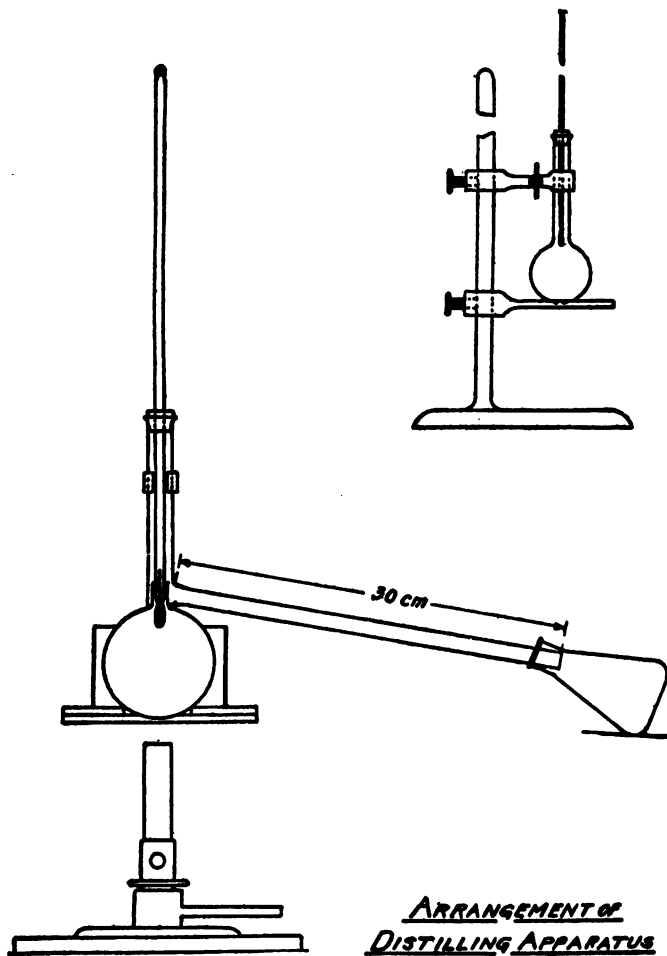

FIG. 358—National Electric Light Association creosote oil analysis.

distillation shall be continuous and at such a rate that two (2) drops of oil per second (5 c.c. per minute) leaves the end of the tubular after the thermometer registers two hundred and five degrees Centigrade (205° C.), or after all of the water has been driven off. The percentage weights of the following fractions shall be recorded:

- To 205 degrees Centigrade.
- To 235 degrees Centigrade.
- To 245 degrees Centigrade.
- To 270 degrees Centigrade.
- To 315 degrees Centigrade.
- To 360 degrees Centigrade.

## 6. "B" SPECIFICATIONS COVERING MIXED OILS AND METHODS OF ANALYSIS.

### SECTION 1.—SPECIFICATION

**DEFINITION.** The material required under these specifications is a homogeneous mixture of a distilled product obtained from coal gas tar or coke oven tar and generally known as coal-tar dead oil or coal-tar creosote with certain other hydrocarbons. More specifically defined, the added material, which must constitute not more than forty (40) per cent of the final mixture, may consist of:

- (a) Raw or partly distilled coal-tar, coke-oven tar, water-gas tar, lignite tar, blast-furnace tar, and producer tar,
- or
- (b) Distillates from any of the above mentioned tars,
- or
- (c) Products obtained by filtration of any of the above mentioned tars.

As further defining the material required, it is understood that the presence in the oil of any of the hydrocarbons given below will, by defeating the purpose of this specification, which is to secure a mixed oil containing certain hydrocarbons, be looked upon as an adulteration and the oil may be rejected. The hydrocarbons provided against are as follows:

- (d) Petroleum oil or distillates or of residues therefrom.
- (e) Water gas tar containing over ten per cent (10%) paraffin oil.
- (f) Oil tar containing over ten per cent (10%) paraffin oil.
- (g) Distillates or residues from water gas tar or oil tar containing over ten per cent (10%) paraffin oil.

**CONDITIONS OF PURCHASE.** Same as in specifications covering coal-tar creosote oil.

**SAMPLING.** Same as in specifications covering coal tar creosote oil.

**PHYSICAL AND CHEMICAL CHARACTERISTICS.** The oil required under these specifications must have the following characteristics:

1. It shall have a specific gravity of at least one and four-hun-

dredths (1.04) and not more than one and ten-hundredths at thirty-eight degrees Centigrade (38° C.).

2. There shall be not over three per cent (3%) of residue insoluble in hot benzol.

3. The oil shall contain not over three per cent (3%) of water.

4. The residue remaining upon sulphoning a portion of the total distillate shall not exceed five per cent (5%).

5. The oil shall contain not less than two per cent (2%) nor more than eight per cent (8%) of tar acids.

6. When two hundred (200) grams of the oil are distilled in accordance with the requirements of the specifications for the analysis of mixed creosoting oil hereinafter referred to and results calculated to water free oil:

(a) Not more than three per cent (3%) of oil shall distil off up to two hundred and five degrees Centigrade (205° C.).

(b) Not more than twenty-five per cent (25%) of oil shall distil off up to two hundred and thirty-five degrees Centigrade (235° C.).

(c) Not more than eighty per cent (80%) shall distil off to three hundred and fifteen degrees Centigrade (315° C.).

(d) The residue above three hundred and sixty degrees Centigrade (360° C.) shall not exceed thirty-five per cent (35%).\*

#### SECTION 2.—ANALYSIS SPECIFICATION

Same as in Specifications Covering Coal-tar Creosote Oil

### 7. "C" SPECIFICATIONS COVERING WATER-GAS TAR CREOSOTE OIL AND METHOD OF ANALYSIS.

#### SECTION 1.—SPECIFICATION

**DEFINITION.** The material required under these specifications is that known as dead oil of water-gas tar or water-gas tar creosote. More specifically defined, it is:

(a) A distillate from the tar produced as a by-product in the manufacture of carburetted water gas from petroleum oil.

It is understood that the presence of any other hydro-carbons, either in the original tar or the distillate therefrom, will, by defeating the purpose of this specification, which is to secure a pure distilled oil from water-gas tar, be looked upon as an adulteration, which may result in the rejection of the oil. As further defining the material required, the hydrocarbons specifically provided against, include:

(b) Raw or partly distilled tar or petroleum oil of any description, whatsoever, such as coal tar, coke oven tar, water gas tar, oil tar, lignite tar, wood tar, and crude petroleum.

---

\*NOTE.—The percentage distilling to two hundred and forty-five (245), two hundred and seventy (270) and three hundred and sixty (360) degrees Centigrade shall be noted.

## Sec. 9

## WOOD PRESERVATION

(c) **Distillates** from any of the above mentioned tars or oils, except distillates from water gas tars.

(d) **Residues** from any of the above mentioned tars or oils.

(e) **Products** obtained by filtration of any of the above mentioned tars or oils.

**CONDITIONS OF PURCHASE.** Same as in specifications covering coal tar creosote oil.

**SAMPLING.** Same as in specifications covering coal tar creosote oil.

**PHYSICAL AND CHEMICAL CHARACTERISTICS.** The oil required under these specifications must have the following characteristics:

1. It shall have a specific gravity of at least one and three-hundredths (1.03) and not more than one and eight-hundredths (1.08) at thirty-eight degrees Centigrade (38° C.).

2. There shall be not over one per cent (1%) of residue insoluble in hot benzol.

3. The oil shall contain not over two per cent (2%) of water.

4. The residue remaining upon sulphonating a portion of the total distillate shall not exceed five per cent (5%).

5. When two hundred (200) grams of the oil are distilled in accordance with the requirements of the specifications for the analysis of water gas tar dead oil or water-gas tar creosote hereinafter referred to and results calculated to water free oil:

(a) Not more than two per cent (2%) of oil shall distil off up to two hundred and five degrees Centigrade (205° C.).

(b) Not more than ten per cent (10%) of oil shall distil off up to two hundred and thirty-five degrees Centigrade (235° C.).

(c) Not more than sixty per cent (60%) shall distil off up to three hundred and fifteen degrees Centigrade (315° C.).\*

(d) The coke residue shall not exceed two per cent (2%).

### SECTION 2.—ANALYSIS SPECIFICATIONS

Same as in Specifications Covering Coal Tar Creosote Oil

### 8. AUXILIARY SPECIFICATIONS.

Methods of making free carbon determination, sulphonation test, test for tar acids, and test for coke, as referred to in Specifications "A," "B" and "C."

#### DETERMINATION OF FREE CARBON.

The apparatus required is as follows:

Knorr Condenser.

Knorr Flask.

C. S. & S. No. 575 Filter Papers, 15 cm. diameter.

Wire for supporting filter papers.

Ten grams of the oil should be weighed into a small beaker and digested with C. P. toluol on a steam bath. A cylindrical filter cup is prepared by folding two of the papers around a rod about five-

\* **NOTE.**—The percentage distilling to two hundred and forty-five (245) and two hundred and seventy (270) degrees Centigrade shall be noted.

eighths of an inch ( $\frac{3}{8}$ ") in diameter. The inner paper should be cut to fourteen centimeters (14 cm.) diameter. Prior to using the filter papers, they should have been extracted with benzol to render them fat free. The filter cup is dried at one hundred (100) to one hundred and ten (110) degrees Centigrade and weighed in a weighing bottle.

The contents of the beaker are now decanted through the filter cup, and the beaker washed with hot toluol, passing all washings through the cup. The filtrate should be passed through the filter a second time, the residue washed two or three times with hot C. P. benzol and transferred to the extraction apparatus, in which C. P. benzol is used as the solvent, which solvent is vaporized by means of a steam or water bath. The extraction is continued until the filtrate is colorless. The filter cup is then removed, dried and weighed in the weighing bottle. C. P. benzol followed by chloroform may be used instead of C. P. toluol followed by C. P. benzol.

**Precautions.** In removing filter paper from the extraction apparatus see that no particles of mercury find their way into the precipitate. To prevent splashing, the filter paper should be elevated as near to the outlet of the condenser as possible. A good precaution is to cover the top of the filter cup with a round cap of filter paper.

**SULPHONATION TEST.** Ten cubic centimeters (10 c.c.) of the total distillate to three hundred and fifteen degrees Centigrade (315° C.) are placed in a flask and warmed with four (4) to five (5) volumes of concentrated sulphuric acid to sixty degrees Centigrade (60° C.) and the whole transferred to a graduated separatory funnel. (The one shown on drawing No. 4 (Fig. 359) is recommended. The flask is rinsed three times with small quantities of concentrated sulphuric acid and the rinsings added to the contents of the funnel, which is then stoppered and shaken, cautiously at first, afterwards vigorously, for at least fifteen (15) minutes and allowed to stand over night. The acid is then carefully drawn down into the graduated portion of the funnel to within two cubic centimeters (2 c.c.) of where the un sulphonated residue shows. If no un sulphonated residue is visible the acid should be drawn down to two cubic centimeters (2 c.c.). In either case the test should be carried further as follows: Add about twenty cubic centimeters (20 c.c.) of water and allow to stand for one-half hour. Then draw off the water as close as possible without drawing off any supernatant oil or emulsion, add ten cubic centimeters (10 c.c.) of strong sulphuric acid and allow to stand for from fifteen to twenty (15-20) minutes. Any un sulphonated residue will now separate out clear and give a distinct reading. If under two-tenths of a cubic centimeter (.2 c.c.) it should be drawn down into the narrow part of the funnel to just above the stop-cock, where it can be estimated to one one-hundredth of a cubic centimeter (.01 c.c.). The volume of residue thus obtained is calculated to the original oil.

**DETERMINATION OF TAR ACIDS.** One hundred cubic centimeters (100 c.c.) of the total distillate to three hundred and fifteen



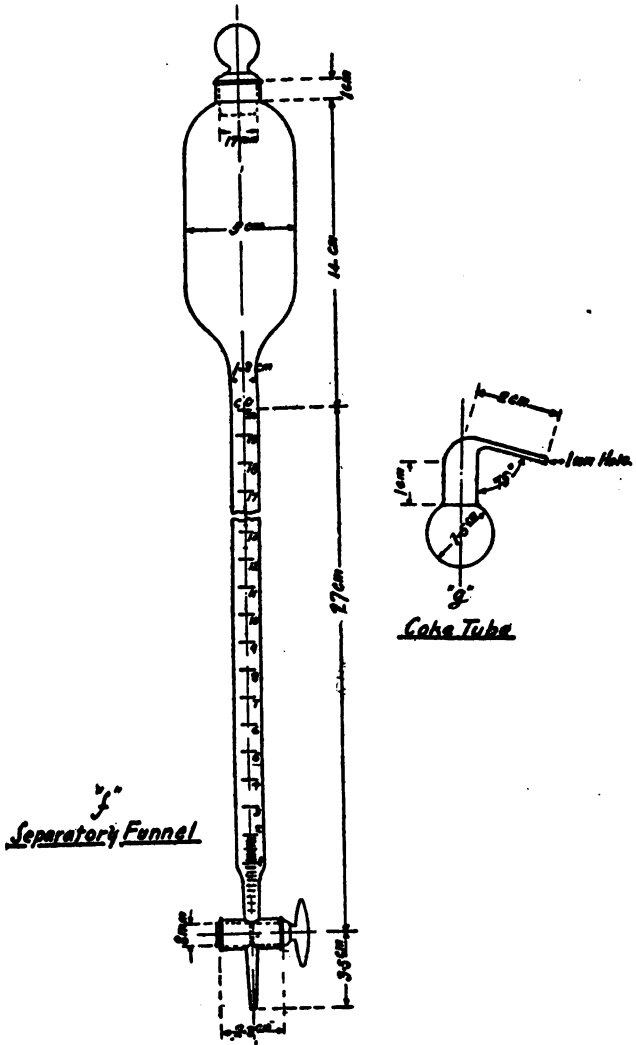

FIG. 359.—National Electric Light Association creosote oil analysis.

degrees (315° C.), to which forty cubic centimeters (40 c.c.) of a solution of sodium hydroxide having a specific gravity of one and fifteen hundredths (1.15) is added, is warmed slightly and placed in a separatory funnel. The mixture is vigorously shaken, allowed to stand until the oil and soda solutions separate and the soda solution containing most of the tar acids drawn off. A second and third extraction is then made in the same manner, using thirty (30) and twenty (20) cubic centimeters of the soda solution, respectively. The three alkaline extracts are united in a two hundred cubic centimeter (200 c.c.) graduated cylinder and acidified with dilute sulphuric acid. The mixture is then allowed to cool and the volume of tar acids noted. The results shown should be calculated to the original oil.

**COKE TEST.** In making the coke determination, hard glass bulbs similar to the one shown in drawing No. 4 (Fig. 359) are to be used. The test is to be carried out as follows:

Warm the bulb slightly to drive off all moisture, cool in a desiccator and weigh. Again heat the bulb by placing it momentarily in an open Bunsen flame and place the tubular underneath the surface of the oil to be tested and allow the bulb to cool until sufficient oil is sucked in to fill the bulb about two-thirds full. Any globules of oil sticking to the inside of the tubular should be drawn into the bulb by shaking or expelled by slightly heating it, and the outer surface should be carefully wiped off and the bulb re-weighed. This procedure will give about one gram of oil. Cut a strip of thin asbestos paper about one-quarter inch wide and about one inch long, place it around the neck of the bulb and catch the two free ends close up to the neck with a pair of crucible tongs. The oil should then be distilled off as in making an ordinary oil distillation, starting with a very low flame and conducting the distillation as fast as can be maintained without spurting. When oil ceases to come over, the heat should be increased until the highest temperature of the Bunsen flame is attained, the whole bulb being heated red hot until evolution of gas ceases and any carbon sticking to the outside of the tubular is completely burned off. The bulb should then be cooled in a desiccator and weighed and the percentage of coke residue calculated to water free oil.

## 9. SPECIFICATION COVERING OIL FOR BRUSH TREATMENTS.

The material required under these specifications is the same as that called for under specification "A," except that it shall have a gravity of between one and eight-hundredths (1.08) and one and twelve hundredths (1.12) at fifteen degrees Centigrade (15° C.), No oil to distil to two hundred and five degrees Centigrade (205° C.), and not more than ten per cent (10%) to two hundred and thirty-five degrees Centigrade (235° C.). Not more than one-half of one per cent ( $\frac{1}{2}\%$ ) of insoluble matter shall be left upon extraction with hot benzol.

## TREATMENTS.

**10. General.** The following recommended methods are particularly adaptable for the local treatment of line timber with creosote. They include standard specifications and descriptions of the actual working plants that would be required by a company in the event of the treating operation being carried out by the company's own employees.

The following methods have been given consideration:

1. Bethel or high-pressure system
2. Open-tank or atmospheric pressure system
3. Brush treatments

**11. Pressure System.** The efficiency of the straight creosote, pressure process, cannot be questioned. Still it should be understood, that owing to the heavy cost of installing such a system, it would come within the province of comparatively few operating companies to own an outfit of this kind. At the same time, as the number of creosoting companies increases, a considerable quantity of treated line timber will be purchased, and it is for the purpose of assisting the buyer in obtaining the best, and therefore the most economical timber for the money expended, that the following specifications are offered.

**12. CREOSOTED PINE POLES.**

**Creosoting.** Unless otherwise ordered, all poles shall be impregnated with not less than ..... pounds of ..... creosote per cubic foot of wood, in accordance with the specifications for creosoting timber. The creosote used in impregnating the timber shall conform to the requirements of the specifications for this class of material, hereinafter referred to.

**Inspection.** The quantity of creosote forced into the poles shall be determined by tank measurements, by weighing and by observing the depth of penetration of the oil into the pole. In the case of poles having a growth of sapwood not less than one and one-half ( $1\frac{1}{2}$ ) inches in thickness, the depth of penetration shall not be less than one and one-half ( $1\frac{1}{2}$ ) inches. In the case of poles having a growth of sapwood less than one and one-half ( $1\frac{1}{2}$ ) inches in thickness the creosote shall penetrate through the sapwood and into the heartwood. The depth of penetration shall be determined by boring the pole with a one-inch auger. The right is reserved to bore, for this purpose, two holes at random, about the circumference, one hole five or six (5 or 6) feet from the butt and one hole ten (10) feet from the top. After inspection, each bore hole shall be filled with hot creosote and then with a close-fitting creosoted wooden plug.

The inspector may satisfy himself that no portion of the increased weight is due to the presence of water, which may have condensed in the timber in consequence of the steaming process, or in consequence of the presence of water in the oil.

**Subsidiary Specifications.** The following specifications and drawing form a part of these specifications:

Specifications for creosoting timber.

Specifications for creosote.

Drawing No. . . . . Framing of Poles.

**13. CREOSOTING OF POLES.** These specifications cover all directions necessary for the treatment of timber, other than Douglas fir, with creosote. These specifications do not cover the treatment of cross-arms and are not to be used in connection with such treatment.

**General.** These specifications describe the processes to be used in impregnating timber, except cross-arms, with creosote and are intended to include all instructions necessary for the proper performance of the work.

**Testing Facilities.** The manufacturer shall provide and install such apparatus as is necessary to enable the inspector to determine that the requirements of these specifications are fulfilled. It is suggested that recording temperature and pressure instruments be provided.

**Workmanship.** All material shall be of the best quality unless otherwise specified herein, and all workmanship shall be sound and reliable in character and of the best grade.

**Timber.** The timber subjected to the creosoting treatment shall conform to the requirements of the specifications and drawings furnished by the purchaser. All timber shall be framed, shaped and bored before treatment. The material in each charge shall be in approximately the same condition so far as air seasoning is concerned, and under no circumstances shall green, partially seasoned, or seasoned timber be treated together in the same charge. Species of entirely different characteristics shall not be treated together. When the southern yellow pines are treated, long leaf and Cuban pine shall not be included in charges with short leaf and Loblolly pine.

**Creosote.** The creosote used in impregnating the timber shall conform to the requirements of the purchaser's specifications for creosote. The purchaser shall have the right to take samples of the oil whenever his inspector shall elect. The sample of oil so collected shall be tested wherever the purchaser shall elect. When timber is being treated, the oil may contain not more than five (5) per cent of water. In case more than two (2) per cent of water is present in the oil, the quantity of the preservative added to the timber shall be increased by an amount sufficient to ensure that the required amount of oil computed on a water-free basis has been taken up by the timber.

**Quantity of Oil.** All timber shall be so impregnated with creosote that the average impregnation of the material in each cylinder load shall not be less than the quantity of oil called for in the specifications for the material or in the contract. The volume of timber and the quantity of oil absorbed shall be determined by the inspector. The inspector shall have access to all records of treatment. Excess of oil in one charge shall not be offset against a shortage of oil in another

**Sec. 9**

**WOOD PRESERVATION**

charge. The treating plant shall be equipped, to the satisfaction of the purchaser, so as to allow a close determination of the amount of oil injected into the timber. The quantity of oil injected into the timber, as determined by the volume of oil withdrawn from the measuring tanks, shall be based on the standard temperature of 100° F. and the quantity increased by an amount equal to 0.00044 of the required volume at 100° F. for each degree of Fahrenheit of oil temperature above the standard temperature of 100° F.

**General.** The treating cylinder shall not be opened during the process of treatment, unless under instructions of inspector.

**Classification.** For the treating process timber shall be classified as heavy or small. Heavy timber shall be understood to include poles and stubs; small timber shall, unless otherwise specified, include all other timber, except cross-arms, ordered by the purchaser.

**Steaming and Heating Process.** Steam when used shall be maintained at a uniform pressure and temperature in the treating cylinder as indicated in the following table:

	Steam Pressure Not less than	Steam Pressure Not greater than	Steam Temper- ature Not greater than
For heavy timber . . . .	17 pounds	20 pounds	250 F.
For small timber . . . .	12 pounds	15 pounds	250 F.

The temperature reading shall be taken by means of standard thermometers placed in the treating cylinder so that the bulbs thereof are within the shell. At the beginning of the steaming process the exhaust valve shall be open and shall not be closed until a steady flow of steam escapes through the valve. The duration of the steaming process shall be timed from the closing of the exhaust valve. The exhaust valve shall be opened and the condensation blown off at intervals during the steaming process. The duration of the steaming process shall be as directed by the inspector and shall depend upon the condition and character of the timber, but shall in no case be carried to such an extent as to injure the timber. The timber shall not be steamed in excess of the interval given in the following table:

	Green or Very Wet Timber	Partially Seasoned Timber	Seasoned Timber
For heavy timber . . . . .	3 hours	5 hours	0 hours
For small timber . . . . .	5 hours	3 hours	0 hours

Seasoned timber shall not be steamed, but shall be heated in the treating cylinder. The temperature within the cylinder shall

be maintained by means of the closed heating coils at a temperature of about 150° F.

For heavy timber . . . . . for at least 2 hours  
 For small timber . . . . . " " " 1 hour

**Exhaustion Process Green and Partially Seasoned Timber.** When the steaming process shall have been completed the steam shall be blown off and the treating cylinder exhausted to a vacuum of at least twenty-four (24) inches at or near sea level, or proportionately less at higher altitudes. The vacuum shall be maintained at the above minimum for a period.

For heavy timber . . . . . of not less than 2 hours  
 For small timber . . . . . " " " 1 hour

and if necessary thereafter until the condenser discharge is clear. During the exhaustion process the temperature within the treating cylinder shall be maintained, by means of saturated steam in the closed heating coils, above that at which water would boil at that degree of vacuum.

**Exhaustion Process Seasoned Timber.** With seasoned timber it is not required that a vacuum shall be drawn after the heating process and before the filling process, provided that the specified amount of creosote is in the timber on its removal from the treating cylinder.

**Filling Process.** After the exhaustion process, the cylinder shall be completely filled, as rapidly as possible, with creosote and in no case shall the flow of oil into the treating cylinder be stopped before the overflow of the cylinder. Pressure shall then be applied until the specified amount of oil has been forced into the timber. The total amount of oil forced into the timber shall be determined from the initial reading on the measuring tanks, and from the readings on the measuring tanks, after the oil in the cylinder at the conclusion of the pressure process (including all drip from the timber), has been returned to the measuring tanks.

The oil at introduction into the cylinder shall have a temperature of not less than 140 degrees Fahrenheit and not more than 175 degrees Fahrenheit. The oil in the measuring tanks shall be maintained at a uniform temperature during the filling process.

**Subsidiary Specifications.** The following specifications of the purchaser form a part of these specifications:

Specification for . . . . . creosote.  
 Specification for analysis of . . . . . creosote.

**14. CREOSOTED PINE CROSS-ARMS. (Sec. 4, Art. 4.)**

**Inspection.** Inspection, unless otherwise arranged, shall be at the creosoting plant before and after treatment. All cross-arms shall be inspected for dimensions and defects outlined under "quality" before being subjected to the creosoting process. The quantity of creosote forced into the arms shall be determined by tank measurements and by noting the depth of penetration of the oil and by

weighing. The right is reserved to select, at random, one arm in each hundred to be sawed for the purpose of determining the penetration. All cross-arms not conforming to all requirements of this specification shall be rejected.

**Sapwood Classification.** No limitation is placed on the amount of sapwood which may be contained in any arm. All cross-arms containing both sapwood and heartwood shall, however, be shaped so that the sapwood shall be on the top or sides of the cross-arm. All crossarms shall be divided, before treatment, with respect to the amount of sapwood contained by each into three classes as follows:

- Class "H" not more than twenty-five (25) per cent of sapwood.
- Class "S" not less than seventy-five (75) per cent of sapwood.
- Class "I" not included in classes "H" and "S."

**Treatment.** Each class of cross-arms shall then be separately treated in accordance with the requirements of the "Specification for Creosoting Yellow Pine Cross-arms" hereinafter referred to, with the amounts of ..... creosote shown in the following table:

- Class "H" cross-arms not less than eight (8) pounds per cubic foot of timber.
- Class "S" cross-arms not less than twelve (12) pounds per cubic foot of timber.
- Class "I" cross-arms not less than ten (10) pounds per cubic foot of timber.

The ..... creosote used in treating the cross-arms shall conform to the requirements of the specifications for this class of material, hereinafter referred to.

**Subsidiary Drawings and Specifications.** The following drawing and specifications form a part of these specifications.

- Drawing No. .... standard cross-arm.
- Specification for creosoting pine cross-arms. ....
- Specification for ..... Creosote.

**15. CREOSOTING OF PINE CROSS-ARMS.**

**General.** This specification describes the process to be used in impregnating yellow pine cross-arms with creosote and is intended to include instructions necessary for the proper performance of the work.

**Testing Facilities.** The manufacturer shall provide and install such apparatus as is necessary to enable the inspector to determine that the requirements of these specifications are fulfilled. It is suggested that recording temperature and pressure instruments be provided.

**Workmanship.** All workmanship shall be sound and reliable in character and of the best commercial grade.

**Cross-arms.** The cross-arms subjected to the creosoting treatment shall conform to the requirements of the specifications and drawings furnished. All cross-arms shall be shaped, bored and well seasoned before treatment.

**Creosote.** The creosote used in impregnating the cross-arms shall conform to the requirements of the specifications for creosote here-

inafter referred to. The right is reserved to take samples of the oil at any stage of the creosoting process and to test the samples wherever desired.

**Water In Oil.** The inspector shall frequently take a sample of oil from the treating cylinder and distill it to two hundred and five (205) degrees Centigrade, in order to determine the percentage of water present. If the amount of water is in excess of five (5) per cent, the treatment shall be discontinued until the excess water has been removed from the oil or until oil containing not more than the allowable amount of water can be supplied. In case more than two (2) per cent of water is present in the oil, the quantity of the preservative added to the timber shall be increased by an amount sufficient to insure that the required amount of oil, computed on water-free basis, has been taken up by the timber.

**Quantity of Oil.** All crossarms shall be so impregnated with creosote that the average impregnation of the material in each cylinder load shall not be less than the quantity of oil hereinafter specified. The volume of timber and the quantity of oil absorbed shall be determined by the inspector. The inspector shall have access to all records of treatment.

Excess of oil in one charge shall not be offset against a shortage of oil in another charge.

The treating plant shall be equipped so as to allow a close determination of the amount of oil injected into the timber.

The quantity of oil injected into the cross-arms as determined by the volume of oil withdrawn from the measuring and working tanks, shall be based on the standard temperature of one hundred (100) degrees Fahrenheit. The correction to be applied in computing the quantity of the injected oil shall consist in the addition of .00044 of the required volume for each degree Fahrenheit the temperature of the measured oil exceeds the standard temperature of 100 degrees Fahrenheit.

**Treatment.—General.** The treating cylinder shall not be opened during treatment, unless so ordered by the Inspector.

**Classification.** For the treating process all cross-arms shall be divided, with respect to the amount of sapwood contained by each into three classes as follows:

Class H not more than 25 per cent of sapwood.

Class S not less than 75 per cent of sapwood.

Class J between classes H and S.

Each class of cross-arms shall be carried through the entire treating process separately. In no case shall a given cylinder load contain more than one class of cross-arms, nor shall it contain cross-arms of different sizes.

**Heating Process.** The seasoned and inspected cross-arms shall be placed in the treating cylinder, the temperature within which shall be maintained by means of the closed heating coils at a temperature of about one hundred and fifty (150) degrees Fahrenheit for at least one (1) hour.



**Exhaustion Process.** It is not required that a vacuum shall be drawn after the heating process and before the filling process, provided the specified amount of creosote can be injected into the timber without the previous application of a vacuum.

**Filling Process.** After the heating process or after the exhaustion process in cases where the latter is applied, the cylinder shall be completely filled, as rapidly as possible, with creosote, and in no case shall the flow of oil into the treating cylinder be stopped before the overflow of the cylinder. This shall be determined by means of an overflow valve at the top of the cylinder. All air must be removed from the cylinder before pressure is applied. Pressure shall then be applied until the amount of oil required for each class of cross-arms has been forced into the timber. Each class of cross-arms shall be impregnated with the amounts of creosote shown in the following table:

Class H cross-arms not less than 8 pounds per cubic foot of timber.
Class S cross-arms not less than 12 pounds per cubic foot of timber.
Class I cross-arms not less than 10 pounds per cubic foot of timber.

The total amount of oil forced into the cross-arms shall be determined from the initial reading on the measuring and working tanks, and the reading on the measuring and working tanks after the oil in the cylinder at the conclusion of the pressure process, including all drip from the cross-arms, after it has been returned to the measuring tanks.

The oil at introduction into the cylinder shall have a temperature of not less than one hundred and forty (140) degrees Fahrenheit and not more than one hundred and seventy-five (175) degrees Fahrenheit maintained at the initial temperature during the whole process of forcing the oil into the cross-arms.

**Subsidiary Specifications.** The following specifications form a part of this specification:

Specification.....	creosote.
Specification for analysis of.....	creosote.

**16. OPEN TANK SYSTEM.** The efficacy of treating the butts of poles by the open tank method is now fairly well recognized. It appeals at once to the operating man on account of its simplicity, and as the application of the oil is made at the butts of the poles where they are most susceptible to deterioration, the method is economical. Moreover, the process may be satisfactorily carried out by and under the control of the consumer. General directions are given in the following as a guide for carrying out the open-tank method of treating poles and crossarms.

**17. OPEN TANK TREATMENT OF POLE BUTTS.** All the inner bark should be thoroughly shaved from the poles in order that the best penetration by the oil may be secured. After cutting, the poles should be piled and stored in layers at least twelve inches above the ground with sufficient space between each pole and each layer to

allow for circulation of air, also to prevent the accumulation of snow and moisture, and to facilitate thorough seasoning. All poles should be at least air dried and have not less than three months' seasoning before treatment. Poles of different classifications or different species of wood should not be treated in the same charge.

**Hot Bath.** In the hot bath, the poles should be kept in oil maintained at a temperature of 200 to 220 degrees Fahrenheit, for from one to three hours.

**Cold Bath.** At the completion of the hot oil treatment, the poles should be placed in the cold oil, or the hot oil changed to cold oil, (oil at the temperature of surrounding atmosphere) for from one to three hours.

**Time of Treatment.** No attempt is made to specify the exact time of either the hot or cold treatment, because this can best be determined by trial. It is understood that a complete penetration of the sapwood should be secured.

**Control.** It should also be explained that where the apparatus is not equipped for both hot and cold baths, it will be necessary to permit the hot bath to cool down to the temperature of the atmosphere.

**Penetration.** Poles should be examined for depth of penetration of oil by boring samples at about four feet from the butt end. The bored holes should be filled with hot creosote oil immediately after the depth of penetration has been ascertained. The quantity of creosote oil injected should be determined by tank measurements. All tops and gains of poles should be brush-treated with two coats of hot oil. (See Article on Preservatives for specification for oil for brush treatments.)

**Treatment.** The cross-arms should be treated by immersing them for at least thirty minutes in hot oil at from 200 to 220 degrees Fahrenheit, and then leaving them in cold oil for one hour, or more. The necessary duration of each bath is best determined by trial. If complete penetration of sapwood is not obtained, the length of time should be proportionately increased.

Specifications have not been provided for a special oil for open tank treatments. It is true that perhaps excessive evaporation will result by using the ordinary oil, but the loss sustained is likely to be less than the extra cost of an especially prepared oil.

**18. DESCRIPTION OF OPEN-TANK PLANTS.** To meet the different local conditions existing among the member companies, four open-tank plants have been designed and the working plans referred to show the details of their construction:

1. Open-tank plant designated as "Type A."
2. Open-tank plant designated as "Type B."
3. Open-tank plant designated as "Type C."
4. Open-tank plant designated as "Type D."

Types "A," "B" and "C" are intended for the treatment of pole butts, while Type "D" is for the treatment of cross-arms.

It has been impossible to include the valuable detail drawings of

the different types of open-tank plants included in the 1911 report, owing to the fact that they could not be reproduced to a sufficiently large scale to be intelligible. For exact detail information, it will be necessary to consult the report as printed in full in the 1911 Proceedings of the National Electric Light Association. The original report should also be consulted for costs of the different types of open-tank plants; also for drawing and details of a portable tank for brush treatments.

**Open-Tank Plant Type "A."** This plant has a capacity of fifty poles per charge, and at least one hundred poles per day.

A plant of such ample size is recommended for the use of the larger companies who may find it advisable to construct a permanent plant and who use sufficient poles to warrant such an investment. It will be seen from the plan that a steam siding is included and a power-driven derrick, so that heavy manual labor will be reduced as much as possible. Liberal yard room is also provided at one side of the plant for the piling and seasoning of the untreated poles, and at the other for storing the treated poles.

The general layout of piping and tanks is so designed that this arrangement affords a plant which is easily controlled and operated. The oil bath in the treating tanks may be quickly changed from hot to cold. The storage tanks are elevated sufficiently above the treating tanks so that the oil will flow by gravity into the treating tanks. A plunger pump, having a capacity of 200 gallons per minute, is connected so that it discharges either from the receiving tank directly into the treating tanks, or into the storage tanks. A turbine drive, three-inch centrifugal pump may be substituted for the plunger pump, and the receiving tank eliminated, if found advisable. The piping shown is of liberal size, so that the time of changing the hot and cold oil will be reduced to a minimum. Steam coils are provided in the storage, receiving and treating tanks, and the area of the treating tank is sufficient, figuring two square feet of surface per pole, to accommodate 25 poles. Each storage tank is 10 feet in diameter, and 20 feet high, giving a capacity of about 11,500 gallons so that oil may be purchased in tank-car lots. The treating tanks contain sufficient heating coils to raise the temperature of the oil from zero to two hundred and twenty (220) degrees Fahrenheit. The coils are separated by 6-inch "I" beams, which have riveted on the top flanges 3½-inch by 2½-inch by 5/16-inch angle irons to support the poles. Angle irons are used instead of flat bars so that when the end of a pole is once placed on the bottom of the tank it will not change its position. The derrick intended for the outfit consists of an 8-inch by 10-inch boom, 4 feet long, two 8-inch by 8-inch stiff legs, each 40 feet long, one 8-inch by 8-inch mast, 30 feet long, and two sills 8 inches by 8 inches, 30 feet long, complete with derrick irons; one 10-foot diameter bull wheel with guide sheaves framed up complete, together with wire rope and clips to connect the bull wheel with the swinging gear. The derrick is equipped with ½-inch, cast steel cable, (hemp center) and with steel blocks having self lubricating bronze bushings. The engine

operating the derrick is a double 6¼-inch by 8-inch cylinder, tandem, friction drum hoist engine; drums being 14-inch diameter, 16-inch face equipped with ratchet pauls and foot brakes. The boiler is of the vertical locomotive type, 50 horse-power capacity.

It should be understood that the equipment may be modified to meet special requirements and a further description will not be dwelt upon, as local conditions governing each installation will have to be given due consideration. For example, in very moist ground, it would probably be advisable to build the plant high, rather than to excavate deep, and again, the capacity of the plant may be increased or diminished by changing the diameter of the treating cylinders, and by substituting a turbine driven centrifugal pump. Likewise a cheap derrick could be used with a steel cable runner, from a drum and engine located in the boiler house.

**Open-Tank Plant Type "B"** has a maximum capacity of 28 poles per day. This outfit is intended for a temporary pole treating plant for a large company, or as a permanent outfit for small concerns. A fairly good control of the oil is secured by the use of a centrifugal pump. The hot oil may be quickly pumped into the top of the storage tank and at the same time the cold oil is filling the treating tank. Hot and cold regulation of oil may also be accomplished without uncovering the poles. The tanks are heated with steam from a small locomotive type, 20 horse-power, vertical boiler, and if found desirable, the derrick may be operated by steam. The design, however, shows it operated by a hand winch. The plant has one 11,500 gallon capacity, storage tank. This is provided so that oil may be purchased in carload lots, thereby giving the consumer the benefit of the lowest price for the preservative. The scheme is flexible; there is no permanent foundation, and the plant may be moved from place to place.

Possible modifications of the type "B" open-tank outfit are apparent, as in the case of type "A." The treating tank shown is 6 feet in diameter. This could be increased to a diameter that would allow a proportionately greater number of poles per charge, thereby increasing the ultimate capacity. In the capacity figured above, (about 24 poles per day) it was estimated that the treating tank would be charged twice and a cycle of operation would be six hours. It would probably be possible to crowd the capacity to at least 36 poles per day. With either the type "A" or type "B" plants the special boiler equipment could be eliminated, if they were located adjacent to a permanent steam plant.

**Open-Tank Plant Type "C"** has a capacity of twelve poles per day.

Type "C" plant may be used where the number of poles to be treated is small and the pole treating is to be carried on in an isolated place. This plant is quite elementary. It is apparent that the regulation is poor, it being necessary to heat the oil to, say, 200 degrees Fahrenheit, retaining the temperature at or near that point for three hours, and then after drawing the fire, permit the oil to cool down to atmosphere. This operation gives a heavy treatment, with practically no control. The same outfit may be arranged

## Sec. 9

## WOOD PRESERVATION

without the fire box, having heating coils in the bottom of the tank, the coils being connected to an independent boiler or to a steam supply from an adjacent plant. Such a modification would give control of the hot treatment, but not of the cold.

Open-Tank Plant Type "D" is designed for the treatment of cross-arms, the capacity is approximately 300 cross-arms per day.

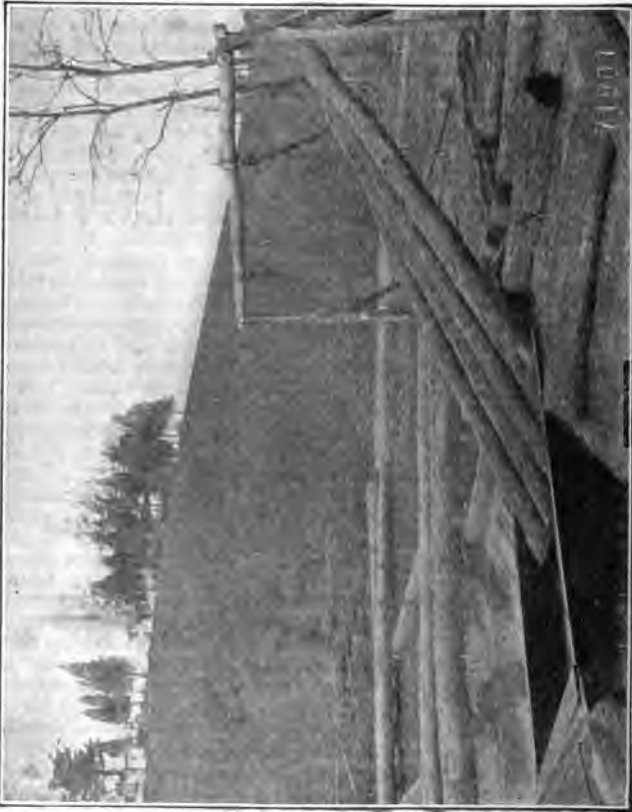

FIG. 360.

The cross-arm plant consists of two steel tanks, one for the hot and one for the cold oil, each 12 feet long, 3 feet wide and 2 feet high, arranged side by side. The hot oil tank is equipped with four pairs of 1½-inch steam coils, connected to a separate boiler, or to adjacent



FIG. 361



FIG. 362.

steam plant. Alongside the hot tank is a charging table, where the cross-arms are piled ready to be placed in the hot oil. After the seasoned arms are placed in the hot oil tank, the oil heated to 220 degrees Fahrenheit, the timber is kept submerged by means of cross

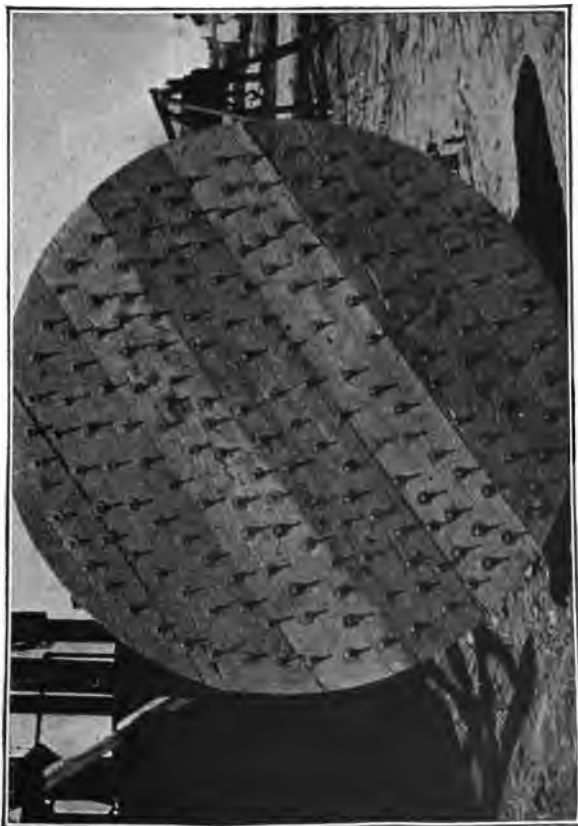

FIG. 363.

strips held in position by angle irons. After the hot bath, the strips across the top of hot tanks are removed and the cross-arms rapidly taken out with tongs and then submerged in the cold oil contained in the adjacent tank. After an hour's submersion, or when boring



tests show sufficient penetration, the cross-arms should be taken out and piled on the drip table to dry.

Figure 360 is from a photograph of an open-tank pole treating



FIG. 364.—These timbers were supposed to have had the same treatment. Notice erratic results obtained, due to adhering bark and unequal seasoning.

plant, in which the cost of handling the poles is reduced to a minimum, but this plant has but small capacity, and control of the cold bath is not obtained. Figures 361 and 362 show open-tank pole

treating plants that fairly well represent types "B" and "C." A false bottom for holding poles in position in bottom of treating tank is illustrated in Figure 363.

Wide variation in oil penetration resulting from unequal seasoning

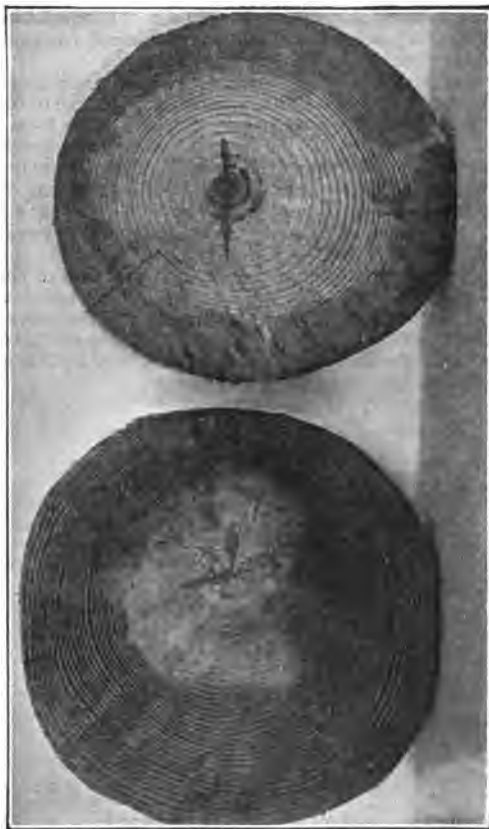

FIG. 365.—Sections showing treatment of seasoned and partly seasoned poles by open-tank method. Specimen on left seasoned. Specimen on right, green.

is illustrated in Figure 364. This shows timber supposed to have had the same treatment. Figure 365 shows a green and a seasoned pole of the same species, both treated by the open-tank method. The effect of seasoning on the efficiency of the treatment is very marked.

**19. BRUSH TREATMENT.** Much of the line timber treated at present is by the brush method. Although this treatment is less efficient than the pressure or open-tank system, it is recognized as often desirable and is used by many in the absence of more thorough methods. Unless absolutely unavoidable, the timber should not be treated when it is green, wet or frozen. It should be borne in mind that by not properly carrying out the brush treatment it is an easy matter to render the treatment worthless.

Coal tar, creosote oil (see specifications for oil for brush treatments, Articles on Preservatives) should be applied with a three or four knot rubberset or wire bound roofing brush, the oil having been heated to a temperature of 200 degrees Fahrenheit. All crevices and shakes should be filled with the oil, using the same liberally for the first coat. The second coat should not be applied until the preceding coat has been fully absorbed. It is best to apply the different coats on different days. Tops and gains of poles should also receive two brush coats of the preservative.

A spraying machine may be used for the application of the oil to the butts of poles. It has the advantage of filling up the cracks and season checks, and probably with this method the poles do not have to be handled so much as when the brush is used. However, the advantage of low cost of application is probably lost on account of the oil wasted in spraying the poles.

## **SECTION 9**

### **PRESERVATIVE TREATMENT OF POLES AND CROSS-ARMS**

---

**PART III**

**APPENDICES**

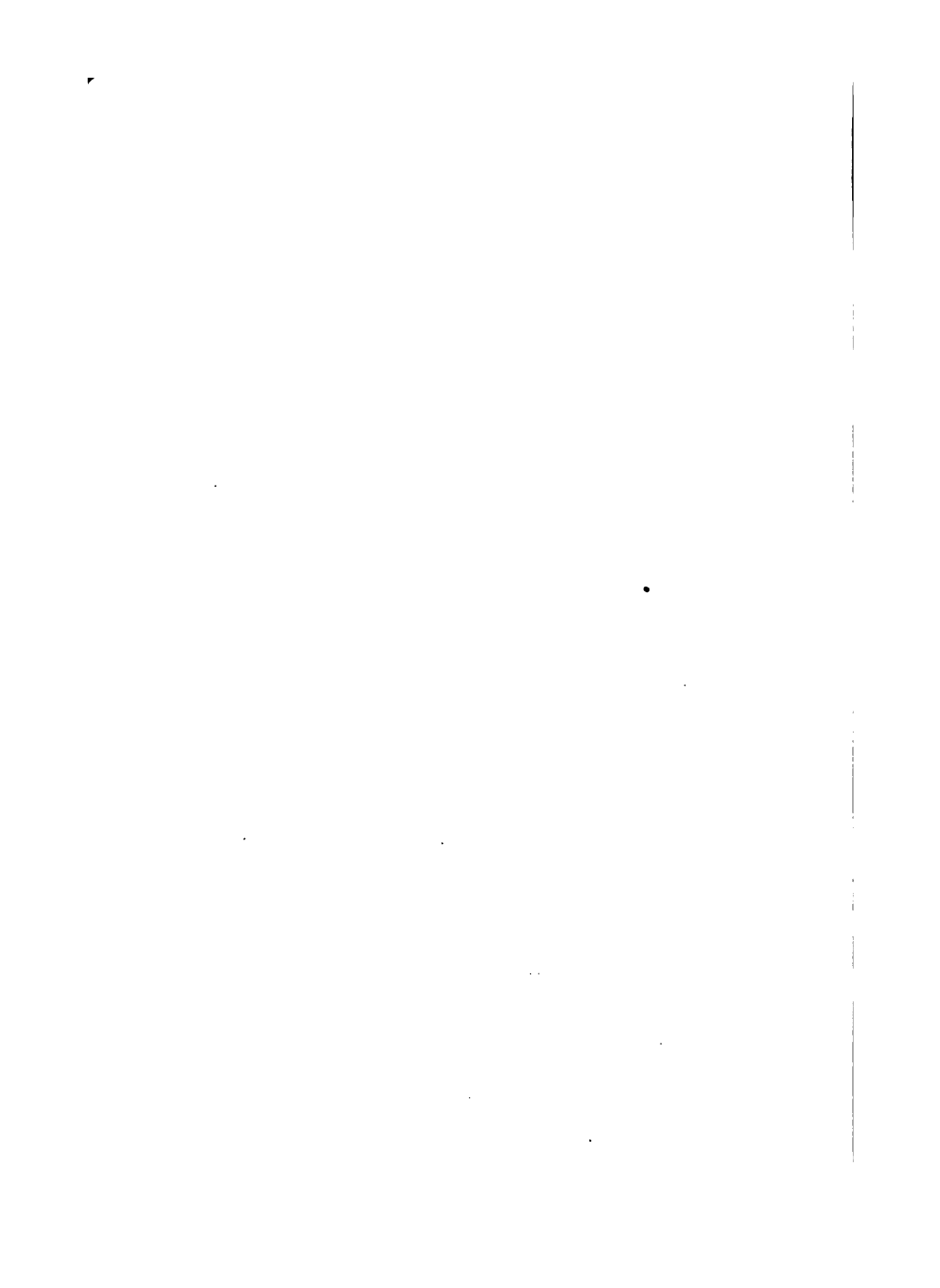

## **SECTION 9**

### **PRESERVATIVE TREATMENT OF POLES AND CROSS-ARMS**

#### **PART III. APPENDICES**

---

##### **Extracts from Report of Forest Service.**

Open-Tank Experiments on Western Yellow Pine.

Open-Tank Experiments on Western Red Cedar.

##### **Report of German Government—Telegraph Department.**

Relative Life and Value of Wood Poles.

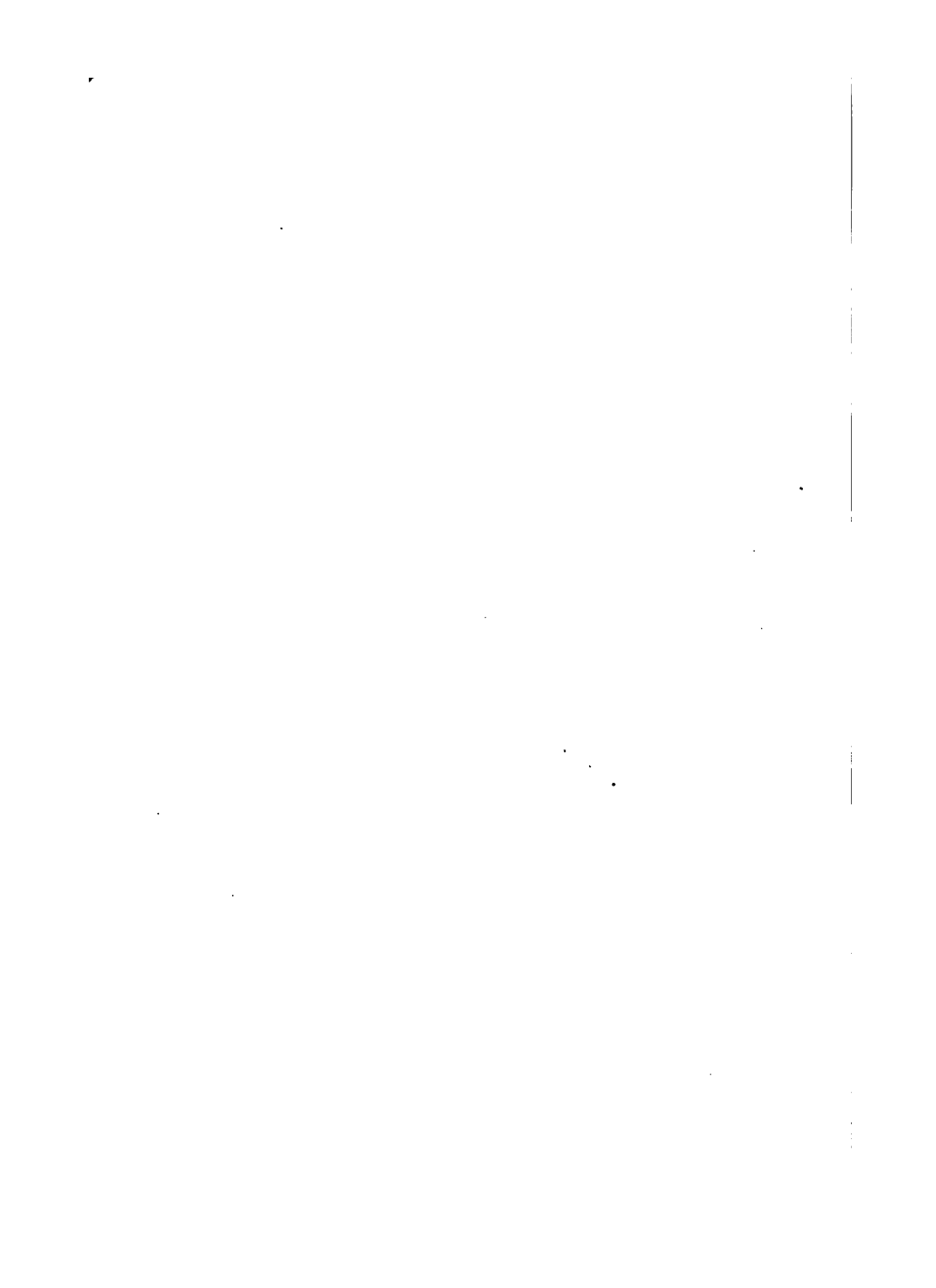

**EXTRACT FROM REPORT OF FOREST SERVICE—OPEN-TANK EXPERIMENTS ON WESTERN YELLOW PINE AND WESTERN RED CEDAR**

**TABLE 94**  
**POLE TREATMENTS, WESTERN YELLOW PINE**  
**Creosote—Open Tank**

Time of Cutting	Number Poles Averaged	Absorption per Cubic Foot Pounds	Penetration Inches	Moisture Content; Per Cent. of Green Weight Lost
Fall .....	11	15.03	4.3	48.0
Winter .....	22	11.03	2.7	51.5
Summer .....	2	1.92	1.0	55.2
Spring (seasoned).....	3	12.20	3.4	50.1
Spring (nearly seasoned) .....	4	11.06	3.03	50.0
Average .....	42	13.02	3.08	50.5

In the tables throughout the report the absorption is given in pounds per cubic foot of the treated section of the pole. The lower seven feet of the poles contain on an average 6.25 cubic feet. The penetration is given in inches at a point about five feet from the butt of the pole.

The following points were brought out:

1. The time of cutting the poles shows a marked influence on absorption. Summer-cut poles are difficult to treat, while the Autumn-cut takes the preservative most readily.

2. Good absorption can be secured without heating the oil to temperatures resulting in evaporation of the creosote. 130 degrees Fahrenheit was used as a maximum temperature with good results.

An average absorption of 13 pounds per cubic foot, and a penetration of 3 inches was secured by this treatment.

These poles have a heavy treatment. The wood-cells are full of free oil, and as the poles were removed from the cold oil they carried large amounts of it on their surface, much of which is wasted.

In an effort to overcome these disadvantages, the next series of treatments were given as the preceding series except that the oil was again heated to about 200 degrees Fahrenheit several hours before the poles were removed. The object of the reheating is to overcome this objection.

The results are presented in the following table: (Table 95.)



**TABLE 95**  
**POLE TREATMENTS, WESTERN YELLOW PINE**  
**Creosote—Open Tank**

Time of Cutting	Number Poles Averaged	Absorption per Cubic Foot (Pounds)	Penetration (Inches)	Moisture Content; Per Cent of Green Weight Lost
Fall . . . . .	9	14.16	5.25	54
Winter . . . . .	14	5.45	1.3	52
Summer . . . . .	20	7.10	2.2	54
Spring . . . . . (seasoned)	13	11.67	4.3	54
Average . . . . .	56	8.88	3.3	53

It is apparent that, with the exception of the Summer-cut poles, each cut has taken up less oil per cubic foot. The average penetration is better than in the series in which the poles were not reheated.

The average absorption of 8.9 pounds of oil per cubic foot with a penetration of 3.3 inches at the ground line is a satisfactory amount of oil for the result secured. Further, when poles are removed hot from the oil, the outer coating of oil which they carry on their surface, is drawn into the pole by the interior contracting air before it reaches the ground from the derrick.

Borings in poles treated in this manner show that the outer part of the wood is free from excess oil for a depth up to two inches, while in the lower part of the boring creosote is found free in considerable quantity.

The third plan tried with a single-tank system consisted in heating the poles in hot creosote several hours and allowing the oil to cool about 20 degrees, which required an hour, and then removing the poles from the partially cooled oil.

The 20 degrees fall in temperature draws in a small quantity of oil. The pole being now removed and allowed to cool to air temperature the contracting air in the wood draws the free oil in very deep, coating each passageway as it sinks in until no free oil is left in the cells. This secures the greatest protection for the smallest amount of creosote. The treatment is very successful, resulting in as deep a penetration as 3 inches with 5 pounds of oil per cubic foot of wood.

The preceding results were secured by a single bath treatment. Much time can be saved with an equipment permitting two baths of the preservative, one hot and one cold. This may be accomplished by two tanks or an arrangement for changing the oil in the single tank quickly. In this way the effect of the previously described 18-hour treatments can be secured in five hours, or less.

In the dry weather of Summer, if the poles are thoroughly seasoned,

penetrations of two to three inches with six pounds of oil per cubic foot can be secured by heating the poles for one hour in oil at 180 degrees Fahrenheit and then plunging them into air-cold oil for from two to five minutes. The poles are removed very hot, the surface oil is immediately drawn in and the poles are dry before they strike the ground.

Other variations in the tank treatment are possible.

The important conclusions to be drawn from the tank treating experiments with creosote upon western yellow pine are:

1. Poles should be well seasoned before treatment until they have lost 50 per cent of their green weight.

2. Poles should be separated according to season of cutting before treatment if possible. Summer-cut pine poles should not be treated with other poles, as they require a severer treatment.

3. Very old dry poles should not be treated in the same run with timber just seasoned.

4. Seasoned pine can be very successfully treated with creosote with absorptions up to 15 pounds of oil per cubic foot of treated timber and penetrations as deep as five inches.

5. The desirable form of treatment is an empty-cell treatment, which coats the interior of the walls and leaves no excess of oil in the wood.

6. The above treatment can be given with six pounds of oil per cubic foot or with four and one-half gallons to the average 40-ft. 8-in. pole.

7. The quantity of oil used can be controlled.

8. The time of treatment will vary according to the moisture condition of the timber as affected by relative humidity and recent rains.

9. Seasoned timber can be very readily treated with creosote in from one to five hours, according to its moisture condition.

10. Green and half-seasoned poles cannot be creosoted successfully.

11. Poles not well seasoned should be treated by heating for several hours at 215 degrees Fahrenheit and plunging into cold oil until the poles are cold. This is a forceful treatment, and the result will depend upon the moisture condition of the poles.

12. The treatment is best applied to seasoned poles as follows:

a. By heating the poles for one hour at 180 degrees, cooling the oil to 160 degrees, reheating to 200 degrees, and withdrawing the poles hot.

b. By heating the poles for one hour at 180 degrees, plunging them in cold oil for five minutes and removing.

c. By heating as above and holding in cold oil until desired absorption is secured and then removing.

**Tank Treatments with Crude Petroleum.** The poles in the table below were heated in crude oil at 200 degrees Fahrenheit for two or three hours and then allowed to cool in the oil over night, making a total time of treatment of 18 hours.

The Fall-cut poles show the best absorption. The average absorption of the other cuts is 3.68 pounds per cubic foot with a pene-

**TABLE 96**  
**POLE TREATMENTS, WESTERN YELLOW PINE**  
**Crude Petroleum—Open Tank**

Season of Cutting	Number Poles Average	Absorption per Cubic Foot (Lbs.)	Penetration (Inches)	Moisture Content; Per Cent of Green Weight Lost
Fall . . . . .	13	13.47	2.7	55.7
Winter . . . . .	2	2.35	1.5	53.0
Summer . . . . .	2	3.94	1.5	55.0
Spring . . . . . (seasoned)	1	16.20	3.0	59.4
Spring (partly seasoned)	6	2.86	1.13	50.7
Average . . . . .	11	3.63	1.4	53.0

tration of 1.4 inches. A six-hour treatment of Fall-cut poles, consisting of heating for three hours at 200 degrees Fahrenheit, cooling in three hours to 160 degrees Fahrenheit, and then removing the poles, gave an average absorption of 9.27 pounds per cubic foot with 1.25 inches penetration.

The conclusions respecting tank treatments with crude oil are:

1. Western yellow pine must be thoroughly seasoned, not less than 50 per cent of the original green weight being evaporated before treatment with crude oil.

2. Crude oil is weakly antiseptic, and should therefore be used only on very dry timber and in cell-filling quantities.

3. From three and one-half to 13 pounds of oil per cubic foot of timber, immersed according to the season of cutting, can be forced into seasoned pine with penetrations of from one to three inches. Fall-cut timber treats by far the most easily.

4. The time of treatment will vary from six to eighteen hours.

**Treatments with Creosote and Crude Petroleum.** To secure an antiseptic-treated surface upon poles treated with crude oil, it was proposed to give the hot bath in creosote and the cold bath in crude oil. Six poles treated in this manner gave an average absorption of five pounds of oil per cubic foot of timber with a penetration of 1.7 inches.

This treatment is not recommended, for it is difficult to keep the amount of creosote absorbed as low as desired. Further, it is probable that the crude oil mixes with the outer creosote and weakens the strength of the wood-cell coating of creosote.

**Tank Treatment with Zinc Chloride.** The table below shows the result of holding the poles at 170 degrees to 200 degrees Fahrenheit in a zinc chloride solution for two to three hours and allowing the poles to cool with the solution. The treatments were started with a

seven per cent solution of the salt and varied to a point showing a specific gravity of 1.03. (Table 97.)

Season of Cutting	Number of Poles Averaged	Absorption per Cubic Foot (Pounds)	Moisture Content; Per Cent of Green Weight Lost
Autumn.....	20	23.65	56.2
Winter.....	6	17.70	55.0
Spring.....	6	17.70	..
Summer.....	16	11.04	56.8
Average.....	48	17.90	..

The zinc chloride solution is the most readily absorbed of any of the preservatives. Borings and chemical analyses proved that pure zinc chloride was present in large quantities at a depth of five inches, and that in many poles a much larger quantity was present than necessary. The use of hot and cold baths shortens the time of treatment. Three hours divided between a bath at 150 degrees Fahrenheit and a cold bath resulted in an absorption of 12.5 pounds of the solution per cubic foot. Merely standing the poles in a cold solution for 15 hours gave an absorption of 9.7 pounds per cubic foot of timber.

The conclusions for this treatment are:

1. Pine should be well seasoned (at least 50 per cent of green weight being evaporated) before treatment with zinc chloride.
2. Greener timber can be treated with this preservative than with the oils.
3. Seasoned timber can be treated in from two to six hours.
4. The amount of zinc chloride per cubic foot and the depth of penetration is under control by varying the strength of the solution and the time of treatment.
5. The water of the zinc chloride solution should be dried out before the poles are set in the soil. Two weeks proved sufficient to evaporate this water.
6. There is no difficulty in securing an absorption of one-half pound of pure zinc chlorides per cubic foot, the usual commercial practice. This can be secured with a two per cent to three per cent solution of the salt.

**Tank Treatments with Creosote and Zinc Chloride.** This is a combination treatment designed to secure a narrow creosote-treated belt of wood around an interior full of zinc chloride. The reasons for this treatment lie in the facts that zinc chloride is inexpensive

Sec. 9

WOOD PRESERVATION

but soluble in water and so subject to leaching out of the wood, while creosote is insoluble and stable but expensive.

In practice the treatment is effected by heating the poles in creosote and cooling them in zinc chloride solution, which passes through the creosoted exterior to the interior of the pole. Poles were successfully treated in this manner.

This treatment is not recommended, because of the great difficulty experienced in controlling the amount of creosote absorbed in the hot bath and holding it to a minimum in very dry poles.

**Summary of Absorption Results.** The absorptions tabulated below present the actual results of the successful classes of treatment discussed in the preceding pages: (Tables 98, 99, 100.)

TABLE 98 AVERAGE ACTUAL RESULTS SECURED				
Preservative	Application	Absorption; Pounds per Cubic Foot	Penetration (Inches)	Treatment Recommended Pounds per Cubic Foot
Creosote . . .	Brush—1 coat	.4	$\frac{1}{8}$	Same
Creosote . . .	Brush—2 coats	.6	$\frac{1}{4}$	Same
Carbolineum	Brush—1 coat	.5	$\frac{1}{8}$	Same
Carbolineum	Brush—2 coats	.8	$\frac{1}{4}$	Same
Creosote . . .	Tank—full cell	13.0	$\frac{3}{4}$	10
Creosote . . .	Tank—empty cell	8.9	$\frac{3}{4}$	6
Crude oil . . .	Tank	3.5 to 10	1 to 3	6
Zinc chloride	Tank	17.9 (solution)	Complete	$\frac{1}{2}$ lb zinc chloride

TABLE 99 WESTERN YELLOW PINE Estimated Annual Service Charge 40-ft. 8-in. Poles						
Species	Treatment	Cost of Poles		Esti- mated Average Life (Years)	Equivalent Annual Charge at 5%	Added Life Necessary to Pay for Treatment (Years)†
		In Yard	In Line*			
Cedar . . . .	None	\$3.00	\$11.00	10	\$1.425	
Yellow Pine	None	5.00	3.00	3	2.94	
Yellow Pine	Crude o.	5.61	3.61			$\frac{1}{2}$
Yellow Pine	Creosote brush	5.19	3.19	4	2.55	$\frac{1}{2}$
Yellow Pine	Carbolineum brush	5.43	3.43	5	2.01	$\frac{1}{4}$
Yellow Pine	Zinc chloride	5.54	3.54	9	1.20	$\frac{1}{2}$
Yellow Pine	Creosote 10 lbs.	6.82	9.82	20	.78	$\frac{1}{4}$
Yellow Pine	Creosote 6 lbs.	6.25	9.25	20	.74	$\frac{1}{4}$

\* Including framing, hauling and erecting, but not stepping, shaving or painting.  
† Estimating the life of untreated pine at three years.

**TABLE 100**  
**POLE TREATMENT—WESTERN YELLOW PINE—COM-**  
**PARATIVE COSTS OF TREATMENT, STANDARD**  
**40-FOOT POLE, WEIGHING 800 POUNDS,**  
**TREATING 6¼ CUBIC FEET**

Preservative	Application	QUANTITY		COST OF PRE-SERVATIVE		Handling Charge per Pole	Total Cost of Treatment per Pole
		Per Cu. Ft. Lbs.	Per Pole Lbs.	Per Pound	Per Pole		
Creosote . . . .	Brush	.4	2.50	\$0.0235	\$0.06	\$0.05	\$0.11
Creosote . . . .	1 coat						
Creosote . . . .	Brush	.6	3.75	.0235	.09	.10	.19
Carbolineum	2 coats						
Carbolineum	Brush	.5	3.12	.066	.21	.05	.26
Carbolineum	1 coat..						
Carbolineum	Brush	.3	5.00	.066	.33	.10	.43
Carbolineum	2 coats						
Creosote . . . .	Tank	10.0	62.50	.0235	1.47	.35	1.82
Creosote . . . .	Tank	6.0	37.50	.0235	.09	.35	1.24
Crude petroleum . . . . .	Tank	6.0	37.50	.007	.26	.35	.61
Zinc chloride	Tank	.5	3.12	.06	.19	.35	.54
Creosote and zinc chloride	Tank	1.0	6.25	.0235	.15	.35	.09
Creosote and zinc chloride	Tank	.5	3.12	.06	.19		

### WESTERN RED CEDAR

**Tank Treatments with Creosote.** Thoroughly seasoned cedar poles of the Fall and Summer cut, treated after seasoning to 23 pounds per cubic foot, showed an average absorption of seven pounds per cubic foot of timber immersed. The penetrations varied from .2 to 1.5 inches and averaged .7 of an inch at a point corresponding to the ground line of the pole in service.

These figures are the average of those obtained by treating 126 poles in a single bath of creosote heated to 200 degrees Fahrenheit to 225 degrees Fahrenheit for from two to six hours, and then allowing the poles to cool in the oil until the following morning, making a total time of treatment, including handling, of 24 hours or one run per day.

There is no difference in the absorption of Summer-cut and Fall-cut poles as in the case of yellow pine. One reason for this fact is that cedar is all heart-wood except an outer band of sap-wood from one-half to one and one-half inches thick. The heart-wood cannot be penetrated by this process, but the narrow sap-wood band of well-seasoned poles can be completely filled with oil irrespective of the season of cutting.

When the heart-wood is protected by a band of sap-wood filled with creosote the pole is exceedingly decay resistant.

In order to reduce the time of treatment, experiments on Fall-cut poles seasoned to 23 pounds were tried with hot and cold tanks of oil. The poles were heated from three to six hours in the hot bath and then plunged into the cold bath for a limited period. The results are tabulated below: (Table 101.)

Number Poles Averaged	Total	HOURS OF TREATMENT		Absorption (Pounds per Cubic Foot)	Penetration (Inches)
		Hot Bath	Cold Bath		
8	3	2	1	3.3	.43
4	4	3	1	2.5	.35
4	4	2	2	2.9	.39
6	5	4	1	3.3	.45
4	6	4	2	3.3	.50
126	18	Hot bath cooling to air temperature		7.0	.79

Short runs can apparently be made with success. From the tabulation it cannot be said what period can best be used in practice, but it is safe to say that a six-hour run will result in an absorption of 3.8 pounds per cubic foot and a penetration of one-half inch.

Winter-cut poles treated with creosote after seasoning to 25½ pounds per cubic foot could not be well treated in short runs. Seven hours in the hot bath followed by one-half hour in the cold bath gave an average absorption of but 1.6 pounds of oil per cubic foot and a penetration of one-eighth inch. These poles were best treated by leaving them in the tank while the oil was heated for about three hours, cooled two hours, reheated two hours, and then permitted to cool over night. The oil absorbed in the first heating and cooling aids in the second heating and cooling. Upon 22 poles this treatment resulted in an average absorption of 4.4 pounds of oil per cubic foot and a penetration of one-third inch.

Two and three hours' heating, and allowing the poles to stand over night resulted in three pounds absorption and one-quarter inch penetration. It can be readily seen that poles at 25½ pounds absorb about one-half as much oil as when they are seasoned to 23 pounds. Further, the treatment in the latter case is much shorter.

Experiments with the Spring-cut poles proved that poles seasoned to but 23 pounds cannot be successfully creosoted.

A few old, dry poles from a pile in the Pacific Electric Company's yards were treated to show the possibilities with thoroughly seasoned poles. The results follow: (Table 102.)

Treatment		Absorption (Pounds per Cubic Foot)	Penetration (Inches)
Hot Bath (Hours)	Cold Bath (Hours)		
4.....	0	2/8	1/8
3.....	20 minutes	3	3/8
5.....	5 "	4	3/8
1.....	1 "	7	3/8
2.....	1	5	3/8
3.....	1	5	3/8

The important conclusions are:

1. Poles should be seasoned to 25 pounds per cubic foot before creosoting. Better results are secured after seasoning to 23 pounds per cubic foot.

2. The time required for creosoting timber seasoned to 25 pounds per cubic foot will vary from seven to 24 hours according to the result desired. Two runs per day per tank can be made, one giving an absorption of one and one-half pounds per cubic foot, and the second an absorption of three pounds, or one daily run may be made with an absorption of four and one-half pounds per cubic foot. As the poles become dryer the absorptions increase.

3. The best absorption and penetration is secured when the poles are seasoned to a weight of 23 pounds per cubic foot. At this stage the sap-wood can be completely filled with creosote with about five gallons of oil per average pole.

4. Poles seasoned to 23 pounds per cubic foot may be creosoted in six hours and less with an absorption of 3.8 pounds per cubic foot and a penetration of one-half inch. This amounts to about three gallons of oil per pole.

5. The sap-wood of cedar poles seasoned to 23 pounds can be completely filled in a 24-hour single bath treatment with an absorption of seven pounds per cubic foot or approximately five gallons of oil per pole.

**Tank Treatments with Crude Petroleum.** Cedar cannot be successfully impregnated with crude oil in an open tank. Even with thoroughly seasoned poles but slight absorption and penetration can be obtained—barely more than a coating of oil.

**Tank Treatments with Zinc Chloride.** Treatments upon the



partially seasoned poles of the Spring-cut with a water solution of zinc chloride prove that three pounds of solution per cubic foot can be forced into poles seasoned only to a weight of 31 pounds per cubic foot. This required a 24-hour treatment consisting of heating several hours at 210 degrees Fahrenheit and allowing the poles to cool in the solution over night.

Poles seasoned to 25 pounds per cubic foot absorbed about four pounds of seven per cent solution per cubic foot in short runs, consisting of two hours in each bath or a total of four hours. One hundred and three poles, seasoned to 23 pounds per cubic foot, treated in a zinc chloride solution heated to 210 degrees Fahrenheit for one to four hours and allowed to cool, averaged an absorption of four pounds per cubic foot. This treatment is unnecessarily long for poles so well seasoned. The same results apparently can be obtained in four hours by hot and cold baths. In these treatments the strength of the solution varied from three per cent to 10 per cent.

The conclusions for this preservative are:

1. Greener poles may be treated with zinc chloride solution than with creosote. Poles seasoned only to 31 pounds per cubic foot will absorb three pounds of solution per cubic foot in a 24-hour treatment.
2. The strength of the treatment can be controlled by the amount of the zinc chloride in solution. One-half pound of the pure chloride for each cubic foot of timber immersed is sufficient.
3. Poles seasoned to 25 pounds per cubic foot and below can be quickly treated in four hours with four pounds of solution.

**Tank Treatments with Creosote and Zinc Chloride.** This treatment should be used only on poles seasoned to at least 25 pounds per cubic foot. At this stage poles held in a bath of creosote at 212 degrees Fahrenheit for one hour or more, and then plunged into a solution of zinc chloride, will absorb about two-thirds pound of creosote per cubic foot in the hot bath and three and one-third pounds of solution in the cold bath.

Twelve zinc-treated poles which had evaporated the water of the solution were brush-treated with creosote, absorbing about half-pound of oil per cubic foot in two coats.

Poles freshly treated in a zinc solution will not absorb creosote upon being brush treated or plunged into a tank of oil.

## REPORT OF GERMAN GOVERNMENT—TELEGRAPH DEPARTMENT

### The Relative Life and Value of Wooden Poles

By GEH. OBER-POSTRAT CHRISTIANI, BERLIN<sup>1</sup>

The Government telegraph department has in its collection of statistics a rich, but unfortunately undeveloped, field for inquiry as to the life of wooden telegraph poles. All the upper postal directors transmit annually to the head office reports as to the condition at the beginning of the year of the wooden poles standing in the lines,

<sup>1</sup>Archiv. für Post und Telegraphie: Nr. 16 Berlin, August, 1905.

likewise the additions due to new construction, change of route, or replacement, and on the other hand, those lost from decay or other causes. These reports which cover the entire territory of the department are comprehensively summarized.

These statistics go back for the North-German and even the Prussian telegraph systems to 1852, and thus cover a period of more than 50 years. These statistics are of particular value, because the figures are separated as between untreated and treated poles, and furthermore separated as to the different treatments which have been used, as copper sulphate, zinc chloride, dead oil of coal-tar, and corrosive sublimate.

The thought then arises to calculate from this abundant material the average life of the different kind of poles and to draw conclusions therefrom as to the economical value of the different treatments. The occasion for doing this in a thorough manner has not previously arisen. Although Archive No. 23 for 1883 contained a paper on "The Average Life of Poles in the Government Telegraph Lines" it is merely a reprint of the statistics collected for the official year 1879-1880 and is without value as a basis for determining the average life. Another paper, by Kohlman, covering the subject matter, is to be found in Archive No. 5 for 1890, under the title, "The Different Processes of Protecting Wood Against Decay With Special Reference to the Conditions Which Are Involved in the Treatment of Telegraph Poles."

This noteworthy paper gives a detailed statement of the ordinary methods of treatment under the conditions prevailing at that time, and states among other things that fir (kieferne) poles of the usual dimensions have lives approximately as follows:

Untreated poles .....	4 to 5 years
Poles treated with copper sulphate .....	10 to 14 "
" " " zinc chloride .....	8 to 12 "
" " " dead oil of coal-tar .....	15 to 20 "
" " " corrosive sublimate .....	9 to 10 "

This statement, however, is not backed up with adequate figures. We shall see that different average lives follow from Government statistics, the publication of which, together with the data on which they are based, should fill a gap in the literature of the subject.

First of all we give an idea of the development of the network of lines upon which these observations have been made by means of the accompanying tabulation of the telegraph poles in the lines at the close of each year since 1852. (Table 103.)

The great proportion of poles treated with copper sulphate is apparent. Expressed as percentage per 100 poles there were at the close of 1903 treated with:

Copper sulphate .....	89.9
Zinc chloride .....	0.4
Dead oil of coal-tar .....	3.0
Corrosive sublimate .....	5.5
Other Methods .....	0.1
And Untreated .....	1.1
<b>Total .....</b>	<b>100.0</b>

**TABLE 103**  
**CHANGE IN THE NUMBER OF TELEGRAPH POLES**  
**FROM 1852 TO 1903**

At the Close of the Official Year	POLES WERE STANDING IN THE LINES				
	Treated With				
	Copper Sulphate	Zinc Chloride	Dead Oil of Coal-Tar	Corrosive Sublimate	Untreated
1852	..	1,983	..	..	..
1854	..	1,990	..	..	..
1856	..	5,751	..	..	942
1857	..	6,723	2	..	942
1858	562	8,185	2	105	952
1859	3,241	12,318	93	105	952
1860	12,136	18,783	566	105	960
1861	25,048	28,323	2,501	379	1,041
1862	46,246	44,983	3,270	2,072	1,420
1863	65,619	31,973	7,661	2,353	1,462
1864	76,926	50,233	13,268	2,636	2,263
1865	81,702	57,810	20,864	2,893	2,891
1866	80,811	64,005	29,628	2,893	3,574
1867	79,378	71,654	41,117	3,008	6,877
1868	77,306	75,447	70,224	3,425	9,943
1869	75,820	78,647	86,204	4,390	13,165
1870	72,828	81,125	97,704	5,854	15,510
1871	70,545	82,574	116,427	10,924	19,321
1872	69,940	85,009	125,630	12,884	22,535
1873	75,878	92,663	155,073	15,411	28,393
1874	96,767	107,074	159,268	18,803	28,638
1875	137,149	100,411	160,678	26,437	30,930
1876	188,615	86,668	160,016	31,283	29,811
1877	258,221	90,828	163,857	41,995	29,044
1878	350,202	77,079	156,044	67,474	
1879	429,834	66,357	148,323	77,571	
1880	482,878	56,941	138,683	81,111	Data
1881	522,572	49,519	134,792	81,849	Missing
1882	566,906	42,551	129,897	80,321	
1883	605,594	37,318	125,582	81,616	21,404
1884	613,604	32,817	124,663	85,272	19,277
1885	733,160	27,342	123,976	88,047	16,949
1886	803,493	23,671	119,693	91,393	12,730
1887	853,636	19,560	113,419	94,718	9,967
1888	943,348	17,121	110,678	97,131	7,779
1889	1,018,529	16,723	107,747	95,751	6,259
1890	1,105,656	15,642	103,999	92,278	5,436
1891	1,134,051	14,429	100,326	88,407	4,693
1892	1,267,842	16,791	96,684	83,845	4,156
1893	1,331,683	16,643	92,999	78,580	16,421
1894	1,439,379	17,296	89,332	74,330	21,962
1895	1,515,234	17,599	85,677	66,957	31,161
1896	1,585,001	17,851	83,640	59,298	42,682
1897	1,670,985	16,949	81,209	52,967	51,200
1898	1,784,312	16,579	81,306	47,392	55,257
1899	1,917,166	15,816	84,506	56,652	60,914
1900	2,111,952	15,089	90,338	74,770	87,332
1901	2,278,021	13,965	88,963	91,035	49,615
1902	2,428,930	13,469	88,254	125,196	39,830
1903	2,560,412	11,639	86,818	156,818	30,906

It might be mentioned here that the administration purchases almost its entire supply of wooden poles green and treats them at its own plants with copper sulphate. Moreover, for about five years, if only as a makeshift, it has provided for the delivery of kyanized poles by outside contractors. The two above-mentioned treatments—the cylinder treatments—with zinc chloride and with dead oil of coal-tar have on the other hand—excepting occasional experiments with tar-impregnated poles—been discontinued.

In order to obtain the total number of telegraph poles which have served as a basis for our tables, we have added to the poles which were in the lines at the end of 1903, the total number of poles, which, on account of decay and other causes, have been replaced since 1852. These totals are tabulated in the following table: (Table 104.)

Treatment	Poles Standing in the Line at the End of 1903	NUMBER OF POLES WHICH HAVE BEEN REMOVED BETWEEN 1852-1903			Total No. of Poles Under Observation
		On Account of Decay	From Other Causes	All Together	
Copper sulphate . . . . .	2,560,412	663,069	536,915	1,200,024	3,760,436
Zinc chloride . . . . .	11,689	172,822	33,323	206,210	217,909
Dead oil coal-tar . . . . .	85,818	33,630	32,049	175,679	268,497
Corrosive sublimate . . . . .	156,818	113,677	23,516	137,093	293,911
Other treatments . . . . .	2,106				2,106
Untreated . . . . .	30,895	76,813	15,257	92,070	122,965
<b>Total . . . . .</b>	<b>2,848,740</b>	<b>1,109,911</b>	<b>701,165</b>	<b>1,811,076</b>	<b>4,659,816</b>

During 52 years, 4,659,816 telegraph poles of different kinds have accordingly been under observation. Such a long period of observation and such an extraordinarily large number of observations which have occurred under the most varying local conditions have permitted the calculation of mean lives which can lay claim to general validity.

The restriction to a single line or to a shorter period of observation would afford no guarantee for the reliability of the average figures. For, on the one hand, the life of poles depends, for the same kind of treatment, to a large degree on the dimensions as well as on the species, on the age and on the conditions of growth of the tree from which the poles are obtained; on the other hand, on the character of the soil in which they are set and on the climatic influences to which they are exposed. This diversity of conditions could not but make itself felt in a small series of observations; it, however, is

**TABLE 105**  
**TABULATION OF THE POLES REMOVED FROM THE LINES BETWEEN 1852 AND 1882 ON**  
**ACCOUNT OF DECAY, AND THEIR LENGTH OF LIFE**

Life of the Poles Re-moved (Years)	POLES TREATED WITH											
	COPPER SULPHATE		ZINC CHLORIDE		DEAD OIL OF COAL-TAR		CORROSIVE SUBLIMATE		UNTREATED		POLES	
	Number Removed	Total Life Pole Years	Number Removed	Total Life Pole Years	Number Removed	Total Life Pole Years	Number Removed	Total Life Pole Years	Number Removed	Total Life Pole Years	Number Removed	Total Life Pole Years
1	392	822	637	637	106	106	7	7	6	6	6	6
2	2,063	4,126	1,202	3,604	220	440	85	170	53	106	53	106
3	5,248	15,744	4,699	14,097	435	1,305	187	561	123	369	123	369
4	6,327	25,308	5,983	23,952	823	3,292	435	1,740	393	1,573	393	1,573
5	6,366	31,830	7,854	39,270	1,024	5,120	707	3,535	632	3,110	632	3,110
6	5,691	33,546	9,042	54,252	1,705	10,230	1,141	6,846	732	4,392	732	4,392
7	4,913	34,391	9,851	68,957	1,823	12,831	1,487	10,469	927	6,489	927	6,489
8	5,147	41,176	9,911	79,283	1,824	17,472	1,694	8,752	924	7,392	924	7,392
9	4,759	42,831	11,337	102,033	2,289	26,091	1,425	12,825	499	4,491	499	4,491
10	4,629	46,290	10,871	108,710	3,114	31,140	1,694	10,940	171	1,710	171	1,710
11	4,676	51,436	11,586	137,446	3,100	34,100	1,978	10,758	424	4,664	424	4,664
12	3,895	46,740	7,848	94,176	2,861	34,332	1,726	8,332	114	1,368	114	1,368
13	3,561	46,233	7,439	96,529	2,721	35,373	1,655	6,396	30	396	30	396
14	4,822	63,368	6,738	95,032	2,177	39,478	232	4,083	21	315	21	315
15	3,297	43,105	4,438	66,570	1,323	23,995	165	2,475	144	2,304	144	2,304
16	3,122	49,952	4,007	64,112	1,131	18,096	130	2,080	30	510	30	510
17	2,521	47,957	3,752	63,794	1,905	15,385	151	2,567	225	4,050	225	4,050
18	2,620	47,160	3,349	60,232	550	9,900	174	3,132	210	3,990	210	3,990
19	2,085	39,615	1,958	37,145	151	2,969	190	3,610	..	..	..	..
20	862	17,240	798	15,920	35	700	105	2,100	..	..	..	..
21	594	11,094	241	5,061	41	864	9	189	..	..	..	..
22	146	3,212	106	2,310	62	1,364	..	..	..	..	..	..
23	83	1,969	..	..	..	..	..	..	..	..	..	..
24	..	..	..	..	..	..	..	..	..	..	..	..
25	47	1,128	..	..	9	207	..	..	..	..	..	..
Total	77,606	750,693	124,800	1,223,497	30,009	320,597	11,084	102,612	5,708	47,828	5,708	47,828

TABLE 106  
TABULATION OF THE POLES REMOVED FROM THE LINES BETWEEN 1882 AND 1903 ON  
ACCOUNT OF DECAY, AND THEIR LENGTH OF LIFE

Year	POLES TREATED WITH						CORROSYVE SUBLIMATE						UNTREATED POLES					
	COPPER SULPHATE		ZINC CHLORIDE		DEAD OIL OF COAL-TAR		COPPER SULPHATE		ZINC CHLORIDE		DEAD OIL OF COAL-TAR		CORROSYVE SUBLIMATE		UNTREATED POLES			
	Number Removed	Average Life Per Pole	Total Life Pole Years	Number Removed	Average Life Per Pole	Total Life Pole Years	Number Removed	Average Life Per Pole	Total Life Pole Years	Number Removed	Average Life Per Pole	Total Life Pole Years	Number Removed	Average Life Per Pole	Total Life Pole Years			
1883	8,436	9.4	79,148	5,168	14.0	72,352	2,774	14.9	41,433	2,286	9.5	21,717	4,658	8.0	37,264			
1884	11,117	9.1	101,165	4,799	14.8	70,075	3,250	15.1	78,773	2,914	9.3	27,100	5,065	8.9	45,078			
1885	13,252	9.4	124,569	4,419	14.5	64,517	3,258	14.4	43,255	4,107	9.1	37,373	4,523	9.3	41,657			
1886	14,366	9.0	128,754	3,521	15.3	53,971	3,172	16.3	51,768	4,512	9.7	45,766	3,448	9.7	33,445			
1887	18,329	9.0	164,961	3,657	15.5	57,049	3,395	16.7	56,637	5,001	10.0	50,010	2,670	9.2	24,564			
1888	20,373	9.3	189,469	2,916	14.4	41,990	3,231	17.2	56,835	5,122	10.2	52,234	2,169	9.5	20,606			
1889	21,686	9.3	200,376	2,790	16.5	46,314	2,860	17.6	50,856	5,424	11.4	61,333	1,857	11.0	17,127			
1890	23,294	9.9	230,611	2,063	16.2	33,259	2,631	18.8	62,453	5,549	12.8	68,252	766	11.3	11,413			
1891	24,831	10.2	250,216	1,754	16.8	29,467	3,322	18.9	47,884	4,871	12.0	58,452	1,016	11.3	8,962			
1892	25,562	10.7	273,513	1,513	17.4	26,326	2,801	18.9	52,958	5,625	12.8	71,000	808	11.7	7,191			
1893	25,161	10.8	271,728	1,216	18.0	21,388	2,754	18.9	50,353	5,338	12.9	71,437	460	11.7	3,956			
1894	34,066	10.4	353,682	1,495	17.0	25,415	2,609	19.3	50,353	5,772	13.7	79,076	581	11.7	8,616			
1895	34,756	10.7	371,869	1,128	17.5	19,352	2,230	19.4	43,028	7,026	14.6	96,364	332	9.9	3,287			
1896	39,221	11.1	435,333	1,099	16.3	17,914	2,240	18.9	44,226	7,718	14.6	112,682	1,172	8.7	10,196			
1897	34,970	11.1, 11.4	389,566	1,213	16.3	19,772	1,828	19.3	35,280	6,978	14.8	89,954	1,867	7.8	12,863			
1898	35,524	12.0	426,268	1,342	16.5	22,002	1,570	18.4	30,301	5,777	15.4	81,365	3,387	7.8	26,283			
1899	28,169	13.0	338,028	1,095	18.0	19,710	1,303	18.6	28,365	5,946	15.9	62,741	3,648	5.9	17,654			
1900	34,433	12.0	413,196	1,654	16.6	27,456	1,525	18.6	28,365	5,245	16.5	67,495	6,177	4.6	33,973			
1901	40,488	12.7	514,198	1,723	17.4	29,806	1,771	18.1	32,145	8,245	16.5	63,660	8,091	6.1	49,165			
1902	47,045	13.4	630,403	1,788	17.9	32,005	2,076	19.5	49,284	4,992	16.7	68,326	9,812	6.6	59,479			
1903	50,868	13.9	705,231	2,139	15.2	32,513	2,201	19.8	55,459	3,544	16.8	59,139	9,764	6.7	65,412			
Total	589,463		6,663,324	48,522		764,529	53,421		982,801	102,498		1,246,096	71,106		889,288			

**TABLE 107**  
**Supplementary to Table 106**  
**POLES IN SERVICE 20 YEARS AND OVER, REMOVED ON ACCOUNT OF DECAY**

Year	POLES TREATED WITH											
	COPPER SULPHATE		ZINC CHLORIDE		DEAD OIL		CORROSIVE SUBIMATE		UNTREATED POLES			
	Num-ber Re-moved	Pole Years to be Added Assuming 25-Year Life	Num-ber Re-moved	Pole Years to be Added Assuming 25-Year Life	Num-ber Re-moved	Pole Years to be Added Assuming 35-Year Life	Num-ber Re-moved	Pole Years to be Added Assuming 28-Year Life	Num-ber Re-moved	Pole Years to be Added Assuming 25-Year Life		
1883	1,308	..	916	..	154	..	97	..	69	..		
1884	1,616	..	1,362	..	488	..	83	..	212	..		
1885	2,102	..	1,062	..	498	..	11	..	125	..		
1886	1,514	..	1,044	..	778	..	13	..	89	..		
1887	1,445	..	953	..	945	..	116	..	63	..		
1888	1,341	..	677	..	1,290	..	97	..	64	..		
1889	1,034	..	696	..	1,243	..	111	..	202	..		
1890	953	..	388	..	1,328	..	178	..	62	..		
1891	1,321	..	583	..	1,356	..	138	..	63	..		
1892	830	..	483	..	1,890	..	131	..	54	..		
1893	1,095	..	607	..	2,063	..	144	..	24	..		
1894	2,114	..	823	..	1,850	..	344	..	69	..		
1895	2,768	..	631	..	2,163	..	791	..	47	..		
1896	4,237	..	454	..	1,889	..	1,151	..	36	..		
1897	4,569	..	485	..	1,619	..	1,069	..	11	..		
1898	5,905	..	532	..	1,418	..	1,903	..	6	..		
1899	5,199	..	437	..	1,046	..	1,513	..	8	..		
1900	6,679	..	660	..	1,374	..	1,602	..	15	..		
1901	8,281	..	713	..	1,250	..	1,864	..	21	..		
1902	10,965	..	942	..	1,849	..	1,606	..	19	..		
1903	11,333	..	1,003	..	2,654	..	1,432	..	70	..		
Total	77,335	386,675	15,348	76,740	29,753	446,395	13,898	111,184	1,320	6,600		

compensated if we can give the inquiry as broad a scope as was at our command for the calculations in question.

It must be kept in mind, however, that the figures for the average lives can only be considered as of reliable value for comparative purposes, when the new poles added each year to the lines are approximately constant. With increasing setting, the calculated average lives will be too small since the increasing number of the premature removal of the recently set poles depresses the result, while a decrease or a discontinuance of the yearly growth gives more favorable value to the figures.

Unfortunately, although as may easily be conceived, the method according to which the record of the deteriorated poles was obtained did not remain unchanged during the five decades. We must, on that account, divide our calculations into two distinct periods—from 1852 to 1882, and from 1883 to 1903. For the purpose of this study, it was necessary to recompute a portion of the yearly tabulations; still the final result was obtained without constraint and the correctness of the final result has not been invalidated on account of the variation in the basis figures.

It appears expedient to refer briefly to the fundamental difference in the methods which have been used for collecting the statistics for the two periods. During the first three decades the number of poles standing in the lines was annually recorded, and the annual removals recorded, until all the poles placed during a certain year had been removed from the lines; then the proper tabulation could be prepared and the average life determined.

That method was free from objection and had only one drawback, that each year a new summary had to be made and which had to be continued.

The increasing inconvenience from year to year and the lack of ready comprehensiveness which arose from the large number of tabulations, may well be given as the reason why in 1883 the statistics were substantially simplified and recorded in another form. The new scheme collects together the removals of each year and permits the average life to be calculated as the mean for all poles replaced during the year in question. The individual lives of the older poles would only be separately given up to 19 years, while the poles of longer life could be collected in a table for "20 years and over." The values determined in this manner are also affected by one inaccuracy, which, moreover, can only be allowed for by interpolation.

From the preceding compilation the number of poles removed on account of rot and their length of service is given in Table 105 for the period from 1852 to 1882, and in Table 106 for the years 1882 to 1903. In both tables the total duration in terms of pole years, that is the product of the number of poles and the actual lives, is given.

Table 106, covering the period from 1883 to 1903, requires a correction, because poles having a life of twenty years and over have only been credited with a life of twenty years. In order to correct this error, as above stated, to some degree, a retabulation 107 has



**TABLE 108**  
**AVERAGE LIFE OF DIFFERENT KINDS OF POLES**

Summary of	TREATED WITH												NOT TREATED	
	COPPER SULPHATE		ZINC CHLORIDE		DEAD OIL OF COAL-TAR		CORROSYVE SUBLIMATE		CORROSYVE SUBLIMATE		NOT TREATED			
	Removed on Account of Decay Poles	Total Life in Pole Years	Removed on Account of Decay Poles	Total Life in Pole Years	Removed on Account of Decay Poles	Total Life of Pole Years	Removed on Account of Decay Poles	Total Life of Pole Years	Removed on Account of Decay Poles	Total Life of Pole Years	Removed on Account of Decay Poles	Total Life of Pole Years		
Table 105..	77,606	750,693	124,300	1,223,497	30,009	320,597	11,084	102,012	5,708	102,012	47,528	47,528		
Table 106..	585,463	6,653,334	48,522	764,528	53,631	982,801	102,493	1,346,056	71,105	1,346,056	535,288	535,288		
Table 107..	..	386,675	..	76,740	..	446,295	..	111,184	..	111,184	6,600	6,600		
	643,069	7,790,702	172,822	2,064,765	83,640	1,719,693	113,577	1,559,292	76,813	1,559,292	589,416	589,416		
Resultant average life		11.7 years		11.9 years		20.6 years		13.7 years		13.7 years	7.7 years	7.7 years		

been made, which has been based on the assumption that the poles in question are capable of offering a resistance of about double the average life which poles of that type would attain: instead of twenty years the treated poles would have a life as follows:

Copper sulphate.....	25	years
Zinc chloride.....	25	"
Dead oil of coal-tar.....	35	"
Corrosive sublimate.....	23	"

and untreated poles 25 years. The surplus thus obtained has accordingly been added to the pole years already found.

We have now only to summarize the three Tables, 105, 106 and 107, and from the sum total calculate the average life of the different types of treated poles. This is tabulated in Table 108.

The results thus determined are of particular interest, as the assumption previously generally held considered that the most efficient treatment next to dead oil of coal-tar was copper sulphate. According to Table 108, however, this idea is proved to be erroneous, as in fact during the elapsed 50 years of all treated poles, those treated with copper sulphate have given the shortest average life. Contrary to expectations, corrosive sublimate gives the most efficient treatment next to the unrivaled dead oil of coal-tar, and the equally misjudged zinc chloride comes next, also ahead of copper sulphate. The untreated poles show up quite favorably as regards their durability. The reason for this is that during the first thirty years oak poles were used in excess, and they often remained in the lines over 20 years.

The differences which appear are striking if the average lives of each kind of pole are determined from each of the Tables 105 and 106. The values thus obtained could, however, make no pretense as being reliable; although in general it is noticeable that wooden poles now attain a longer life than formerly. An examination of the yearly values in Table 106 leads to a similar observation. This is not surprising in the case of those poles which have been treated with dead oil of coal-tar and zinc chloride, for they date from the earlier times. Only the most durable samples of their kind are now standing in the lines, and when replaced enter the records with long lives. For poles treated with copper sulphate and corrosive sublimate, the result can hardly mean other than that substantial progress has been made in the method of treatment. A further indication may be found therein which points to a greater efficiency in the maintenance work. In any case, we are justified in concluding that the poles which are now being installed in the lines will attain a greater average life than the above average figures.

The average lives are evidently not sufficient to estimate the economical value of the different treatments, but we must further take into consideration the cost of manufacture, the freight and the cost of erection of the poles. The latter figure, which should include a proper amount for the pole equipment, is the same for all treatments with the exceptions of the poles treated with dead oil

of coal-tar, which, on account of their greater weight and well-known inconvenience in handling, cause higher charges for freight and labor. The following table gives the economical value of the different kinds of treatment as computed on the above basis. The manufacturing and erection (including freight) charges are based on 1903 prices. The economical value is reduced for simplicity of comparison to the charge per cubic meter (of pole) per year. (Table 109.)

Kind of Treatment	Average Life (Years)	Manufacture		Cost per Cubic Meter for Freight and Erection		Total		Cost per Cubic Meter per Year	
		Mark	Pf.	Mark	Pf.	Mark	Pf.	Mark	Pf.
Copper sulphate . . . . .	11.7	28	96	20	..	48	96	4	19
Zinc chloride . . . . .	11.9	28	12	20	..	48	12	4	05
Dead oil coal-tar . . . . .	20.6	36	98	25	..	61	93	3	01
Corrosive sublimate . . . . .	13.7	32	89	20	..	52	89	3	86
Untreated . . . . .	7.7	20	30	20	..	40	30	5	30

The average annual cost in the last column is evidently only an approximate value, because, while the estimated lives extend over a series of years, the estimated costs only relate to the last year of observation. It follows in general, however, that the order of the treatments as regards their economical value is the same as the order of the average lives. Dead oil of coal-tar stands in first place. For this reason it is to be regretted that as yet no remedy has been found to counteract the disadvantages attendant with its use. Poles treated with corrosive sublimate stand in second place and its superiority over zinc chloride and copper sulphate treatments can no longer be doubted. The most unfavorable position in this economical relation is held by untreated poles, the annual cost of which is nearly twice as much as the best treated pole.

# **SECTION 10**

## **RECOMMENDATIONS OF THE COMMITTEE ON OVERHEAD LINE CONSTRUCTION, 1914**

---

### **PART I SPECIFICATIONS FOR METHODS OF CONSTRUCTION**

---

### **PART II METHODS OF SECONDARY SYSTEM WORK**

---

#### **COMMITTEE ON OVERHEAD LINE CONSTRUCTION**

THOMAS SPROULE, Chairman.

R. D. COOMBS,

W. T. OVIATT,

H. M. HOPE,

F. B. H. PAINE,

G. H. LUKES,

F. L. RHODES,

FARLEY OSGOOD,

PAUL SPENCER,

C. W. STONE.



## SECTION 10

### PART I—SPECIFICATIONS FOR METHODS OF CONSTRUCTION

#### TABLE OF CONTENTS

	ARTICLE
Scope.....	1
<b>Poles and Pole Setting</b>	
Specification.....	2
Height.....	3
Trimming.....	4-5
Cross-Arm Gains.....	6
Reverse or Buck-Arm Gains.....	7-8
Painting.....	9
Pole Numbering.....	10
Rights-of-Way.....	11
Street Rights-of-Way.....	12
Back Yard Rights-of-Way.....	13
Locating Poles on Street.....	14
Spacing.....	15
Street Crossings.....	16
Heavy Poles.....	17
Clearing Obstacles.....	18
Line Level.....	19
Curb Line.....	20
Pole Setting.....	21 to 26
Crib Bracing.....	27
Artificial Foundation.....	28
Quicksand.....	29
Poles Located in Rock.....	30
Protection.....	31
<b>Pole Steps</b>	
Poles to be Stepped.....	32
Galvanized Iron Pole Steps.....	33
Location on Pole.....	34-35
<b>Cross-arms</b>	
Cross-arms.....	36
Size Arms to Use.....	37
Painting and Treating.....	38
Cross-arm Bracing.....	39
Fitting Cross-arm to Pole.....	40
Attaching Braces to Pole.....	41

	ARTICLE
Location of Cross-arms .....	42
Side Cross-arms .....	43
Double Arms .....	44
Reverse or Buck Arms .....	45
Braces with Buck Arms .....	46
Pins .....	47
<b>Insulators</b>	
Equipping .....	48-49
<b>Pole Guying</b>	
When to Use Guys .....	50
Straight Line Guying .....	51
Terminal Poles .....	52
Long Spans .....	53
Corner Poles .....	54
Curved Lines .....	55
Poles on Hills .....	56-57
Guy Wire .....	58 to 60
Guy Fittings .....	61
Guy Attachments .....	62-63
Stub Guying .....	64
Anchor Guys .....	65
Patented Guy Anchors .....	66
Guy Anchor Protection .....	67
Locating Foot of Anchor Guy .....	68
Tree Guying .....	69 to 71
Method of Fastening Guys .....	72-73
Two Guys .....	74 to 76
Cross-arm Guys .....	77
Guy Before Running Wires .....	78
Clearance .....	79
Iron Poles .....	80
Guy Insulation .....	81
<b>Wire and Wire Stringing</b>	
Wire Sizes .....	82
Wire Insulation .....	83
Support of Wires .....	84
Wires Attached to Structures .....	85-86
Clearance .....	87 to 91
Tree Trimming .....	92-94
Running Through Trees .....	95-96
Abrasion Moulding .....	97 to 99
Tree Insulators .....	100
Line Sag .....	101-102
Tie Wires .....	103
Splicing Wires .....	104 to 106
Taps .....	107

## LINE CONSTRUCTION

Sec. 10

	ARTICLE
Branch Lines.....	108
Spreader Brackets.....	109
Pole Wiring.....	110
Neat Work.....	111
Line Terminals.....	112
Corners.....	113
Dead Wires.....	114
Reinforcing Wires.....	115
<b>Systems of Distribution.....</b>	<b>116 to 118</b>
<b>Carrying Capacity.....</b>	<b>119</b>
<b>Lines on Private Property.....</b>	<b>120</b>
<b>Location of Wires</b>	
Series Circuits.....	121
Multiple Circuits.....	122
Locations on Pins.....	123
Temporary Work to be Avoided.....	124



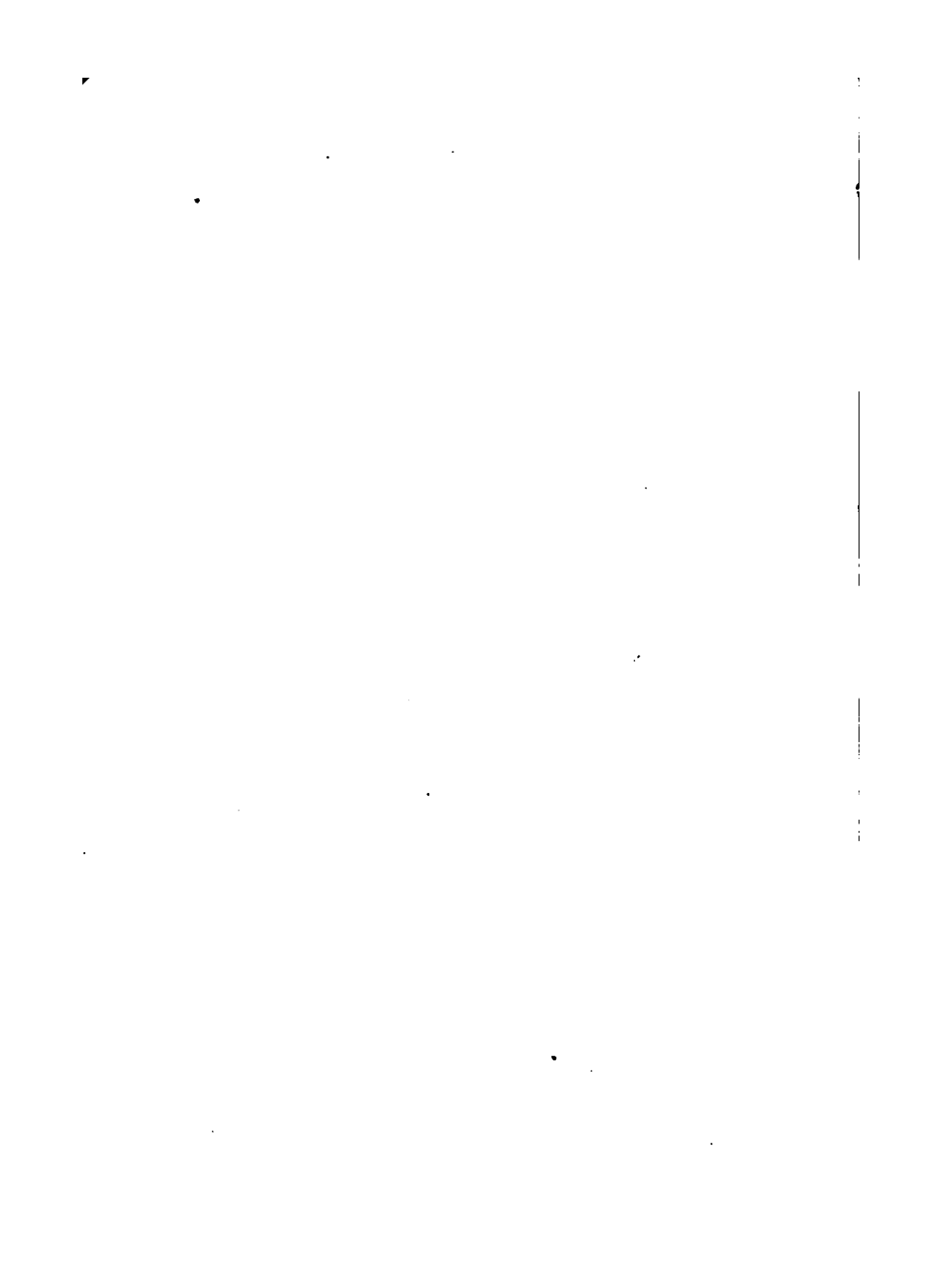

## SPECIFICATIONS FOR METHODS OF AERIAL CONSTRUCTION

1. **Scope.** These specifications cover construction methods for distributing systems as follows:—Mechanically, for spans up to and including 130 feet; electrically, for street lighting circuits and for constant potential circuits up to and including 6600 volts between adjacent wires on the same cross-arm. Higher voltages and longer spans may be used, provided the spacing between the wires, the type of insulators, sags, etc. are made consistent with such work. Railroad and wire crossing shall be made in accordance with the joint crossing specifications.

### POLES AND POLE SETTING

2. **Specification.** All poles shall be purchased under, and conform to the standard specifications for poles, (Sec. 2.)

3. **Height.** Unless special poles are required by municipal ordinance, or by exceptional conditions, the standard height of poles in cities or thickly settled localities shall be 35 feet for poles to carry either one or two cross-arms; 40 feet for poles to carry three or four cross-arms; and 45 feet for poles to carry over four cross-arms. For lines in suburban districts 30-foot poles may be used to advantage, and their use is recommended. In general, stability of construction is sacrificed by using poles higher than necessary. The height of a pole is always considered as the total length over all.

4. **Trimming.** Before being set, poles shall be well trimmed and shaved, every effort being made to have their appearance when set as unobjectionable as possible.

5. The top of each pole shall be roofed at an angle of 45 degrees, as shown in Fig. 366.

6. **Cross-arm Gains.** Gains and bolt holes for the cross-arms up to the expected carrying capacity of the line shall be cut in a pole before the same is set. Gains shall be cut square with the axis of the pole and with all other gains. Gains shall be  $4\frac{1}{2}$  inches wide to securely fit the cross-arms and shall be  $\frac{1}{2}$  inch deep and spaced 24 inches apart on centers, as shown in Fig. 366.

7. **Reverse or Buck-arm Gains.** Where reverse or buck-arms are to be placed on a pole, the cross-gains shall be cut at right angles to the line gains.

8. **Cross-arm gains, bolt holes and pole tops** shall be painted with at least one coat of preservative paint before the pole is set.

9. **Painting.** Poles that are to be painted in order to improve their appearance, shall be given a priming coat of standard green pole paint before being taken from the yard. After the pole is set and construction line work thereon has been completed, the poles

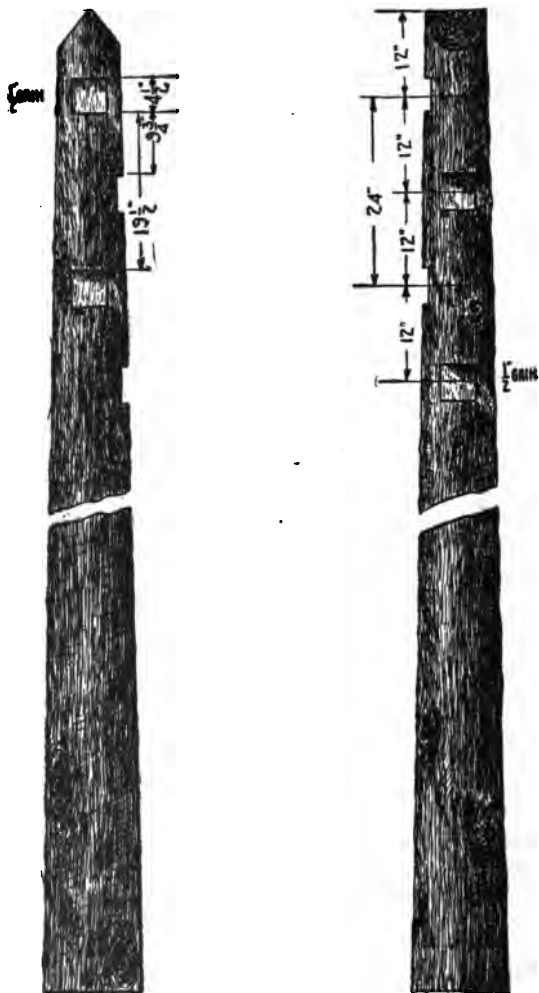

FIG. 366.—Pole framing.

shall be given a second or finishing coat of standard green pole paint. Cross-arm braces, pins, switchboxes, pole steps and other fixtures, shall be painted when this finishing coat is applied.

**10. Pole Numbering.** Every pole belonging to the electric light or power company and every pole that is the joint property of the company, and of some other company, should be numbered. The designating number of the pole shall be stencilled thereon as soon as possible after the pole has been set.

**11. Rights-of-Way.** In selecting the route of a pole line, it is important to consider the district through which the line will extend, as well as the probable business that can be connected to such a line.

**12. Street Rights-of-Way.** Lines should be arranged to follow one side of the thoroughfare as much as possible to reduce the number of crossings to a minimum. In designing a new line, care should be taken to obtain an unobstructed right-of-way, selecting a location which will not conflict with existing pole lines of other companies. It is undesirable to erect pole lines on the same side of the street as existing pole lines.

**13. Back Yard Rights-of-Way.** It will sometimes be found desirable to locate poles along the rear lot lines, but unless permanent rights-of-way are secured, such poles shall not be used for carrying important feeders or mains. Poles carrying feeders and mains shall preferably be located on public streets, not only because the rights-of-way are more permanent, but also because poles so located are available for supporting street lamps.

**14. Locating Poles on Street.** Efforts should be made to select the following locations for poles:

(a) At the junctions of all streets or alleys to facilitate the installation of branch lines, feeders and service connections.

(b) Poles in all cases should be located so as not to obstruct doorways, windows, porches, gates, coal holes, runways, etc.

(c) At railroad crossings unless physical conditions or municipal requirements prevent the side clearance should be not less than 12 feet from the nearest track rail of main line tracks and 6 feet from the track rail of a siding.

**15. Spacing.** On straight sections, wood pole lines for distribution work shall have a length of span approximating 125 feet. On curves and corners the spans shall be shortened as given in Table Fig. 367.

**16. Street Crossings.** When a line must cross from one side of a street to the other, the crossing shall be made with the smallest possible angle of deviation in the line, but the span should not exceed 110 feet. The spans on the straight lines next to and on either side of the crossing, shall also be shortened from the standard pole spacing of 125 feet to 100 feet or less.

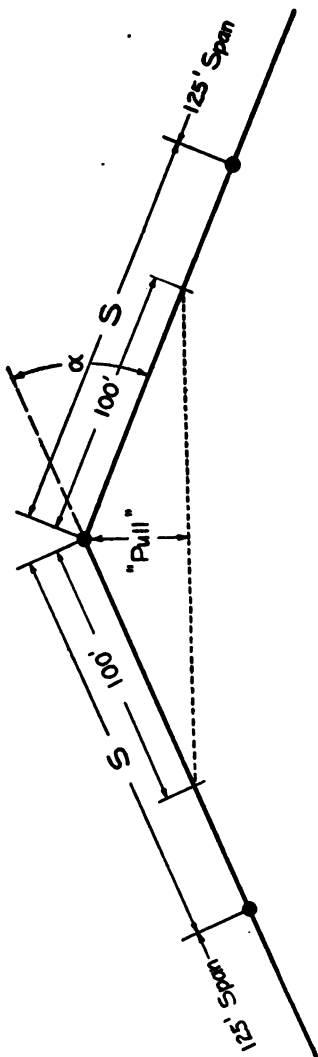

Note: If the "pull" is less than 5', the spans adjacent to the angle pole shall be the standard length (125'). If the "pull" exceeds 5', the spans adjacent to the angle pole shall be reduced to the distance 'S' given in table.

ANGLE $\alpha$	"PULL" IN FEET	SPAN S	No. of 6000 LB. SIDE GUYS	
			1 ARM 6 WIRES	2 ARMS 12 WIRES
Less than 6°	Less than 5'	125'	None	None
6°-11°	5'-10'	115'	None	1
11°-15°	10'-13'	105'	1	1
15°-22°	13'-19'	95'	1	2
22°-30°	19'-26'	85'	1	2
Over 30°	Over 26'	75'	1	2

FIG. 387.—Location of poles and side guys on curves.

**17. Heavy Poles.** The heaviest poles shall be placed at line terminals, corners, street crossings and other points of exceptional strain; and at such points the depth of pole setting shall be increased at least 6 inches, as specified in the table given in Art. 21. At all such points the length of adjacent spans shall be reduced from the standard pole spacing.

**18. Clearing Obstacles.** To clear obstacles, such as buildings, railroad gates, foreign pole lines, bridges, etc., poles shall be used of sufficient height and so located that there will be ample clearance between the obstacle and the nearest line wire.

**19. Line Level.** The length of poles shall be so proportioned to the contour of the country, or to adjacent poles of exceptional height set to clear obstacles, that abrupt changes in the level of the wires will not occur.

**20. Curb Line.** Poles set along a curb line shall be located so that there is a clear space of about 6 inches between the nearest surface of the pole and the outside edge of the curb. Poles on country roads where the curb line is not laid out should be set as nearly as possible 6 inches inside of the line which the curb will follow, so that when the street is afterwards laid out and curbed, the poles need not be shifted.

**21. Pole Setting.** Poles shall be set in the ground to a depth not less than that given in the following table.

TABLE 110 POLE SETTINGS		
Length Over All in Feet	Depth in Ground	
	Straight Lines	Curves, Corners and Points of Extra Strain
30	5.0 feet	6.0 feet
35	5.5 "	6.0 "
40	6.0 "	6.5 "
45	6.5 "	7.0 "
50	6.5 "	7.0 "
55	7.0 "	7.5 "
60	7.0 "	7.5 "
65	7.5 "	8.0 "
70	7.5 "	8.0 "
75	8.0 "	8.5 "
80	8.0 "	8.5 "

Sec. 10

LINE CONSTRUCTION

22. All holes shall be dug large enough to admit the pole without forcing and shall have the same diameter at the top as at the bottom.

23. Poles shall be set to stand perpendicularly when the line is completed. Exception can be taken to this rule, in that a very slight lean against the strain can be given to poles at line terminals, corners, curves and other points of excessive strain.

24. Poles with a bend or crook shall be so placed in a line that the defect is as unsightly as possible. In general, this result will be obtained by turning the pole bend in the same direction as that followed by the line.

25. After a pole is placed in position, only one shovel shall be used in filling the hole, while three tampers continuously pack in the filling until the hole is completely filled.

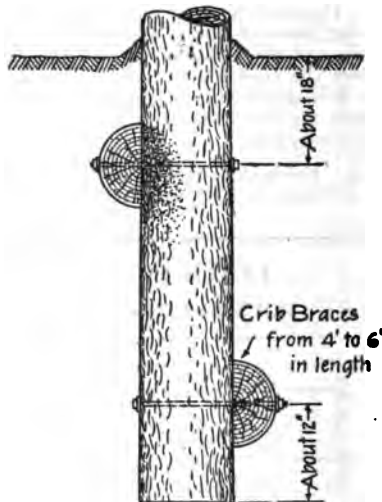

FIG. 368.—Crib bracing.

26. After the hole is completely filled, soil shall be piled up and packed firmly around the pole, and any sod which has been removed to set the pole shall be neatly replaced. New pole settings shall be inspected after they have been subjected to a heavy rainstorm, to make sure that the filling has not sunk and left around the pole a cavity dangerous to the public safety.

27. Crib Bracing. Poles which cannot be strongly guyed, and which must be set in soft ground, may be given additional stability

by crib bracing, as shown in Fig. 368. This consists of placing at the point of maximum strain two logs, about five feet long and not less than 8 inches in diameter. The top brace alone, or both braces, can be used according to the amount of additional stability required.

**28. Artificial Foundation.** When exceptional stability is required of a pole setting, an artificial foundation of concrete may be placed around the base of the pole. This concrete filling shall extend at least one foot from the pole on all sides, be carried above the ground line and bevelled to shed water, and shall consist of one part Portland cement, three parts sand and six parts broken stone or clean gravel, and mixed wet.

**29. Quicksand.** When poles are to be set in quicksand or in soft, muddy soil, where the digging is difficult and the setting insecure, the following method shall be used: As soon as a hole reaches a depth where the sides are continually caving in, place a barrel, without top or bottom, in the hole, digging down from inside of same, and driving down the barrel as the hole progresses. When the required depth has been reached, set the butt of the pole in the barrel, filling the latter with concrete and rock, as specified above for artificial foundation. If much of this work is encountered, the use of a special sheet-iron barrel constructed in two parts, so that the same can be moved from hole to hole, will expedite the work.

**30. Poles Located in Rock.** When poles are set in rock, the depth of setting may be decreased, depending upon the character of the rock.

**31. Protection.** Where the use of wood poles as hitching posts for horses cannot be avoided, the pole shall be protected by a substantial metal covering. Where poles are so placed as likely to be damaged by wagon wheels, they should be protected with hub guards.

### POLE STEPS

**32. Poles to be Stepped.** All poles carrying branch cutouts, incandescent lamps or other attachments that may require frequent attention, as also all testing poles, shall be stepped to facilitate climbing the same. For the same reason it will be found convenient to step poles carrying transformers.

**33. Galvanized Iron Pole Steps.** To fit steps to a pole, bore  $\frac{3}{8}$ -inch holes 4 inches into the pole in locations as hereinafter specified, and drive steps into these holes until they project only 6 inches from the pole, then with a wrench turn the steps so that the foot guard points upward.

**34. Location on Pole.** The location of pole steps on a pole is shown in Fig. 369. The lowest step shall be 7 feet 4 inches from the ground. It will be necessary to bore the pole with additional holes for steps at the locations specified in Fig. 369, so that linemen



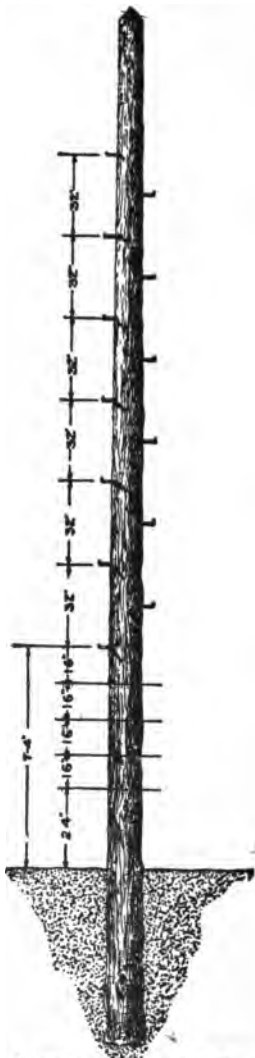

FIG. 369.—Location of steps on pole.

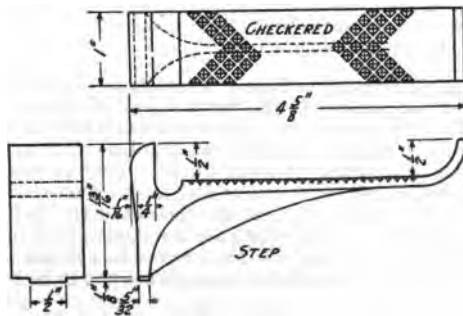
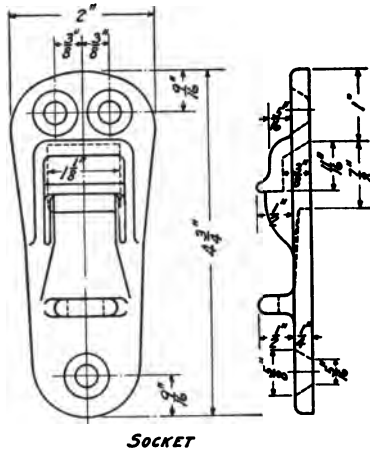
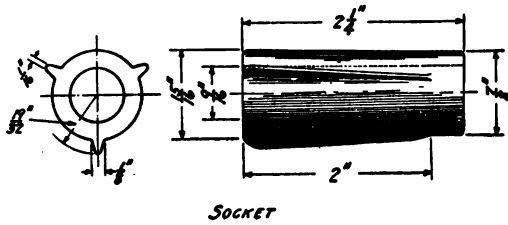

FIG. 370.—Two types of pole step sockets.

can insert small iron bolts or other form of portable pole steps when climbing the pole. These holes shall be equipped with pole-step sockets, as shown in Fig. 370.

35. Pole steps shall always be placed on a line with the street in which the pole is located.

### CROSS-ARMS

36. **Cross-arms.** Owing to the variations in dimensions and pin spacings of cross-arms now in use, it is difficult to specify crossarms that will suitably conform to, or completely cover, present practice. Whatever arm is used the spacing between the pole pins shall not be less than 20 inches, nor should the spacing between the side pins be less than  $10\frac{1}{2}$  inches. The arms covered by specification contained in Sec. 4, Art. 2, are recommended as satisfactory standards.

37. **Size Arms to Use.** It is recommended that the six-pin arm be adopted for general use. The four-pin arm shall only be used for single-arm suburban lines and for service buck arms. An eight-pin arm may be used for heavy pole lines, especially by companies having systems requiring four-wire distribution.

38. **Painting and Treating.** Cross-arms shall be seasoned for at least three months, and if not to receive a preservative treatment, shall be painted with two coats of standard white lead paint before leaving the yard. The use of cross-arms which have been properly treated with a suitable preservative is recommended, and the treatment should be as provided for in the specifications of the National Electric Light Association Committee on Preservative Treatment of Wood Poles and Cross-arms, (Sec. 9, Part II.)

39. **Cross-arm Bracing.** Before being placed on a pole, each cross-arm shall be fitted with two braces, the braces shall be attached to the front of the cross-arm by carriage bolts, which shall pass first through a washer, then through the cross-arm and then through the brace with the nut on the brace side.

40. **Fitting Cross-arm to Pole.** When possible, cross-arms shall be fastened to a pole before the latter is set. Each cross-arm shall be attached to the pole by one  $\frac{5}{8}$ -inch cross-arm bolt, driven through from the back of the pole. This cross-arm bolt shall be of sufficient length to pass completely through the pole and the cross-arm, and receive its complement of washers and nuts. One washer shall be placed under the head and one under the nut at the end of the bolt. Cross-arm bolts of a proper length for the thickness of the pole shall be used. The back of the pole shall never be cut out to allow the use of a shorter bolt, and projecting ends are not to be left on.

41. **Attaching Braces to Pole.** Each pair of cross-arm braces shall be attached to the pole by means of one  $3\frac{1}{2}$ -inch lag bolt.

42. Location of Cross-arms. Cross-arms shall invariably be placed either at right angles or parallel to the line of the street on which the pole is set. They shall always be faced on the opposite side of the pole from that on which the maximum strain comes. On straight lines where the spans between poles are equal the cross-arms shall be faced alternately on succeeding poles, first in one direction and then in the other.

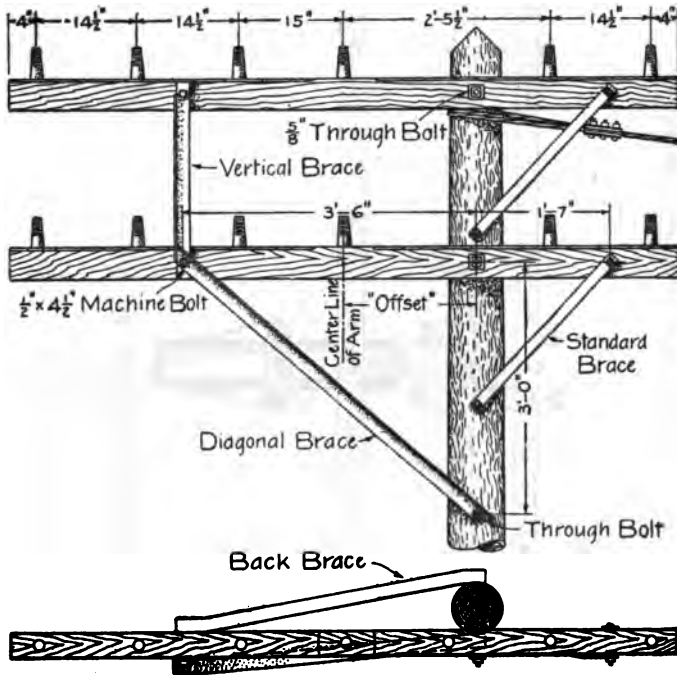

FIG. 371.—Side cross-arm bracing.

43. Side Cross-arms. It is sometimes necessary, in order to avoid obstructions, to use a side or offset arm. In such cases, a special arm of the same dimensions as the standard arm shall be used. This arm shall be bored for pins and bolt holes and installed with angle iron brace and back brace, as shown in Fig. 371. If the pole carries a heavy line, the unbalanced strain should be counteracted by side-guying or by ground braces, if the installation of side guys is impracticable.

**44. Double Arms.** At line terminals, corners, curves, where the line crosses over from one side of the street to the other and at points where there is an excessive or unbalanced strain on the cross-arms, pins and insulators, the pole should be doubled armed as illustrated in Fig. 372. Two blocks equal in length to the thickness of the pole between gains shall be placed between the arms,

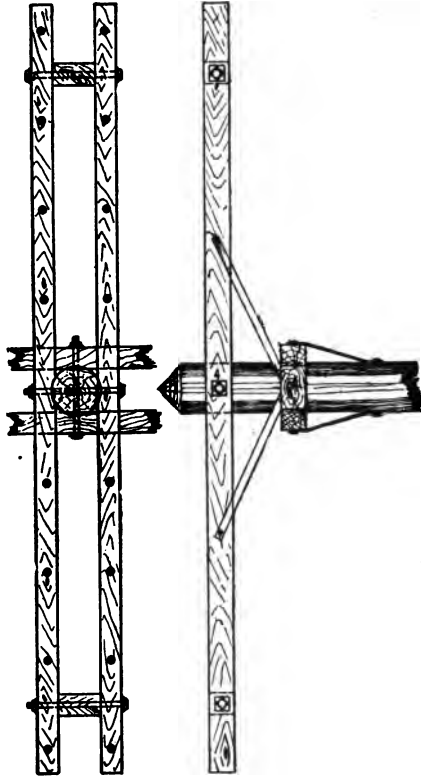

FIG. 372.—Double cross-arms.

one at each end between the two outside pins. An  $\frac{11}{16}$ -inch hole shall be bored at this point through the cross-arms and the intervening block. The two cross-arms shall then be bolted together by two  $\frac{5}{8}$ -inch bolts of proper length, passing through the cross-arms and the blocks, a washer being placed at both ends of each bolt.

In place of the wooden blocks, described above, spreader bolts may be used, as shown in Fig. 373. When a cross-arm guy is to be attached to the arm, an eye bolt may be substituted for the cross-arm bolt.

At line terminals the last pole shall be double-armed as specified, and the cross-arms of the last two poles before the terminal pole

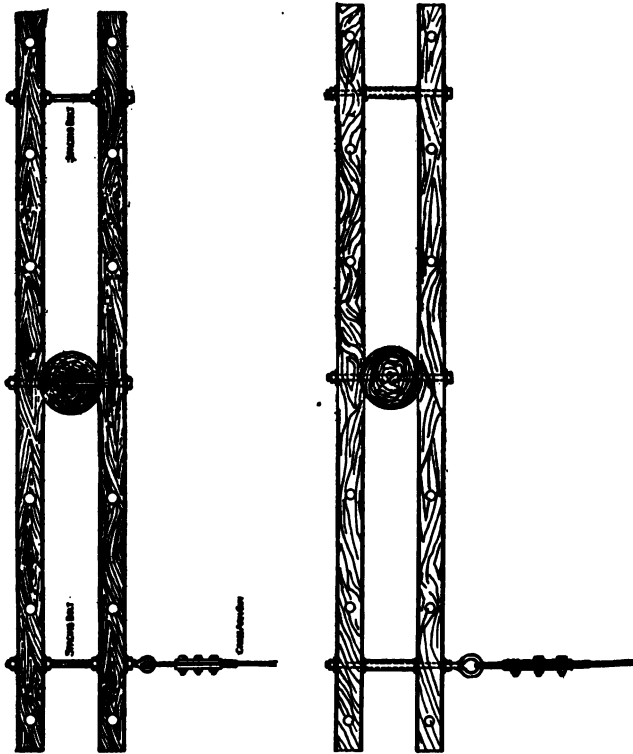

Fig. 373.—Double arms, using spreader bolts or pipe with a through bolt.

faced toward the latter. All poles on which two or more wires are dead ended shall be double-armed.

**45. Reverse or Buck Arms.** At corners, and where more than two wires branch from the main line, buck arms shall be used. A buck arm is a regulation cross-arm with fittings complete, set at

Sec. 10

LINE CONSTRUCTION

right angles to the line cross-arm, and 12 inches below it on centers, as previously specified for buck-arm gains. Judgment must be exercised in the use of buck arms, and ample room must be left for

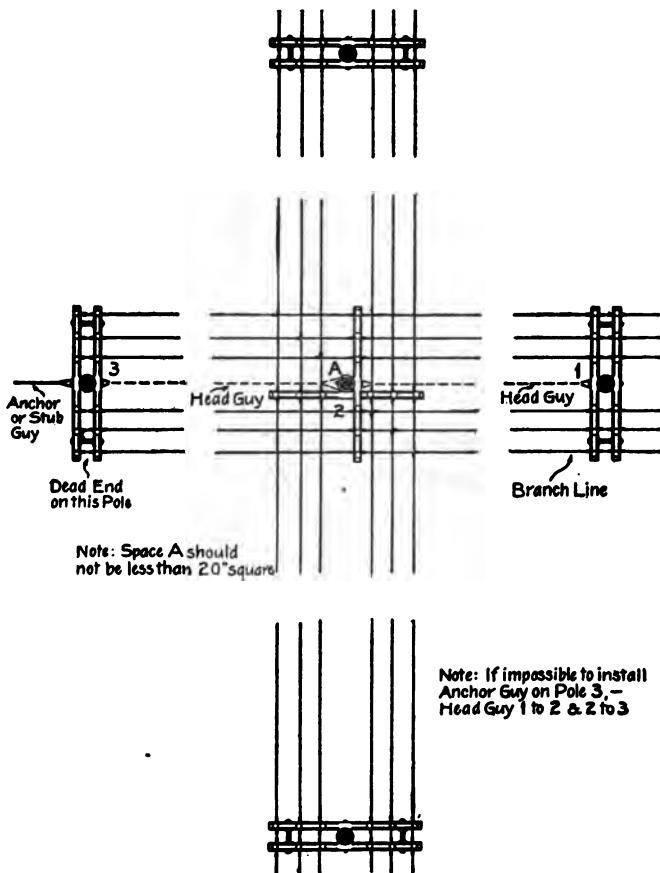

FIG. 374.—Junction pole without double arms.

climbing and working on the pole. In all buck-arm construction there shall be one clear space (neglecting the pole area) adjacent to the pole of at least 20 inches square. (Fig. 374.)

**46. Braces with Buck Arms.** On poles equipped with buck arms, the cross-arm braces shall be so attached to both the line arms and the buck arms as to permit their installation without interfering with the arms below. This can be accomplished by using a standard 28-inch brace, and attaching the same to the cross-arms at 23½ inches from the center of the arm, instead of 19 inches, which is the standard distance. The bolt holes in the arms for these braces will be special, and shall be bored in the field.

**47. Pins.** Before being taken from the yard, each cross-arm shall be fitted complete with pins. Pins shall fit tight into the holes in a cross-arm, and shall stand perpendicular to the cross-arm when fitted. Wooden pins shall be nailed to the cross-arm with one six-penny nail driven straight from the middle of the side of the cross-arm.

### INSULATORS

**48. Equipping.** Insulators shall be placed upon the cross-arm pins only when the wire is to be immediately attached thereto, and shall be screwed up tightly in every case.

**49.** If a wire be permanently removed from an insulator, and no other is to take its place, the insulator shall also be removed.

### POLE GUYING

**50. When to Use Guys.** Guys shall be used whenever they can be located, so as to counteract the strain of the wires attached to the pole and so prevent the same from being pulled from its proper position in the line. The following general instructions cover some of the special cases where guying is required.

**51. Straight-Line Guying.** Straight-line guying is for the purpose of giving additional stability to a line in case of severe storms. On pole lines carrying more than one cross-arm it is desirable to install guys on straight-line sections at approximately every twentieth pole. These storm guys shall consist of head guys extending from the top of the pole to the adjacent poles in the line on either side, and if possible, this same pole shall be side-guyed; that is, guys should extend from the top of the pole on either side at right angles to the line to guy stubs or other supports.

**52. Terminal Poles.** Line terminal poles should be head-guyed against the strain of the line and on heavy lines; that is, lines having three arms or more, the two poles next to the terminal pole shall be head-guyed in the same direction to assist the latter in taking the terminal strain.

**53. Long Spans.** In the case of exceptionally long spans, that is, spans exceeding 150 feet in length, the next adjacent poles on either side of the poles supporting the span shall be head-guyed against the strain, as shown in Fig. 375.



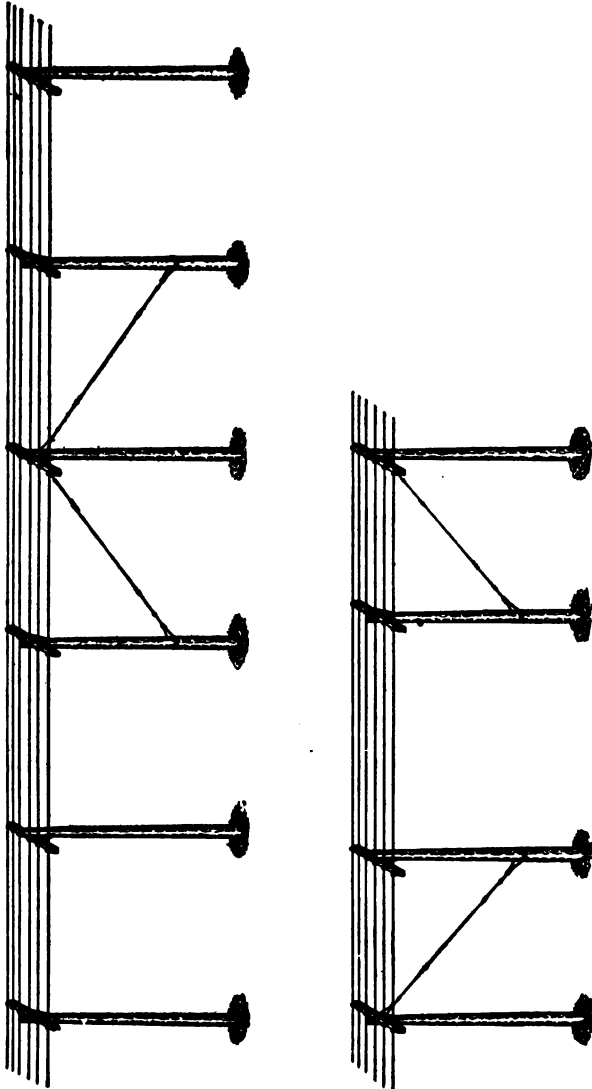

FIG. 375.—Head guys on straight lines and long spans.

54. **Corner Poles.** All corner poles, whether the turn is made on one pole or on two poles, shall be head- and side-guyed, as shown in Fig. 376.

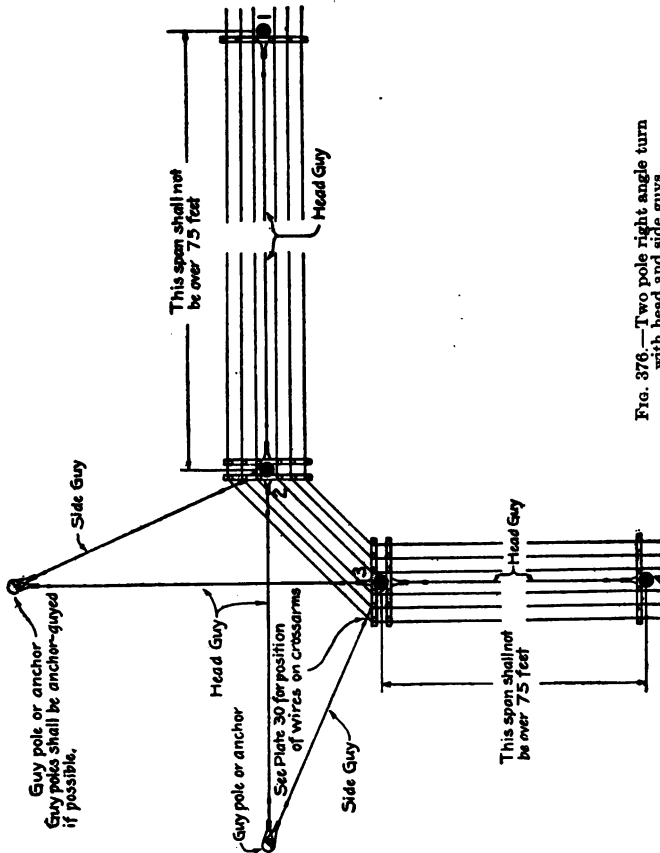
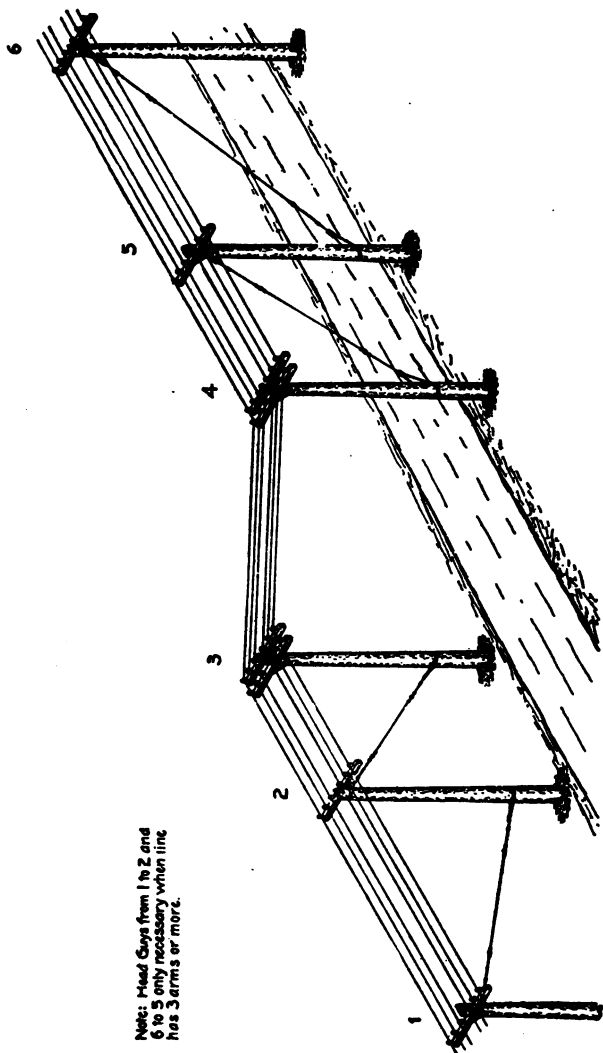

FIG. 376.—Two pole right angle turn with head and side guys.

55. **Curved Lines.** On curved lines, side guys shall be installed in line with the radius of the curve, and the pole spacing shall, if possible, be reduced. A convenient table for the location of side guys and for the spacing of poles on curves will be found in Fig. 367. In this table the word "pull" is a convenient expression for describing



Note: Head Guys from 1 to 2 and 6 to 5 only necessary when line has 3 arms or more.

FIG. 377.—Road crossing where impossible to use side guys.

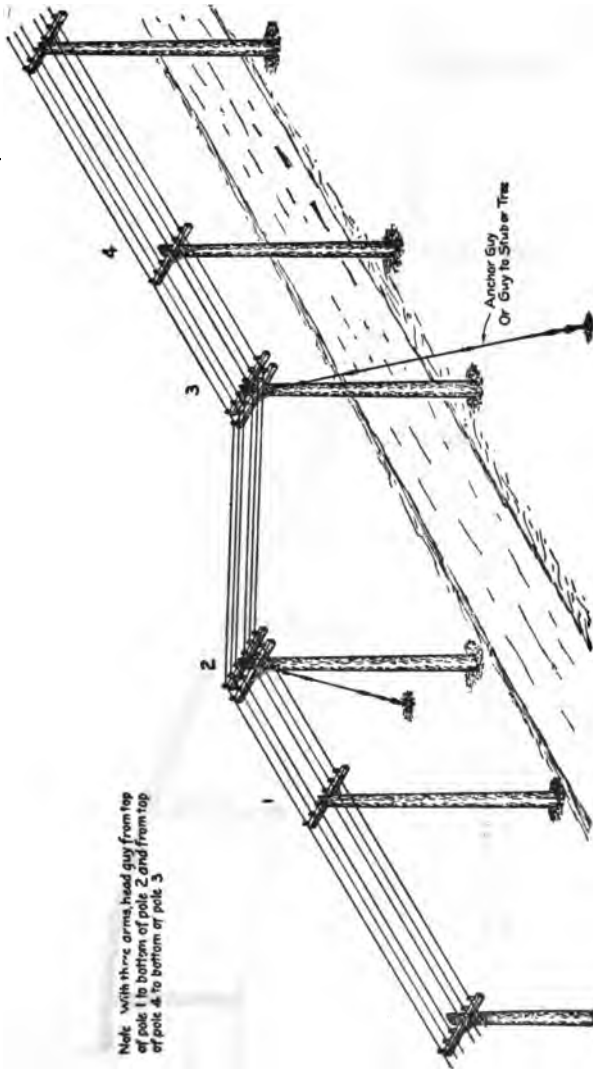
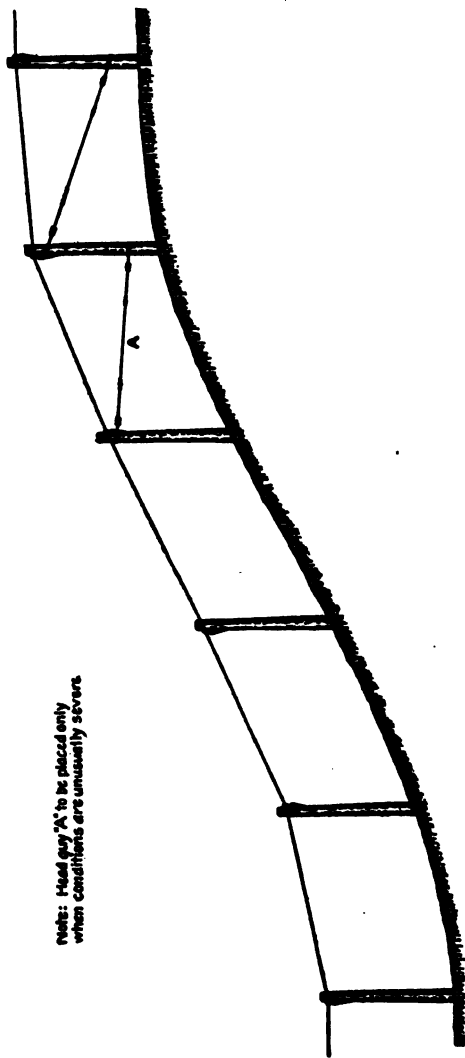

FIG. 378.—Road crossing with side guys.



Note: Head guy "A" to be placed only when conditions are unusually severe.

FIG. 379.—Head guying on hills.

the angle of deviation which the line makes at the pole, the amount of the pull being the distance from the pole to the straight line joining points on the line located 100 feet each side of the pole. All poles carrying two crossarms shall be side-guyed where the pull exceeds five feet. All poles carrying one crossarm shall be side-guyed where the pull exceeds ten feet.

**56. Poles on Hills.** Poles on steep hills shall be head-guyed to take the down-hill strain of the line on the poles.

**57.** Details of head- and side-guying are shown in Figs. 377, 378 and 379.

**58. Guy Wire.** The material used for guying shall be stranded cable, composed of galvanized steel wire in accordance with National Electric Light Association standard specifications. (Sec. 3.)

**59.** 2300-pound cable may be used for guying light lines; that is, for pole lines having not more than one crossarm and for guying crossarms.

**60.** 5000-pound cable shall be used for all regular pole guying.

**61. Guy Fitting.** In connection with stranded guy cable, galvanized iron guy clamps and thimbles shall be used.

**62. Guy Attachments.** All guy wires shall preferably be attached to poles, guy stubs, trees or other ungrounded supports, and when so attached shall not reach within eight feet of the ground. The reason for preferably attaching wires to ungrounded supports is for the purpose of insulating guys as thoroughly as possible from the ground, this protection being in addition to the insertion of strain insulators in the guy itself and having in view the protection of linemen working on a guyed pole from coming in contact with a grounded wire when working on live wires. It is also considered desirable to keep guys, where possible, at least eight feet from the ground, with the idea of keeping them out of reach of persons on the highway.

**63.** There will, however, be many cases in which it will be necessary to install guys where the conditions stated in Art. 62 cannot be complied with. In such cases, the guy wires may be attached to rocks, stone foundations, iron structures or other grounded supports, or anchor guys may be installed.

**64. Stub Guying.** When a line cannot be guyed by means of other poles in the vicinity, guy stubs may be set as shown in Figs. 380 and 381. Guy stubs shall be of wood and shall conform to the specifications covering the line poles. They shall be of sufficient length to insure the guys attached to them clearing roadways by not less than eighteen (18) feet, and footways by not less than twelve (12) feet, and also to insure that the guys attached to them shall clear electric wires by at least three feet, as specified in Art. 79.

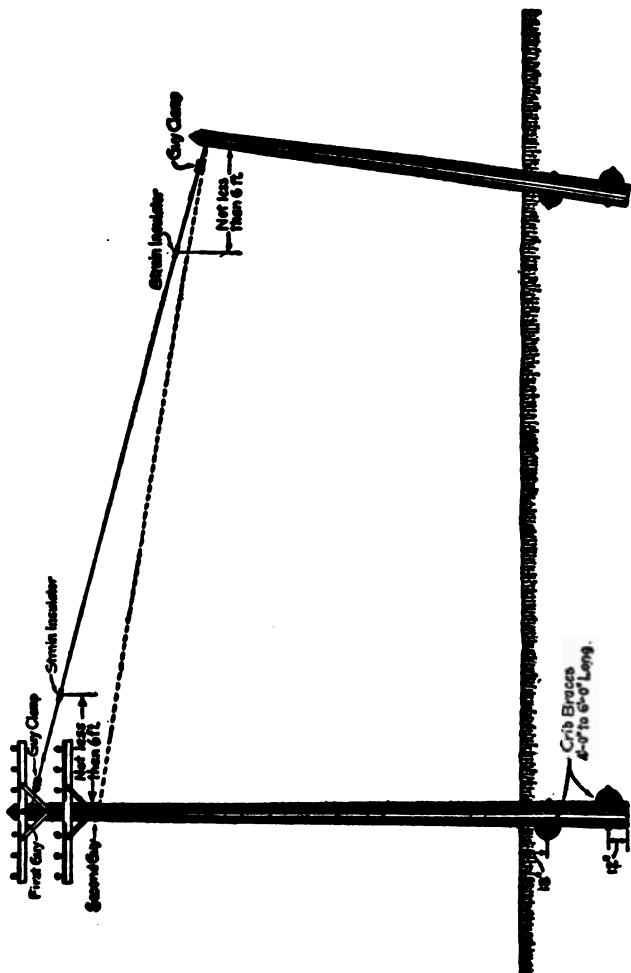

FIG. 380.—Guying to stub with crib bracing.

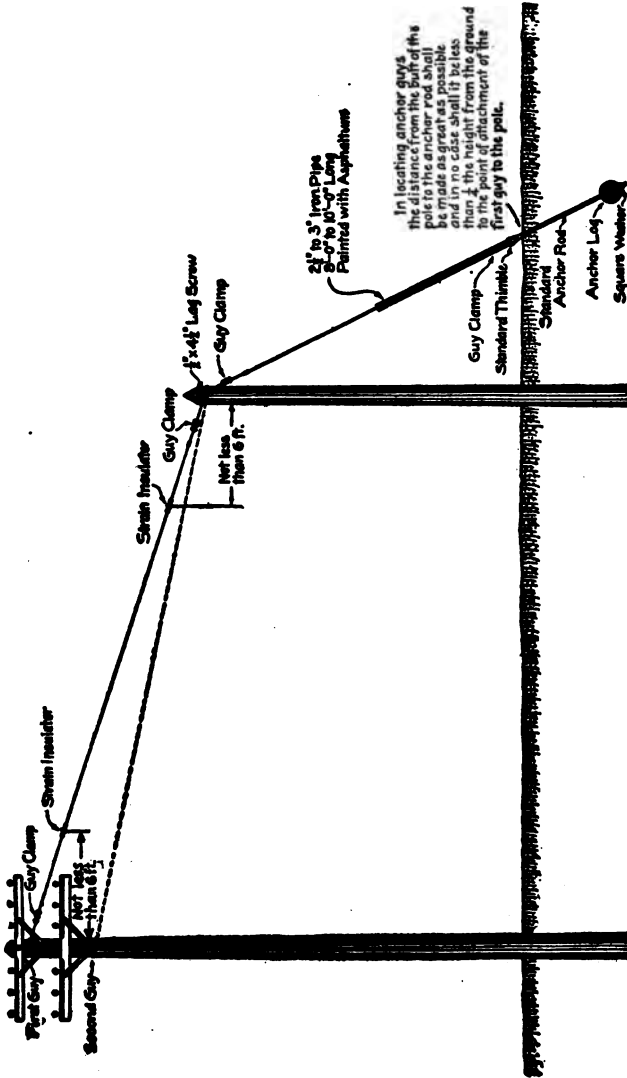

Fig. 381.—Guying to anchor guyed stub.



Sec. 10

LINE CONSTRUCTION

65. **Anchor Guys.** An anchor guy may be employed to guy poles, but must not be installed where it might interfere with surface traffic. It shall be constructed as shown in Fig. 382 and 383. This anchor shall be set in the ground so that the eye of the guy rod will

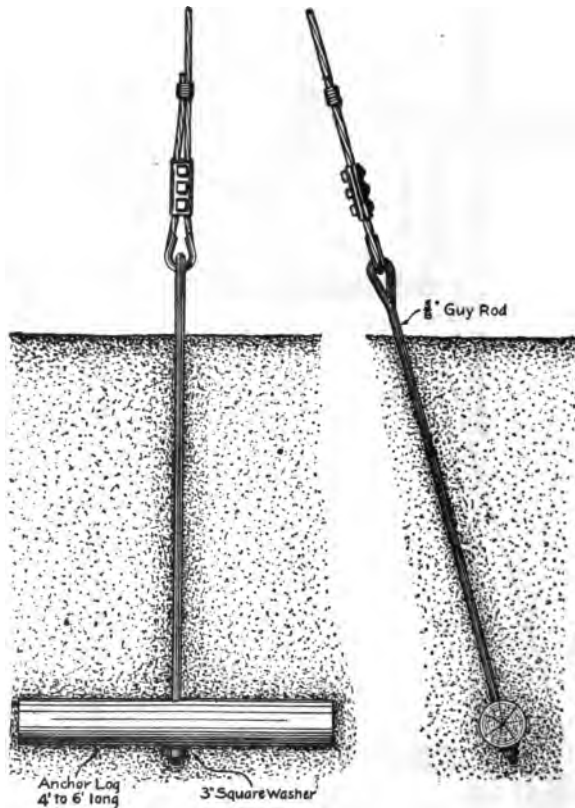

FIG. 382.—Anchor guy.

stand about one foot above the ground, the guy rod being in line with the guy wire attached thereto.

66. **Patented Guy Anchors.** As another method of attaching anchor guys, self-holding anchor rods may be used, of which several desirable forms are on the market. This method will be found

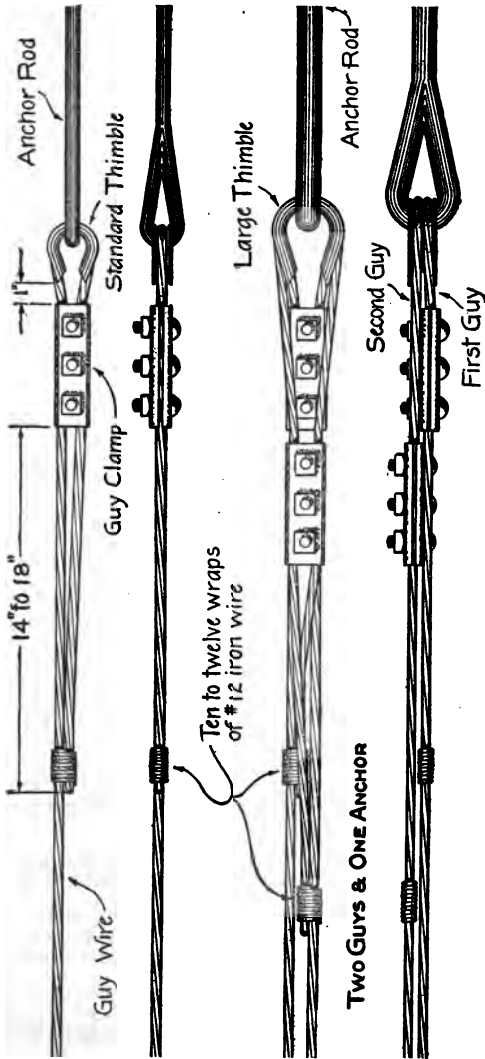

FIG. 383.—Methods of attachment of guys to anchor rods.

desirable in many places, particularly where the soil is of a sandy or loamy character.

**67. Guy-Anchor Protection.** Anchor guy wires that are so close to the street as to offer in any way an obstruction to traffic, should be protected with an anchor shield. This shield may consist of a 2½-inch or 3-inch pipe, installed as shown in Fig. 381. The anchor shield shall extend from the ground to a height of about eight feet.

**68. Locating Foot of Anchor Guy.** The guy anchor shall be so located that the angle between the guy and the pole shall be approximately 45 degrees, and in no case shall the distance from the foot of the pole to the foot of the guy be less than one-fourth of the height from the ground to the point of attachment of the guy on the pole.

**69. Tree Guying.** When guys cannot be conveniently attached to pole or guy stubs, trees may be used. Guy wires shall not be attached to trees without permission of the owner or other proper authorities.

**70. Tree guys shall preferably be attached to tree trunks.** When this is impossible, attachment may be made to a live, sound limb, close to the tree trunk, provided that the limb is not less than eight inches in diameter. In no case shall a guy be attached to a tree at a point where the swaying of the tree would affect the stability of the guyed pole.

**71. Tree trunks and limbs shall always be protected from injury by the use of tree blocks between the tree and the wire attached thereto.** Tree blocks shall be of chestnut and shall be placed around a tree trunk or limb sufficiently close together to prevent the wire from touching the same. To avoid injury to the tree, guy wires shall not be wrapped continuously around the same, but shall simply pass around the tree, supported on blocks, as shown in Figs. 384 and 385. To hold the blocks in place while the guy is being attached, a winding tape, or rope, is sometimes convenient.

**72. Method of Fastening Guys.** Guy wires shall be attached to poles and stubs by making two complete turns of the wire about the pole. The end of the wire shall then be clamped to the guy and the projecting end fastened thereto by a wrapping of galvanized iron wire, as shown in Fig. 386.

**73. Where a pole has one or two crossarms, the guy shall be attached directly below the top crossarm, as shown in Fig. 380.**

**74. Two Guys.** Where the pole has three or more crossarms, two guys may be attached, one directly below the top crossarm and the other directly below the third crossarm, as shown in Fig. 380.

**75. When two or more guy wires run to a pole or guy stub in close proximity to each other, the attachment of one guy shall never overlap that of another, but shall be entirely independent thereof.**

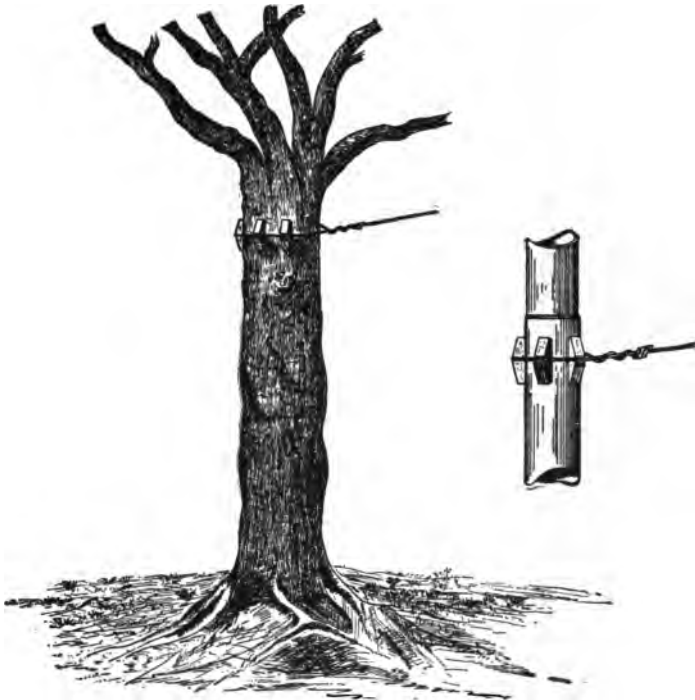

FIG. 384.—Guying to trees or iron poles.

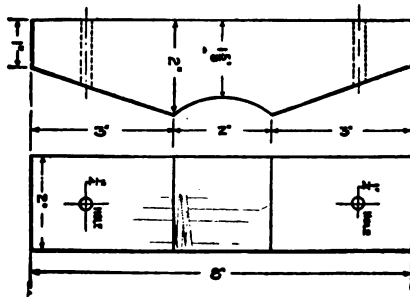
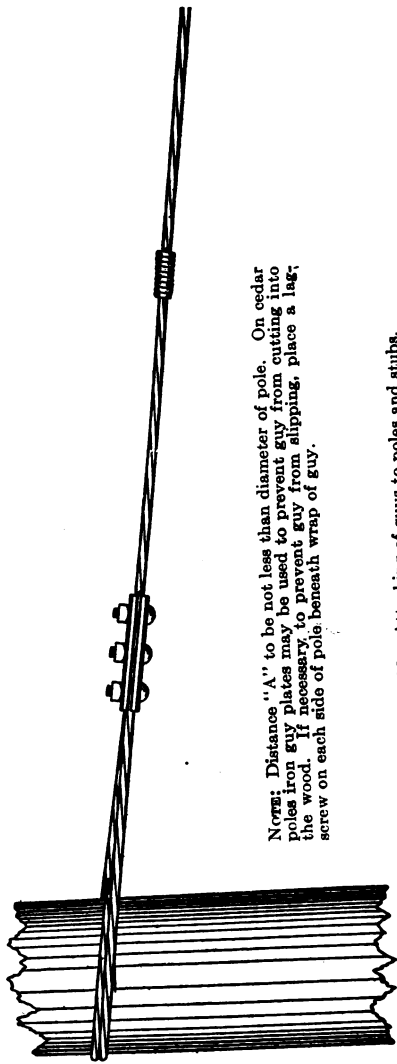
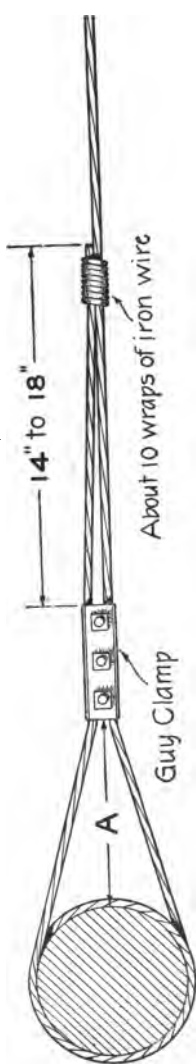

FIG. 385.—Standard tree block.



NOTE: Distance "A" to be not less than diameter of pole. On cedar poles iron guy plates may be used to prevent guy from cutting into the wood. If necessary to prevent guy from slipping, place a lag screw on each side of pole beneath wrap of guy.

FIG. 386.—Attaching of guys to poles and stubs.

76. When a pole is guyed with two or more guys pulling in approximately the same direction, a turnbuckle shall be installed in each guy to enable the strain to be equalized.

77. **Cross-arm Guys.** Wires must sometimes be attached to a cross-arm so that there is an unbalanced strain on one side of the arm, tending to twist it out of position on the pole. In such cases, the cross-arm shall be held in position by attaching the guy wire thereto, but it is advisable to limit, so far as possible, the use of cross-arm guys. Cross-arm guys shall, as a rule, extend back to the guy post independently of each other or of pole guys, as shown in Fig. 337. On light lines, however, it is sometimes advisable to combine two guys into one "Y" or bridle guy.

78. **Guy Before Running Wires.** In new construction work and in rebuilding old lines, guy wires shall be placed at points of excessive strain and the poles held in proper position before the lines are strung.

79. **Clearance.** Guys shall be attached to poles so as to interfere as little as possible with workmen climbing or working thereon. Every guy which passes either over or under any electric wires other than those attached to the guyed pole, shall be so placed and maintained as to provide a clearance of not less than three feet between the guy and such electric wires. As changes in temperature will effect the sag of the wires more than that of the guy, the latter being under strain, allowance must be made therefore at the time the guy is installed. For clearance of guys above ground, see Arts. 62 and 64.

80. **Iron Poles.** When it is necessary to attach a guy to an iron pole, tree blocks shall always be used between the iron pole and the guy wire to insulate the latter from the grounded iron pole, as shown in Fig. 334.

81. **Guy Insulation.** All guy wires attached to poles carrying electric light or power wires shall be insulated by the insertion of two strain insulators, the upper of these insulators being inserted in the guy so as to be at least six feet, in a horizontal direction, from the pole itself, or at least six feet below the lowest line wire, and the second strain insulator shall be inserted in the guy so as to be between six feet and eight feet from the lower end of the guy and at least eight feet from the ground. In short guys in which the two insulators here required would be located at the same point or near each other, the two insulators may be coupled in series and put into the guy together.

## WIRE AND WIRE STRINGING

82. **Wire Sizes.** For mains or feeders, wires shall be of copper, aluminum or copper covered steel, and no wire having a breaking strength less than No. 6 soft drawn copper shall be used. For service connections, No. 8 B. & S. gauge soft drawn copper wire may be used in spans up to and including 80 feet in length.

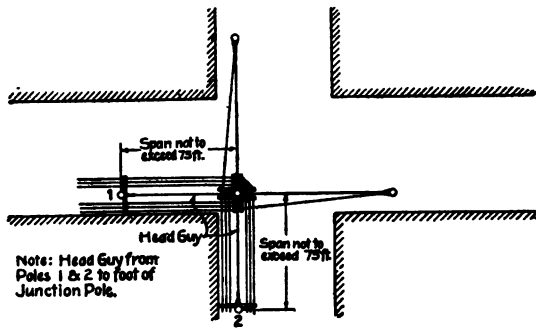
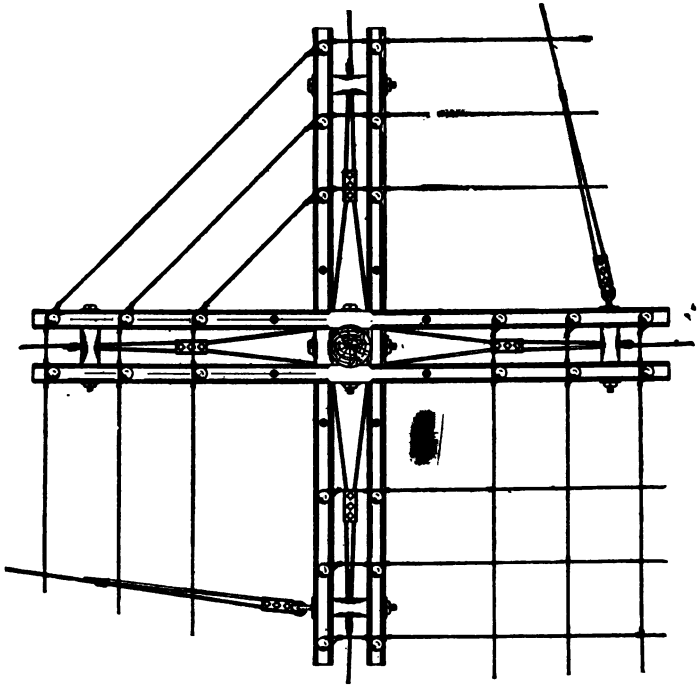

FIG. 387.—Cross-arm guying. One-pole method of turning corner.

Up to and including No. 00 B. & S. Gauge solid or stranded wire may be used. Stranded cable shall be used for all wire sizes larger than No. 00 B. & S. gauge. This rule does not necessarily apply to 500 volt trolley feeders.

Larger solid wires than No. 00 have sufficient strength, but are more difficult to handle and erect and therefore undesirable.

**83. Wire Insulation.** The standard insulation for line wires shall be a triple-braided, weatherproof covering.

**84. Support of Wires.** Line wire shall be carried upon standard insulators upon crossarms attached to poles. They shall not be carried on wooden bracket pins. Secondary wires may be carried on iron or steel secondary racks, when such racks are securely through-bolted to the pole.

**85. Wires Attached to Structures.** Primary or secondary wires shall not be supported upon trees. Primary lines shall not be attached to buildings if pole construction with proper clearance is practicable, but when absolutely necessary, primary wires may be attached to buildings by means of special construction. In designing this structure, ample clearance should be provided between the nearest primary wire and any projecting parts of the building, windows or fire escapes.

When primary wires must be carried into buildings other than central stations or sub-stations, connections should generally be made by means of cable running through-conduits.

**86.** When a high potential series circuit must be attached to a building in order to supply commercial series arc lighting therein, the wires must be installed in such a way as to be beyond the possibility of accidental contact by people in or about the place, and also so as to avoid possibility of contact with awnings, shutters, signs and similar fixtures on the building.

**87. Clearance.** The clear space between the crown of the road and wires crossing the same shall always conform to municipal ordinances or rules, but in no case shall such clear space be less than twenty-one feet. Similarly, the clear space between sidewalks and wires crossing them shall never be less than fifteen feet. The clearance over railroad crossings shall be 30 feet.

**88.** All guys crossing a roadway or footway shall be carried at an elevation of not less than eighteen feet above the crown of the roadway and not less than twelve feet above the footway.

**89.** The perpendicular distance between wires when attached to the same supporting structure should not be less than the standard spacing of the cross-arm gains, except where rigidly attached to the poles as when buck-arms or spreader brackets are used.

The perpendicular distance or clearance between secondary wires attached to the same pole line, where a vertical distribution system is used, may be materially decreased.



Sec. 10

LINE CONSTRUCTION

90. The perpendicular distance between wires crossing in the span shall be four feet.

91. Line wires shall clear all roofs so that they cannot be reached from the same, and they shall be so run that they cannot be readily reached from any portion of any other building or structure. If conditions require that they be attached to structures, as for example, in running under railroad or highway bridges, they shall be protected with sufficient insulation for the voltage carried, for the entire distance,

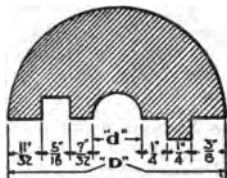

α AND β DEPEND ON SIZE OF WIRE



Fig. 388.—Abrasion moulding.

where attached to the structure, and to a point on either side of the structure that will be beyond the reach of anyone working thereon.

92. **Tree Trimming.** It is essential for the safe and uninterrupted operation of lines that they be free from possibility of grounding on trees. It is, therefore, important that tree branches interfering,

or likely to interfere, with the lines should be cut away. Such trimming must be done with care and judgment and under the immediate supervision of the superintendent, line foreman or other responsible person.

93. Before any trimming is done, the consent of the owner of the tree should be obtained. Opposition to tree trimming may sometimes be overcome by offering to employ a professional gardener for this purpose. If consent to trim trees cannot be obtained, and the interfering branches cannot be avoided by the use of longer crossarms or by offsetting the standard crossarms, tree wire shall be used, as specified in Art. 95.

94. Trees can generally be best trimmed in the Fall and Winter months when the leaves are off and the result of the work will be less noticeable. When branches have been cut off, they shall not be left to litter the streets, nor thrown into the nearest vacant lot, but shall be removed. The stubs of branches shall always be painted for their protection and to make them less noticeable.

95. **Running Through Trees.** When lines must be carried through trees that cannot be cleared or trimmed so as to give a clear passage for the wires, tree wire shall be used.

96. Sections of this approved tree wire shall be cut into the line, when running through trees. Weatherproof wire shall be used in those portions of the line clear of trees.

97. **Abrasion Moulding.** Where tree wire is used, if there is danger of limbs or large branches chafing the insulation, it shall be protected by means of wooden abrasion moulding. A satisfactory form of wood moulding is shown in detail in Fig. 388.

98. Before being placed on the line, the moulding shall be treated with one coat of P. & B. paint to increase the insulating qualities in the wood, the same being thoroughly dried before the moulding is used. The moulding shall be attached at its ends to the wires, as shown in Fig. 388, by three tight wraps of No. 12 copper wire around the moulding, and by similar wraps at intervals of not more than eighteen inches, if the strip is more than two feet long. The abrasion moulding shall be cut sufficiently long to avoid any chance of tree limbs ever catching under the end of same and ripping it off the wire or sliding it out of place. To fasten the moulding at the proper place on the line, wind tape tightly at each end, as shown in Fig. 388.

99. Wood abrasion moulding shall not be used on weather-proof wire carrying over 600 volts.

100. **Tree Insulators.** In some cases it will be found convenient, where wires are carried through trees, to use special tree insulators. The insulators used for this purpose shall be of a type that will hold the wires away from the limbs of the trees, but without re-

**Sec. 10**

**LINE CONSTRUCTION**

quiring that the wires should be rigidly attached to the insulators, the object being that there shall be sufficient play of the wire in the insulator to permit the swaying of the trees.

**101. Line Sag.** It is suggested that when pulling up lines by means of jack-straps, blocks and tackle, or other devices, the following sag or dip be allowed in a line of soft drawn copper wire:

<b>TABLE 111</b>							
<b>DIP IN ANNEALED COPPER LINE WIRE</b>							
Span in Feet.	DEFLECTION IN INCHES.						
	Temperature in Degrees Fahrenheit.						
	20	40	60	70	80	100	120
60	4	5	6	7	8	9	11
70	6	7	9	10	11	12	14
80	7	10	12	13	14	15	17
90	10	13	15	16	17	19	21
100	14	16	19	20	21	23	25
110	18	21	23	24	25	27	29
120	22	25	27	28	30	32	34
130	27	30	32	33	35	37	39

**102.** In running line wires, the wire shall be paid out from the coil by revolving the latter, in order to avoid twisting the wire. For this reason, wire coiled without reels shall be placed upon reels before being unwound.

**103. Tie Wires.** All tie wires shall have a surface of the same metal as that of the line wire in order to prevent corrosion.

They shall be dead soft so that when twisted up they will hold tight and not tend to spring loose. They must be strong enough to hold the line wire securely to the insulator.

On straight lines, all wires shall be tied on the pole side of the insulators with the exception of the wires on the pole pins, which shall be tied on the side of the insulator away from the pole as shown in Fig. 389. On straight line work the top groove of top groove insulators may be used instead. On curves and corners all wires shall be tied to the side groove of the insulator away from the strain, so that the insulator and not the tie wire shall take the strain of the wires, as shown in Fig. 389. No tie wires shall ever be replaced on a line after having been removed therefrom, as second-hand tie wires are hard and brittle and difficult to attach properly to the line. For ordinary strains use:

No. 6 tie for No. 6 line wire  
 No. 6 tie for No. 4 line wire  
 No. 4 tie for No. 2 line wire  
 No. 4 tie for No. 1 line wire  
 No. 2 tie for No. 00 and larger line wires.  
 Methods of tying are shown in Figs. 390 and 391.

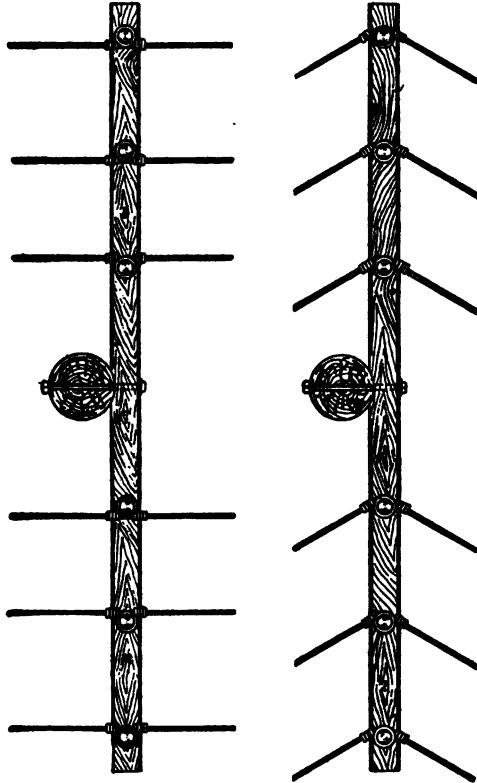

Fig. 389.—Location of wires on insulators.

**104. Splicing Wires.** Every joint and tap shall be carefully soldered and tapped. Mechanical connections shall be used on medium or hard-drawn copper wires.

**105.** The splicing of two pieces of line wire shall be so done as to be mechanically and electrically secure without the use of solder.

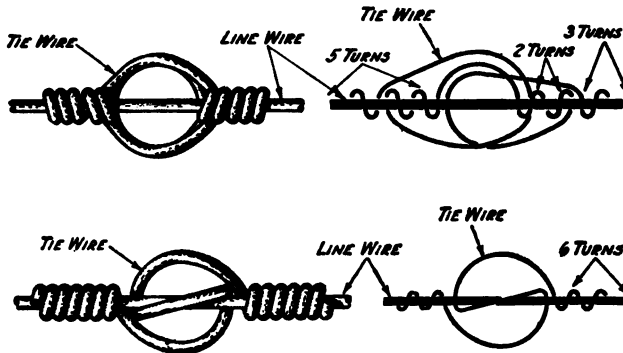
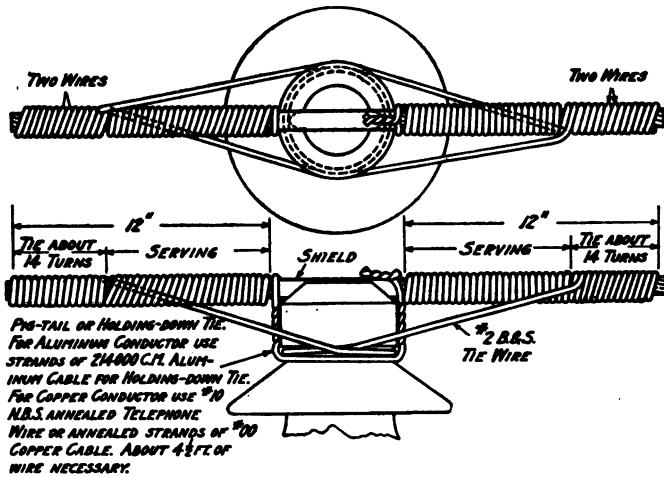

FIG. 390.—Ties.

Solid wire joints shall be made as shown in Fig. 392. The two ends to be spliced shall be scraped perfectly clean and free from insulation for the length necessary, then give one complete long wrap, followed by four complete close wraps about each other. The ends of the wrap shall then be cut close to the line wire and the entire joint thoroughly cleansed and well soldered with pure  $\frac{1}{2}$  and  $\frac{1}{2}$  solder. Wipe off soldered burrs from lower ends of joint and cover the

entire joint with standard tape. Give the same amount of insulation as that on the line wire. Tape wrappings will stick better to the joint if made while the latter is still hot from the application of solder.

106. Stranded cable splices shall be as shown in Fig. 393. Scrape perfectly clean and free from insulation a length of 20 inches to 24 inches at the end of the cables to be spliced. Spread the wires and pull each one straight, then cut out the core of each cable.

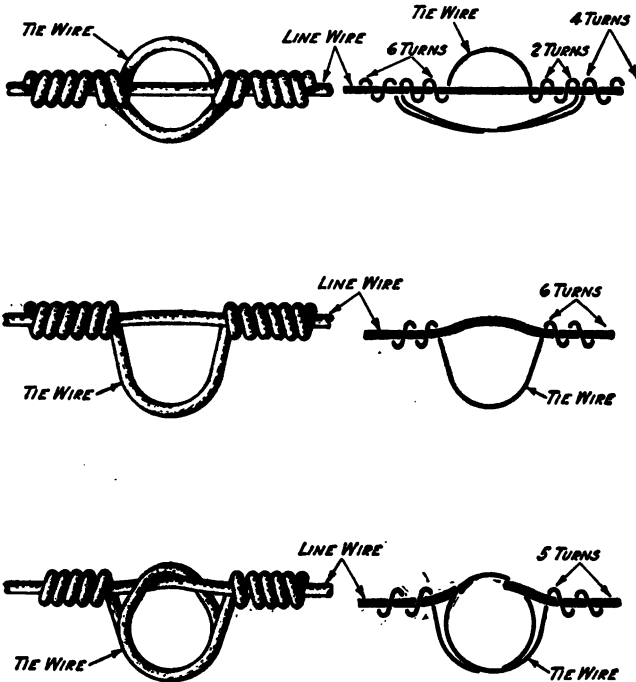

FIG. 391.—Ties.

Take the strand of each cable in groups of two wires each and alternately interweave them, laying all the ends closely along the cable. Then taking each group of two strands in turn, wrap them about the interwoven cables until all the ends have been wrapped. When completed, the joint should be about 9 inches long. Solder and tape as specified above.

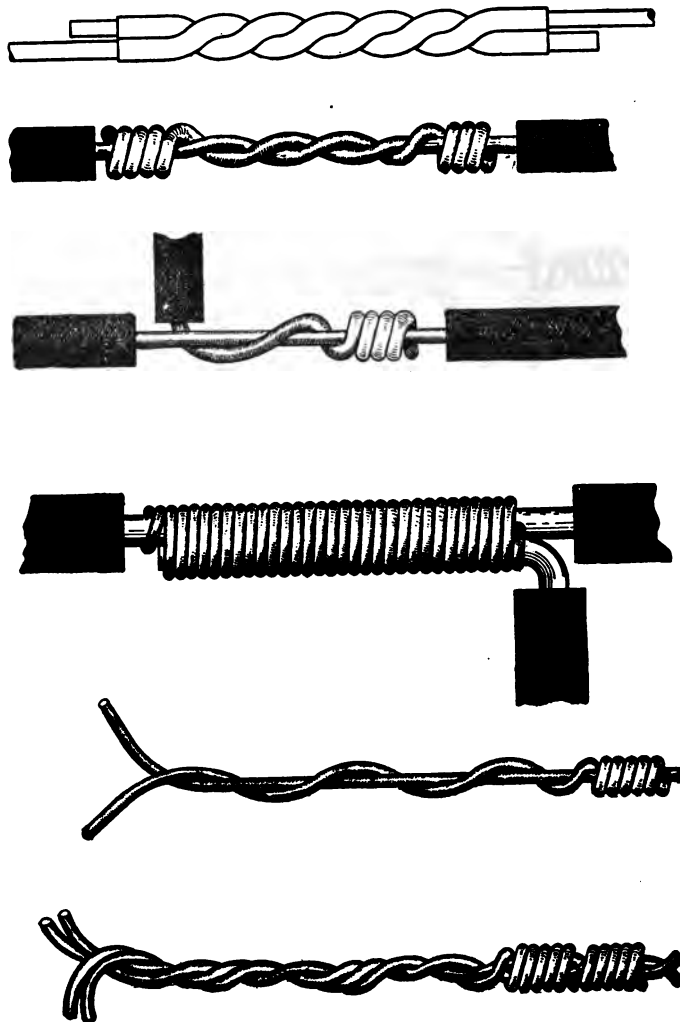

FIG. 392.—Solid wire splices and taps.

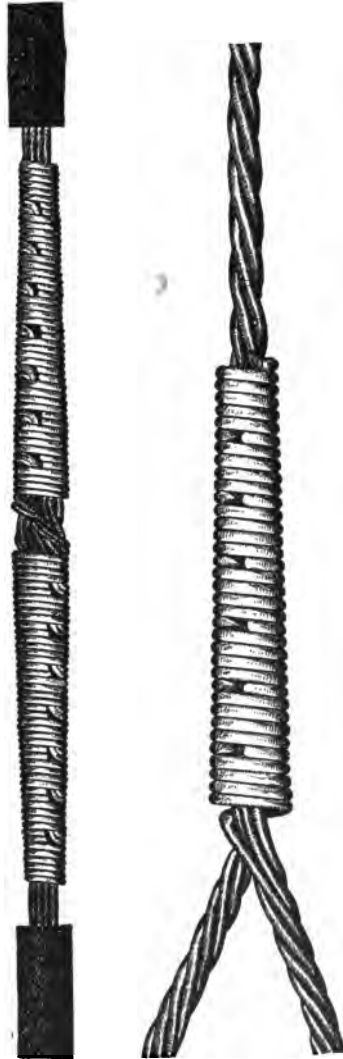

FIG. 393.—Stranded cable splice and tap.



**107. Taps.** A tap from a line shall be made in one of the two following methods: When the wires are small the tap shown in Fig. 392 third method, is the better. This tap is made by giving the branch wire one complete long wrap, followed by four complete close wraps, about the line wire. Solder and tape as specified above. For large solid wires and cables, the wrapped joint shown in Fig. 392, fourth method, may be used. The line wire and branch wires are scraped clean for lengths of about 4 inches, laid closely together and bound with No. 12 & B. S. bare copper wire. Solder and tape as specified above. A cable tap may be made as shown in Fig. 393.

**108. Branch Lines.** When only one or two wires branch from a pole, the tap may be made by the use of spreader brackets, as shown in Fig. 394. If the branch line carries more than two wires, a buck arm shall be used.

**109. Spreader Brackets.** Spreader brackets shall be fastened to the crossarms with four  $\frac{3}{8}$ -inch carriage bolts.

**110. Pole Wiring.** All taps and connecting wires passing from one level to another on a pole shall, so far as possible, be made vertical. All taps, branch wires and loops crossing from one side of a pole to the other shall cross the same horizontally. They shall also be made on one side of the pole only, namely, the cross-arm side, in order to keep the back of the pole free for climbing.

**111. Neat Work.** All bends in wires shall, if possible, be at right angles. When strung in position, all wires shall be entirely free from crooks and kinks and shall not hang loosely between supports. Loosely hung or kinked wires are not only unsightly, but are indicative of poor line work. Carrying wires across the face of a pole at right angles and necessarily without proper supports, not only increases the liability to trouble and makes trouble hunting and repair work difficult in the confusion of wires, but necessarily makes the wires an eyesore to the public.

**112. Line Terminals.** At line terminals the wires shall be dead ended on the back pin and firmly back tied on the front pin. To aid front pin in taking its share of the strain, the tie shall be put on the front pin as firmly as possible before the block and tackle used in pulling up the line wire is removed. A stranded cable dead end shall be soldered before the block and tackle or jack strap are removed.

**113. Corners.** At right-angle corners in heavy lines, when possible, turn by means of two poles as shown in Fig. 376. A corner with only one pole may be turned as shown in Fig. 387. The double arm may be omitted if necessary, to provide space for climbing. When guys will hold the pole securely, the line wires can be pulled tightly around the corner, but when guys are weak, the strain of the wire shall be correspondingly lightened.

**114. Dead Wires.** All wires temporarily out of service shall be left on the poles, but shall be cut dead, as their connection to a circuit carrying current only needlessly increases the chance of trouble on the lines. Wires permanently out of service shall be at once entirely removed from the poles.

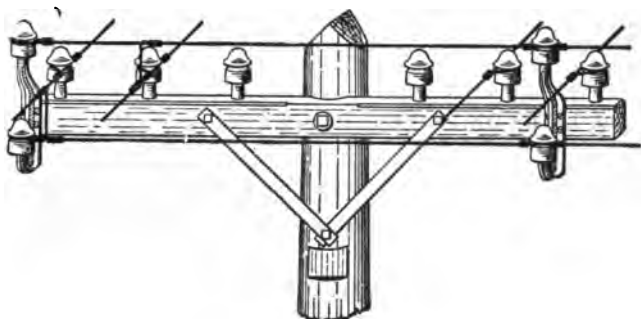
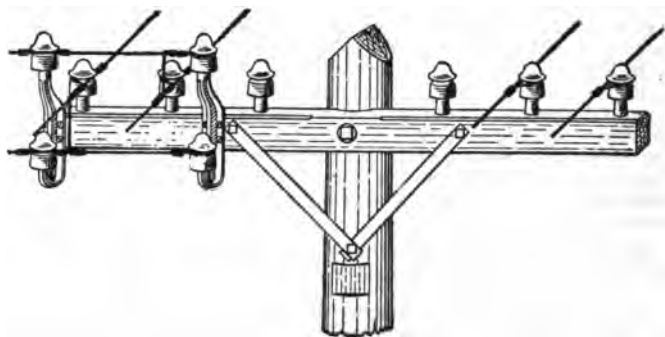

FIG. 304.—Branch tap line with spreader brackets.

**115. Reinforcing Wires.** When line or service wires become too small for their work and additional copper must be strung, the line shall not be reinforced by stringing additional wires on the same pins. Preferably, the old wires shall be removed from the line and

## Sec. 10

## LINE CONSTRUCTION

new wires of proper size strung in their places, thus keeping the actual number of wires on the line at a minimum.

**116. SYSTEMS OF DISTRIBUTION.** Commercial circuits shall be designed to furnish practically uniform voltage throughout a system of distribution. Otherwise, satisfactory lighting or power service cannot be supplied to consumers. To secure this end so far as possible, all constant potential circuits shall be laid out on the feeder and main system, feeders being run from the station or substation to some point of distribution centrally located in the district to be supplied. From this center of distribution the mains should radiate in such a manner and be of such a size that the drop in potential therein will be as uniform as possible, and as low as is warranted by the costs of construction. The drop of potential in the feeder between station or substation and the center of distribution, at time of maximum load, shall not exceed ten percent of the delivered voltage, this large drop being permissible only when separate feeder regulators are installed.

**117.** In general, consumers shall not be connected to feeders when they can be supplied from distributing mains or branches.

**118.** Branch lines or mains on the 500-volt power circuits shall be tied together as far as possible, thereby providing an interconnected network of wires throughout a district. Branch lines or mains, however, supplied by separate feeders, shall not be so interconnected.

**119. CARRYING CAPACITY.** The wires shall be of a size that the carrying capacity, as specified in Table, 24, Sec. 3, shall be amply sufficient for the load on each feeder, main or branch, reasonable allowance being made on new lines for increase in load due to future extensions of the business.

**120. LINES ON PRIVATE PROPERTY.** When lines or service connections are run upon private property, either by the company or by others, to connect to the lines of the company, whether paid for in whole or in part by the company or by the owner of the property, the construction work thereon shall be done in each case, and in every particular, in accordance with the standard line specifications.

## LOCATION OF WIRES

**121. Series Circuits.** Every series circuit shall start from station, substation, or other point of distribution, on a given pin and cross-arm, and shall follow this same relative pin and cross-arm throughout its course. Circuits shall not jump from one location on a cross-arm to another location on the same cross-arm, nor to a different cross-arm, but shall always be placed on their proper pin. Such a system of confining each circuit to a given pin throughout its course makes trouble hunting and repair work much simpler than they

otherwise would be and is the only possible way which circuits can be constructed, maintained, operated and extended in a satisfactorily systematic manner. As series arc and series incandescent circuits are cut dead during the daytime and will not, therefore, hamper linemen working on a pole, these circuits can often be run to advantage on the pole pins of the cross-arm. Such an arrangement is also convenient for making lamp loop connections. It should be noted that as it is the usual practice to ground all constant current series circuits in the station, that these wires should be considered as grounded wires by linemen when working on the poles, this in addition to the general rule that all wires shall be treated as being alive at all times.

**122. Multiple Circuits.** The wires of commercial circuits shall retain the same relative position on pins and cross-arms throughout their course and shall not jump from one set of pins to another set on the same cross-arm, nor from one cross-arm to another cross-arm.

**123. Locations on Pins.** The two wires of each circuit shall be run on adjacent pins of the crossarm, as these circuits are operated continuously day and night. 2300-volt circuits shall preferably be located on the adjacent pins at the ends of a cross-arm to keep line work as straightforward as possible; and to simplify street lamp, transformer and service connections, all through feeders shall be placed on the upper cross-arms of a trunk line as far as possible, and all circuits feeding the territory through which the line passes shall be located on the lower cross-arms. 500-volt wires can often be advantageously located on the pole pins at the center of a cross-arm.

**124. Temporary Work to be Avoided.** All construction and extension work on circuits shall be of a permanent character, both as to the routes followed and the quality of line work. Rush work, short cuts, skimmed materials and other such attempts to hasten the completion or reduce the initial cost of circuit extension shall be avoided. Temporary makeshifts in line construction necessitate frequent repairs and changes, are a continual source of trouble, interrupt service, annoy both company officials and consumers and, in the end, always cost more than permanently laid out, well-built lines.



# **SECTION 10**

---

## **PART II**

**SPECIFICATIONS COVERING METHODS OF OVER-  
HEAD LINE CONSTRUCTION FOR SECONDARY  
VOLTAGES, INCLUDING POLE WIRING  
FOR STREET-LIGHTING WORK.**

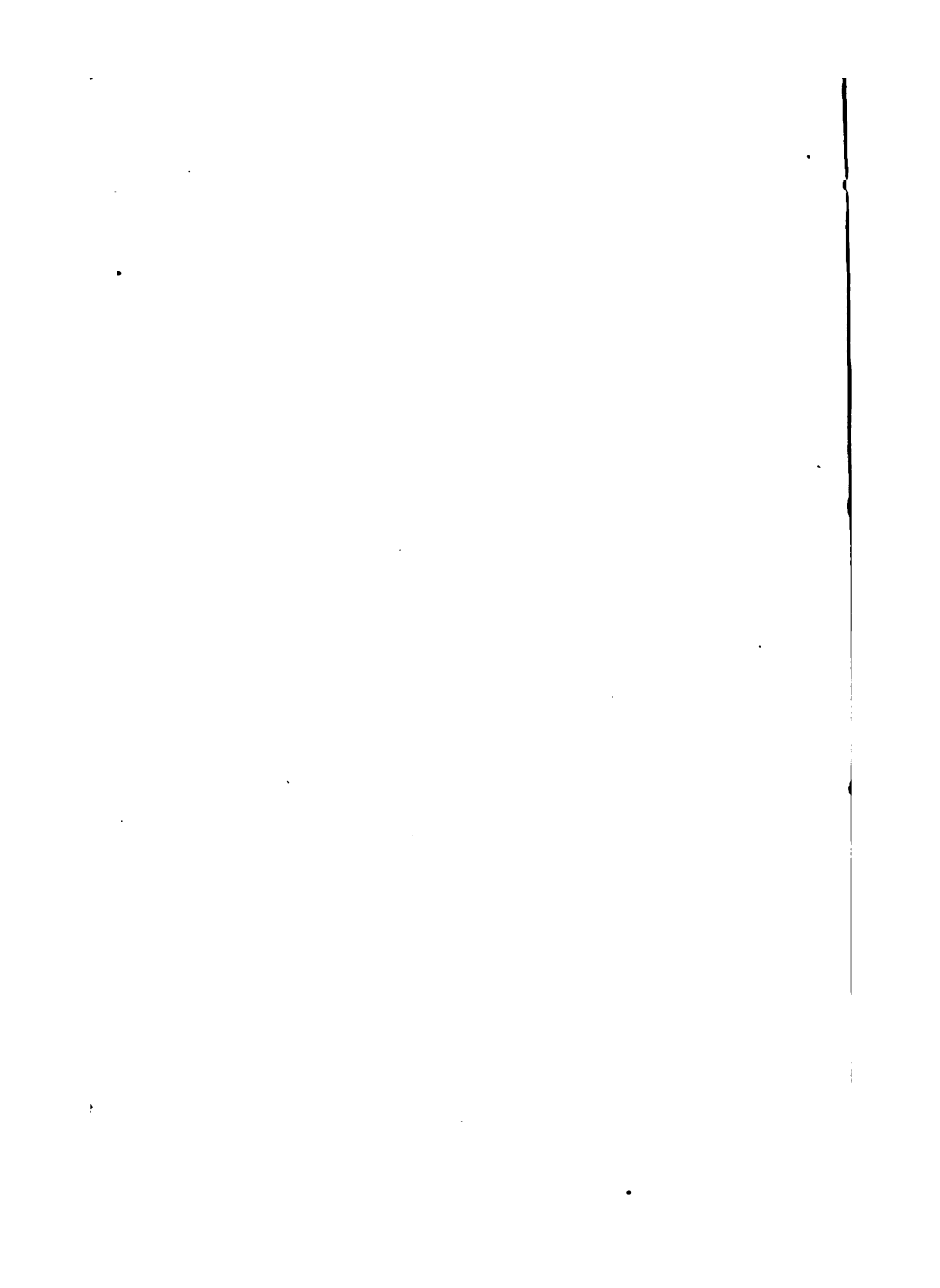

## SECTION 10

### PART II

#### SPECIFICATIONS COVERING METHODS OF OVERHEAD LINE CONSTRUCTION FOR SECONDARY VOLT- AGES, INCLUDING POLE WIRING FOR STREET-LIGHTING WORK.

---

#### TABLE OF CONTENTS

	ARTICLE
Stringing of Secondary Wires.....	1 to 7
Installations of Transformers, Fuse Blocks, etc.....	
When to use transformers individually.....	8 to 10
When to use more than one transformer.....	11 to 14
Method of Erection of Transformers.....	15 to 21
Fuse Blocks.....	22 to 29
Lightning Arresters.....	30 to 33
Consumers' Services.....	34 to 39
Pole Wiring for Street Arc Lamps.....	40-41
Pole Wiring for Street Incandescent Lamps.....	42-43



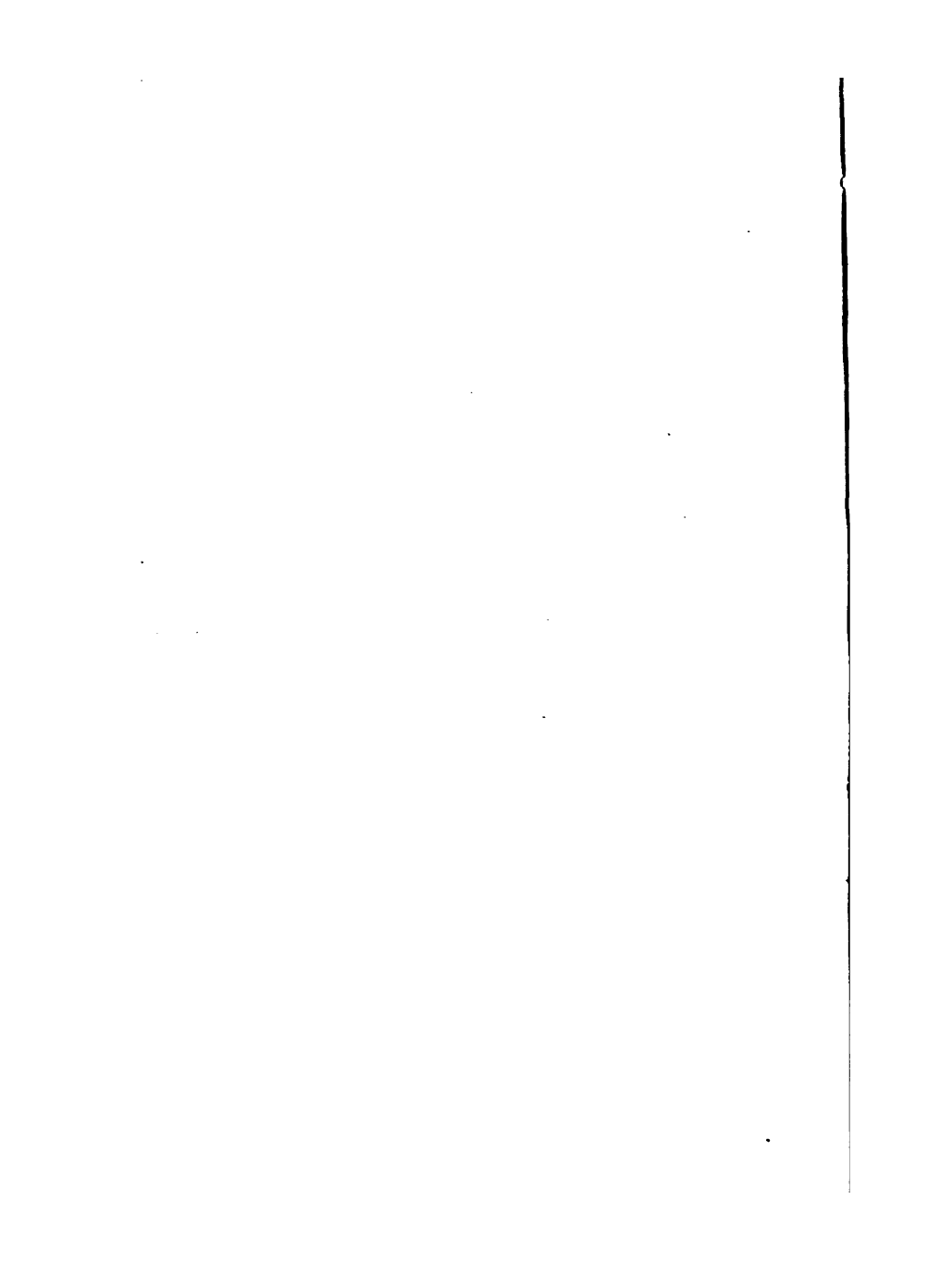

# **SPECIFICATIONS COVERING METHODS OF OVER- HEAD LINE CONSTRUCTION FOR SECONDARY VOLTAGES, INCLUDING POLE WIRING FOR STREET-LIGHTING WORK**

## **METHODS OF SECONDARY SYSTEM WORK**

### **STRINGING OF SECONDARY WIRES**

1. Secondary wires in all systems shall be located below the lowest arm carrying primary wires or series lighting wires.

2. Secondary wires of the same circuit, if carried on cross-arms shall be attached to adjacent pins. If secondary racks are used, Figs. 409 to 411, they shall be located below the lowest arm on the pole. The secondary wires shall be so located that the crossing of the pole will be avoided as much as possible; viz., on the side of the pole from which the greater number of consumers will be cut in.

3. When running single-phase, two-wire secondary mains, attached to cross-arms, the wires shall be placed on the two end pins on the side nearer the greater number of consumers.

4. When running single phase three wire secondary mains attached to cross-arms, the wires shall be placed on the three end pins with the neutral wire in the center.

When running single phase three wire secondary mains, on secondary racks, the neutral wire shall be in the top position.

5. When running two-phase, three-wire or four-wire, or three-phase, three-wire, secondary mains, the wires shall be placed in the same relative position as described for three-wire, single-phase work.

6. When running secondary mains where there is a probability of change to a system requiring additional wires, it is desirable to so locate the wires that vacant pins will be left, which will permit the running of the additional wires without disturbing existing wires.

7. 220-volt secondary mains shall not extend more than 600 feet in any direction from a transformer, although the secondary mains may be extended to a greater distance by banking transformers, when load conditions make it desirable.

## **INSTALLATION OF TRANSFORMERS, FUSE BLOCKS, ETC.**

### **When to Use Transformers Individually**

8. When consumers are too great a distance apart for the economical running of secondary mains, individual transformers shall be used.

9. Individual transformers shall also be used for large power loads and where the load is intermittent or of such a character as to interfere with the proper regulation of voltage on the secondary mains.

10. Loads which are likely to disturb voltage regulation will occur in installations of elevator motors, electrically operated cranes, welding machines, electrical furnaces, moving picture lamps, etc.

#### When to Use More Than One Transformer

11. It is desirable to use more than one transformer, connecting them in parallel, when the center of distribution on the section of the secondary main is changeable, due to the varying load conditions



FIG. 395.—Individual transformer installation.

of the individual consumers connected, although under such conditions the average maximum demand on the transformers will be comparatively constant.

12. In selecting transformers for parallel operation, it is desirable to have them of the same regulating characteristics, which can best be obtained by having them of the same make, type, form, etc., and, if possible, of the same size and series.

13. The limiting of the number of transformers to be used in a bank for multiple operation shall be determined by the relation of the load-factor of the individual consumer to the total load-factor of the bank of transformers, having in mind the difference in the



FIG. 396.—Individual transformer installation.

time of day of the maximum demand of the individual consumers connected to the bank.

14. The danger of putting too many consumers on one bank of transformers is that the service of all may be interrupted in case of accident to one or more transformers.

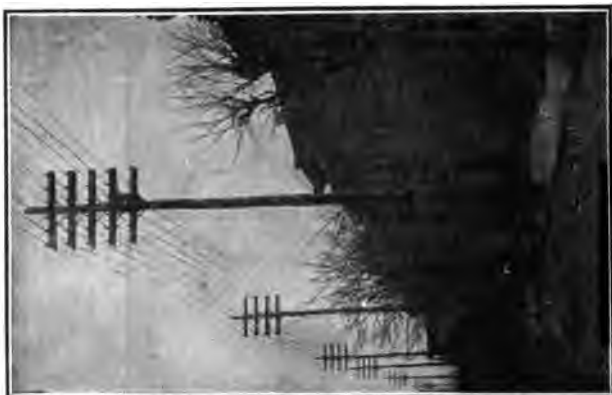

FIG. 398.—Individual transformer installation.

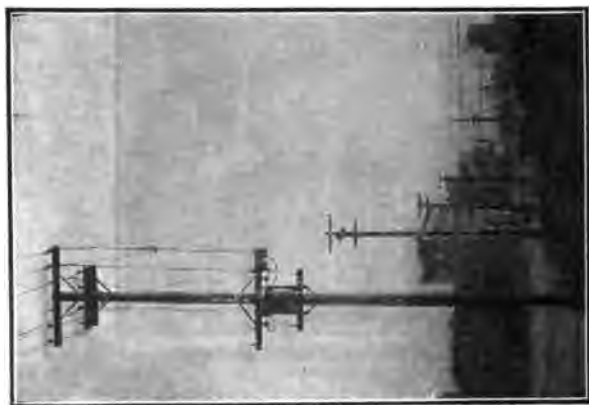

FIG. 397.—Individual transformer installation.

Transformers which are operated in parallel may be fed from a primary loop, so arranged that all the transformers connected in parallel can be disconnected by a single disconnecting switch or fuse block.

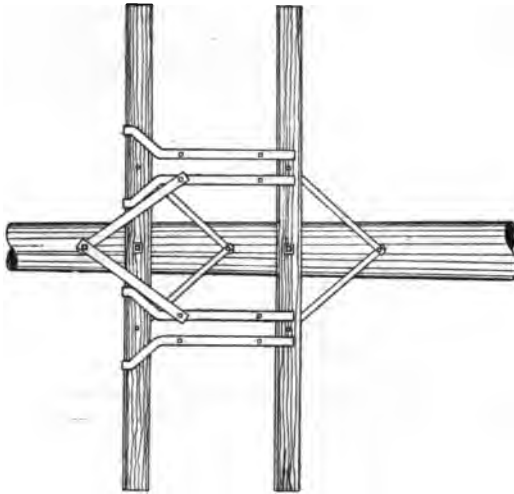

Fig. 400.—Special iron braces for two transformers.

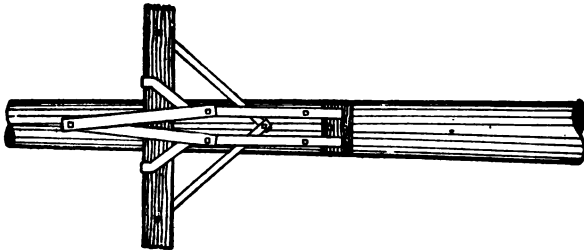

Fig. 399.—Special iron braces for individual transformer.

**Method of Erection of Transformers**

15. It is undesirable to erect more than one transformer on a pole, and the transformer shall be supported by suitable irons which pass over the cross-arm supporting the transformer. This arm may

be the top arm on the pole or the lowest primary arm on the pole when the transformer is fed from a circuit carried on the arm from which it is hung, or when high poles are used special transformer arms may be placed below the secondary arms, usually at a point midway between the top arm and the ground, but in any event, not lower than twenty feet from the ground.

16. Transformers shall be supported from the central point of the arm and not hung out on the arm away from the pole.

17. It is undesirable to hang from an arm transformers exceeding 25 kilowatts in capacity, and where such special cases occur, re-

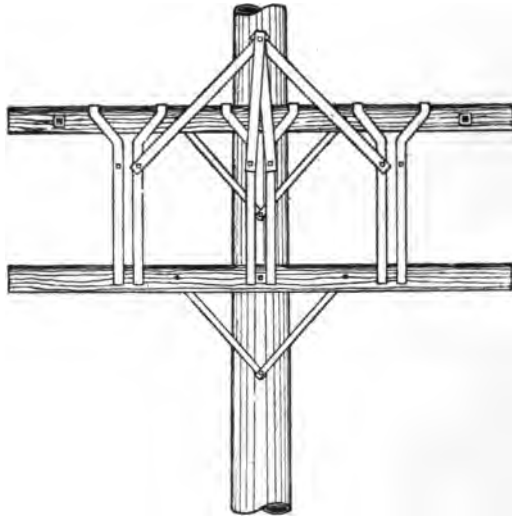

Fig. 401.—Special iron braces for three transformers.

quiring transformers in excess of this capacity, special supporting construction shall be installed.

18. Where special conditions make it necessary to hang more than one transformer on a pole, if the requirements do not exceed transformers of greater capacity than 10 kilowatts, they shall be hung on each side of, but near, the pole, and never placed back to back.

19. When special conditions require the installation of two transformers on a pole, each of a capacity greater than 10 kilowatts, they shall not be supported from the cross-arms on either side of the pole, as in the case of 10 kilowatts and under, but each large trans-

former shall be hung from separate cross-arms at the pole, thus placing the transformers, one above the other.

20. All wiring work in connection with the installation of transformers shall be done with not less than No. 6 double braid, rubber-covered wire.

21. All poles carrying transformers shall be double armed for the transformer work.

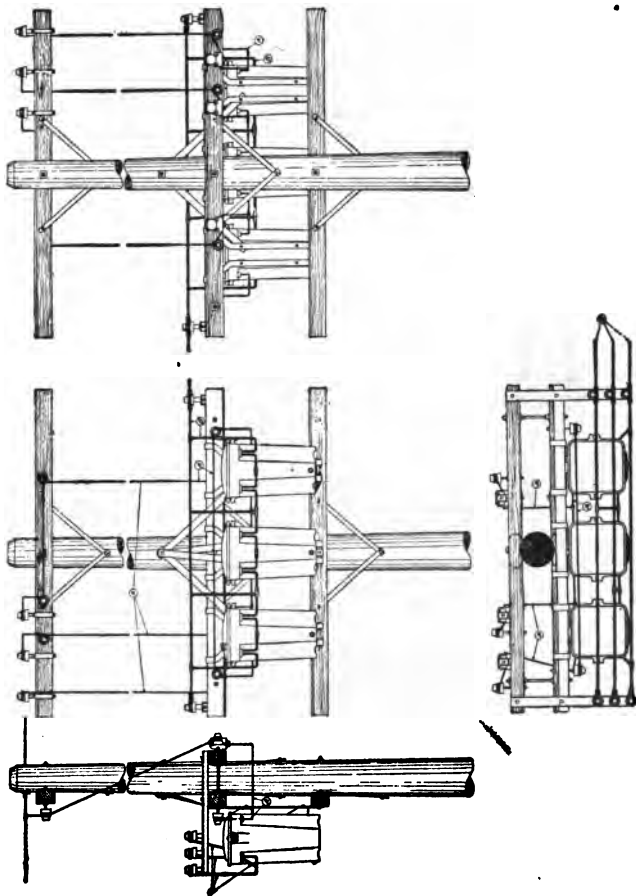

FIG. 402.—Wiring diagram of a three transformer installation.



## Fuse Blocks

22. To protect both the primary wire and the transformer, a single-pole fuse block, preferably of the porcelain variety, shall be inserted in each leg of the primary circuit when connection is made to transformer.

23. Fuse blocks may be placed at the head of all branch circuits, thus confining trouble on a branch circuit to the branch developing it.

24. Fuse blocks shall be located on the arm or on rear double arm from which the transformer is supported, and shall always be bolted to the crossarm by means of galvanized iron bolts not less than  $\frac{1}{2}$ -inch in diameter and usually approximately  $4\frac{1}{2}$  inches long.

25. Fuse blocks protecting transformers of three kilowatts capacity and over, shall be of a capacity equal to one ampere per kilowatt of

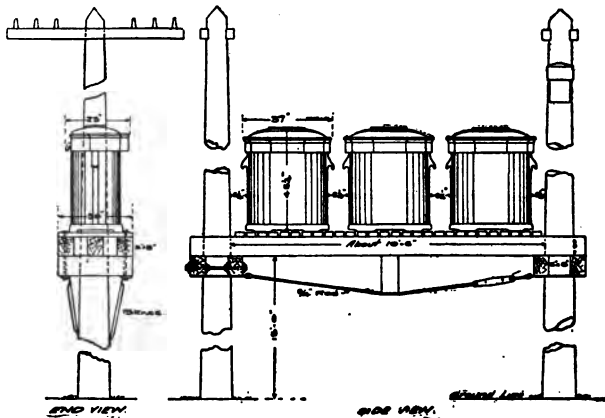

FIG. 403.—Special transformer rack.

the transformer protected, when primary voltage is approximately 2300 volts.

26. No fuse block shall have a smaller carrying capacity than one ampere.

27. Transformers from 0.6 kilowatt to 1.5 kilowatt capacity may be protected by a two-ampere fuse block, and transformers from two kilowatts to three kilowatts may be protected with a three-ampere fuse block; although it is also good practice to protect all transformers up to three kilowatts capacity with three-ampere fuse blocks.

28. The capacity of fuse blocks at the head of branch circuits will be determined by the load upon the branch circuit to be pro-

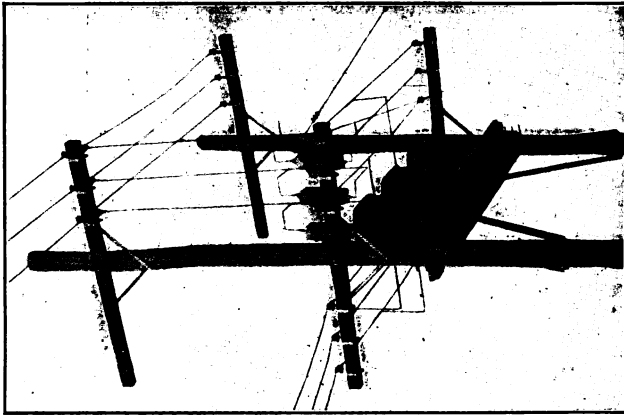

FIG. 406.—Installation of three transformers.

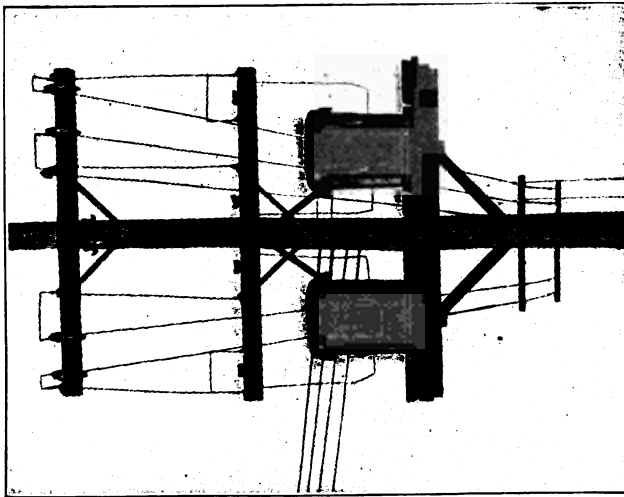

FIG. 404.—Installation of two transformers.



FIG. 406.—Special transformer rack.

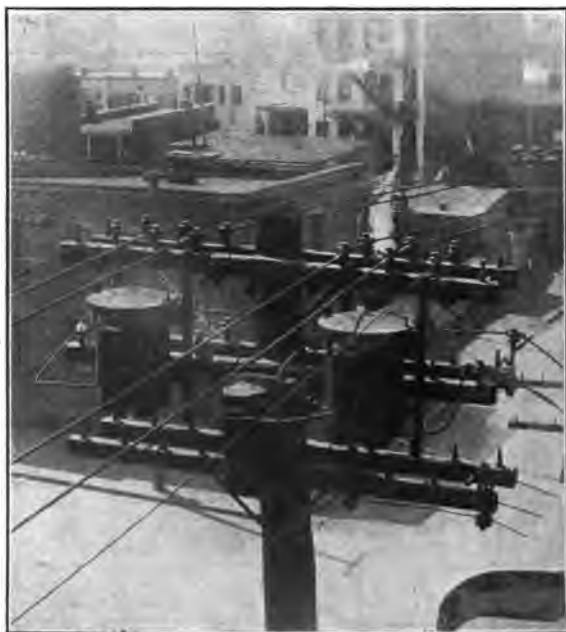

FIG. 407.—Installation of three transformers.

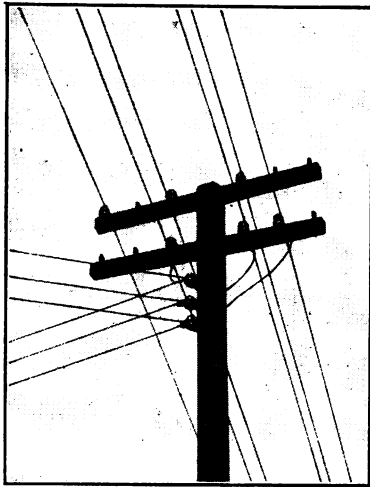

FIG. 408.—Vertical secondary distribution..

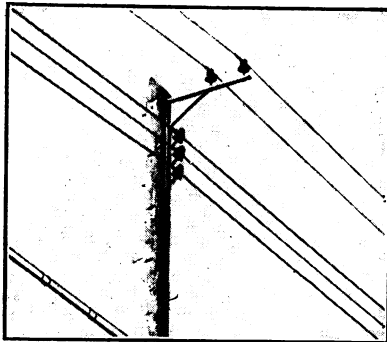

FIG. 409.—Vertical secondary distribution.

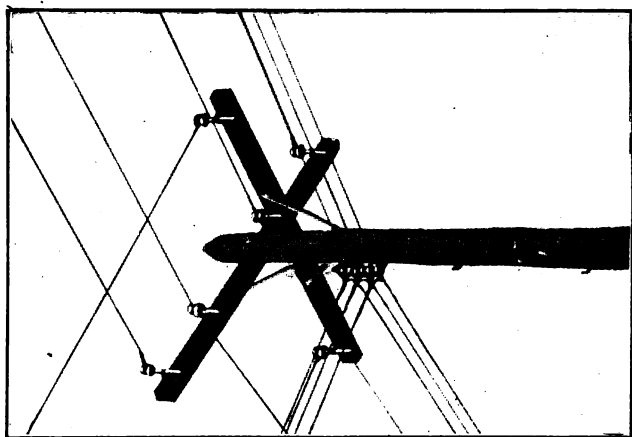

FIG. 411.—Vertical secondary distribution.

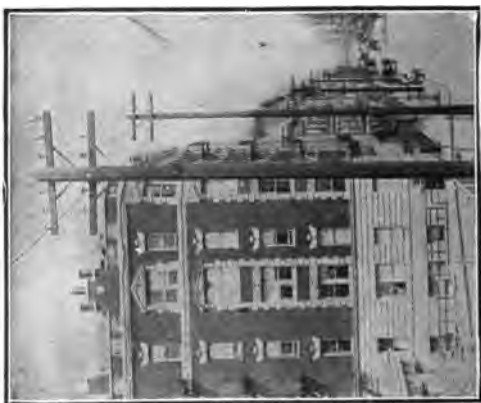

FIG. 410.—Secondary wires on consumers' side of pole.

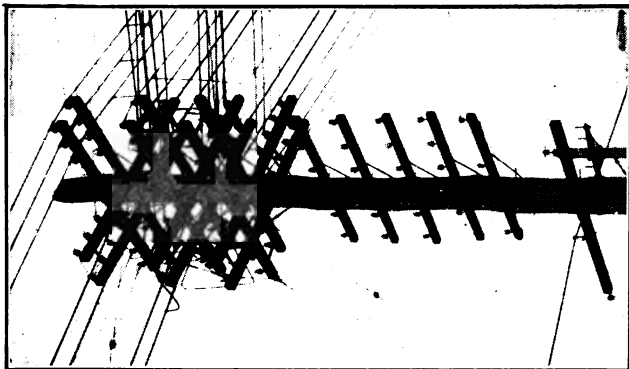

Fig. 413.—Junction pole.

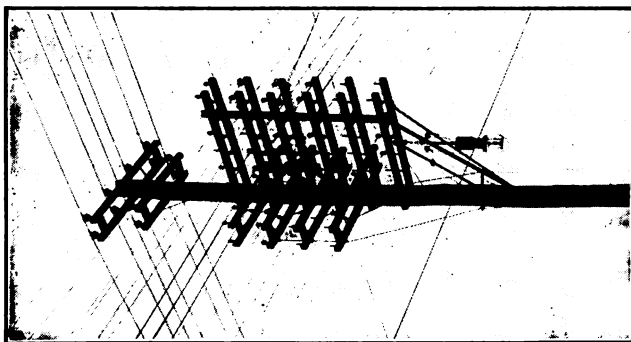

Fig. 412.—Junction pole.

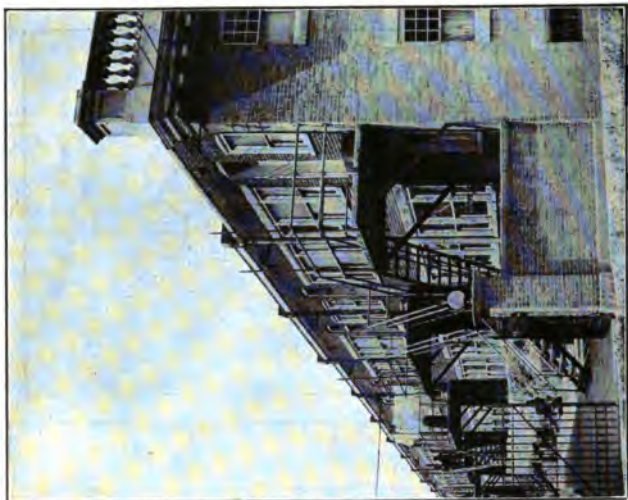

FIG. 415.—Consumers' service open wire.



FIG. 414.—Consumers' service open wire and duplex cable.



FIG. 417.—Consumers' service duplex cable.



FIG. 416.—Consumers' service open wires.



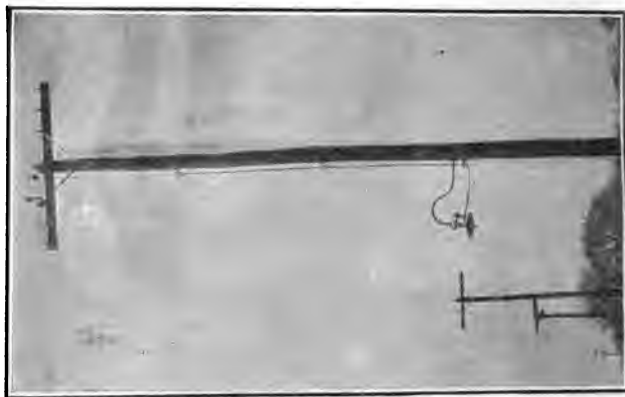

FIG. 419.—Duplex lamp lead to incandescent lamp.

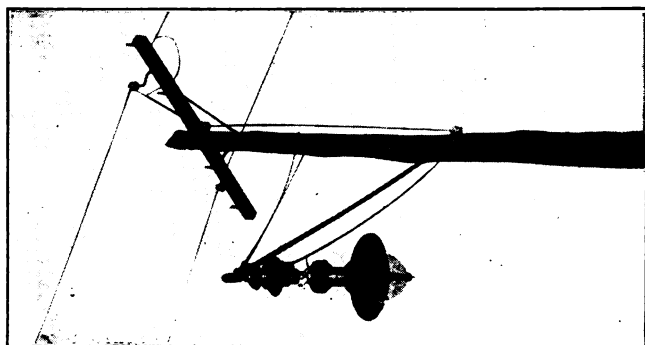

FIG. 418.—Arc lamp wiring duplex cable.

ected, but in no case shall fuse blocks so placed exceed seventy-five percent of the capacity of the station fuse.

29. All wiring work in connection with fuse-block installations shall be done with not less than No. 6 double braid, rubber-insulated wire.

### LIGHTNING ARRESTERS

30. Lightning arresters shall not be installed on poles carrying transformers, nor on poles at the head of branch lines, but shall preferably be placed on the pole next adjacent to the transformer or head branch-line pole.

31. Lightning arresters shall be bolted, not screwed, to the sides of the crossarms.

32. Ground connections for the arresters shall be carried down the pole, in a solid insulating conduit, in order to afford all possible protection to linemen working on the poles, as well as protection to the passer-by who might come in contact with the ground-wire covering.

33. Lightning arrester ground wires should never be run in metal pipes. For methods of grounding, see Sec. 6, Part II.

All wiring on poles in connection with the installation of lightning arresters shall be done with not less than No. 6 double braid rubber insulated wire.

### CONSUMERS' SERVICES

34. Service loops from a pole to a building may be made with suitable cable of more than one conductor, or with individual leads.

35. The use of cable makes a better looking job, as well as minimizes the number, and in many cases the size, of building attachments, but its use should be limited to loops not exceeding 100 feet in length, and should not be used in sizes of wire larger than No. 4, unless the service loops are very short.

36. The use of single-wire leads is desirable for long loops, for loops requiring large copper, and in installations where the additional cost of a cable is unwarranted, or where special physical conditions, such as interfering trees or structures, make cable work undesirable.

37. Overhead service wires or cables may be cut in from secondary systems by either one of three methods:

- 1st. By the use of buck arms.
- 2nd. By the use of spreader brackets.
- 3rd. By the use of secondary racks.

When the secondary system is run on crossarms, it is necessary to use either the first or second method. The second method, or the use of spreader brackets, is advised because of its more sightly appearance, and if used, the wires should be carried across the pole to the end of the arm, in such a manner that at all times they will clear all other wires by at least  $4\frac{1}{2}$  inches, and should be continued from the arm to the first point of attachment to the building or consumers service connection, in as direct a line as possible, making the run as nearly as practicable in a horizontal direction.

## Sec. 10

## LINE CONSTRUCTION

When the secondary system is carried on secondary racks, the overhead service wires or cables shall be cut in from the secondary rack in such a manner as to secure the proper fastening of the wires. Should it be necessary to cross the pole, a second secondary rack may be installed on the opposite side of the pole connecting both racks together, thus permitting the running of service connections in all directions in a workmanlike manner.

In order to balance the side strain on the poles from which service wires are run, guy wires should be installed, or effort should be made



FIG. 420.—Single wire incandescent lamp leads.

to so install service connections that the strain resulting therefrom is equalized.

38. All connections between the transformer and the outlets shall be properly spliced, soldered and taped, as described in Arts. 104 to 107, Sec. 10, Part I.

39. Underground service connections from overhead lines shall be run down the pole in a pipe, which from a point 10 feet above



FIG. 421.—Line entrance bushings. (Sub-station.)



FIG. 422.—Turning a 90° bend on two poles.

**Sec. 10**

**LINE CONSTRUCTION**

the ground to the cross-arm, shall be of a suitable insulating conduit, in order to afford all possible protection to linemen working on the pole.

**POLE WIRING FOR STREET ARC LAMPS**

40. The wiring from the cross-arm to an arc lamp shall be done with rubber-covered duplex cable and the same shall be rigidly

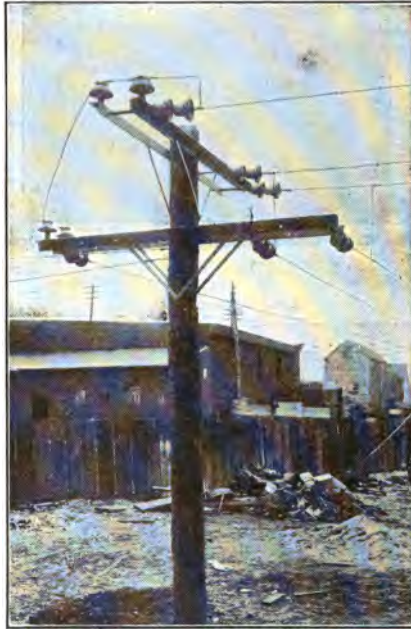

**FIG. 423.**—Turning a 90° bend on one pole.

supported on insulators attached to metal brackets so that the perpendicular run of the wire may be rigid and the wire will be held five inches from the pole throughout its run.

41. The portion of the cable looped from the pole to the lamp shall not exceed a length necessary to lower the lamp for trimming purposes without straining the cable.

**POLE WIRING FOR STREET INCANDESCENT LAMPS**

42. The wiring from a cross-arm to an incandescent lamp shall be done with rubber-covered duplex cable and the same shall be rigidly supported on insulators attached to metal brackets so that the perpendicular run of the wire may be rigid and the wire will be held five inches from the pole throughout its run.

43. The perpendicular run of the cable lead shall extend down the pole to a point opposite the point of support on the incandescent lamp fixture and the run from the pole to the fixture shall be parallel to the ground line and sufficiently tight to insure neat appearance of workmanship.



# **SECTION 11**

---

## **PART I**

### **METEOROLOGICAL AND GENERAL DATA**

---

## **PART II**

### **RULES FOR RESUSCITATION FROM ELECTRIC SHOCK**





## SECTION 11

### PART I—METEOROLOGICAL AND GENERAL DATA

#### TABLE OF CONTENTS

	ARTICLE
<b>Storm Movements</b>	
General.....	1
Weather Map Symbols.....	2
The Weather Map.....	3
Interpretation of the Weather Map.....	4
<b>The Thunderstorm</b> .....	5
Phenomena of Lightning.....	6
Causes of the Strong Uprushing Air Currents.....	7
Time and Localities Favoring Thunderstorms.....	8
<b>Rain</b> .....	9
<b>Snow</b> .....	10
<b>Hail</b> .....	11
<b>Ice Storms</b> .....	12
<b>Sleet</b> .....	13
Table 112.—Monthly Mean Maximum Temperature.*	
Table 113.—Monthly Mean Minimum Temperature.*	
Table 114.—Total Number of Days with Maximum Temperature 90° or above.*	
Table 115.—Total Number of Days with Minimum Temperature zero or below.*	
Table 116.—Highest Wind Velocities on Record with Direction.*	
Table 117.—Total Number of Days with Maximum Wind Velocity of 40 miles per hour or more.*	
Table 118.—Total Number of Thunderstorms.*	
Table 119.—Total Number of Days with Dense Fog.*	
Table 120.—Sleet Data.*	

\*Tables compiled from data furnished by the U. S. Dept. of Agriculture, Weather Bureau. Corrected to February 1st, 1914.

**Sec. 11**

**METEOROLOGICAL DATA**

	<b>ARTICLE</b>
<b>Discussion of Sleet Data</b> .....	14
Table 121.—Wind Velocity Correction Table.*	
<b>Corrections of Barometric Pressure</b> .....	15
Table 122.—Barometric Corrections.*	
<b>Hot Galvanizing</b> .....	16
<b>Sherardizing</b> .....	17
<b>Specification for Galvanizing Iron or Steel</b> .....	18
<b>Concrete</b> .....	19

---

\* Tables obtained from the U. S. Dept. of Agriculture, Weather Bureau.

The importance of meteorological data is not generally appreciated by lighting and power companies, particularly in sections and during seasons when transportation may be affected, or in localities subject to tornadoes, thunderstorms, sleet storms, etc. A compilation of data covering such phenomena has been secured through the co-operation of the United States Weather Bureau, Department of Agriculture, but inasmuch as these data are collected from observing stations, generally located in built-up sections of important cities, the official records do not necessarily indicate the maximum wind velocities, etc., which may be obtained in open country. They are of importance, however, in that they indicate the probable frequency of high winds, sleet storms, maximum and minimum temperatures, etc.

In addition to the above tabulation, a general description of storm movements and atmospheric phenomena, has been prepared by representatives of the Weather Bureau, which information is of particular importance in interpreting weather maps and other data issued by that Bureau.

### STORM MOVEMENTS\*

1. **General.** The Weather Bureau maintains something over 200 telegraphic observing stations which are distributed over the entire country. Observations are taken at these points every 12 hours and the results are transmitted by telegraph, in code form, to the Central Office in Washington, and are interchanged between all of the larger stations at which daily weather maps are published. So thoroughly has the telegraphic system been worked out that the entire distribution is ordinarily made in one-and-one-half hours, and in two hours after each observation the forecasters have mapped the atmospheric survey and are prepared to forecast probable movements and developments for 36 to 48 hours in advance. Such a system enables the forecaster to follow the storm movements closely, and to forecast for another state or a distant city with nearly as high a degree of accuracy as can be done for his own locality.

2. **Weather Map Symbols.** The locations of the observing stations are indicated by small circles. Where cloudiness prevails the whole area of the circle is blackened; for partly cloudy conditions, one-half of the circle is blackened; while the whole is left clear to represent clear skies. If rain is falling at the time of observation an "R" is marked in the circle, or an "S" for snow, as the case may be. Arrows are inscribed to note the direction of the wind.

The barometer reading, temperature, wind velocity in miles per hour, and the depth of precipitation (rain or snow), if any, are written by the side of each station in figures. The precipitation areas are outlined and shaded. Red lines are drawn through points

---

\*U. S. Dept. of Agriculture, Weather Bureau, Forecasting the Weather by Geo. S. Bliss.

of equal barometric readings, and indicate atmospheric disturbances. Blue lines are drawn through points of equal temperature and the completed chart is known as a weather map.

**3. The Weather Map.** The map illustrated (Fig. 424) has been selected because of its near approach to a theoretically ideal type illustrating the general laws applicable to atmospheric disturbances.

The isobars, or lines of equal barometer readings, form the most prominent feature of the map, as they locate the great centers of action. They are drawn for each tenth of an inch of variation. For example, the line, marked "30.0" at each end, passes through points where the barometer readings are just 30 inches. On one side of this line the readings are higher than 30 inches, and lines are drawn for each tenth of an inch increase until a center or crest is located and marked "High." On the other side, lines are drawn for each tenth of an inch decrease until the center of the depression is located and marked "Low." The isobars outline great atmospheric whirls or eddies.

It will be noted that the winds blow in toward the center of the area marked "Low," not directly, but spirally. Also that the winds rotate about the center in a direction opposite that of the hands of a watch face upward. Some places will be noted where the winds do not conform to the above rules, being temporarily deflected by local conditions. The more intense and energetic the disturbance becomes the more nearly will the wind movements conform to the general laws.

In the area marked "High" at the center it will be observed that the winds move in an opposite direction to those in the "Low." In other words, they blow spirally outward from the center. Also it will be observed that the air currents flow in a compound curve from the center of the "High" toward the center of the "Low."

Since the surface winds, as indicated by the arrows, blow in toward the center of the "Low" from all directions, it is evident that the air rises in the central area. Conversely, it is equally evident that the air is constantly settling down in the central area of the "High." The fact that the surface air currents flow from the center of the "High" toward the center of the "Low" suggests the idea that at some distance above the earth the rising air in the "Low" must flow toward the "High" and such is the case.

The interchange of air as noted above does not comprise the complete circulation of these areas, for if a map of a larger territory were prepared, it would indicate adjacent disturbances with which the same relations are maintained.

The temperature conditions attending such an atmospheric circulation are illustrated by the freezing line (drawn through points having a temperature of 32° F.) This line begins in the extreme northeast in central New Brunswick, and extends nearly due westward to a point north of the center of the "low," and thence sweeps southward nearly to the Texas coast, then northward into southern California, whence it bears northward nearly parallel

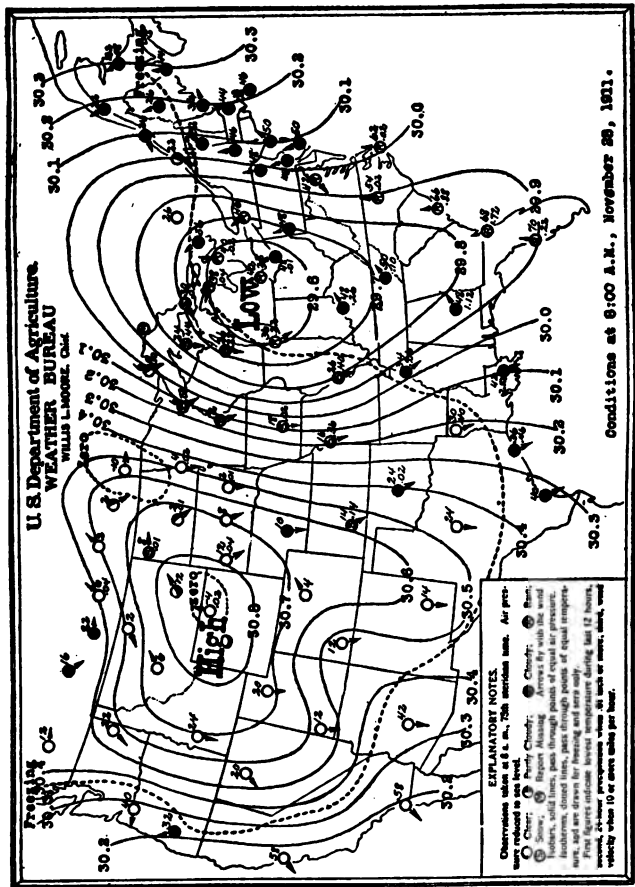

FIG. 424.—Typical weather map.

to the Pacific coast line. A study of the wind directions with relation to this line will suggest some of the reasons for its trend.

The weather conditions in these large atmospheric whirls are as remarkable as are the temperature conditions. Prevailing cloudiness is general in the low-pressure area. By way of contrast clear skies are general over the greater portion of the high-pressure area. Areas of high and low barometric pressure are constantly and successively drifting across the country from the west toward the east, thus causing the weather changes.

It becomes evident that while an area of low barometric pressure is drifting over a given locality the weather will ordinarily be cloudy with a tendency to rain or snow, depending on the season of the year. The temperature will at first be comparatively high, followed by colder when the center of the area has passed and the wind shifts to a westerly or northwesterly direction. As the area of low pressure passes eastward and is succeeded by an area of high pressure, the temperature will continue to fall for a time and the skies will clear.

A rapid succession of high and low pressure areas implies frequent changes in weather and temperature conditions, while conversely a sluggishness in the movements of these areas tends toward a prolongation of given types of weather.

**4. Interpretation of the Weather Map.** Many changes occur in the atmospheric disturbances during their progress across the country, owing to the continual shifting of their relative location with regard to mountains, lakes, the seashore, or to extensive dry plains. Barometric pressure areas are only formations through which the atmosphere circulates and they do not carry a given quantity of air with them across the continent.

Weather forecasting consists in watching the storm movements and developments by means of the weather maps, in anticipating the changes that will take place in them, in estimating the expanse of territory that will be covered and the time that given points will be reached thereby determining the weather conditions that may reasonably be expected in each locality during the ensuing 36 to 48 hours. A chart showing average storm tracks and average daily movements in the United States is illustrated in Fig. 425.

About 60 per cent of the areas of low barometer in the United States are first recorded over the extreme northwestern portion of the country, and thence they move eastward along the northern route.

When a low-pressure area is central over Idaho, for example, the precipitation within it will ordinarily be light, inasmuch as the air that circulates through it flows in from comparatively dry regions. The air currents from the Pacific rise rapidly as they flow inland and, cooling by expansion, they are deprived of a large portion of their moisture on the western side of the Cascade range of Mountains.

When the center of the disturbance has moved eastward across the Rocky Mountains the rainfall begins to increase in the eastern

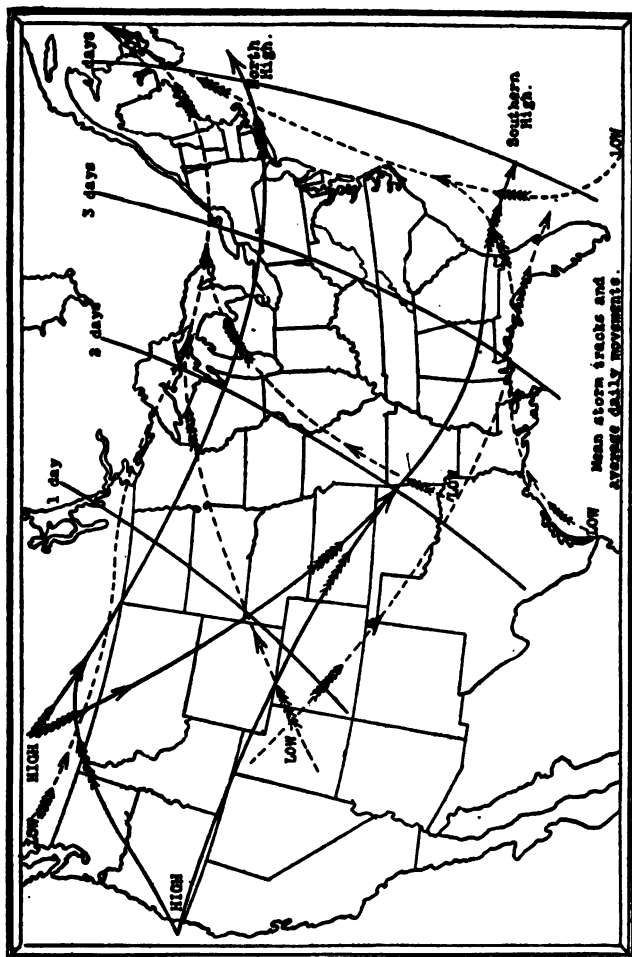

FIG. 425.—Storm tracks and average daily movements.



side of the area, occasioned by the **greater quantity of moisture** in the atmosphere that flows in from the central valleys and from the western portion of the Lake region. From thence eastward the storm usually **increases in energy** as it reaches into **lower altitudes** and moister regions, but ordinarily these disturbances do not cause heavy or excessive precipitation.

The **low pressure areas** that are first seen over the **southern plains**, and those that move into the **Southern States** from the **Gulf of Mexico** generally drift northeastward and pass off the north Atlantic coast. They are usually more intense and energetic than the disturbances that cross the country along the northern border because they move through moister and warmer regions.

A well-developed storm central over northern Texas and drifting toward the New England States is drawing warm air currents **heavily laden with moisture** from the Gulf of Mexico, during the entire time that it is crossing the great central valleys. The rainfall attending such storms is generally **heavy**. As these storms move farther northeastward, they pass between the Great Lakes and the Atlantic coast, and the **decreasing supply of moisture** from the Gulf is **replenished** from these other sources and **heavy rains** may and generally do continue.

The storms that move up from the Tropics to the South Atlantic or Gulf coasts of the United States during the late summer or early autumn are termed "**hurricanes**." They are usually smaller in area than the storms which form on the continent, but are more **intense** and energetic. When first observed in the Tropics, they have a tendency to move **slowly northwestward**, and to continue in that direction until they reach the latitude of the Gulf coast, when they recurve to the northeast unless prevented from doing so by an area of high barometric pressure. On recurring they usually **increase their rate of movement** and sometimes sweep over the **entire Atlantic coast in less than 48 hours**.

When a hurricane makes its appearance in southern waters it is necessary to receive frequent reports from all observation points in its vicinity and watch its movements very closely in order to issue warnings ahead of it.

**Cold waves**, (Fig. 426) usually accompany energetic areas of **high barometric pressure** following those of low pressure. They are confined principally to the winter months, when temperature changes are more sudden and pronounced.

During the winter season, if a high pressure area appears in the far northwest, with a low area over the southern states, the low area will usually move eastward and northeastward, while the **high area**, with its attendant **low temperatures** will sweep southward to the Gulf Coast. Should there be no well-defined area of low pressure over the Southern States, the high area would be more apt to pass eastward over the northerly route. A high-pressure area that is not preceded by a low will not cause so great a fall in temperature in proportion to its intensity as one that is thus preceded.

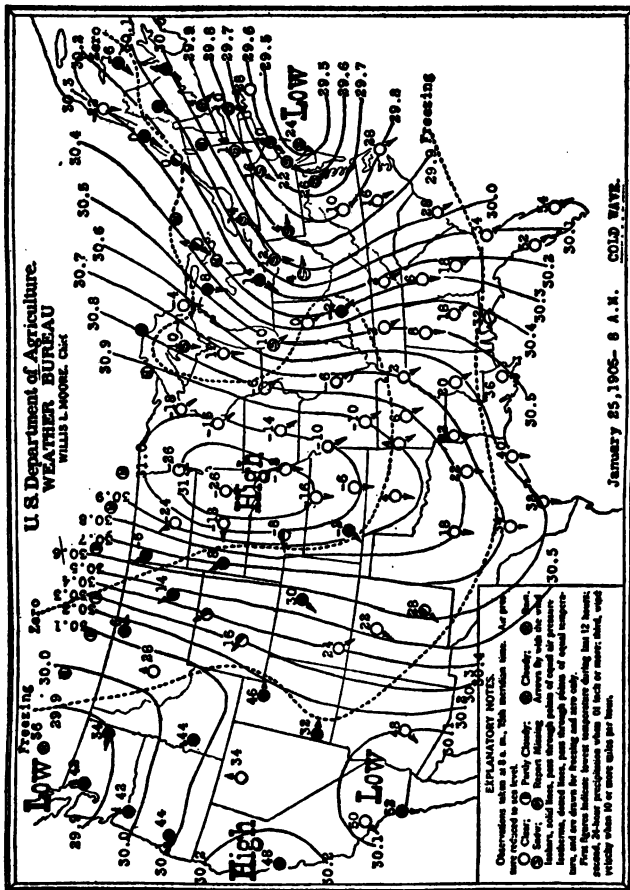

FIG. 426.—Map illustrating typical cold wave.

The high-pressure areas that move from the Northwest into the Southern States usually decrease in energy on recurving to the eastward or northeastward, and so reach the Atlantic States in a modified form that seldom causes a marked fall in temperature. When cold waves occur in the North Atlantic and New England States they follow closely upon the passage of a center of low pressure, the high-pressure area generally moving eastward or southeastward from the upper Lake region. Under certain conditions a cold wave may occur at the rear of a center of low pressure, with no well-defined high-pressure area following it, but in any event an increase in barometric pressure accompanies every cold wave.

When a cold area of high pressure is following a low from the Northwest the temperature will begin to fall at any given place in its track as soon as the center of the low has passed eastward far enough to bring that place within the flow of air between the two centers.

Excessive heat is caused by barometric pressure gradients being practically the reverse of those in a cold wave, the high pressure being in the Southeast and the low pressure in the Northwest. During the summer season an area of only moderately high barometric pressure will sometimes stagnate over the South Atlantic States or just off the coast, while a low moves into the upper Mississippi Valley and the upper Lake region. Under such conditions the air currents that flow from the central portion of the high area toward the low move along the surface and, steadily increasing in temperature, they gather up moisture over their course and cause abnormally warm and humid conditions in the Ohio Basin and in the Middle and North Atlantic States. If the areas are large, with the crest of high pressure off the south Atlantic Coast and the center of the low in the far Northwest, the abnormally high temperatures will cover all the great central valleys.

The month of July 1901, marked the most intense period of abnormal heat from the Atlantic coast westward to the Rocky Mountains that has been recorded in the United States. The average barometric pressure for the month serves to illustrate the conditions that caused the intense heat much better than a map for any specific date, and a chart showing the average pressure for that period has been taken from the monthly Weather Review and adapted to this purpose. (Fig. 427.)

In the Northern States much the greater portion of the rainfall occurs on the eastern and southern sides of low-pressure areas. The heaviest rains in the Southern States are usually caused by low-pressure areas moving in from the Gulf, but rain often occurs when an area of high pressure moves down from the north, the cool descending air currents appearing to run under the moist lower air strata which are raised, cooled by expansion, and a portion of their moisture condensed and precipitated.

The areas of high and low barometric pressure are more energetic excepting the West Indian Hurricanes, and move across the country

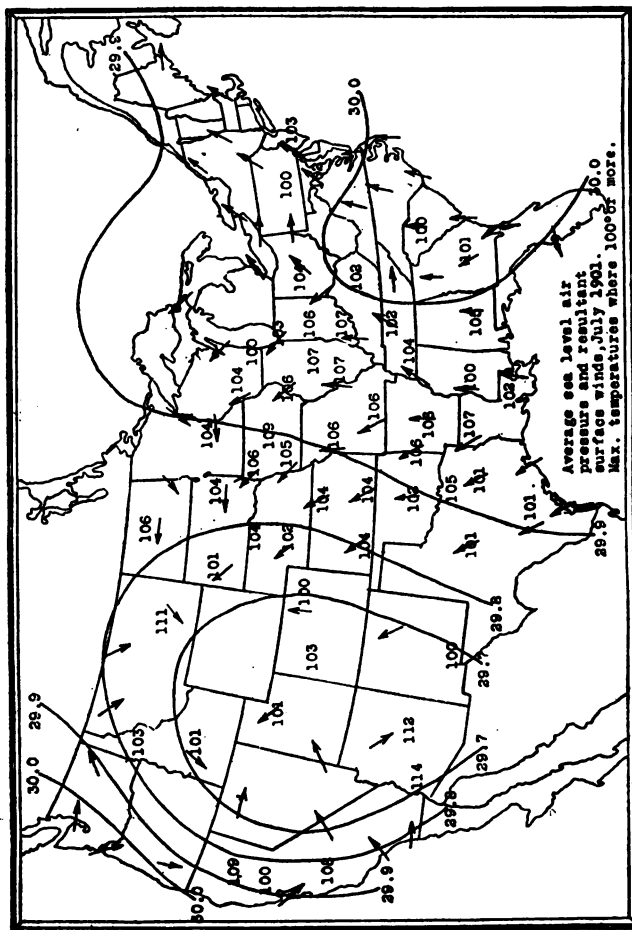

Fig. 427.—Map illustrating hot wave.

at a more rapid rate during the winter than during the summer season. The rate of movement of a storm area across the country should not be confused with the wind velocities within its boundaries, for sometimes a storm that is moving quite rapidly will be suddenly checked and will increase in energy as a consequence, thus developing higher wind velocities than when its movement of translation was greater. The West Indian hurricanes travel very slowly so long as they follow the westerly course, but the wind velocities generated within them are usually destructive.

The rate of movement of storm areas is seldom steady and uniform for any considerable length of time, but the average rate is about 37 miles per hour in winter and 22 miles per hour in summer. They travel faster across the Northern States than they do in the southern portion of the country.

High pressure areas have a greater tendency to turn southward while crossing the great central valleys in the winter than they have during the summer. The larger and better formed all atmospheric disturbances are, the easier it becomes to anticipate their movements and developments and thereby to forecast ahead of them. It is when a map shows several partly developed areas, or when their movements become sluggish, that forecasting becomes most difficult.

During the midsummer when the pressure formations are least energetic there is a tendency for conditions to become localized, and we have showers instead of general rains. When conditions indicate showers a forecast must be made of them, and while they may cover much the greater portion of the territory for which they are forecast, still there will be many places where no rain will occur.

When conditions are such as to indicate only a few widely scattered showers, fair weather will no doubt prevail over three-fourths of the territory covered by the forecast.

**5. THE THUNDERSTORM.\*** In a thunderstorm, the thunder and lightning constitute no essential part of the storm in the sense of being the cause or the maintaining factors of it, but are rather the result of the conditions within the storm.

**6. Phenomena of Lightning.** The source, or cause, of atmospheric electricity remained a mystery until a few years ago when the experiments of Simpson an English scientist, shed much light upon the subject. He experimented in the laboratory with blasts of air directed against drops of distilled water, the force of the blast being great enough to break the drops up into a spray. The spray was negatively electrified, while the larger drops left behind were positively electrified. He further devised a clever combination of recording devices which automatically measured the quantity of rainfall together with the amount and kind of electricity brought down by the rain. Experiments conducted in India with this device showed that two or three times as much positive as negative

---

\*From a lecture delivered by Dr. William J. Humphreys to the Philadelphia Electric Co. Section of the N. E. L. A.

electricity is brought down by the **thunderstorm** rain. Both experiments have since been repeated in nearly every country, and in every instance his findings have been confirmed. The results of these experiments fit in nicely with the known conditions in thunderstorms and furnish a reasonable explanation of the phenomena of lightning. In a thunderstorm the uprush of air is violent at times, as is evidenced by lumps of hail that can only be formed by the carrying of raindrops to very high altitudes. When moisture particles **coalesce** into large drops and are then blown into a **spray** by the strong uprushing air currents, the laboratory experiment of electrical separation is duplicated. The spray which is negatively electrified is carried aloft while the **larger drops** left behind, and which are **positively electrified**, fall to earth, thus explaining why such a large portion of **positive electricity** is brought down by rain.

**7. Causes of the Strong Uprushing Air Currents.** It has been found that, starting from the surface of the earth, the temperature decreases rather steadily to an elevation of from 30,000 to 40,000 feet above sea level. If a body of air at the earth's surface should be carried upward its temperature would decrease practically uniformly, the loss of heat being due to the work of expansion against the force of gravity. The heating of the atmosphere, as it does on a warm summer afternoon; causes it to rise by convection until it reaches an altitude where cloud begins to form. Starting, for example, with a temperature of 86° Fahrenheit and a relative humidity of 15 per cent, clouds will form at an altitude of about 5000 feet, the temperature of the rising air having fallen to 59°. As soon as cloud begins to form latent heat is freed and decreases the rate of cooling so that the air within the cloud becomes warmer than the surrounding air. Being warmer it is less dense and is forced upward by the heavier air around it. The **more rapid the condensation**, and the consequent freeing of latent heat, the **greater** will be the temperature difference between the air in the cloud and of that surrounding it, and the **stronger** will be the **resulting uprush** of the air within the **cumulus** cloud. The formation of a cumulus cloud, (Fig. 428) with its piles upon piles of **cauliflower like heads**, is a **visible demonstration** of the action that is taking place within.

**8. Time and Localities Favoring Thunderstorms.** The formation of a thunderstorm requires first of all enough heat to cause rising convective air currents to the altitude where condensation begins, and second a moist air which will favor rapid condensation. In consequence they are **most frequent in moist equatorial regions**, and **least frequent in the cooler regions of the north and over large dry plains or deserts**. They are more frequent during **afternoons** than during the morning hours over the land, while over the ocean they are most frequent at night, because the **temperature conditions** at those times favor vertical convection. Thunderstorms are most frequent over the land in **summer**, when the amount of heat received is **greatest**, while over the ocean they are most frequent in **winter**,

## Sec. 11

## METEOROLOGICAL DATA

since the temperature of the ocean does not vary greatly from winter to summer while the air blowing over it from the land does do so and thus causes the temperature gradients that bring about rapid vertical convection.

9. **RAIN.\*** When moisture laden air rises into strata that are less dense it expands. The work of expansion, against the force of gravity, consumes heat, thus lowering its temperature and lessening its capacity for moisture. The lessening of air density does not materially affect its capacity for moisture except insofar as it reduces the temperature. This would indicate that the atmospheric gases do not absorb the water vapor, but that the vapor diffuses through the space nearly independent of the atmospheric gases, and controlled mainly by the temperature. When cooling continues to the point of saturation then condensation begins and cloud is



FIG. 428.—Cumulus cloud.

formed. The first visible moisture particles may be supported by the rising air currents, but if condensation be continued long enough and rapidly enough, the drops will coalesce and become large and heavy enough to fall through the rising air currents and reach the earth as rain. Dust particles usually act as the nuclei of condensation, but it has been shown that ionized air may act in that capacity, and that it probably does to some extent. If saturated air be cooled 20° F. it will lose practically one-half of its moisture, this being true within the range of temperatures ordinarily experienced in the free air.

10. **SNOW.\*** When condensation is rapid enough to cause precipitation while the temperature is below the freezing point, snowflakes are formed instead of raindrops.

---

\* Information supplied by Mr. Geo. S. Bliss, U. S. Dept. of Agriculture, Weather Bureau.

**11. HAIL.\*** Hail rarely occurs except as an accompaniment of a thunderstorm, and in which the vertical air currents are very strong. The raindrops are carried by these vertical air currents up into air strata in which the temperature is below the freezing point, then fall back into the cloud, become coated with moisture, and are again carried up into the cold air strata. This process may be repeated several times when the vertical currents are unusually strong, and the hailstone may build up its concentric layers until it becomes quite large.

**12. ICE STORMS.\*** These peculiar phenomena, popularly called sleet storms, occur under conditions that are known to meteorologists as inversion of temperature, that is, the air at some distance above the earth is warmer than at the surface. After a more or less protracted cold spell, during which the ground has become frozen, and the walls of buildings and other exposed surfaces are cooled below the freezing point, the air at some distance above the earth may be warmed quite rapidly to a point above freezing, while that near the cold surfaces may remain at or slightly below freezing. If precipitation occurs at such times it passes through the warmer air strata as rain, but is frozen on coming into contact with the cold surfaces, thus forming a coating of ice.

**13. SLEET.\*** Sleet, properly speaking, is frozen rain drops. It usually occurs intermingled with rain, but may fall as clear ice pellets, unmixed with rain. These pellets should not be confused with hailstones which are larger and are made up of concentric layers; neither should they be confused with white, opaque pellets of hard snow.

**14. DISCUSSION OF SLEET DATA.** The data submitted is necessarily incomplete in so far as the amount of sleet formation on wires is concerned; where recorded wind velocities and temperatures are tabulated they represent the worst conditions that government records show for that particular station during a sleet storm.

Much higher wind velocities and lower temperatures are recorded at various periods during the year at these stations, but they did not occur during a sleet storm.

A summary of the data obtained follows:

(1) The number of years record covers a period of from five (5) to forty-three (43) years.

(2) The maximum recorded wind velocity of 487 sleet storms was greater than 40 miles per hour in 31 instances (6.36%); greater than 50 miles per hour in 12 instances (2.46%); and greater than 60 miles per hour in five (5) instances (1.03%).

---

\* Information supplied by Mr. Geo. S. Bliss, U. S. Dept. of Agriculture, Weather Bureau.



**TABLE 112**  
**MONTHLY MEAN MAXIMUM TEMPERATURES**

Mean Maximum Monthly Temperature—Averaged for the  
Number of Years Recorded

STATIONS	Years record											
	January	February	March	April	May	June	July	August	September	October	November	December
Abilene, Tex. ....	23	56	68	76	83	89	91	92	86	78	65	56
Albany, N. Y. ....	40	31	32	41	55	69	78	82	80	72	60	46
Alpena, Mich. ....	39	26	26	34	47	59	70	76	73	66	54	40
Birmingham, Ala. ....	10	54	56	68	73	82	88	90	90	81	75	65
Boise, Idaho. ....	15	39	43	52	62	69	78	88	86	76	64	52
Boston, Mass. ....	42	36	36	41	54	66	75	81	78	71	61	49
Buffalo, N. Y. ....	40	31	31	38	50	62	72	76	78	70	58	45
Charleston, S. C. ....	43	58	59	66	72	80	86	88	87	82	74	64
Chicago, Ill. ....	41	31	33	42	54	65	74	80	78	72	60	46
Cincinnati, Ohio. ....	39	40	42	52	63	74	82	86	84	78	66	52
Cleveland, Ohio. ....	43	33	34	42	54	66	75	79	77	72	61	47
Denver, Colo. ....	39	43	44	52	60	69	80	86	85	77	65	52
Detroit, Mich. ....	40	31	32	41	55	67	78	81	79	72	60	45
Dubuque, Iowa. ....	40	27	30	42	50	70	79	84	82	74	61	44
Duluth, Minn. ....	43	18	22	32	46	57	69	74	71	64	52	36
Fort Smith, Ark. ....	31	49	51	63	72	80	87	88	91	85	74	62
Galveston, Tex. ....	36	56	61	68	71	80	86	88	88	85	77	63
Green Bay, Wis. ....	27	23	25	36	52	64	76	80	77	70	57	41
Havre, Mont. ....	12	23	34	38	57	65	74	82	80	69	58	40
Kansas City, Mo. ....	25	38	38	52	65	74	83	87	86	79	68	53
Knoxville, Tenn. ....	40	47	50	59	68	78	84	87	86	81	70	58
Los Angeles, Cal. ....	36	65	66	67	70	73	78	82	83	82	77	72
Memphis, Tenn. ....	40	48	51	61	71	79	86	89	88	82	72	60
New Orleans, La. ....	40	62	64	71	76	83	87	89	89	85	75	63
New York, N. Y. ....	42	37	38	45	57	68	77	82	80	74	63	51
Norfolk, Va. ....	38	49	50	57	65	75	83	87	84	79	69	59
North Platte, Neb. ....	39	35	38	49	62	70	80	86	84	77	65	50
Omaha, Neb. ....	41	39	34	46	62	72	81	86	84	78	64	48
Philadelphia, Pa. ....	37	39.3	40.3	48.3	60.2	71.5	80.2	84.7	82.2	76.3	64.7	52.3
Phoenix, Ariz. ....	17	66	68	74	82	90	100	108	101	97	85	74
Pittsburg, Pa. ....	39	38.7	39.7	48.8	60.6	72.9	80.7	84.6	82.6	76.8	65.5	50.7
Rapid City, S. D. ....	26	34	33	43	58	65	76	83	83	74	61	47
Roseburg, Ore. ....	36	47	51	57	62	68	73	81	81	74	64	54
St. Paul, Minn. ....	41	20	24	37	56	68	77	82	80	71	57	40
Salt Lake City, Utah. ....	33	37	41	51	60	68	79	88	87	76	63	50
San Francisco, Cal. ....	17	54	58	59	62	62	64	64	65	67	61	59
Santa Fe, N. M. ....	39	39	43	52	60	68	78	81	79	73	62	50
Shreveport, La. ....	40	56	59	68	76	83	90	92	92	87	77	66
Spokane, Wash. ....	33	33.1	33.0	43.0	59.2	67.5	74.0	82.9	82.2	77.1	68.9	54.4
Tampa, Fla. ....	24	69	70	77	80	86	89	89	89	82	76	70
Washington, D. C. ....	42	41.4	43.0	51.5	63.0	74.4	82.2	86.5	83.8	77.9	66.9	54.3
Wichita, Kansas. ....	26	42	43	56	68	76	85	90	90	82	70	55
Williston, N. D. ....	35	17	19	33	55	66	75	82	81	70	56	37

TABLE 113

MONTHLY MEAN MINIMUM TEMPERATURES.

Mean Minimum Monthly Temperature—Averaged for the Number of Years Recorded.

STATIONS	Years record												
	January	February	March	April	May	June	July	August	September	October	November	December	
Abilene, Tex.	28	34	35	45	53	61	68	72	72	65	54	43	36
Albany, N. Y.	40	15	15	25	37	49	58	63	61	54	43	32	21
Alpena, Mich.	39	12	9	17	31	41	51	57	55	49	39	29	19
Birmingham, Ala.	10	38	37	46	53	62	68	71	71	66	54	45	37
Boisé, Idaho.	15	26	27	34	39	45	51	58	56	48	40	34	25
Boston, Mass.	42	20	20	28	38	48	58	64	62	55	45	35	25
Buffalo, N. Y.	40	19	17	25	35	46	57	63	61	55	44	33	24
Charleston, S. C.	43	43	44	50	57	66	72	75	75	71	60	51	44
Chicago, Ill.	41	17	19	28	39	49	59	66	65	58	46	33	23
Cincinnati, Ohio.	39	25	26	35	45	55	65	68	66	60	48	37	29
Cleveland, Ohio.	43	20	20	28	39	50	60	64	62	56	45	34	25
Denver, Colo.	39	17	20	26	35	44	52	58	57	49	37	26	20
Detroit, Mich.	40	18	18	26	37	49	58	63	61	55	44	33	24
Dubuque, Iowa.	40	11	13	25	39	50	59	64	62	54	42	28	18
Duluth, Minn.	43	1	4	15	31	40	48	56	57	49	38	23	10
Fort Smith, Ark.	31	30	32	42	51	59	67	70	70	63	51	41	33
Galveston, Tex.	36	45	50	58	62	71	77	79	78	75	68	58	51
Green Bay, Wis.	27	8	8	20	34	45	55	60	58	51	41	27	17
Havre, Mont.	33	2	4	16	33	41	50	54	51	43	33	19	12
Kansas City, Mo.	25	21	21	33	46	55	64	69	68	60	48	35	26
Knoxville, Tenn.	40	30	32	40	48	56	64	68	66	61	48	38	32
Los Angeles, Cal.	36	44	45	47	49	54	56	59	60	57	53	48	46
Memphis, Tenn.	40	34	36	45	53	62	70	73	71	65	54	43	38
New Orleans, La.	40	45	50	56	61	68	74	76	76	72	63	54	48
New York, N. Y.	42	24	24	31	41	52	61	67	66	60	49	38	28
Norfolk, Va.	38	33	34	40	48	58	66	71	70	65	54	44	36
North Platte, Neb.	39	11	16	23	36	47	56	61	60	50	36	23	16
Omaha, Neb.	41	12	16	27	41	53	62	67	65	54	44	32	19
Philadelphia, Pa.	37	25.7	25.9	32.9	42.8	53.5	62.8	68.1	66.5	60.4	49.0	38.7	29.2
Phoenix, Ariz.	17	39	43	47	52	59	69	76	76	68	56	46	38
Pittsburg, Pa.	39	23.6	24.3	31.3	41.4	52.4	60.8	65.0	63.0	57.3	45.7	35.7	27.4
Rapid City, S. D.	26	11	11	20	34	43	53	58	57	48	37	24	18
Roseburg, Ore.	36	35	36	38	41	45	49	53	52	48	43	40	36
St. Paul, Minn.	41	3	6	20	36	48	58	62	60	51	40	24	12
Salt Lake City, Utah.	38	22	26	33	40	46	55	63	62	52	42	32	25
San Francisco, Cal.	17	45	47	47	49	50	51	52	53	54	53	50	46
Santa Fé, N. M.	39	19	22	29	35	43	52	57	56	50	38	28	20
Shreveport, La.	40	39	41	49	56	64	70	73	72	67	56	46	41
Spokane, Wash.	33	21.1	23.1	30.7	37.3	44.5	50.4	55.1	53.6	45.8	37.9	31.2	26.3
Tampa, Fla.	24	51	53	58	61	67	71	73	74	72	66	58	52
Washington, D. C.	42	25.8	26.5	33.8	43.3	54.0	62.8	67.6	65.7	59.0	47.1	36.6	28.6
Wichita, Kansas.	26	23	23	34	45	55	64	68	67	60	48	35	26
Williston, N. D.	35	-5	-2	12	31	41	52	54	52	41	31	16	5

TABLE 114  
TOTAL NUMBER OF DAYS WITH MAXIMUM  
TEMPERATURE 90° OR ABOVE.

STATIONS	Years record	January	February	March	April	May	June	July	August	September	October	November	December
Abilene, Tex.	27	0	1	24	50	155	417	552	635	291	41	0	0
Albany, N. Y.	46	0	0	0	0	12	53	135	63	18	1	0	0
Alpena, Mich.	39	0	0	0	0	7	24	44	21	19	0	0	0
Birmingham, Ala.	16	0	0	1	0	14	86	89	123	65	13	0	0
Boisé, Idaho.	15	0	0	0	2	7	48	223	184	31	0	0	0
Boston, Mass.	42	0	0	0	0	10	67	185	58	21	0	0	0
Buffalo, N. Y.	43	0	0	0	0	1	1	17	6	1	0	0	0
Charleston, S. C.	43	0	0	6	0	51	233	417	275	58	4	0	0
Chicago, Ill.	43	0	0	0	0	11	63	168	98	49	0	0	0
Cincinnati, Ohio.	39	0	0	0	0	23	164	357	239	162	0	0	0
Cleveland, Ohio.	43	0	0	0	0	1	14	37	30	0	0	0	0
Denver, Colo.	39	0	0	0	0	9	191	439	334	56	1	0	0
Detroit, Mich.	46	0	0	0	0	5	35	108	59	23	0	0	0
Dubuque, Iowa.	46	0	0	0	0	18	113	248	148	51	0	0	0
Duluth, Minn.	43	0	0	0	0	0	14	41	13	3	0	0	0
Fort Smith, Ark.	31	0	0	3	7	45	294	598	575	296	42	0	0
Galveston, Tex.	40	0	0	0	0	6	120	236	223	61	3	0	0
Green Bay, Wis.	27	0	0	0	0	2	43	74	47	36	0	0	0
Havre, Mont.	30	0	0	0	1	11	44	178	149	24	0	0	0
Kansas City, Mo.	25	0	0	4	2	11	132	264	266	117	4	0	0
Knoxville, Tenn.	39	0	0	0	2	29	181	345	257	93	11	0	0
Los Angeles, Cal.	36	0	0	4	20	22	50	98	149	100	75	23	0
Memphis, Tenn.	40	0	0	0	0	31	337	553	424	192	6	0	0
New Orleans, La.	43	0	0	0	0	43	384	625	569	232	12	0	0
New York, N. Y.	42	0	0	0	0	9	61	136	54	24	0	0	0
Norfolk, Va.	43	0	0	3	3	46	180	400	226	65	0	0	0
North Platte, Neb.	39	0	0	0	5	30	150	371	365	112	5	0	0
Omaha, Neb.	41	0	0	1	4	23	168	381	283	124	2	0	0
Philadelphia, Pa.	43	0	0	0	4	18	126	242	100	34	0	0	0
Phoenix, Ariz.	17	0	1	10	75	276	480	513	509	450	150	5	0
Pittsburg, Pa.	39	0	0	0	0	43	122	279	183	79	3	0	0
Rapid City, S. D.	26	0	0	0	0	5	65	169	181	69	1	0	0
Roseburg, Ore.	36	0	0	0	0	9	34	148	122	54	6	0	0
St. Paul, Minn.	25	0	0	0	0	2	50	82	54	31	0	0	0
Salt Lake City, Utah.	38	0	0	0	0	5	103	472	371	25	0	0	0
San Francisco, Cal.	39	0	0	0	0	2	18	6	3	20	5	0	0
Santa Fé, N. M.	37	0	0	0	0	0	0	8	29	11	0	0	0
Shreveport, La.	46	0	0	2	17	143	652	904	871	444	58	0	0
Spokane, Wash.	24	0	0	0	0	4	30	155	152	9	0	0	0
Tampa, Fla.	24	0	0	0	4	70	254	305	319	196	15	0	0
Washington, D. C.	43	0	0	3	5	65	204	417	233	90	3	0	0
Wichita, Kansas.	26	0	0	6	11	25	195	397	438	198	8	0	0
Williston, N. D.	32	0	0	0	4	18	77	176	182	33	2	0	0

TABLE 115

TOTAL NUMBER OF DAYS WITH MINIMUM TEMPERATURE ZERO OR BELOW.

STATIONS	Years record	January	February	March	April	May	June	July	August	September	October	November	December
	Abilene, Tex.	27	3	4	0	0	0	0	0	0	0	0	0
Albany, N. Y.	40	148	150	14	0	0	0	0	0	0	0	1	62
Alpena, Mich.	39	201	273	113	1	0	0	0	0	0	0	2	41
Birmingham, Ala.	10	0	1	0	0	0	0	0	0	0	0	0	0
Boise, Idaho.	15	11	5	0	0	0	0	0	0	0	0	0	0
Boston, Mass.	42	48	40	4	0	0	0	0	0	0	0	1	24
Buffalo, N. Y.	43	55	86	4	0	0	0	0	0	0	0	0	11
Charleston, S. C.	43	0	0	0	0	0	0	0	0	0	0	0	0
Chicago, Ill.	41	172	121	10	0	0	0	0	0	0	0	6	67
Cincinnati, Ohio.	38	36	27	0	0	0	0	0	0	0	0	0	15
Cleveland, Ohio.	43	55	37	5	0	0	0	0	0	0	0	1	15
Denver, Colo.	39	156	114	20	0	0	0	0	0	0	0	22	95
Detroit, Mich.	40	77	93	5	0	0	0	0	0	0	0	0	21
Dubuque, Iowa.	40	334	230	24	0	0	0	0	0	0	0	12	151
Duluth, Minn.	43	616	453	165	0	0	0	0	0	0	0	63	321
Fort Smith, Ark.	31	11	6	0	0	0	0	0	0	0	0	0	0
Galveston, Tex.	43	0	0	0	0	0	0	0	0	0	0	0	0
Green Bay, Wis.	27	233	215	51	0	0	0	0	0	0	0	7	97
Havre, Mont.	9	142	104	49	1	0	0	0	0	0	1	24	61
Kansas City, Mo.	25	52	51	0	0	0	0	0	0	0	0	0	13
Knoxville, Tenn.	41	13	6	0	0	0	0	0	0	0	0	0	3
Los Angeles, Cal.	36	0	0	0	0	0	0	0	0	0	0	0	0
Memphis, Tenn.	40	7	4	0	0	0	0	0	0	0	0	0	0
New Orleans, La.	43	0	0	0	0	0	0	0	0	0	0	0	0
New York, N. Y.	42	6	7	0	0	0	0	0	0	0	0	0	4
Norfolk, Va.	43	0	0	0	0	0	0	0	0	0	0	0	0
North Platte, Neb.	39	235	183	42	0	0	0	0	0	0	0	30	117
Omaha, Neb.	41	307	188	16	0	0	0	0	0	0	0	12	133
Philadelphia, Pa.	43	10	11	0	0	0	0	0	0	0	0	0	2
Phoenix, Ariz.	17	0	0	0	0	0	0	0	0	0	0	0	0
Pittsburg, Pa.	39	40	47	0	0	0	0	0	0	0	0	0	14
Rapid City, S. D.	26	212	202	71	1	0	0	0	0	0	0	27	86
Roseburg, Ore.	36	2	0	0	0	0	0	0	0	0	0	0	0
St. Paul, Minn.	41	553	416	97	0	0	0	0	0	0	0	63	250
Salt Lake City, Utah.	38	20	13	1	0	0	0	0	0	0	3	4	41
San Francisco, Cal.	39	0	0	0	0	0	0	0	0	0	0	0	0
Santa Fé, N. M.	37	35	19	1	0	0	0	0	0	0	0	0	20
Shreveport, La.	40	0	2	0	0	0	0	0	0	0	0	0	0
Spokane, Wash.	25	35	22	0	0	0	0	0	0	0	0	5	2
Tampa, Fla.	24	0	0	0	0	0	0	0	0	0	0	0	0
Washington, D. C.	43	16	2	0	0	0	0	0	0	0	0	0	2
Wichita, Kansas.	26	37	26	0	0	0	0	0	0	0	0	0	6
Williston, N. D.	32	503	494	258	5	0	0	0	0	0	1	132	335

TABLE 116

### HIGHEST WIND VELOCITIES ON RECORD, WITH DIRECTION.

(The recorded velocities as given are the greatest maintained for any five minute period.)

STATIONS.	Years Record.	January.	February.	March.	April.	May.
Abilene, Tex. ....	27	60W	61W	50SW	60SW	66SW
Albany, N. Y. ....	40	60NW	70W	54NW	48NW	41NW
Alpena, Mich. ....	39	56SE	53SE	55W	52W	47S
Birmingham, Ala. ....	10	50SE	43SE	40SE	45S	44SE
Boisé, Idaho. ....	15	38NW	33NW	32NW	40SE	42SW
Boston, Mass. ....	41	64NE	60E	72S	60NE	48E
Buffalo, N. Y. ....	42	90SW	76SW	90W	75SW	61SW
Charleston, S. C. ....	43	44SW	56SE	55NE	67SE	53NE
Chicago, Ill. ....	24	66NE	84NE	63NE	72NE	72SW
Cincinnati, Ohio. ....	46	48SW	41NW	48SW	44SW	45N
Cleveland, Ohio. ....	43	72W	65W	63W	66W	60NW
Denver, Colo. ....	41	66SW	64W	61NW	60NW	63NW
Detroit, Mich. ....	43	60W	60SW	66W	72NE	74SW
Dubuque, Iowa. ....	40	38NW	36NW	42SW	39NW	34NW
Duluth, Minn. ....	43	71NW	60NE	62NE	70NW	60NE
Fort Smith, Ark. ....	31	66W	54W	56SW	56SW	54S
Galveston, Tex. ....	42	62N	59N	61N	52N	60NW
Green Bay, Wis. ....	27	47NE	55N	48NW-SW	46NE	63N
Havre, Mont. ....	33	60SW	72NW	60W	63W	63NW
Kansas City, Mo. ....	25	74NW	53NW	58SW	56NW	53NW
Knoxville, Tenn. ....	41	58SW	60SW	84S	70W	56SW
Los Angeles, Cal. ....	36	48NE	42NW	46SW	42W	36W
Memphis, Tenn. ....	40	64W	58W	75SW	64NW	68NW
New Orleans, La. ....	41	42NW	52SE	46SW	48N	48NW
New York, N. Y. ....	30	86SW	96SW	89N	84NW	64NW
Norfolk, Va. ....	42	64SW	59NW	58SW	55N	62N
Northplatte, Neb. ....	39	58NW	68NW	66NW	96SE	84SE
Omaha, Neb. ....	41	66NW	49NW	52NW	52NW	50
Philadelphia, Pa. ....	43	53-ENW	48NE-NW	60NW	50W	60NW
Phoenix, Ariz. ....	17	30N	32W	36SW	34W	33SW
Pittsburg, Pa. ....	41	66W	58W	67W	63W	57NW
Rapid City, S. D. ....	26	51W	52N	66SW	63SW	56W
Roseburg, Ore. ....	36	30SW	36SW	42W	42W	36SW
St. Paul, Minn. ....	25	54N	46NW	60NW	50NW	53SW
Salt Lake City, Utah. ....	38	60N	60N	60NW	69N-SW	56W
San Francisco, Cal. ....	42	57SE	48S	68S	42SE	45W
Santa Fé, N. M. ....	40	44NW	47W	50E	51SW	51SW
Shreveport, N. M. ....	42	40NW-N	39SE	54NW	44W	52SE
Spokane, Wash. ....	33	40SW	41SW	44SW	40SW	38SW-W
Tampa, Fla. ....	24	40W	48S	41SW	42SW	42SE
Washington, D. C. ....	43	48NW	60	50NW	48NW	54SW
Wichita, Kansas. ....	26	62NW	49N	68S	54SE	56SW
Williston, N. D. ....	32	66NW	72NW	60NW-N	66NW	66E

TABLE 116—Continued

HIGHEST WIND VELOCITIES ON RECORD,  
WITH DIRECTION.

(The recorded velocities as given are the greatest maintained for any five minute period.)

Years Record.	June.	July.	August.	September.	October.	November.	December.
27	62NE	60SE	48NW	42SW	40NW	48NE	60W
28	48NW	70W	44SE	39SE	70E	52SE	70W-E
29	48W	60SW	41NW	51SE	52E	50NW	46NW
10	39E	45SE	58NE	50SE	33SE	39SE	48S
15	56SW	41NE	34NE	40W	48NW	43W	33W
41	41E	60SW	48S	60N	54NE	65W	60E
42	72NW	66SW	60SW	78W	75SW	80W	78W
43	54E	48S	106SE	62S	64N	46E	50SE
24	72NW	72W	72SW	72SW	63SE	76S	72SW
40	52NW	43SW	50NW	40NW	41SW	48SW	40NW
43	64SW	66NW	58W	60NW	62W	73S	61S
41	60SE	55NE	75NE	51N	55S	60NW	56
43	69NW	60W-SW	60NW	60NW	61NW	76SW	56SW
40	60NW	56NW	45NE	42NW	36NW	42NW	42NW
43	63NE	56NW	51NW	78NE	58NW	70NW	65NW
31	74S	49NW	64W	52W	46NW	55NW	43W
42	54SE	68E	53NE	84NE	62NW	54NW	54N
27	59W	59NW	45NW	52NW	52NE	54N-SW	48SW-N
33	76NW	59W	60SW	56SW	60SW	60NW	60NW
25	67N	57NW	55NW	48SW	45S	50NW	46NW
41	52W	80N	70NW	60SW	36SE	60	54SW
26	34SW	25W	24NE	38S	34NE	43NE	38NW
40	60NW	54W	59NW	60NW	72SW	66SW	56SW
41	50N	52E	60E	64SE	54N	42N	48N
30	72NW	72NW	76NW	72SW	76NW	76W	85NW
42	49W	60N	60NE	56SE	60SW	50NW	58NW
29	90SW	34W	66NW	72W	62S	62NW	72NW
41	60NW	64NE	54NE	54NE	43NW	51NW	50NW
43	54NW	53N	55NE	58NW	75SE	60E	63SE
17	32NW	48SE	40E	38W	36SE	26W	30SW
41	58NW	52NW	55NW	44SW	60NW	50W	69W
26	59SW	60N	60SW	48NW	46W	60NW	56SW
26	28SW	28SW	41NE	30SW	28SW	30NE-SW	48SW
25	64NW	62N	102NW	55SE	55W	52N	48N-NW
28	54NW	50E	64W	44E	52NE	66NW	50NW
42	48SW	41W	42SW	40W	44NE	64NE	60SE
40	48NW	45W	40E	46N	53SE	51SE	40NE
42	46N	56S	43NE	38W	60NW	54NW	52W
42	48SW	53W	39SE-SW	48W	40SW	42SW	48SW
24	44SW	43SE	34SE	48NE	48N	36S	40S
42	51NW	60NE	53N	66SE	51NW	54SW	49
26	46S	56NW	48NW	47W	48S	53S	45S
32	63NW	54NW-N	67W	60NW	60NW-N	60NW	60NW-W

TABLE 117

**TOTAL NUMBER OF DAYS WITH MAXIMUM RECORDED  
VELOCITY OF 40 MILES PER HOUR OR MORE.**

STATIONS	Years record	January	February	March	April	May	June	July	August	September	October	November	December
	No. Da.												
Abilene, Tex.	27	20	30	30	33	25	13	7	7	3	3	9	12
Albany, N. Y.	33	5	6	6	1	1	0	7	3	0	2	2	6
Alpena, Mich.	39	18	15	26	26	9	9	3	3	9	15	16	
Birmingham, Ala.	10	1	4	3	1	1	0	1	1	1	0	2	2
Boisé, Idaho	15	0	0	0	1	2	1	2	0	1	1	1	0
Boston, Mass.													
Buffalo, N. Y.	22	191	148	133	62	60	26	39	40	58	91	132	213
Charleston, S. C.	23	4	17	11	14	9	9	3	15	12	15	2	5
Chicago, Ill.	24	92	107	143	155	116	61	59	37	55	85	126	107
Cincinnati, Ohio	40	8	5	5	2	1	4	7	3	1	3	2	1
Cleveland, Ohio	43	124	113	111	85	57	39	46	16	42	75	122	99
Denver, Colo.	22	29	21	33	33	29	14	21	14	11	16	27	30
Detroit, Mich.	23	33	34	46	52	26	15	21	4	10	23	39	29
Dubuque, Iowa	40	0	0	2	0	0	2	2	2	1	0	1	1
Duluth, Minn.	43	72	60	64	52	46	21	17	11	23	33	54	61
Fort Smith, Ark.	20	11	18	25	21	19	16	9	3	6	3	6	3
Galveston, Tex.	22	21	22	16	21	20	8	3	3	7	11	14	25
Green Bay, Wis.	27	18	19	22	35	26	10	21	8	6	18	21	12
Havre, Mont.	22	29	16	19	20	20	20	27	12	20	12	19	37
Kansas City, Mo.	25	9	19	28	27	22	13	14	12	4	7	11	10
Knoxville, Tenn.	22	11	15	20	10	5	3	5	12	2	0	6	10
Los Angeles, Cal.	36	2	1	1	1	0	0	0	0	0	0	2	0
Memphis, Tenn.	24	22	29	23	30	16	25	10	10	2	4	12	11
New Orleans, La.	21	2	5	4	6	1	3	3	4	5	3	1	4
New York, N. Y.	22	133	173	163	119	67	45	51	22	36	79	116	123
Norfolk, Va.	32	20	28	28	11	16	9	10	14	3	10	14	13
North Platte, Neb.	39	16	12	32	33	34	39	13	9	7	14	14	6
Omaha, Neb.	41	12	14	20	22	8	11	7	4	4	4	10	13
Philadelphia, Pa.	43	25	21	13	16	6	6	5	3	4	10	15	19
Phoenix, Ariz.	17	0	0	0	0	0	0	0	2	2	0	0	0
Pittsburg, Pa.	41	23	24	33	30	12	18	12	4	6	10	15	23
Rapid City, S. D.	26	23	20	13	24	12	16	7	6	13	6	19	15
Roseburg, Ore.	36	0	0	1	0	0	0	1	1	0	0	0	2
St. Paul, Minn.	22	16	8	22	21	14	15	20	11	7	12	12	14
Salt Lake City, Utah	22	12	10	11	14	13	9	17	5	8	9	8	10
San Francisco, Cal.	7	4	1	3	21	0	0	0	9	0	0	1	1
Santa Fé, N. M.	40	2	7	16	21	9	8	3	1	3	4	6	2
Shreveport, La.	43	2	0	4	2	8	4	4	1	0	1	3	2
Spokane, Wash.	33	1	1	1	1	0	1	3	0	1	2	1	5
Tampa, Fla.	24	2	6	1	1	1	3	1	0	3	3	0	2
Washington, D. C.	27	9	14	13	5	7	2	2	3	2	2	4	6
Wichita, Kansas	26	13	12	27	33	16	14	7	6	5	7	15	4
Williston, N. D.	32	44	31	54	45	59	48	41	43	42	33	33	33

TABLE 118

TOTAL NUMBER OF THUNDERSTORMS.

STATIONS	Years record	January	February	March	April	May	June	July	August	September	October	November	December
		Abilene, Tex.	27	11	17	64	127	185	155	144	135	77	49
Albany, N. Y.	46	2	3	13	33	101	190	215	152	75	27	7	0
Alpena, Mich.	39	0	2	23	46	115	158	186	149	112	40	7	0
Birmingham, Ala.	10	10	19	28	46	75	114	133	123	71	11	9	10
Boisé, Idaho.	15	2	1	15	15	40	65	42	33	27	10	3	3
Boston, Mass.	33	4	5	11	16	47	66	106	90	44	7	6	1
Buffalo, N. Y.	43	6	6	36	55	149	176	226	170	81	47	18	4
Charleston, S. C.	43	27	57	82	134	246	421	521	467	195	57	40	26
Chicago, Ill.	19	11	12	57	109	207	252	217	134	124	50	22	3
Cincinnati, Ohio.	27	8	22	48	72	161	193	169	155	79	26	16	3
Cleveland, Ohio.	43	8	12	40	61	172	198	216	148	98	41	11	1
Denver, Colo.	31	0	1	11	36	163	261	305	230	95	10	0	0
Detroit, Mich.	43	8	12	41	87	203	241	262	185	108	53	12	1
Dubuque, Iowa.	40	5	9	51	96	206	249	250	195	148	64	19	3
Duluth, Minn.	43	2	1	14	40	121	207	247	187	109	39	4	0
Fort Smith, Ark.	31	32	42	96	159	209	234	206	205	110	63	53	13
Galveston, Tex.	28	34	56	64	100	114	125	203	219	132	55	45	38
Green Bay, Wis.	27	1	0	20	43	125	139	169	130	38	38	8	0
Havre, Mont.	32	0	0	1	12	71	183	157	134	44	0	0	0
Kansas City, Mo.	25	10	22	67	125	214	242	237	208	144	57	33	11
Knoxville, Tenn.	32	9	33	87	104	182	285	293	245	96	21	22	8
Los Angeles, Cal.	36	11	7	16	11	6	4	3	8	8	5	2	2
Memphis, Tenn.	31	30	53	106	139	174	216	240	177	85	34	41	27
New Orleans, La.	43	56	77	113	116	209	303	406	261	203	44	30	75
New York, N. Y.	30	4	7	22	50	98	160	207	157	67	21	9	2
Norfolk, Va.	30	4	15	40	68	159	183	212	185	52	17	11	5
North Platte, Neb.	39	0	0	15	75	183	286	286	220	33	20	3	0
Omaha, Neb.	41	1	7	50	120	238	301	265	225	152	72	14	5
Philadelphia, Pa.	43	2	20	41	69	156	197	272	199	81	31	15	4
Phoenix, Ariz.	17	2	8	17	12	19	23	133	168	71	14	12	3
Pittsburg, Pa.	28	11	11	42	75	146	223	238	166	87	22	5	4
Rapid City, S. D.	26	0	0	3	34	112	242	241	189	52	13	0	0
Roseburg, Ore.	36	1	0	6	9	27	17	15	13	4	1	1	1
St. Paul, Minn.	25	0	0	15	50	121	176	153	163	99	27	2	0
Salt Lake City, Utah.	38	12	8	24	43	75	96	123	169	61	28	6	3
San Francisco, Cal.	23	4	4	2	3	1	1	1	2	2	3	3	6
Santa Fé, N. M.	38	3	8	25	52	127	167	278	321	124	41	7	1
Shreveport, La.	38	38	66	109	185	203	225	264	198	109	47	39	34
Spokane, Wash.	24	2	0	2	12	31	28	32	18	4	0	0	0
Tampa, Fla.	24	28	33	54	63	156	314	393	401	210	41	9	10
Washington, D. C.	42	6	16	44	85	191	245	311	206	94	21	11	2
Wichita, Kansas.	26	4	16	56	123	224	224	226	199	140	70	14	4
Williston, N. D.	31	0	0	1	22	69	175	162	142	39	7	0	0



TABLE 119

TOTAL NUMBER OF DAYS WITH DENSE FOG.

(Fog of sufficient density to obscure buildings &c. at a distance of 1000 feet.)

STATIONS	Years record	January	February	March	April	May	June	July	August	September	October	November	December
	Abilene, Tex.	27	12	10	16	4	2	2	1	0	6	10	6
Albany, N. Y.	21	41	19	18	10	10	2	2	5	27	52	65	49
Alpena, Mich.	39	32	24	34	47	65	38	15	32	43	62	39	39
Birmingham, Ala.	10	14	6	1	4	1	2	0	1	3	3	4	5
Boise, Idaho.	15	47	9	6	2	0	1	1	1	2	0	13	40
Boston, Mass.	23	21	9	17	20	6	10	19	22	32	35	20	22
Buffalo, N. Y.	43	44	31	54	55	45	23	8	16	19	21	32	32
Charleston, S. C.	21	86	71	62	12	15	5	2	7	26	39	56	62
Chicago, Ill.	19	40	24	35	25	16	11	3	8	19	27	31	35
Cincinnati, Ohio.	20	24	22	16	12	2	2	0	4	13	39	31	25
Cleveland, Ohio.	43	21	25	32	17	3	1	4	2	11	14	10	15
Denver, Colo.	31	12	6	15	4	4	1	4	6	7	2	11	8
Detroit, Mich.	23	44	30	30	17	7	4	3	9	34	49	52	49
Dubuque, Iowa.	40	46	13	25	11	6	7	19	30	30	40	33	19
Duluth, Minn.	43	21	13	32	52	104	89	66	73	49	30	37	17
Fort Smith, Ark.	28	19	11	10	5	8	10	5	13	14	27	20	14
Galveston, Tex.	21	132	90	133	37	2	0	0	0	0	15	46	58
Green Bay, Wis.	27	24	10	27	15	13	5	5	23	22	32	26	20
Havre, Mont.	21	14	15	10	5	3	1	1	4	5	9	19	19
Kansas City, Mo.	25	44	18	26	9	7	14	13	11	16	23	25	40
Knoxville, Tenn.	32	40	29	24	14	23	21	23	76	67	122	82	39
Los Angeles, Cal.	36	44	56	86	87	96	121	150	131	145	117	66	45
Memphis, Tenn.	23	33	33	26	4	3	3	2	8	3	11	20	27
New Orleans, La.	43	142	89	98	39	14	12	16	9	7	38	90	110
New York, N. Y.	28	81	58	81	47	60	26	14	8	33	37	57	65
Norfolk, Va.	30	41	37	38	9	20	6	4	4	10	35	41	41
North Platte, Neb.	39	11	5	25	6	9	16	19	16	19	13	13	11
Omaha, Neb.	41	29	12	27	9	10	8	9	12	15	21	28	47
Philadelphia, Pa.	43	56	24	33	12	5	6	7	14	32	41	50	58
Phoenix, Ariz.	17	13	5	2	0	0	0	0	0	0	0	0	0
Pittsburg, Pa.	21	47	21	26	22	13	12	19	33	73	121	58	37
Rapid City, S. D.	26	8	3	8	8	10	3	2	5	7	7	14	10
Roseburg, Ore.	36	176	118	74	25	13	2	1	1	86	263	223	208
St. Paul, Minn.	25	15	19	11	8	5	7	2	3	23	20	28	16
Salt Lake City, Utah.	22	39	11	4	0	0	0	0	0	0	1	5	37
San Francisco, Cal.	23	55	59	29	16	16	13	44	61	46	64	67	44
Santa Fe, N. M.	38	6	3	5	4	2	2	2	2	5	5	5	6
Shreveport, La.	36	24	15	15	10	5	1	2	6	3	11	19	16
Spokane, Wash.	21	49	40	19	1	5	4	2	5	19	62	36	36
Tampa, Fla.	24	60	39	29	5	3	0	6	2	4	9	29	25
Washington, D. C.	42	74	39	44	29	16	11	6	7	30	74	83	69
Wichita, Kansas	26	58	36	25	10	3	2	9	11	12	13	24	33
Williston, N. D.	32	10	12	4	2	4	4	3	10	21	10	14	10

(3) Data on 211 storms show a sleet formation less than  $\frac{1}{4}$ " for 90 storms (42.65%); from  $\frac{1}{4}$ " to  $\frac{1}{2}$ " for 62 storms (29.39%); from  $\frac{1}{2}$ " to 1" for 42 storms (19.9%); and greater than 1" for 17 storms (8.06%).

(4) In three instances the temperature fell below zero after the sleet deposit.

(5) The maximum recorded wind velocity during 487 sleet storms occurred simultaneously with the maximum deposit of sleet in 19 instances (3.9%).

(6) The map (Fig. 429) is based on the foregoing data and the areas were determined as follows: The total number of damaging storms at each station was divided by the number of years record. The ratio thus obtained was located on the map for the station in question. The areas were then so drawn that they included:—

1st. Those stations at which the ratio was approximately 0.2 or greater. This was designated as the area in which sleet storms were frequent.

2nd. Those stations at which the ratio was approximately 0.05 to 0.2. This area was designated as the territory of occasional storms.

Some values greater than 0.05 lie outside of the territory indicated, but as they occur in isolated instances, they are not typical of the territory, therefore, the numerical value of the ratio was located rather than indicating the territory with cross-hatching.

(7) The tabulated data given are for towns and cities and do not represent the maximum conditions that may be encountered in open country.

## 15. CORRECTIONS FOR BAROMETRIC PRESSURE

b=barometric pressure at height "h" in inches.

b<sub>0</sub>=barometric pressure at sea level in inches.

h=height above sea level in feet at which barometric pressure is desired.

t=temperature in degrees F at altitude "h."

Let H=the height in meters.

Let T=the temperature in degrees C., and

Let B=the barometric pressure in millimeters.

Then, from Dr. William J. Humphreys paper on Barometric Hypsometry—final equation.

$$H=18,400 \left( \log_{10} \frac{B_0}{B} \right) \left( 1 + \frac{T_m}{273} \right)$$

But  $\frac{B_0}{B}$  is a ratio and therefore B<sub>0</sub> and B can be expressed in any units, provided the same unit is used for both.

TABLE 120  
SLEET DATA

LOCATION OF OBSERVING STATIONS	Years Record	Storm Reports	Damaging Storms	Most Severe Conditions Reported.						Number of Sleet Storms reported for Various Ice Formations				
				Maximum Recorded Sleet Deposit.			Max. Recorded Wind Velocity During Sleet Deposit.			Thickness of Ice Formation.				
				Ice Formation	Accompanying Recorded Wind Velocity	Min. Temp.	Max. Wind Velocity	Ice Formation	Min. Temp.					
										1/2	1	1-1 1/2	1 1/2 +	
Arlene, Tex.	28	2	2a	.5"	18NW	12°	23	.25"	12°	1	1			
Albany, N. Y.	40	29	29a	.5"	36		36	.5"		27b	2			
Alpena, Mich.	39	4	4s	1"	29E		48SW					2	1	
Amarillo, Tex.	22	1	1	.25"	12N		13N	.25"		1	c			
Atlanta, Ga.	36	3	3a	1"	25E	23°	30E	.5"	29°	1	1			1
Atlantic City, N. J.														
Birmingham, Ala.	14	g	0											
Bismark, N. D.	40	5	5	.5"	23W	17°	56N	.03"	3°	4	1			
Boston, Mass.	5	4	4d				45NE		27°					
Buffalo, N. Y.	20	23	23	2.8e	29NE		72SW			2e	3	3		
Chairo, Ill.	43	6	6f	2"	23		23	2"					2	
Charleston, S. C.	43	4	1	.3"	31NE		34NE	.3"						
Charlotte, N. C.	10	16	2	1"	20NE		30W	.5"		7	4	5		1
Chattanooga, Tenn.	36	1	1d	1" +	14	31.4°	14	1" +						
Chicago, Ill.	23	14	3				48NE							
Cincinnati, Ohio.	10	g	0											
Cleveland, Ohio.	43	10	10	.5"	44		47			1c				
Columbus, Ohio.	36	2	2h				32N		8°					
Concordia, Kansas.	29	5	1i	.6"	12		23	.5"	1°	3	2			
Denver, Colo.	40	4	2				27							
Des Moines, Ia.	35	10	6a				25							
Detroit, Mich.	22	1	0	.29"	40	14°	40	.29"	14°	1				
Dodge City, Kansas.	39	2	2d	3"	20	39°	31						1	
Dubuque, Ia.	39	9	9a	1.62e	31N	0°	34							
Duluth, Minn.	43	4	3		26		32	.75"	28°			1		
Eastport, Maine.	26	g	0											
Erie, Pa.	20	4	4d		42	16°	48		22°					
El Paso, Tex.	25	g	0											
Evansville, Ind.	16	13	13				20E							
Fort Smith, Ark.	31	g	0											
Galveston, Tex.	36	g	0											
Grand Haven, Mich.	24	11	11		40W		40W							
Green Bay, Wis.	27	2	0				32							
Harrisburg, Pa.	25	29	0	.5	13		40		6°	5	1	c		
Hartford, Conn.	10	g	0											
Hatteras, N. C.	40	g	0											
Havre, Mont.	33	g	0											
Huron, S. D.	32	8	1	.3"	16NE		48N							
Indianapolis, Ind.	42	3	3		26NE	24°	26NE		24°					
Kansas City, Mo.	25	17	17a	.5"	23	10°	52N		11°	1	1c			
Keokuk, Iowa.	44	14	7	1"	36W	14°	36W	1"	14°			6		
Knoxville, Tenn.	40	g	0											
Lansing, Mich.	4	g	0											
Little Rock, Ark.	24	3	3	4.3e	30	22°	20	4.3e	22°					
Louisville, Ky.	20	61	0	2.8e	36		36	2.8e	32	4	2	c		
Los Angeles, Cal.	36	g	0											

METEOROLOGICAL DATA

Sec. 11

TABLE 120—Continued

LOCATION OF OBSERVING STATIONS	Years record	Storm Reports	Damaging Storms	Most Severe Conditions Reported.						Number of Sleet Storms reported for Various Ice Formations.						
				Maximum Recorded Sleet Deposit.			Max Recorded Wind Velocity During Sleet Deposit.			Thickness of Ice Formation						
				Ice Formation	Accompanying Recorded Wind Velocity	Min. Temp.	Max. Wind Velocity	Ice Formation	Min. Temp.	1/4	1/2	1	1"	+		
Lynchburg, Va.	42	1	1a	.38"	15	31°	15	.38"	31°	c	1					
Marquette, Mich.	27	6	6	.9"	33	10°	33	.9e	10°					5		
Memphis, Tenn.	40	7	7	1.5f	16		32			1	3			c	2	
Milwaukee, Wis.	41	12	12	1"	37		40			c	1			2	2	
Nantucket, Mass.	27	4	4	1.75	33NE	27°	33NE	1.75"	27°	c						3
Nashville, Tenn.	39	7	7	.5"	37		37	.5"		2	2			c		
New Orleans, La.	40	g	0													
Norfolk, Va.	43	g	0													
North Platte, Neb.	39	3	2	.5"	14	28°	54NW		10°	c	1					
Oklahoma, Okla.	15	8	8	1"	22		32N			c	2			4		
Omaha, Neb.	41	4	4		22		30	.75"		c	1			1		
Parkersburg, W. Va.	25	3	3	1"	10NE		17	.75"		c				2		
Philadelphia, Pa.	18	5	5		30	29°	34NE		29°	c				1		
Phoenix, Ariz.	17	1	0													
Pierre, S. D.	23	g	0													
Pittsburg, Pa.	39	g	0													
Portland, Me.	42	4	4		20N		36NW			c						
Pueblo, Colo.	6	0	0							c						
Raleigh, N. C.	27	18	0		19	30°	26NE			2c						
Rapid City, S. D.	26	g	0													
Rochester, N. Y.	40	3	3	1"	40	32°	40	1"	32°					3		
Roseburg, Oregon	36	1	0													
San Francisco, Cal.	42	g	0													
Salt Lake City, Utah	38	g	0													
Sandusky, Ohio	37	5	5	1.5e			36	.5		c	2			1	1	
Santa Fé, N. M.	40	g	0													
Soranton, Pa.	14	2	2		29		29			c						
Shreveport, La.	16	1	1	.2	17	18°	18	.2	18°	c						
Sioux City, Ia.	25	13	13		55		55									
Spokane, Wash.	33	g	0													
Springfield, Ill.	35	12	12	2.33	30		30	2.33		c	6				2	
Springfield, Mo.	25	9	9	1"	30		33	.25"		2c	2			1		
St. Paul, Minn.	22	g	0													
Syracuse, N. Y.	12	3	3		18NE		52S			c						
Tampa, Fla.	34	g	0													
Toledo, Ohio	23	4	4	1"	26	28°	40NE			c						
Washington, D. C.	26	18	k	10.4e	15		34			c	2					
Wichita, Kansas	26	3	3	2.5e	23NW		30N			c						
Williston, N. D.	35	g	0													
Wilmington, N. C.	20	3	3	1"	18		30	3.4						3		

(a) Damage to telephone and telegraph wires and poles. (b) Probable thickness ranging from 1/4" to 1/2" of ice. (c) Data incomplete as regards thickness of ice. (d) Damage to telephone, telegraph and electric wires. (e) This thickness was the ice and snow deposit on the ground and not on wires for which there is no data. (f) Damage to telephone and telegraph wires. (g) Report practically no sleet damage. (h) 200 telegraph poles down 30 miles southeast of city in one of these storms. (i) One (1) inch of ice formed on telephone wires and 100 poles broken at Miltonvale, 20 miles southeast of station. (j) Estimated. (k) No records. (l) Not government records (obtained by consulting officials of Telephone and Telegraph Companies.

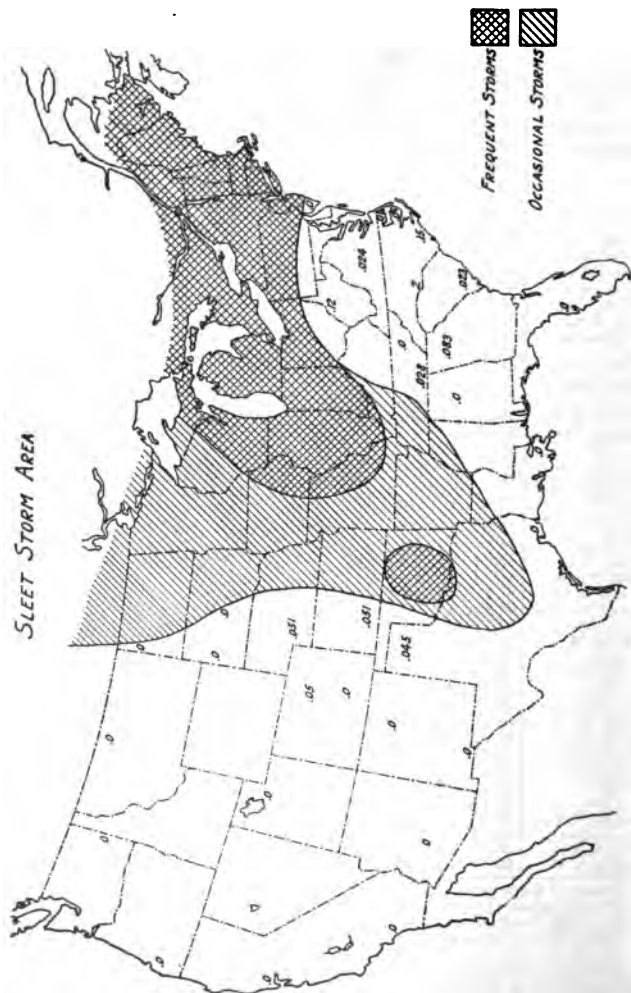

FIG. 429.—Sleet map.

Therefore,

$$H = 18,400 \left( \log_{10} \frac{b_0}{b} \right) \left( 1 + \frac{T_m}{273} \right) \text{ and,}$$

$$\log_{10} b = \log_{10} b_0 - \frac{H}{18,400 \left( 1 + \frac{T_m}{273} \right)}$$

But  $h = 3.28 H$ , and numerically,  $T_m = 5/9 (t_m - 32)$ .

Hence,

$$\log_{10} b = \log_{10} b_0 - \frac{\frac{h}{3.28}}{18,400 \left( 1 + \frac{5/9 (t_m - 32)}{273} \right)}$$

$$\log_{10} b = \log_{10} b_0 - \frac{h}{56,422 + 122.8 t_m}$$

**Problem No. 1.**

Find the equivalent sea level barometric pressure at an altitude of 6000 feet when the temperature is 60° F. assuming the reading of the barometer is 24.5''.

TABLE 121 WIND VELOCITIES, AS INDICATED BY A ROBINSON ANEMOMETER, CORRECTED TO TRUE VELOCITIES.										
Indicated Velocity.	+0	+1	+2	+3	+4	+5	+6	+7	+8	+9
0						5.1	6.0	6.9	7.8	8.7
10	9.6	10.4	11.3	12.1	12.9	13.8	14.6	15.4	16.2	17.0
20	17.8	18.6	19.4	20.2	21.0	21.8	22.6	23.4	24.2	24.9
30	25.7	26.5	27.3	28.0	28.8	29.6	30.3	31.1	31.8	32.6
40	33.3	34.1	34.8	35.6	36.3	37.1	37.8	38.5	39.3	40.0
50	40.8	41.5	42.2	43.0	43.7	44.4	45.1	45.9	46.6	47.3
60	48.0	48.7	49.4	50.2	50.9	51.6	52.3	53.0	53.8	54.5
70	55.2	55.9	56.6	57.3	58.0	58.7	59.4	60.1	60.8	61.5
80	62.2	62.9	63.6	64.3	65.0	65.7	66.4	67.1	67.8	68.5
90	69.2									

## Sec. 11 GALVANIZING AND SHERARDIZING

### Solution:

From Table 122 for 6000 feet and 60° F. find the correction factor per 100 feet elevation = 0.084.

$$\text{The total correction is } \frac{6000}{100} \times 0.084 = 5.04''.$$

$$\text{Sea level barometric pressure} = 24.5'' + 5.04'' = 29.54''.$$

### Problem No. 2.

Find the barometric pressure at an altitude of 6500 feet when the temperature is 50° F. assuming the sea level barometric pressure is 29.92''.

### Solution:

From Table 122 for 6500 feet and 50° F. find the correction factor per 100 feet elevation = 0.085.

$$\text{The total correction is } \frac{6500}{100} \times 0.085 = 5.525''.$$

$$\text{The barometric pressure is } 29.92 - 5.525 = 24.395''.$$

### Problem No. 3.

Find the barometric pressure at an altitude of 10,000 feet when the temperature is 50° F. assuming a sea level pressure of 29.92''.

### Solution:

$$\log_{10} b = \log_{10} b_0 - \frac{h}{56,422 + 122.8 t}$$

$$\log_{10} 29.92 = 1.47596$$

$$\log_{10} b = 1.47596 - \frac{10,000}{56,422 + 122.8 \times 50}$$

$$\log_{10} b = 1.31612.$$

$$b = 20.707''$$

**16. HOT GALVANIZING.** This process consists in covering wrought iron, cast iron, or steel with a coating of melted zinc. To insure perfect contact between the zinc and the metal it is necessary to remove all paint, grease, etc., by the use of benzine or a similar solvent.

In preparing cast iron the metal is further cleansed by hydrofluoric acid to remove the sand. In preparing wrought iron, a pickling solution of sulphuric acid is used, and the surface then scratch-brushed to remove scale. It may sometimes be necessary to remove certain oils with caustic potash. The cleansed material is dipped in muriatic acid and after having been thoroughly dried is dipped in melted zinc at a temperature of about 800° F. When thoroughly coated the articles are withdrawn through clean metal, where the flux has been skimmed back, and then drained and cooled in a tank of running water. The finished surface should be clean, smooth and free from blisters and dross.

**TABLE 122**  
**BAROMETRIC CORRECTIONS.**

Height in Feet.	Height in inches, corresponding to changes of 100 feet in altitude.											
	-20°	-10°	Zero.	10°	20°	30°	40°	50°	60°	70°	80°	90°
Sea level.	0.128	0.125	0.122	0.119	0.117	0.114	0.112	0.110	0.108	0.106	0.104	0.102
500 feet.	.122	.120	.117	.115	.113	.111	.109	.108	.106	.104	.102	.100
1000 "	.122	.120	.118	.115	.113	.110	.108	.106	.104	.102	.100	.098
1500 "	.120	.117	.115	.112	.110	.108	.106	.104	.102	.100	.098	.096
2000 "	.118	.115	.113	.110	.108	.106	.104	.102	.100	.098	.096	.094
2500 "	.115	.112	.110	.108	.106	.104	.102	.100	.098	.096	.094	.092
3000 "	.113	.110	.108	.106	.104	.102	.100	.098	.094	.092	.090	.088
3500 "	.111	.108	.106	.104	.102	.100	.098	.096	.094	.092	.090	.088
4000 "	.108	.106	.104	.102	.100	.098	.096	.094	.092	.090	.088	.086
4500 "	.106	.104	.102	.100	.098	.096	.094	.092	.090	.088	.086	.084
5000 "	.014	.102	.100	.098	.096	.094	.092	.090	.088	.086	.084	.082
5500 "	.100	.098	.096	.094	.092	.090	.088	.086	.084	.082	.081	.080
6000 "	.098	.096	.094	.092	.090	.088	.086	.084	.082	.081	.080	.079
6500 "	.098	.096	.094	.092	.090	.088	.086	.084	.082	.081	.080	.079
7000 "	.097	.095	.093	.091	.089	.087	.085	.084	.082	.081	.080	.078

**AVERAGE VALUES.**

Sea Level Barometric Pressures { Fair, 30.90  
Average, 29.82  
Stormy, 29.00



## Sec. 11 GALVANIZING AND SHERARDIZING

**17. SHERARDIZING.** Sherardizing is the process whereby a film of zinc dust is deposited on iron or steel. To insure perfect contact between the zinc and the article to be sherardized, it is necessary to pickle iron or steel in sulphuric acid and cast or malleable iron in hydrofluoric acid to remove the sand. After pickling the articles are boiled in hot water to remove the acid and then dried. When thoroughly dry, the material to be sherardized is placed in a drum containing loose zinc dust. The drum is not completely filled and on being rotated allows the material to shift about in the drum thus bringing all the metallic surfaces in contact with the zinc dust. The drums are heated to a temperature of about 750° F. during the six or eight hours that this process continues. The zinc coats the surface and alloys with the iron for a small distance below the surface. After sherardizing the article should have a smooth gray color.

### 18. SPECIFICATION FOR GALVANIZING IRON OR STEEL.\*

These specifications give in detail the test to be applied to galvanized material. All specimens shall be capable of withstanding these tests.

**a—Coating.** The galvanizing shall consist of a continuous coating of pure zinc of uniform thickness, and so applied that it adheres firmly to the surface of the iron or steel. The finished product shall be smooth.

**b—Cleaning.** The samples shall be cleaned before testing, first with carbons, benzine or turpentine, and cotton waste (not with a brush), and then thoroughly rinsed in clean water and wiped dry with clean cotton waste.

The samples shall be clean and dry before each immersion in the solution.

**c—Solution.** The standard solution of copper sulphate shall consist of commercial copper sulphate crystals dissolved in cold water, about in the proportion of 36 parts, by weight, of crystals to 100 parts, by weight, of water. The solution shall be neutralized by the addition of an excess of chemically pure cupric oxide (Cu O). The presence of an excess of cupric oxide will be shown by the sediment of this reagent at the bottom of the containing vessel.

The neutralized solution shall be filtered before using by passing through filter paper. The filtered solution shall have a specific gravity of 1.186 at 65 degrees Fahrenheit (reading the scale at the level of the solution) at the beginning of each test. In case the filtered solution is high in specific gravity, clean water shall be added to reduce the specific gravity to 1.186 at 65° F. In case the filtered solution is low in specific gravity, filtered solution of a higher specific

---

\* Standard National Electric Light Association Specification.

gravity shall be added to make the specific gravity 1.186 at 65 degrees Fahrenheit.

As soon as the stronger solution is taken from the vessel containing the unfiltered neutralized stock solution, additional crystals and water must be added to the stock solution. An excess of cupric oxide shall always be kept in the unfiltered stock solution.

**d—Quantity of Solution.** Wire samples shall be tested in a glass jar of at least two (2) inches inside diameter. The jar without the wire samples shall be filled with standard solution to a depth of at least four (4) inches. Hardware samples shall be tested in a glass or earthenware jar containing at least one-half ( $\frac{1}{2}$ ) pint of standard solution for each hardware sample.

Solution shall not be used, for more than one series of four immersions.

**e—Samples.** Not more than seven wires shall be simultaneously immersed, and not more than one sample of galvanized material, other than wire, shall be immersed in the specified quantity of solution.

The samples shall not be grouped or twisted together, but shall be well separated so as to permit the action of the solution to be uniform upon all immersed portions of the samples.

**f—Test.** Clean and dry samples shall be immersed in the required quantity of standard solution in accordance with the following cycle of immersions.

The temperature of the solution shall be maintained between 62 and 68 degrees Fahrenheit at all times during the following test.

First—Immerse for one minute, wash and wipe dry.

Second—Immerse for one minute, wash and wipe dry.

Third—Immerse for one minute, wash and wipe dry.

Fourth—Immerse for one minute, wash and wipe dry.

After each immersion the samples shall be immediately washed in clean water having a temperature between 62 and 68 degrees Fahrenheit, and wiped dry with cotton waste.

In the case of No. 14 galvanized iron or steel wire, the time of the fourth immersion shall be reduced to one-half minute.

**g—Rejection.** If after the test described in Section "f" there should be a bright metallic copper deposit upon the samples, the lot represented by the samples shall be rejected.

Copper deposits on zinc or within one inch of the cut end shall not be considered causes for rejection.

In the case of a failure of only one wire in a group of seven wires immersed together, or if there is a reasonable doubt as to the copper deposit, two check tests shall be made on these seven wires, and the lot reported in according with the majority of the set of tests.

**Note:—**The equipment necessary for the tests herein outlined is as follows:

Filter paper.

Commercial copper sulphate crystals.

Chemically pure cupric oxide (Cu O).

Running water.

Warm Water or ice as per needs.

Carbona, benzine or turpentine.

Glass jars at least 2 inches inside diameter by at least 4½ inches high.

Glass or earthenware jars for hardware samples.

Vessel for washing samples.

Tray for holding jars of stock solution.

Jars, bottles and porcelain basket for stock solution.

Cotton waste.

Hydrometer cylinder, 3 inches diameter by 15 inches high.

Thermometer with large Fahrenheit scale correct at 62 and 68 degrees.

Hydrometer correct at 1.186 at 65 degrees Fahrenheit.

### 19. CONCRETE.\*

**Cement:**—The production of Portland Cement in this country is now so standardized that any brand of Portland Cement will pass the standard tests provided the cement in question is a representative sample of the maker's output. The chief usefulness of the specifications is therefore to secure the proper quality rather than to discriminate between brands. It should not be understood that all cement is necessarily satisfactory, since any particular lot may have been injured by an error in manufacture; or improper or overlong storage. Any reputable manufacturer can and does make a satisfactory cement, and the cement tests should therefore be used to guard against error. The manipulation of the tests and the requirements to be met by the cement have been very completely standardized, in what are known as the Standard Specifications for Cement, copies of which may be obtained from any cement manufacturer, or from the Association of Portland Cement Manufacturers, Philadelphia, Pa.

**Proportions:**—The proportions of cement, sand and stone, or gravel will depend somewhat upon the purpose for which the concrete is to be used. In general, the smaller the volume and the greater the stresses, the richer the concrete should be. Further, if the concrete is to be impervious to water or to be immersed in water or deposited through water, the mixture should be richer, i.e. with a larger amount of cement, than would otherwise be necessary. Concrete is more impervious, permanent and stronger when it is of the maximum density, and the maximum density obtainable from any given sand, cement and stone, or gravel, will be that due to one certain proportion of the ingredients. The proper proportions in any particular case will be determinable by tests designed to disclose the voids in the aggregates which should be completely

---

\* From Pole and Tower Lines by R. D. Coombs.

filled by the sand and the cement. Ordinarily however, it is not necessary to make such tests, as the customary proportions combined with good workmanship will produce a satisfactory result. The amounts of sand and stone have usually been given separately, although in reality there should be two proportions, that of the cement and that of the combined sand and stone. The most commonly used proportions are: 1 : 6 (1 : 2 : 4) for fine work, and (1 : 9) (1 : 3 : 6) for mass foundations, etc.

**Aggregates:**—The aggregates, which are the sand, gravel, broken stone, slag, cinders, chats, etc. may be of various sizes from screenings to fairly large stones. They should however, be of graded sizes in order to present fewer voids. Inasmuch as concrete is in reality an artificial stone, its constituent parts must be free from vegetable matter and soft particles, or the resulting product will be in the nature of "rotten rock." It is frequently specified that the sand and other aggregates shall be clean, although a small percentage of clay is generally permissible, since neither sand nor gravel will be perfectly clean without very thorough washing. It has also been required that the broken stone shall be sharp, but this is generally not necessary since a high grade of concrete may be made with gravel, and gravel is never sharp. Sharp sand, however, is desirable.

**Water:**—The water used in mixing concrete should be free from oils, acids, or any very considerable amount of alkali or vegetable matter. Satisfactory water is very generally obtained throughout the country, and usually near the site of the work. Although, "dry" concrete has been used to a considerable extent abroad, and was formerly used somewhat in this country,—the present practice is to use "wet concrete." By wet concrete is meant concrete mixed with sufficient water to be semi-fluid, so that it may readily flow around the reinforcing or encased material, and be easily tamped or puddled so as to completely fill out the forms, and obtain an efficient adherence to the reinforcing, etc. The only objection to the use of an excess of water is that some of the cement will be washed away or deposited separately, and that the resulting concrete sets and dries more slowly, delaying the work. Since the water is needed both for fluidity, and for chemical combination, a sufficient quantity must be provided to prevent its absorption by, or drying on, the aggregates. In warm weather particularly, it is desirable to thoroughly wet down the pile of stone from which the material is taken.

**Mixing and Placing:**—Concrete may be mixed either by hand or by mechanical mixers, the method in any instance depending upon the quantity to be made, and the availability of a mixer at the site. Machine mixing is probably more thoroughly done than hand mixing, although just as good concrete can be made by hand under proper supervision. In hand mixing, the materials should be mixed upon a flat form or floor, in order to prevent an undue loss of cement bearing water, or the admixture of earth, etc.

Mixing floors are of various sizes from about 6 feet square up to much larger areas, but in any case it is desirable that tongue and grooved lumber, or two layers of lumber, be used in order to prevent excessive leakage through the cracks. In order to obtain the proper proportions, some unit of measurement such as a bucket or a wheelbarrow should be used to transport the aggregates from the stock pile to the mixing platform. It is then a simple matter for the workman to regularly take so many units of sand, another number of units of stone, and the specified number of bags of cement to make each batch of concrete. The sand and stone are first placed upon the mixing board and mixed by turning the pile over with shovels; the cement is then spread over the mass which is turned, water being added during the turning. The number of turns to be given each process, and the faithfulness with which the work is done determines the excellence of the mixing. Mixing should be continued until the mass presents a uniform appearance, and the stone appears to be all covered with sand and cement. As soon as the mixing is completed, the material should be taken in water tight buckets or barrows, and placed in the work. The size of the batch should depend upon the amount that can be immediately used, since material left on the board for any considerable time takes an initial set, and is useless for future work.

The placing of the concrete material should be as nearly continuous as practicable in order to prevent cleavage planes or planes of little coherence at the points where one day's work joins another. Such surfaces will contain a layer of "dead" material as well as a certain amount of dirt which floats on the surface, and in poor grades of work the joint can be distinctly seen on the sides of the structure. Since it is not always possible to work continuously, the temporary surface should be left rough and must be thoroughly washed and preferably scrubbed before continuing operations. Reinforced concrete poles should always be made in one operation as they are entirely too small to justify the risks attendant on non-continuous work.

# **SECTION 11**

**PART II**

---

## **RULES FOR RESUSCITATION FROM ELECTRIC SHOCK**

**Recommended by  
Commission on Resuscitation from  
Electric Shock**

**Representing  
The American Medical Association  
The National Electric Light Association  
The American Institute of Electrical Engineers**

**Issued by  
NATIONAL ELECTRIC LIGHT ASSOCIATION  
Engineering Societies Building  
New York**

## RESUSCITATION FROM ELECTRIC SHOCK

SUPERINTENDENTS, FOREMEN AND OTHERS HAVING CHARGE OF MEN, ARE ADVISED TO GIVE PRACTICAL INSTRUCTIONS AND DEMONSTRATIONS ON THE USE OF THESE RULES TO ALL OLD AND NEW EMPLOYEES.

PHYSICIANS WHO MAY BE CALLED UPON IN CASES OF SHOCK SHOULD BE GIVEN COPIES OF THESE INSTRUCTIONS, AND WHERE PRACTICABLE, PLACED IN COMMUNICATION WITH THE PHYSICIAN OF THE ELECTRICAL COMPANY.

The prone-pressure method of artificial respiration described in these rules (Section III) is equally applicable, after clearing the mouth and throat of froth, to resuscitation of the apparently drowned, and also to cases of suspended respiration due to inhalation of gas or to other causes.

---

### COMMISSION ON RESUSCITATION FROM ELECTRIC SHOCK

- DR. W. B. CANNON, *Chairman*  
*Professor of Physiology, Harvard University*
- DR. GEORGE W. CRILE  
*Professor of Surgery, Western Reserve University*
- DR. YANDELL HENDERSON  
*Professor of Physiology, Yale University*
- DR. S. J. MELTZER  
*Head of Department of Physiology and Pharmacology, Rockefeller Institute for Medical Research*
- DR. EDW. ANTHONY SPITZKA  
*Director and Professor of General Anatomy, Daniel Baugh Institute of Anatomy, Jefferson Medical College*
- MR. W. C. L. EGLIN  
*Past-President, National Electric Light Association*
- DR. A. E. KENNELLY  
*Professor of Electrical Engineering, Harvard University*
- DR. ELIHU THOMSON  
*Electrician, General Electric Company*
- MR. W. D. WEAVER, *Secretary*  
*Editor, Electrical World*

## TREATMENT FOR ELECTRIC SHOCK

An accidental electric shock usually does not kill at once, but may only stun the victim and for a while stop his breathing.

The shock is not likely to be immediately fatal, because:

(a) The conductors may make only a brief and imperfect contact with the body.

(b) The skin, unless it is wet, offers high resistance to the current. Hope of restoring the victim lies in prompt and continued use of artificial respiration. The reasons for this statement are:

(a) The body continuously depends on an exchange of air, as shown by the fact that we must breathe in and out about fifteen times a minute.

(b) If the body is not thus repeatedly supplied with air, suffocation occurs.

(c) Persons whose breathing has been stopped by electric shock have been reported restored after artificial respiration has been continued for approximately two hours.

The Schäfer, or "prone pressure" method of artificial respiration, slightly modified, is illustrated and described in the following resuscitation rules. The advantages of this method are:

(a) Easy performance; little muscular exertion is required.

(b) Larger ventilation of the lungs than by the supine method.

(c) Simplicity; the operator makes no complex motions and readily learns the method on first trial.

(d) No trouble from the tongue falling back into the air passage.

(e) No risk of injury to the liver or ribs if the method is executed with proper care.

Aid can be rendered best by one who has studied the rules and has learned them by practice on a volunteer subject.

---

## INSTRUCTIONS FOR RESUSCITATION

**Follow these Instructions Even if Victim Appears Dead.**

### I.—BREAK THE CIRCUIT IMMEDIATELY

1. With a single quick motion separate the victim from the live conductor. In so doing avoid receiving a shock yourself. Many have, by their carelessness, received injury in trying to disconnect victims of shock from live conductors.

#### Observe the Following Precautions

(a) Use a dry coat, a dry rope, a dry stick or board, or any other **dry non-conductor** to move either the victim or the wire, so as to break the electrical contact. Beware of using metal or any moist material. The victim's loose clothing, if dry, may be used to pull





FIG. 430.—Inspiration; pressure off.



FIG. 431.—Expiration; pressure on.

him away; do not touch the soles or heels of his shoes while he remains in contact—the nails are dangerous.

(b) If the body must be touched by your hands, be sure to cover them with rubber gloves, mackintosh, rubber sheeting or dry cloth; or stand on a dry board or on some other dry insulating surface. If possible, use only one hand.

If the victim is conducting the current to ground, and is convulsively clutching the live conductor, it may be easier to shut off the current by lifting him than by leaving him on the ground and trying to break his grasp.

2. Open the nearest switch, if that is the quickest way to break the circuit.

3. If necessary to cut a live wire, use an ax or a hatchet with a dry wooden handle, or properly insulated pliers.

### II.—SEND FOR THE NEAREST DOCTOR

This should be done without a moment's delay, as soon as the accident occurs, and while the victim is being removed from the conductor.

### III.—ATTEND INSTANTLY TO VICTIM'S BREATHING

(1) As soon as the victim is clear of the live conductor, quickly feel with your finger in his mouth and throat and remove any foreign body (tobacco, false teeth, etc.). Then begin artificial respiration at once. Do not stop to loosen the patient's clothing; every moment of delay is serious.

(2) Lay the subject on his belly, with arms extended as straight forward as possible, and with face to one side, so that the nose and mouth are free for breaching (see Figure 430). Let an assistant draw forward the subject's tongue.

If possible, avoid so laying the subject that any burned places are pressed upon.

Do not permit bystanders to crowd about and shut off fresh air.

(3) Kneel straddling the subject's thighs and facing his head; put the palms of your hands on the loins (on the muscles of the small of the back), with thumbs nearly touching each other, and with fingers spread over the lowest ribs (see Figure 430.)

(4) With arms held straight, swing forward slowly so that the weight of your body is gradually brought to bear upon the subject (see Figure 431). This operation, which should take from two to three seconds, must not be violent—internal organs may be injured. The lower part of the chest and also the abdomen are thus compressed, and air is forced out of the lungs.

(5) Now immediately swing backward so as to remove the pressure, but leave your hands in place, thus returning the position shown in Figure 430. Through their elasticity, the chest walls expand and the lungs are thus supplied with fresh air.

(6) After two seconds swing forward again. Thus repeat de-

liberately twelve to fifteen times a minute the double movement of compression and release—a complete respiration in four or five seconds. If a watch or a clock is not visible, follow the natural rate of your own deep breathing—swinging forward with each expiration, and backward with each inspiration.

While this is being done, an assistant should loosen any tight clothing about the subject's neck, chest, or waist.

(7) Continue artificial respiration (if necessary, two hours or longer), without interruption, until natural breathing is restored, or bags filled with warm (not hot) water. The attention to keeping until a physician arrives. Even after natural breathing begins, carefully watch that it continues. If it stops, start artificial respiration again.

During the period of operation, keep the subject warm by applying a proper covering and by laying beside his body bottles or rubber the subject warm should be given by an assistant or assistants.

(8) Do not give any liquids whatever by mouth until the subject is fully conscious.

#### First Care of Burns

When natural respiration has been restored, burns, if serious, should be attended to until a doctor comes.

A raw or blistered surface should be protected from the air. If clothing sticks, do not peel it off—cut around it. The adherent cloth, or a dressing of cotton or other soft material applied to the burned surface, should be saturated with picric acid (0.5 per cent.). If this is not at hand, use a solution of baking soda (one teaspoonful to a pint of water), or the wound may be coated with a paste of flour and water. Or it may be protected with a heavy oil, such as machine oil, transformer oil, vaseline, linseed, carron or olive oil. Cover the dressing with cotton, gauze, lint, clean waste, clean handkerchiefs, or other soft cloth, held lightly in place by a bandage.

The same coverings should be lightly bandaged over a dry, charred burn, but without wetting the burned region or applying oil to it.

Do not open blisters.



# INDEX

	A	PAGE		PAGE
Abrasion Molding.....		713	Alternating Current, Single-Phase,	
Absolute Temperature, Definition..		3	Three-Wire System, Description	443
A. C. Lightning Arrester Grounds..		433	Single-Phase System, Two-	
Single-Phase, Three-Wire Sys-			Wire, Description of.....	443
tem, Calculation.....		477	Two-Phase, Four-Wire System	455
Single-Phase System, Calcula-			Two-Phase, Three-Wire Sys-	
tion.....		474	tem, Description.....	443
Single-Phase, Vector Diagram		454	Alternation, Definition.....	3
Series System, Calculation..		482	Periodicity of, Definition.....	4
Series System, Description.....		450	Alternating Current Power, Defini-	
Systems, Method of Calcula-			tion.....	4
tion.....		460	Aluminum, Definition.....	4
Three-Phase, Three-Wire Sys-			Cables, Weatherproof Insu-	
tem, Description.....		445	lated, Specification for.....	257
Three-Phase System, Calcula-			Cell Lightning Arresters.....	403
tion.....		478	Location of Ores.....	179
Three-Phase, Four-Wire Sys-			Reduction of.....	178
tem, Description.....		448	Refining of.....	179
Three-Phase System, Vector			Aluminum Wire, Bare, Specifica-	
Diagram.....		457	tion for.....	257
Three - Phase, Transformer			Copper Equivalent, Table of..	247
Connections.....		448	Loading Table.....	541
Two-Phase, Three-Wire Sys-			Special Sizes, Table of.....	247
tem, Calculation.....		477	Table of Physical Constants..	185
Two-Phase, Three-Wire Sys-			Weatherproof Insulated, Spec-	
tem, Vector Diagram.....		456	ification.....	257
Two-Phase, Four-Wire Sys-			American Wire Gauge, Definition	
tem, Description.....		445	of.....	4
Additions to Existing System, Cal-			Amount of Oil Necessary for Creos-	
culation.....		481	oted Pine Poles.....	635
Additions, Vector.....		454	Ampere, Definition.....	5
Admittance, Definition.....		3	Hour, Definition.....	5
Aerial Cable, Definition.....		3	Second, Definition.....	5
Conductor, Definition.....		3	Turn, Definition.....	5
Line Construction, Specifica-			Turns, Secondary, Definition..	47
tions.....		674-749	Amplitude of Vibration of Wave,	
Ageing of Transformer Core, Defi-			Definition.....	5
nition.....		3	Analysis Specification, Coal-Tar	
Ageing of Transformer Steel..		321-337	Creosote.....	624
Insulators.....		298	for Mixed Oils, Wood Preser-	
Agents, Preservative.....		585	vation.....	629
Air-Break Switches.....		413	Water-Gas-Tar Creosote.....	629
Air-Core Transformer, Definition..		3	Anchor Guys.....	704
Air-Gap, Definition.....		3	Guy, Locating Foot of.....	706
Air-Path, Definition.....		3	Log, Definition.....	5
Air-Reluctance, Definition.....		3	Anchor, Patented Guy.....	284
Allerdyce Process of Wood Preser-			Angle of Lag or Lead of Current,	
vation.....		601	Definition of.....	5
Alphabet, Greek.....		57	Angle, Phase, Definition.....	43
Alternate Hot and Cold Treat-			Angular Velocity, Definition of...	5
ment, Wood Preservation.....		605	Annual Service Charge.....	660
Alternating Current, Definition..		3, 441	Apparent Efficiency, Definition..	5
Five-Wire System, Two-Phase,			or Equivalent Resistance, Defi-	
Description.....		445	nition of.....	6

# INDEX

PAGE	PAGE
Apparent Power, Definition.....	5
Application of Rubber Compound.....	182
Arbor Vites Logging.....	111, 112
Time of Cutting.....	111
Where Grown.....	111
Arc Lamp Cut-outs.....	414
Areas of Circles, Tables of.....	95-99
Armor of Cable, Definition of.....	6
Arresters, Aluminum Cell Light-	
ning.....	403
Compression Lightning.....	397
Electrolytic Lightning.....	403
Grounding of Lightning.....	409
Horn.....	409
Lightning, Definition.....	38
Lightning Installation of.....	745
Lightning, Location of.....	407
Multi-gap Lightning.....	397
Multipath Lightning.....	406
Pole Line.....	398
Single Gap Lightning.....	404
Artificial Foundation For Poles.....	687
Asbestos, Definition of.....	6
Attaching Insulators to Pins.....	278
Pins to Cross-arms.....	278
Axis of Co-ordinates, Definition.....	6
Auto Transformers, Definition.....	6, 319
Automatic Circuit-Breaker, Defini-	
tion.....	6
Switch, Definition.....	6
Auxiliary Specification, Wood Pres-	
ervation.....	630
<b>B</b>	
Back Yard, Rights-of-Way.....	683
Balanced Circuit, Definition.....	6
Balanced Load of System, Defini-	
tion.....	6
Bare, Hard-Drawn Copper Wire, Specification.....	252
Barometric Corrections, Table of.....	783
Pressure, Corrections for.....	777
Barrow-Reel, Definition.....	7
Beg-Ohms, Definition.....	7
Bends in Line, Calculation of Pole Strength.....	557
Bending Moment Formulæ, Table of.....	526
Formulæ.....	523
Bethel Process of Wood Preserva-	
tion.....	597
Bicro, Definition.....	7
Bight of Cable, Definition.....	7
Bimetallic Wire, Definition.....	7
Blowing a Fuse, Definition.....	7
Blowing Point of Fuse, Definition.....	7
Bolts, Carriage.....	279
Cross-arm.....	279
Specification for Carriage.....	279-281
Specification for Cross-arm.....	279-281
Booster Transformer, Calculation of Capacity.....	504
Braces, Attaching to Pole.....	690
Cross-arm.....	278
Braces, Specifications for Cross-arm	
Bracing of Buck-arms.....	279
of Cross-arms.....	695
Flexible Towers, Function of.....	161
of Steel Poles, Function of.....	155
of Steel Towers, Function of.....	155
Brackets, Poles.....	284
Bracket Saddle, Definition.....	47
Braided Wire, Definition.....	7
Branch Circuits, Definition.....	7
Cut-out, Definition.....	7
Lines.....	720
Breaker, Circuit, Definition.....	10
Breaking Down of Insulation, Defini-	
tion.....	7
Strength of Wires, Solid, Table of.....	215
Strength of Wires, Stranded, Table of.....	216
Britannia Joint, Definition.....	7
Bronze, Definition.....	7
Browne & Sharpe Gauge, Law of.....	196
Brush Combined with Open Tank Treatment, Wood Preserva-	
tion.....	610
and Spray Discharge, Defini-	
tion.....	7
Treatment, Wood Preserva-	
tion.....	650
Buck-Arms.....	693
bracing of.....	695
Buck-Arm Gains.....	681
Bunched Cable, Definition of.....	7
Burnett Process of Wood Preserva-	
tion.....	600
Butt Rot.....	123
<b>C</b>	
Cable, Aerial, Definition.....	3
Aluminum, Weatherproof Insulated, Specification.....	257
Armor of, Definition.....	6
Bight of, Definition.....	7
Capacity of, Definition.....	9
Casing, Definition.....	8
Concentric, Definition.....	11
Copper, Weatherproof Insulated, Specification.....	251
Core, Definition.....	8
Definition.....	8
Duplex, Definition.....	8, 18
Grip, Definition.....	8
House, Definition.....	8
Lead Encased.....	36
Paper, Definition.....	41
Submarine, Definition.....	8
Vault, Definition.....	8
Calculation of A. C. Systems.....	469
of Additions to Existing Systems.....	481
Characteristics, Suspension Insulators.....	308
of D. C. Series System.....	469
of D. C. Two-Wire System.....	464

# INDEX

PAGE	
Calculation of Dead End Loading of Poles	556
of Edison Three-Wire System	469
of Guying	557
of Pole Strength, Bends in Line	557
of Pole Stresses	549
of Regulators, Capacity	503
of Regulation, Voltage Regulators	501
of Stresses on Cross-arms	547
of Single Phase, Three-Wire System	477
of Single-Phase, Two-Wire System	474
of Strength of Rotted Poles	553
of Three-Phase System	478
of Transformer Capacity	494
of Transformer Efficiency	500
of Transformer Regulation	498
of Two-Phase, Three-Wire System	477
of Two-Wire D. C. Railway System	466
Capacity of Cable, Definition	9
Carrying, Definition	9
Condenser, Definition	12
Dielectric, Definition	17
Distributed, Definition	17
Electrostatic, Definition	9, 20
Electrostatic, Unit of, Definition	9
Formula for	463
of Line, Definition	9
Reactance, Definition	9
Solid Wire, Table of	226
Stranded Wire, Table of	228
Suspension Insulators	304
of Suspension Insulators, Grading of	311
of Transformer, Calculation of	494
Cap Wire, Definition	8
Carbon, Definition	9
Card Process of Wood Preservation	600
Carriage Bolts	279
Bolts, Specification for	279-281
Carrying Capacity, Definition	9
Cartridge Fuses	422
Cases, Transformer	324
Casing, Cable, Definition of	8
Cat Faces	124
Catenary Curve, Definition	9
Cedar, Western Red, Absorption of Creosote	662
Western Red, Tank Treatment with Creosote	661
Cell, Electrolytic, Definition	20
Cement, Insulator	295
Insulator, Property of	295
Cementing Together, Built-up Insulators	294
Center of Distribution, Definition	9, 17
of Distribution, Locating of	490
Centigramme, Definition	9

PAGE	
Centimeter, Definition	9
Centimeter-Gramme-Second System, Definition	9
Characteristic Curve, Definition	9
Characteristics, Transformer	345
Charging Current, Effect on Line	460
Calculation	460
Solid Wire, Table of	238
Stranded Wire, Table of	244
Charge, Electric, Definition	10
Charges on Transmission Lines, Electric Causes	393
Chestnut Poles, Dimensions of	126
Logging of	112
Poles, Specification for	125
Time of Cutting	113
Where Grown	112
Choke Coils	411
Coil, Definition	10, 319
Choice of Preservatives, Wood Preservation	619
of Voltage on Transmission Line	484
Circuit, Balanced, Definition	7
Branch, Definition	6
Breaker, Automatic, Definition	6
Breaker, Definition	10
Constant-Potential, Definition	12
Earth, Definition	18
Electric, Definition	10
Ground, Definition	24
High Tension, Definition	32
Inductive, Definition	33
Leg of, Definition	36
Multiple, Definition	10, 39
Multiple-Series, Definition	39
Open, Definition	10, 41
Parallel, Definition	10
Polyphase, Definition	44
Series, Definition	10
Series-Multiple, Definition	48
Short, Definition	48
Circular Mil, Definition	10
Circumferences of Circles, Tables of	95-99
Clays for Porcelain Insulators	289
Clearing Obstacles, by Pole Line	685
Clockwise Motion, Definition	10
Coal-Tar Creosote	587
Creosote, Analysis Specification	624
Creosote, Production of	587
Creosote, Specification	621
Coefficient of Expansion, Definition	10
Hysteresis, Definition	11, 32
of Mutual Inductance, Definition	11
of Self-Inductance, Definition	11
Temperature	193, 194
Temperature, Definition	51
Temperature, Table of	192-194
Coils, Choke	411



# INDEX

PAGE	PAGE
Coils, Choke, Definition .....	10, 319
Flat Formed .....	323
Impedance, Definition .....	32
Inductance, Definition .....	33
Primary of Transformer, Definition .....	44
Reactance, Definition .....	319
Tertiary .....	382
Transformer .....	321
Cold Preservative, Steeping in .....	602
Waves .....	760
Colorie, Definition .....	8
Coloring of Glass, Porcelain, Insulators .....	291
Come Along, Definition .....	11
Combination Pins .....	274
Common Logarithms, of Numbers .....	50-83
Return, Definition .....	11
Comparative Weight of Conductors, Electrical System .....	450
Comparison of Oil Preservatives .....	595
of Resistance Units .....	189
of Strength, Steel Poles and Steel Towers .....	159
of Y and "Δ" Transformer Connections .....	450
of Wire Gauges .....	195
of Wood Preservative .....	664
Compensator, Definition .....	11, 319
Complete Wave, Definition .....	11
Components of Impedance, Definition .....	11
Composite Wire, Definition .....	11
Composition Insulators .....	296
Compound, Application of Rubber Definition .....	182
Compressed Gas Expulsion Fuse .....	428
Compression Lightning Arresters and Tension Formulas .....	397
Concentric Cable, Definition .....	523
Winding .....	11
Concrete, Description of .....	323
Pole, Flexibility of .....	786
Poles, Forms for .....	141
Poles, Handling of .....	136
Poles, Hollow .....	141
Poles, Hollow, Method of Manufacture .....	141, 142
Poles, Mixture of Concrete .....	139
Poles, Molding of .....	140
Poles, Reinforced .....	135
Poles, Solid .....	135, 136
Poles, Steel Reinforcing .....	136
Poles, Strength of Concrete .....	139
Strength of .....	139
Condenser, Definition .....	12
Capacity, Definition .....	12
Conductance, Definition .....	12
Conductivity, Electric, Definition .....	12
Matthiessen's Standard .....	190
Relative .....	190
Relative, Table of .....	191
Specific .....	190
Specific, Definition .....	49
Conductors .....	177
Aerial, Definition .....	3
Definition .....	12
Negative, Definition .....	39
Neutral, Definition .....	39
Overhead, Definition .....	41
Sag of, Definition .....	47
Stranded, Definition .....	50
Connecting Single-Phase Load to Polyphase Systems .....	498
Sleeve, Definition .....	12
Connection, Multiple, Definition .....	12
Series, Definition .....	12
Testing of Ground .....	433
Constant, Definition .....	12
Current, Definition .....	12
Current Transformers, Definition of .....	12, 319
Potential Circuit, Definition .....	12
Voltage Transmission .....	511
Construction, Transformer .....	319
Consumer's Services .....	745
Continuous Current, Definition .....	13, 439
Convection Currents, Definition .....	13
Convective Discharge, Definition .....	13
Conversion Tables .....	102-104
Co-ordinates, Axis of, Definition .....	6
Co-periodic, Definition .....	13
Co-Phase, Definition .....	13
Copper, Definition .....	13
Cables, Weatherproof Insulated, Specifications for .....	251
Clad Billets, Production of .....	180
Clad, Steel Wire, Hard-Drawn Specification .....	254
Clad Wire, Internal Inductance of .....	247
Clad Wire, Table of Physical Constants .....	186
Location of Ore .....	177
Loss, Definition .....	13
Loss Tests, Induction Regulators .....	386
Losses, Transformers .....	330
Loss Test, Transformers .....	359
Reduction of .....	177
Refining of .....	177
Wire, Current Carrying Capacity, Table of .....	204
Wire, Hard-Drawn, Definition .....	26
Wire, Hard-Drawn, Specification .....	252
Wire, Loading Table .....	538
Wire, Soft Drawn, Definition .....	49
Wire, Stranded, Bare Loading Table .....	538
Wire, Specifications for Weather-proof Insulated .....	251
Wire, Table of Physical Constants .....	18-4
Core, Cable, Definition .....	8
Lamination of, Definition .....	13
Laminated, Definition .....	36
Losses, Definition .....	13

# INDEX

	PAGE		PAGE
Core Loss Test, Transformers	355	Cross-arms, Special	270
Transformer	320	Specification for	267
Type Transformers	320	Specifications for Creosoting	
Corner Poles, Wiring of	720	Pine	638
Corona and Corona Loss	484	Storing	566
Definition	13	Steel	270
Corrections for Barometer, Table		Treating Plants, Open Tank,	
of	783	Description of	644
for Barometric Pressure	777	Cross, Electric, Definition	14
for Wind Velocities, Table of	781	Crossings, Street	683
Cosine, Definition	13	Cross-section Area, B. & S. Gauge,	
Co-Tangent, Definition	14	Table of	196
Coulomb, Definition	14	Cruciform Type Transformers	321
Counter-Electromotive-Force, Defi-		Curb Line, Location of Poles	685
nition	14	Current, Alternating, Definition	3, 441
of Induction, Definition	14	Alternating, Series System,	
Couple, Definition	14	Description	450
Creosote, Coal-Tar	587	Carrying Capacity, Copper	
Coal-Tar, Analysis Specifica-		Wire, Table of	204
tion	624	Constant, Definition	12
Coal-Tar, Specification	621	Continuous, Definition	13
Oil for Brush Treatment, Spec-		Convection, Definition	13
ification	633	Density of, Definition	16
Water-Gas-Tar	592	Determination from Wattage,	
Water-Gas-Tar, Specification		Definition	14
of	629	Distribution, Definition	14
Wood	594	Earth, Definition	18
Creosoted Pine Cross-arms, Speci-		Electric, Definition	14
fication of	270	Energy Component of, Defi-	
Creosoted Pine Poles, Specifica-		nition	21
tion for	634	Fusing, Definition	23
Yellow Pine Poles, Dimen-		Foucault, Definition	15
sions of	134	Harmonic, Definition	26
Yellow Pine Poles, Specifica-		Heating Effects of	200
tion for	134	High Potential, Definition	32
Creosoting Pine Cross-arms, Speci-		Induced, Definition	33
fication	638	Lagging, Definition	36
Pine Poles, Amount of Oil		Leading, Definition	36
Necessary	635	Mean, Definition	38
Pine Poles, Specification	635	Normal, Definition	40
Crib Bracing for Poles	686	Oscillatory, Definition	41
Cross-arms	267	Polyphase, Definition	15, 44
Bolts	279	Primary, Definition	45
Bolts, Specification for	279-281	Pulsating, Definition	45
Braces	278	Rush, Definition	15
Bracing	690	Secondary, Definition	47
Braces, Specifications for	279	Simple Periodic, Definition	15
Buck	693	Stray, Definition	50
Calculation of Stresses	547	Strength of, Definition	15, 50
Creosoted Pine Specifications		Table of Fusing Effects	199
for	637	Table of Heating Effects	202
Definition	14	Curve, Catenary, Definition	9
Double	692	Characteristic, Definition	9
Equipping with Insulators	695	Characteristic, Transformer	345
Fitting to Poles	690	Sinusoidal, Definition	49
Gains	681	Cut-out, Arc Lamp	414
Guys	709	Definition	16
Location of	691	Block, Definition	16
Method of Attaching Pins	278	Branch, Definition	7
Painting and Treating	690	Single-pole, Definition	49
Pins	695	Switch, Definition	16
Preservative Treatment of	581	Cycle, Definition of	16, 441
Seasoning	585	Hysteretic, Definition	32
Size	690		
Size to Use	690		

# INDEX

<b>D</b>			
	PAGE	PAGE	
Dead End Loading of Poles, Calculations of.....	556	Direct Current, Three-Wire System, Description.....	440
Man, Definition.....	16	Three-Wire System, Method of Calculating.....	469
Desay of Wood.....	583	Two-Wire System, Method of Calculating.....	464
Decimal Equivalents, Table of.....	94	Two-Wire System, Description.....	439
Defects, Wood Poles.....	123	Discharge, Definition.....	17
Definition Regulators.....	319	Convective, Definition.....	13
Transformers.....	319	Disruptive, Definition.....	17
of Transmission and Distribution Systems.....	439	Electrostatic, Definition.....	20
Deflection Formula, Table of.....	528	Static, Definition.....	50
Delta-Connection, Definition.....	16	Surging, Definition.....	50
Delta Three-Phase System, Definition.....	16	Disruptive Discharge, Definition.....	17
Demand, Definition.....	16	Strength of Dielectric, Definition.....	17
Factor, Definition.....	16	Dissipation of Energy, Definition.....	17
Density, Definition.....	16	Distributed Capacity, Definition.....	17
of Current, Definition.....	16	Inductance, Definition.....	17
of Field, Definition.....	16	Distributing Mains, Definition.....	18
Surface, Definition.....	50	Systems, Description of.....	439
Description of Open Tank Plants.....	641	Distribution, Center of, Definition.....	9, 17
of Vectors.....	452	Current, Definition.....	14
Design-Transformers.....	333	Locating the Center of.....	490
Determination of Current from Wattage, Definition.....	14	Series, Definition.....	48
Devices, Grounding.....	432	Systems of.....	722
Diagrams, Vector.....	451	Diversity Factor, Definition.....	18
Vector, Definition.....	53	Draw Vise, Definition.....	18
Diameter of Wire, Brown & Sharpe Gauge.....	196	Drawing Wire.....	181
of Wire, Solid, Table of.....	217	Drop, Definition.....	18
of Wires, Stranded, Table of.....	218	Ohmic, Definition.....	40
Dielectric, Definition.....	16	of Potential, Definition.....	18
Capacity, Definition.....	17	Reactive, Definition.....	45
Disruptive Strength of, Definition.....	17	of Voltage, Definition.....	18
Hysteresis, Definition.....	17	Dry Process, Porcelain Insulators.....	291
Resistance, Definition.....	17	Duplex Cable, Definition.....	18
Strain, Definition.....	17	Duplex Wire, Definition.....	18
Strength, Transformer Insulation.....	346	Dynamic Electricity, Definition.....	18
Difference, Phase, Definition.....	43	Dyne, Definition.....	18
Dimensions of Chestnut Poles.....	126	<b>E</b>	
of Creosoted Yellow Pine Poles.....	134	Earth Circuit, Definition.....	18
of Eastern White Cedar Poles.....	127	Currents, Definition.....	18
of Idaho Cedar Poles.....	130	Easement, Definition.....	18
of Red Cedar Poles.....	130	Eastern White Cedar Poles, Dimensions of.....	127
of Sawed Red Wood Poles.....	132	Specification for.....	127
of Western Cedar Poles.....	130	Economics of Transmission.....	506
of Western White Cedar Poles.....	130	Eddy Currents, Definition.....	19
of Yellow Pine Poles.....	133	Losses-Transformers.....	329
Dipping, Definition.....	17	Edison Three-Wire System, Description.....	440
Direct Current, Definition of.....	439	Method of Calculating.....	469
Railway, System, Description.....	439	Effect of Charging Current on Line Calculation.....	460
Railway System, Method of Calculating.....	466	of different types of pins on Insulator characteristics.....	297
Series Lighting System, Description.....	440	of Ground, Definition.....	24
Series System, Method of Calculating.....	469	Effects of Higher Harmonics, Definition.....	29
Series System, Thury, Description.....	440	Effect, Page, Definition.....	41
		Skin, Definition.....	49

# INDEX

PAGE		PAGE
<p>Effective Capacity Suspension Insulators..... 304</p> <p>Electromotive-Force, Definition..... 19</p> <p>Mechanical Stress on Insulators..... 296</p> <p>Reactance, Definition..... 19</p> <p>Resistance..... 205</p> <p>Resistance, Definition..... 19</p> <p>Efficiency, Apparent, Definition of..... 5</p> <p>Efficiency, Definition..... 19</p> <p>Transformers..... 335</p> <p>Transformer, Calculation of..... 500</p> <p>Elastic Limit, Definition..... 19</p> <p>Elasticity, Modulus of, Definition..... 39</p> <p>Electro Charge, Definition..... 10</p> <p>Charges on Transmission Lines, Causes..... 303</p> <p>Circuit, Definition..... 10</p> <p>Conductivity, Definition..... 12</p> <p>Cross, Definition..... 14</p> <p>Current, Definition..... 14</p> <p>Energy, Definition..... 21</p> <p>Gradient, Definition..... 23</p> <p>Horse-Power, Definition..... 32</p> <p>Insulator, Definition..... 34</p> <p>Potential, Definition..... 44</p> <p>Quantity, Definition..... 45</p> <p>Shock, Resuscitation from..... 789</p> <p>Surging, Definition..... 50</p> <p>Transmission, Definition..... 52</p> <p>Wave, Definition..... 55</p> <p>Electrical Characteristics of Insulators..... 297</p> <p>Systems, Comparative Weight of Conductor..... 450</p> <p>Tests on Insulators..... 299-301</p> <p>Electricity, Dynamic, Definition..... 18</p> <p>Static, Definition..... 50</p> <p>Electrification, Definition..... 19</p> <p>Electro-chemistry, Definition..... 19</p> <p>Electrolysis, Definition..... 20</p> <p>Electrolyte, Definition..... 20</p> <p>Electrolytic Cell, Definition..... 20</p> <p>Lightning Arresters..... 403</p> <p>Electro-Magnetic Units, Definition..... 19</p> <p>Electro-Metallurgy, Definition..... 19</p> <p>Electro-Motive Force, Effective, Definition..... 19</p> <p>Energy Component of, Definition..... 21</p> <p>Impressed, Definition..... 33</p> <p>Electro-Motive Forces, Induced, Definition..... 33</p> <p>Mean, Definition..... 38</p> <p>Electro-Motive Force, Primary, Definition..... 45</p> <p>Reactive, Definition..... 46</p> <p>Wattless Component of, Definition..... 55</p> <p>Electro-Negative, Definition..... 19</p> <p>Ions, Definition..... 20</p> <p>Electro-plating, Definition..... 20</p> <p>Electro-positive, Definitions..... 20</p> <p>Ions, Definition..... 20</p>	<p>Electrostatic Capacity, Definition..... 8, 20</p> <p>Unit of, Definition of..... 9</p> <p>Electrostatic Discharge, Definition..... 20</p> <p>Field, Definition..... 20</p> <p>Force, Definition..... 20</p> <p>Induction, Definition..... 20</p> <p>Lines of Force, Definition..... 20</p> <p>Potential, Definition..... 20</p> <p>Units, Definition..... 20</p> <p>Enclosed Fuses..... 422</p> <p>Energy, Definition..... 20</p> <p>Component of Current, Definition..... 21</p> <p>Component of Electro-Motive Force, Definition..... 21</p> <p>Dissipation of, Definition..... 17</p> <p>Electric, Definition..... 21</p> <p>Potential, Definition..... 44</p> <p>Equaliser Feeder, Definition..... 21</p> <p>Equations, Transformer..... 327</p> <p>Equipotential, Definition..... 21</p> <p>Equivalents, Decimal, Table of..... 94</p> <p>Equivalent Resistance, Definition of..... 6</p> <p>Resistance, Definition..... 21</p> <p>Resistance and Reactance of Transformers..... 332</p> <p>Erg, Definition..... 21</p> <p>Exciting Current, Transformers..... 330</p> <p>Test Transformers..... 355</p> <p>Existing Systems, Calculations for Additions to..... 481</p> <p>Expansion, Coefficient of, Definition..... 10</p> <p>Expulsion Type Fuse..... 426</p> <p>Extra Galvanised Steel Strands, Table of..... 213</p>	
	<b>F</b>	
	<p>Factor, Demand, Definition..... 16</p> <p>Diversity, Definition..... 18</p> <p>Reactance, Definition..... 45</p> <p>Reactive, Definition..... 46</p> <p>Fahrenheit Thermometric Scale, Definition..... 21</p> <p>Failure of Insulators..... 298</p> <p>Structural Steel Poles..... 151</p> <p>Structural Steel Towers..... 151</p> <p>Farad, Definition..... 21</p> <p>Fatigue of Iron or Steel, Magnetic, Definition..... 21</p> <p>Magnetic, Definition..... 37</p> <p>Feed, Definition..... 21</p> <p>Feeder, Definition..... 21</p> <p>Distribution, Definition..... 21</p> <p>Equaliser, Definition..... 21</p> <p>Feeders, Negative, Definition..... 39</p> <p>Neutral, Definition..... 39</p> <p>Feeding Point, Definition..... 22</p> <p>Field, Density of, Definition..... 16</p> <p>Electrostatic, Definition..... 20</p> <p>Magnetic, Definition..... 37</p> <p>Resultant Magnetic, Definition..... 47</p>	

# INDEX

PAGE	PAGE		
Field, Stray, Definition . . . . .	50	Fusing Current, Definition . . . . .	23
Fire Killed Poles, Western Red Cedar . . . . .	117	Effects of Current, Table . . . . .	199
Firing and Glazing Porcelain Insulators . . . . .	291	<b>G</b>	
Five-Wire, Two-Phase System, Description . . . . .	445	Gains, Buck-Arm . . . . .	681
Flat Formed Coils . . . . .	323	Cross-arm . . . . .	681
Flexible Towers . . . . .	160	Definitions . . . . .	23
Function of Bracing . . . . .	161	Galvanised Steel Strand, Specifications for . . . . .	251
Flexibility of Concrete Poles . . . . .	141	Galvanising, Definitions . . . . .	23
Flux, Magnetic, Definition . . . . .	37	Hot, Description of . . . . .	782
Paths, Magnetic, Definition . . . . .	37	Specification for . . . . .	784
Foot-Pound, Definition . . . . .	22	Gauge, American Wire, Definition of . . . . .	4
Per-Second, Definition . . . . .	22	Brown & Sharpe, Law of . . . . .	196
Force, Electrostatic, Definition . . . . .	20	Gauges of Wire, Comparison of Wire . . . . .	195
Lines of, Definition . . . . .	36	Gauss, Definition . . . . .	23
Magnetic, Definitions . . . . .	37	German Government Report—Wood Preservation . . . . .	664
Magnetizing, Definition . . . . .	38	Gilbert, Definition . . . . .	23
Forms for Concrete Poles . . . . .	136	Glass Insulators . . . . .	293
Formulas for Bending Moment . . . . .	523	Cementing Together Parts . . . . .	294
for Capacity . . . . .	463	Glazing and Firing Porcelain Insulators . . . . .	291
for Compression and Tension . . . . .	523	Insulator, Properties of . . . . .	293
for Inductance . . . . .	463	Globe Strain, Insulators, Definition . . . . .	23
for Line Supports at Different Levels . . . . .	529	Gradient, Electric, Definition . . . . .	23
for Resultant Load on Wire . . . . .	527	Grading Capacity of Suspension Insulators . . . . .	311
for Shearing . . . . .	523	Graphical Solution of Three-phase Transmission Lines . . . . .	479
for Torsion . . . . .	524	Graphite, Definition . . . . .	23
for Weight of Wire and Ice . . . . .	527	Greek Alphabet . . . . .	57
for Wind Pressure . . . . .	523	Grip, Cable, Definition . . . . .	8
for Wind Pressure on Wires . . . . .	527	Ground, Definition . . . . .	24
Foucault Current, Definition . . . . .	15	Circuit, Definition . . . . .	24
or Eddy Currents, Definition . . . . .	22	Connections, Testing of . . . . .	433
Four-Wire, Three-Phase System, Description . . . . .	448	Effect of, Definition . . . . .	24
Two-Phase System, Description . . . . .	445	Pipe . . . . .	429
Frequency, Definition . . . . .	441	Return, Definition . . . . .	24
Fundamental, Definition . . . . .	23	Secondary . . . . .	433
High, Definition . . . . .	31	Stub . . . . .	162
Fundamental Frequency, Definition . . . . .	23	Water Pipe . . . . .	433
Units . . . . .	102-104	Wires on Transmission Lines . . . . .	411
Function of Bracing, Flexible Towers . . . . .	161	Grounding . . . . .	428
of Bracing Steel Poles . . . . .	155	Devices . . . . .	432
of Bracing Steel Towers . . . . .	155	of Lightning Protective Apparatus . . . . .	409
Periodic, Definition . . . . .	41	of Transformer Cases . . . . .	433
Fuse . . . . .	417	Gutta-Percha, Definition . . . . .	25
Block, Definition . . . . .	23	Guys, Anchor . . . . .	704
Blocks, Installation . . . . .	736	Guy Anchor, Locating Foot of . . . . .	706
Blowing a, Definition . . . . .	7	Anchors, Patented . . . . .	284
Blowing Point of, Definition . . . . .	7	Anchor Protection . . . . .	706
Box, Definition . . . . .	23	Attachments . . . . .	701
Compressed Gas Expulsion . . . . .	428	Clearance . . . . .	709
Cartridge . . . . .	422	Guys, Cross-arm . . . . .	709
Electric, Definition . . . . .	23	Guy, Definition . . . . .	25
Enclosed . . . . .	422	Fittings . . . . .	701
Expulsion Type . . . . .	426	Insulation . . . . .	709
Link . . . . .	420	Guys, Pole, Definition . . . . .	44
Links, Definition . . . . .	23		
Oil-Immersed . . . . .	425		
Safety, Definition . . . . .	47		

# INDEX

PAGE	PAGE
Guy Rods.....	282
Rods, Specification for.....	282-284
Guys, When to Use on Poles.....	695
When to Use Two Guys.....	706
Guy Wire, Definition.....	25
Wire.....	212, 701
Guying, Calculation of.....	557
Corner Poles.....	697
Curved Lines.....	697
to Iron Poles.....	709
Long Spans.....	695
Poles on Hills.....	701
Straight Lines.....	695
Stub.....	701
Terminal Poles.....	695
to Trees.....	706
<b>H</b>	
Hail Storms.....	767
Hall Effect, Definitions.....	25
Handling of Concrete Poles.....	141
Hard-drawn, Copper Clad, Steel Wire, Specification for.....	254
Copper Wire, Definition.....	26
Copper Wire, Specifications for.....	252
Harmonic Currents, Definition.....	26
Harmonics, Effects of Higher, Defi- nition.....	29
H. B. Curves, Definition.....	25
Heart Rot.....	123
Wood.....	582
Heat, Definition.....	31
Mechanical Equivalent of, Definition.....	38
Unit, Definition.....	31
Heating Effects of Currents.....	200
of Current, Table of.....	202
Heating Test, Regulators.....	385
Transformers.....	350
Heavy Poles.....	685
Height of Poles.....	681
Henry, Definition.....	31
High Frequency, Definition.....	31
Potential Current, Definition.....	32
Potential Insulator, Defini- tion.....	32
Tension Circuit, Definition.....	32
Hollow Concrete Poles, Method of Manufacture.....	141
Poles.....	141
Horn Arresters.....	409
Horse-Power, Definition.....	32
Electric, Definition.....	32
Hour, Definition.....	32
Hot Galvanizing, Description of.....	782
Treatment, Wood Preserva- tion.....	602
Waves.....	762
Hydro-Electric System, Definition.....	32
Hysteresis, Coefficient of, Defini- tion.....	11, 32
Definition.....	32
Dielectric, Definition.....	17
Hysteretic Cycle, Definition.....	32
Lag, Definition.....	32
Losses, Transformers.....	329
<b>I</b>	
Ice Storms.....	767
Idaho Cedar, Specifications for.....	129
Poles, Dimensions of.....	130
Impedance Coils, Definition.....	32
Components of, Definition.....	11
Definition.....	32
Tests, Induction Regulators.....	386
Impressed Electromotive Force, Definition.....	33
India-Rubber, Definition.....	33
Induced Current, Definition.....	33
Electromotive Forces, Defini- tion.....	33
M. M. F., Definition.....	33
Voltage, Transformers.....	331
Inductance Coil, Definition.....	33
Definition.....	33
Distributed, Definition.....	17
Formulas for.....	463
Induction, Definition.....	33
Counter-Electromotive-Force of, Definition.....	14
Electrostatic, Definition.....	20
Magnetic, Definition.....	33
Mutual, Definition.....	33, 39
Regulators, Description.....	379
Self, Definition.....	33
Inductive Capacity, Specific, Defi- nition.....	49
Circuits, Definition.....	33
Reactance, Definition.....	34, 45
Reactance, Solid Wire, Table of.....	229
Reactance, Stranded Wire, Table of.....	235
Ingot, Working of.....	181
Ions, Electro Negative, Definition.....	20
Positive, Definitions.....	20
In-put, Definition.....	34
Installation of Fuse Blocks.....	736
Installation of Transformers.....	729
Installing Pole Steps.....	687
Instantaneous Peak, Definition.....	34
Insulate, Definition.....	34
Insulated Wires, Definition.....	34
Insulating Joint, Definition.....	34
Varnish, Definition.....	34
Insulation, Breaking Down of, Definition.....	7
of Guy Wire.....	709
Induction Regulators, Testing of.....	385
Moisture-Proof, Definition.....	39
Protection of Rubber.....	183
Resistance, Definition.....	34
Rubber.....	181
Transformers.....	334
Transformer, Testing of.....	345
Weatherproof.....	181

# INDEX

PAGE		PAGE	
<p>Insulation, Weatherproof, Definition . . . . . 55</p> <p>Insulator Cement . . . . . 294</p> <p style="padding-left: 20px;">Property of . . . . . 295</p> <p>Insulator Characteristics, Effect of Different Types of Pins on . . . . . 297</p> <p style="padding-left: 20px;">Clays . . . . . 289</p> <p style="padding-left: 20px;">Electric, Definition . . . . . 34</p> <p style="padding-left: 20px;">Failures . . . . . 298</p> <p style="padding-left: 20px;">Glazing, Properties of . . . . . 293</p> <p style="padding-left: 20px;">High-potential, Definition . . . . . 32</p> <p style="padding-left: 20px;">Manufacture . . . . . 291</p> <p style="padding-left: 20px;">Petticoat, Definition . . . . . 42</p> <p style="padding-left: 20px;">Pin, Definition . . . . . 35</p> <p style="padding-left: 20px;">Pins, Wood, Specification for . . . . . 272, 273</p> <p style="padding-left: 20px;">Protection . . . . . 301</p> <p style="padding-left: 20px;">Strain, Definition . . . . . 50</p> <p>Suspension, Calculated Characteristics . . . . . 308</p> <p>Suspension, Effective capacity . . . . . 304</p> <p>Suspension, Grading Capacity of . . . . . 311</p> <p>Suspension, Voltage Distribution, Dry Arc-over . . . . . 311</p> <p>Suspension, Voltage Distribution, Wet-Arc-Over . . . . . 311</p> <p style="padding-left: 20px;">Tests . . . . . 299</p> <p style="padding-left: 20px;">for Trees . . . . . 713</p> <p style="padding-left: 20px;">Triple Petticoat, Definition . . . . . 53</p> <p>Insulators, Ageing of . . . . . 298</p> <p style="padding-left: 20px;">Cementing together, built-up . . . . . 294</p> <p style="padding-left: 20px;">Composition . . . . . 296</p> <p style="padding-left: 20px;">Effect of Mechanical Stress on . . . . . 296</p> <p style="padding-left: 20px;">Electrical Characteristics of . . . . . 297</p> <p style="padding-left: 20px;">Glass . . . . . 293</p> <p style="padding-left: 20px;">Glass, Cementing together parts . . . . . 294</p> <p style="padding-left: 20px;">Installing on Cross-Arms . . . . . 695</p> <p style="padding-left: 20px;">Method of Attaching to Pins . . . . . 278</p> <p style="padding-left: 20px;">Pin Type . . . . . 289</p> <p style="padding-left: 20px;">Porcelain . . . . . 289</p> <p style="padding-left: 20px;">Porcelain, Coloring of Glaze . . . . . 291</p> <p style="padding-left: 20px;">Porcelain, Dry Process . . . . . 291</p> <p style="padding-left: 20px;">Porcelain, Glazing and Firing . . . . . 291</p> <p style="padding-left: 20px;">Porcelain, Wet Process . . . . . 291</p> <p style="padding-left: 20px;">Strain . . . . . 289</p> <p style="padding-left: 20px;">Suspension . . . . . 289</p> <p>Intensity, Magnetic, Definitions . . . . . 37</p> <p>Interleaved Winding . . . . . 323</p> <p>Internal Inductance of Wire . . . . . 247</p> <p>Iron Core Loss, Definition . . . . . 35</p> <p style="padding-left: 20px;">Location of Ore . . . . . 179</p> <p style="padding-left: 20px;">and Steel, Location of Ore . . . . . 180</p> <p style="padding-left: 20px;">or Steel, Magnetic Fatigue of, Definition . . . . . 21</p> <p style="padding-left: 20px;">and Steel, Reduction of . . . . . 180</p> <p style="padding-left: 20px;">and Steel, Refining of . . . . . 180</p> <p style="padding-left: 20px;">Loss, Voltmeter . . . . . 356</p> <p style="padding-left: 20px;">Loss Tests, Induction Regulators . . . . . 386</p> <p style="padding-left: 20px;">Poles, Guying to . . . . . 709</p> <p style="padding-left: 20px;">Wire, Table Physical Constants . . . . . 188</p>	<h2 style="margin: 0;">J</h2> <p>Jackets, or Butt Settings, Wood Preservation . . . . . 610</p> <p>Joints, Britannia, Definition . . . . . 7</p> <p>Joint, Insulating, Definition . . . . . 34</p> <p style="padding-left: 20px;">Sleeve, Definition . . . . . 49</p> <p>Joule, Definition . . . . . 35</p> <p>Joule's Law of Heating, Definition . . . . . 35</p> <p>Jumper, Definition . . . . . 35</p>	<h2 style="margin: 0;">K</h2> <p>Kaolin, Definition . . . . . 35</p> <p>Kilo, Definition . . . . . 35</p> <p>Kilovolt, Definition . . . . . 35</p> <p style="padding-left: 20px;">Ampere, Definition . . . . . 35</p> <p>Kilowatt, Definition . . . . . 35</p> <p style="padding-left: 20px;">Hour, Definition . . . . . 36</p> <p>Knife-Switch, Definition . . . . . 36</p>	<h2 style="margin: 0;">L</h2> <p>Lagging Current, Definition . . . . . 36</p> <p>Lag, Hysteretic, Definition . . . . . 32</p> <p style="padding-left: 20px;">Screws . . . . . 279</p> <p style="padding-left: 20px;">Screws, Specification for . . . . . 279-281</p> <p>Laminated Core, Definition . . . . . 13, 36</p> <p>Lamination of Core, Definition . . . . . 13</p> <p style="padding-left: 20px;">Definition . . . . . 36</p> <p>Law of the Brown &amp; Sharpe Gauge of Heating, Joule's Definition . . . . . 35</p> <p>Lead, Definition . . . . . 36</p> <p style="padding-left: 20px;">Encased Cable, Definition . . . . . 36</p> <p>Leading Current, Definition . . . . . 36</p> <p>Leakage Reactance, Definition . . . . . 36</p> <p>Leg of Circuit, Definition . . . . . 36</p> <p>Lenz's Law, Definition . . . . . 36</p> <p>Life of Poles, Comparison of Preservatives . . . . . 664</p> <p>Lightning Arrester, Definition . . . . . 36</p> <p style="padding-left: 20px;">Arresters, Aluminum Cell . . . . . 403</p> <p style="padding-left: 20px;">Arresters, Compression . . . . . 397</p> <p style="padding-left: 20px;">Arresters, Electrolytic . . . . . 403</p> <p style="padding-left: 20px;">Arrester Grounds (A-C) . . . . . 433</p> <p style="padding-left: 20px;">Arresters, Grounding of . . . . . 409</p> <p style="padding-left: 20px;">Arresters, Installation of . . . . . 745</p> <p style="padding-left: 20px;">Arresters, Location of . . . . . 407</p> <p style="padding-left: 20px;">Arresters, Low Equivalent . . . . . 397</p> <p style="padding-left: 20px;">Arresters, Multigap . . . . . 397</p> <p style="padding-left: 20px;">Arresters, Multipath . . . . . 406</p> <p style="padding-left: 20px;">Arrester, Single Gap . . . . . 404</p> <p style="padding-left: 20px;">Phenomena . . . . . 393</p> <p style="padding-left: 20px;">Protective Apparatus . . . . . 396</p> <p style="padding-left: 20px;">Rod, Definition . . . . . 36</p> <p>Lighting System, Direct Current Series, Description . . . . . 440</p> <p>Line, Capacity of, Definition . . . . . 9</p> <p style="padding-left: 20px;">Construction, Specifications for . . . . . 674-749</p> <p>Line Hardware, Carriage Bolts . . . . . 279</p> <p style="padding-left: 20px;">Cross-arm Bolts . . . . . 279</p> <p style="padding-left: 20px;">Cross-arm Braces . . . . . 278</p> <p style="padding-left: 20px;">Guy Rods . . . . . 282-284</p> <p style="padding-left: 20px;">Lag Screws . . . . . 279</p> <p style="padding-left: 20px;">Patented Guy Anchors . . . . . 284</p>

# INDEX

	PAGE		PAGE
Line Hardware, Pole Brackets . . . . .	284	Lowry Process of Wood Preserva-	
Specification for . . . . .	279-284	tion . . . . .	601
Washers . . . . .	279		
Line Level of Pole Line . . . . .	685	<b>M</b>	
Loss Tables, Explanation of . . . . .	472	Magnetic Fatigue . . . . .	337
Supports at Different Levels, . . . . .		Fatigue, Definition . . . . .	37
Formula for . . . . .	529	Fatigue of Iron or Steel, Defi-	
Terminals . . . . .	720	nition . . . . .	21
Wire or Conductor, Sag of, . . . . .		Field, Definition . . . . .	22, 37
Definition . . . . .	47	Flux, Definition . . . . .	37
Wire Taps . . . . .	720	Flux-Paths, Definitions . . . . .	37
Lines of Force, Definition . . . . .	36	Magnetizing Force, Definition . . . . .	38
of Force, Electrostatic, Defi-		Magnetic Induction, Definition . . . . .	33
nition . . . . .	20	Intensity, Definition . . . . .	37
of Magnetisation, Definition . . . . .	36	Saturation, Definition . . . . .	37
on Private Property . . . . .	722	Units, Definition . . . . .	38
Links, Fuse, Definition . . . . .	23	Magnetism, Residual, Definition . . . . .	46
Link Fuses . . . . .	420	Magnetisation, Lines of, Definition . . . . .	36
Live Wire, Definition . . . . .	37	Mains, Definition . . . . .	38
Load, Definition . . . . .	37	Distributing, Definition . . . . .	18
Loads, Power-factors of Various . . . . .	505	Supply, Definition . . . . .	50
Types . . . . .		Three-Wire, Definition . . . . .	52
Loading of Structural Steel Poles . . . . .	149	Two-Wire, Definition . . . . .	53
of Structural Steel Towers . . . . .	149	Manufacture of Glass Insulators . . . . .	293
Table, Aluminum Wire, Strand-		Insulators, Porcelain . . . . .	291
ed, Bare . . . . .	541	Wire . . . . .	181
Table of Bare Copper Wire, . . . . .		Wire, Application of Rubber . . . . .	182
Solid . . . . .	539	Wire, Protection of Rubber . . . . .	
Table of Bare Copper Wire, . . . . .		Insulation . . . . .	183
Stranded . . . . .	538	Wire, Rubber Insulation . . . . .	181
Table, Insulated Copper Wire . . . . .	540	Wire, Vulcanizing . . . . .	182
Load-factor, Definition . . . . .	37	Wire, Weatherproof Insula-	
Loblolly Pine, Cutting of . . . . .	118	tion . . . . .	181
Logging of . . . . .	118	Wire, Wire Drawing . . . . .	181
Locating the Center of Distribu-		Wire, Working . . . . .	181
tion . . . . .	490	M. M. F. Induced, Definition . . . . .	33
Poles on Street . . . . .	683	Map, The Weather . . . . .	756
Location of Aluminum Ores . . . . .	179	Mass, Definition . . . . .	38
of Copper Ore . . . . .	177	Matthiessen's Standard Conduc-	
of Iron Ore . . . . .	179	tivity . . . . .	190
of Lightning Arresters . . . . .	407	Maximum Demand, Definition . . . . .	38
of Steps on Poles . . . . .	687	Temperatures, Table of . . . . .	
and Wiring of Lightning Pro-		Monthly Mean . . . . .	768
jective Apparatus . . . . .	407	Maxwell, Definition . . . . .	38
of Wires on Poles . . . . .	722	Mean Current, Definition . . . . .	38
Lodge Pole, Pine Poles, Logging of . . . . .	122	Mean Electromotive Force, Defi-	
Where Grown . . . . .	122	nition . . . . .	38
Logarithm, Definition . . . . .	37	Mechanical Calculation of Trans-	
of Numbers, Common . . . . .	59-83	mission and Distribution . . . . .	523-559
Logging, Chestnut . . . . .	112-114	Mechanical Equivalent of Heat, . . . . .	
of Loblolly Pine . . . . .	118	Definition . . . . .	38
of Lodge Pole Pine Poles . . . . .	122	Stress, Effect on Insulators . . . . .	296
of Western Red Cedar . . . . .	114	Tests, Insulators . . . . .	301
of Western Yellow Pine . . . . .	119	Megohm, Definition . . . . .	38
White Cedar and Arbor . . . . .	112	Mho, Definition . . . . .	38
Vita . . . . .	111	Mensuration . . . . .	102
Loop Test, Definition . . . . .	37	Messenger Rope, Definition . . . . .	38
Loss, Copper, Definition . . . . .	13	Metal Pins, Types of . . . . .	274
Corona . . . . .	484	Wood and Porcelain Pins . . . . .	274
Losses, Core, Definition . . . . .	13	Methods of Calculating Trans-	
Low Artificial Pressure System, . . . . .		mission Line Losses . . . . .	464
Wood Preservation . . . . .	607	Method of Transposing Trans-	
Equivalent Lightning Arrest-		mission Lines . . . . .	509
ers . . . . .	397		
Potential System, Definition . . . . .	37		



# INDEX

PAGE	PAGE
Metric Weights and Measures 103, 104	Oil-break Switches..... 417
Microfarad, Definition..... 38	Duct, Transformer..... 324
Microhm, Definition..... 38	Immersed Fuse..... 425
Micrometer Wire-Gauge, Definition..... 38	Open Circuit, Definition..... 10, 41
Circular, Definition..... 10	Tank Plants, Description of... 641
Foot, Definition..... 39	Tank Treatment, Creosote Oil 655
Milli-Ampere, Definition..... 39	Tank Treatment, Creosote
Definition..... 39	and Zinc Chloride..... 659
Milli-Henry, Definition..... 39	Tank Treatment, Crude Pe-
Volt, Definition..... 39	troleum..... 657
Minimum Temperature, Table of	Tank Treatment, of Pole
Monthly Mean..... 769	Butts, Specification for... 640
Mixed Oils, Wood Preservation,	Tank Treatment, Western
Specification for..... 628	Yellow Pine..... 655
Mixture of Concrete for Concrete	Tank Treatment, Wood Pres-
Poles..... 139	ervation..... 607
Modulus of Elasticity, Definition.. 39	Tank Treatment Zinc Chlor-
Moisture-Proof Insulation, Definition..... 39	ide..... 658
Molding, Abrasion..... 713	Operation, Transformer..... 366
of Concrete Poles..... 140	Ore, Location of Aluminum..... 179
Moment of Inertia Formulas, Table	Location of Copper..... 177
of..... 525	Iron..... 179
Motion, Clockwise, Definition..... 10	Oscillations and Surges, Causes... 396
Multiple Connection, Definition... 12	Oscillatory Current, Definition... 41
Circuit, Definition..... 10, 39	Outdoor Sub-stations..... 163
Multi-gap Lightning Arresters.... 397	Overhead Conductor, Definition... 41
Multiple Pipe Grounds..... 429	Over-Potential Test, Transformers 350
Series Circuit, Definition..... 39	
Multi-path Lightning Arresters.... 406	<b>P</b>
Mutual Inductance, Coefficient of,	Page Effect, Definition..... 41
Definition..... 11	Painting, Cross-Arms..... 690
Induction, Definition..... 33, 39	Poles..... 681
<b>N</b>	Pancake Winding..... 323
Natural Trigonometric Functions,	Paper Cable, Definition..... 41
Tables of..... 85-91	Paraffine, Definition..... 41
Needle Gaps, Table of Sparking	Parallel Circuit, Definition..... 10
Distances..... 513	Connecting of Transformers.. 368
Negative Conductor, Definition... 39	Patented Guy Anchors..... 284
Feeders, Definition..... 39	Steel Poles..... 147
Neutral Conductor, Definition.... 39	Peak, Definition..... 41
Feeder, Definition..... 39	Load, Definition..... 41
Non-Conductor, Definition..... 39	Percentage Conductivity..... 190
Inductive Resistance, Defini-	of Wire, Definition..... 41
tion..... 40	Periodic Function, Definition.... 41
Normal Current, Definition..... 40	Periodicity, Definition..... 41
Numbering of Poles..... 683	of, Alternation, Definition of... 4
<b>O</b>	Permittance, Definition..... 41
Obstacles, Clearing of, by Pole	Petroleum Oil for Wood Preserv-
Line..... 685	ation..... 594
Oersted, Definition..... 40	Petticoat Insulator, Definition... 42
Ohm, Definition..... 40	Phase Angle, Definition..... 43
Ohm's Law, Definition..... 40	Definition..... 42
Ohmic Resistance, Definition.... 40	Difference, Definition..... 43
Drop, Definition..... 40	Phenomena, Lightning..... 393
Oil for Preserving Wood..... 586	Physical Data..... 102
Preservatives, Comparison of... 595	Pin Threading, Standard..... 272
Transformer, Specifications of 364	Type Insulators..... 289
	Pins, Effect of High Voltage on... 297
	Combination..... 274
	Definition..... 43
	Effect of Different Types on
	Insulator Characteristics... 297
	Fitting in Cross-arms..... 695
	Insulator..... 270

# INDEX

PAGE		PAGE	
Pins, Method of Attaching to Cross-Arms.....	278	Poles, Protection of.....	687
Method of Attaching Insulators to.....	278	Red Cedar Poles, Dimensions of.....	130
Preservation of.....	297	Sawed Red Wood, Dimensions of.....	132
Specification for Wood Insulator.....	272	Seasoning.....	565
Wood.....	270-272	Setting of.....	685
Pine Cross-Arm, Creosoted, Specifications for.....	637	Setting in Quick-Sand.....	687
Cross-Arms, Specifications for Creosoting.....	638	Settings, Table of.....	685
Cross-Arms, Specifications for Creosoted.....	270	Solid Concrete.....	135, 136
Western Yellow, Annual Service Charge Wood Preservation.....	660	Spacing of.....	683
Western Yellow, Comparative Cost of Treatment.....	661	Pole Specifications.....	125
Western Yellow, Treated with Creosote.....	655	Poles, Steel.....	145
Western Yellow, Treated with Crude Petroleum.....	658	Tubular, Table of.....	146
Western Yellow, Treated with Zinc Chloride.....	659	Pole Steps.....	281
Pipe Grounds.....	429	Definition.....	44
Multiple.....	429	Installing.....	687
Resistance of.....	429	Location on Poles.....	687
Pipe, Water, Grounds.....	433	Specification for.....	281, 282
Plane Vector, Definition.....	43	Poles to be Stepped.....	687
Plants for Wood Preservation.....	597	Storing.....	566
Plating, Zinc, Definition.....	57	Pole Strength, Calculation for Bends in line.....	557
Platinum, Definition.....	44	Stresses, Calculation of.....	549
Plumbago, Definition.....	44	Poles, Structural Steel.....	148
Poles, Artificial Foundation for.....	687	Pole Treating Plants, Open Tank, Description of.....	641
Pole, Attaching Braces.....	690	Treatment, Comparative Costs.....	661
Brackets.....	284	Treatment, Western Red Cedar, Creosote.....	661
Poles, Calculation of Dead End Loading.....	556	Treatments, Western Red Cedar, Creosote and Zinc Chloride.....	664
Calculation of Rotted.....	553	Treatment, Western Yellow Pine, Open Tank.....	655
Chestnut, Dimensions of.....	126	Treatments, Western Red Cedar, Crude Petroleum.....	663
Concrete Molding of.....	140	Treatments, Western Yellow Pine, Crude Petroleum.....	658
Creosoted Yellow Pine, Dimensions of.....	134	Treatments, Western Yellow Pine, Chloride.....	659
Crib Bracing for.....	686	Treatments, Zinc Chloride, Western Red Cedar.....	663
Eastern White Cedar, Dimensions of.....	127	Poles, Trimming.....	681
Pole, Fitting Cross-Arms to.....	690	Tubular Steel.....	147
Guys, Definition.....	44	Pole Type Regulators.....	384
Guying.....	695	Wiring.....	720
Poles, Heavy.....	685	Wiring for Arc Lamps.....	748
Height of.....	681	Poles, Wiring of Corner.....	720
Hollow Concrete.....	141	Pole Wiring for Incandescent Lamps.....	749
Hollow Concrete, Method of Manufacture.....	141, 142	Poles, Western Cedar, Dimensions of.....	130
Idaho Cedar, Dimensions of.....	130	Western White Cedar Poles, Dimensions of.....	130
Pole-Line Arresters.....	397	Wood.....	111, 135
Line Level.....	685	Yellow, Pine, Dimensions of.....	133
Poles, Located in Rock.....	687	Polyphase Circuits, Definition.....	44
Locating on Street.....	683	Currents, Definition.....	15
Location of Curb Line.....	685	Definition.....	44
Location of Wires.....	722	Induction Regulators, Description.....	382
Pole Numbering.....	683	Systems, Connecting Single-Phase Load to.....	498
Poles, Painting of.....	681	Transmission, Definition.....	44
Preservative Treatment of.....	561		

# INDEX

PAGE		PAGE
	Polyphase Transformers, Description .....	367
	Porcelain, Definition .....	44
	Insulators .....	289
	Insulators, Cementing together .....	294
	Parts .....	289
	Insulator Clays .....	291
	Insulators, Coloring of Glass .....	291
	Insulators, Dry Process .....	291
	Insulators, Glazing and Firing .....	291
	Insulator Manufacture .....	291
	Insulators, Properties of Glazing .....	293
	Insulators, Relative Advantage of Wet and Dry Process .....	292
	Insulators, Wet Process .....	291
	Wood and Metal Pins .....	274
	Positive Wire, Definition .....	44
	Potential, Drop of, Definition .....	18
	Electric, Definition .....	44
	Electrostatic, Definition .....	20
	Energy, Definition .....	44
	Regulators, Definition of .....	319
	Polarity Test, Transformers .....	362
	Potential, Traveling Waves of .....	394
	Power, Alternating Current, Definition of .....	4
	Apparent, Definition of .....	5
	Definition .....	44
	Circuits, Definition .....	44
	Factor, Definition .....	44
	Factors, Resultant .....	505
	Factor Transformers .....	340
	Factors of Various Types of Load .....	505
	Preservation of Pins .....	297
	Preservative .....	578
	Agents .....	585
	Treatment of Cross-Arms .....	561
	of Wood with Oils .....	586
	Preservatives, Comparison of Oil .....	595
	Preservative Treatment of Poles .....	561
	Preserving Wood with Salts .....	594
	Primary, Definition .....	44
	Coil of Transformer, Definition .....	44
	Currents, Definition .....	45
	Electro-motive Force, Definition .....	45
	Processes for Wood Preservation .....	596
	Production of Coal-Tar Creosote .....	587
	Copper Clad Billets .....	180
	Water-Gas Creosote .....	592
	Properties of Insulator Glazing .....	293
	Special Steel Strands, Table of .....	214
	Wire Materials, Table of .....	537
	Property of Insulator Cement .....	295
	Protection of Insulators .....	301
	Poles .....	687
	Rubber Insulation .....	183
	Pulsating Current, Definition .....	45
	Quantity, Electric, Definition .....	45
	of Oil Necessary for Creosoted Pine Poles .....	635
	Vector, Definition .....	53
	Quarter Phase, Definition .....	45
	System, Definition .....	45
	Quick-Sand, Setting Poles in .....	687
	<b>R</b>	
	Radian, Definition .....	45
	Per Second, Definition .....	45
	Radius of Gyration, Table of .....	525
	Railway System, Direct Current, Description of .....	439
	Method of Calculating .....	466
	Rain Storms .....	766
	Ratio of Transformation, Definition .....	45
	Transformers .....	332
	Transformer, Test of .....	361
	Reactance, Capacity, Definition .....	9
	Coils, Definition of .....	319
	Drop, Transformers .....	360
	Effective, Definition .....	19
	Factor, Definition .....	45
	Inductive, Definition .....	34, 45
	Leakage, Definition .....	36
	Reactive Drop, Definition .....	45
	Electromotive Force, Definition .....	46
	Factor, Definition .....	46
	Reactors, Definition of .....	319
	Red Cedar Poles, Dimensions of .....	130
	Specification for .....	129
	Reduction of Aluminum Ore .....	178
	Copper .....	177
	Iron and Steel .....	180
	Steel and Iron .....	180
	Refining of Aluminum Ore .....	179
	Copper .....	177
	Iron and Steel .....	180
	Steel and Iron .....	180
	Regulation, Definition .....	46
	of Induction Regulators .....	387
	of Regulators .....	501
	of Regulators, Single-Phase System .....	501
	of Regulators, Three-Phase, Four-Wire System .....	503
	of Regulators, Three-Phase, Three-Wire System .....	502
	of Regulators, Two-Phase System .....	502
	Transformer .....	336
	Transformer Calculation of .....	498
	of Transformers, Test of .....	361
	Regulator Capacity, Calculation of .....	503
	Regulators, Induction, Description .....	379
	Pole Type .....	384
	Polyphase Induction, Description .....	382
	Potential, Definition of .....	319
	Regulation of .....	387, 501
	<b>Q</b>	
	Quadrature, Definition .....	45

# INDEX

PAGE		PAGE	
Regulators, Regulation of, Single-Phase System.....	501	Rubber Compound, Application of	182
Regulation of, Three-Phase, Four-Wire System.....	503	India, Definition.....	33
Regulation of, Three-Phase, Three-Wire System.....	502	Insulation.....	181
Regulation of Two-Phase System.....	502	Insulation, Protection of.....	183
Test of.....	385	Vulcanising.....	182
Voltage.....	501	Rules for Resuscitation from Electric Shock.....	789
Reinforced Concrete Poles.....	135	Running Wires Through Trees.....	713
Reinforcing Wires.....	721	Riping, Process of Wood Preservation.....	601
Relative Advantage of Wet and Dry Process Porcelain Insulators.....	292	Rifters Process of Wood Preservation.....	600
Conductivity.....	190		
Conductivity, Table of.....	191	<b>S</b>	
Resistance, Table of.....	191	Saddle Bracket, Definition.....	47
Reluctance, Definition.....	46	Safety Fuse, Definition.....	47
Residual Magnetism, Definition.....	46	Sag of Conductor or Line Wire	
Resin, Definition.....	46	Definition.....	47
Resistance, Dielectric, Definition.....	17	Copper Wire.....	714
Definition.....	46	Problems, Solution of.....	524
Effective, Alternating Current.....	205	Salts, for the Preservation of Wood	594
Effective, Definition.....	19	Sap-Wood.....	582
Equivalent, Definition.....	21	Saturation, Magnetic, Definition.....	37
Measurements, Transformers.....	357	Sawed Red Wood Poles, Dimensions of.....	132
Non-Inductive, Definition.....	40	Specification for.....	131
Ohmic, Definition.....	40	Scott Transformation-Vector Analysis.....	378
of Pipe Grounds.....	429	Screws Lag.....	279
Relative, Table of.....	191	Specification for Lag.....	279-281
Secondary, Definition.....	48	Season Checks.....	123
Specific.....	189	Seasoning Cross-Arms.....	565
Specific, Definition.....	49	Poles.....	565
Specific, Table of.....	191	Time Required for.....	574
Tests, Induction Regulators.....	386	Secondary Ampere-Turns, Definition.....	47
Track, Table of.....	251	Coil of Transformer-Definition of.....	47
Transformer Insulation.....	345	Connections, Single - Phase, Two-Wire System.....	443
Units of.....	189	Connections, Three-Phase, Four-Wire Systems.....	450
Units, Comparison of.....	189	Connections, Three-Phase, Three-Wire, Description.....	448
of Wires, Solid, Table of.....	221	Connections, Two - Phase, Four-Wire System.....	445
of Wire, Stranded, Table of.....	222	Connections, Two - Phase, Three-Wire System.....	445
Resistivity, Definition.....	46	Currents, Definition.....	47
Resonance, Definition.....	47	Definition.....	47
Resultant Load on Wire, Formulas for.....	527	Grounds.....	433
Magnetic Field, Definition.....	47	Resistance, Definition.....	48
Power-Factors.....	505	Winding, Definition.....	48
Resuscitation from Electric Shock.....	789	Wires, Stringing of.....	729
Right Handed Rotation, Definition.....	47	Secondaries, Grounding of.....	433
Rights-of-Way.....	683	Section Modulus, Table of.....	525
Back-Yard.....	683	Self-Inductance, Coefficient of, Definition of.....	11
Street.....	683	Induction, Definition.....	33-48
Ring Rot.....	124	Induction, Solid Wires, Table of.....	223
Shakes.....	124	Induction, Stranded Wire, Table of.....	225
Rock, Setting Poles In.....	687	Series A. C. System, Calculation of.....	482
Rods, Guy.....	282		
Rod, Lightning, Definition.....	36		
Rods, Specification for Guy.....	282-284		
Root-Mean-Square or Effective Value, Definition.....	47		
Rope, Messenger, Definition.....	38		
Rotation, Right-Handed, Definition.....	47		
Rotting of Wood, Causes of.....	583		

# INDEX

	PAGE		PAGE
Series A. C. system, Description of	450	Special Steel Strands, Table of	214
Series Circuit, Definition	10, 48	Strands, Table of Extra Galvanised	213
Connection, Definition	12	Specific Conductivity	190
Direct Current System, Method of Calculating	469	Definition	49
Distribution, Definition	48	Specific Inductive Capacity, Definition	49
Lighting System, Direct Current, Description of	440	Resistance	189
Lighting Transformers	378	Resistance, Definition	49
Multiple Circuit, Definition	48	Resistance, Table of	191
Service Wires, Definition	48	Spelter, Definition	49
Setting Poles	685	Specifications for Aerial Line Construction	674-749
in Quick-Sand	687	for Aluminum Cables, Weatherproof Insulated	257
in Rock	687	for Aluminum Wire, Weatherproof Insulated	257
Shearing Stress Formula	523	Analysis Coal Tar Creosote	624
Shell Type Transformers	320	Analysis of Mixed Oils, Wood Preservation	629
Shells, Definition	48	Analysis of Water-Gas-Tar Creosote	630
Sherardising, Description of	784	for Bare Aluminum Wires	257
Shock, Resuscitation from Electric Short Circuit, Definition	48	for Bare, Hard-Drawn Copper Wire	252
Simple Harmonic Electro-Motive Force, Definition	48	for Carriage Bolts	279-281
Periodic Current, Definition	15	for Chestnut Poles	125
Sine, Definition	48	for Circular Loom Covered, Tree Wire	259
Law, Definition	48	for Coal-Tar Creosote	621
Single Gap Lightning Arrester	404	for Copper Cables, Weatherproof Insulated	251
Single-Phase, Calculation of Regulator Capacity	503	for Creosoted Pine Cross-Arms	270, 637
Definition	48	for Creosoted Pine Poles	634
Load Connected to Polyphase System	498	for Creosoted Yellow Pine Poles	134
System, Definition	443	for Creosoting Pine Cross-Arms	638
System, Regulation of Regulators	501	for Creosoting Pine Poles	635
System, Three-Wire, Description of	443	for Cross-Arm Bolts	279-281
Three-Wire, System, Calculation of	477	for Cross-Arm Braces	279
Transmission, Vector Diagrams	454	for Eastern White Cedar Poles	127
Two-Wire Systems, Calculation of	474	for Galvanised Steel Strand	251
Two-Wire Systems, Description of	443	for Galvanising	784
Single-Pole Cut-out Definition	49	for Guy Rods	282-284
Sinusoidal Alternating Electro-Motive-Force, Definition	49	for Hard-Drawn Copper Clad, Steel Wire	254
Sinusoidal Curve, Definition	49	for Idaho Cedar	129
Skin Effect	205	for Lag Screws	279-281
Definition	49	for Mixed Oil, Wood Preservation	628
Factors, Table of	207	Oil for Brush Treatment	633
Sleet	767	for the Open-Tank Treatment of Pole Butts	640
Data, Table of	778	for Pole Steps	281, 282
Sleeve, Connecting, Definition	12	for Red Cedar	129
Joint, Definition	49	for Sawed Red Wood	131
Splicing, Definition	49	Transformers	363
Snow Storms	766	Transformer Oil	364
Soft Drawn Copper Wire, Definition	49	for Tree Wire	259
Solid Concrete Poles	135, 136	of Untreated Cross-Arms	267
Solution of Sag Problems	524	for Washers	279-281
Spacing of Poles	683	for Water-Gas-Tar Creosote	629
Sparking Distances	512	for Weatherproof Copper Wire	251
Special Cross-Arms	270		
Galvanised Strand	212		

# INDEX

PAGE	PAGE
Specifications for Western Cedar . . . . .	129
for Wood Insulator Pins . . . . .	272, 273
Wood Poles . . . . .	125
Wood Preservation, Auxiliary for Yellow Pine Poles . . . . .	630
Sphere Gaps . . . . .	133
Sparkling Distances, Table of . . . . .	514
Splicing Sleeve, Definition . . . . .	49
Structural Steel Poles . . . . .	159
Wires . . . . .	715
Split Phase, Definition . . . . .	49
Spray and Brush Discharge, Definition of . . . . .	7
Spreader Brackets . . . . .	720
Square Mill, Definition . . . . .	49
Stampings, Transformer, Definition . . . . .	52
Standard Conductivity, Matthiessen's . . . . .	190
Frequencies, Definition . . . . .	441
Pin Threading . . . . .	272
Steel Strands, Table of . . . . .	212
Star-Three-Phase System, Definition . . . . .	50
Static Discharge, Definition . . . . .	50
Electricity, Definition . . . . .	50
Steel Cross-Arms . . . . .	270
and Iron, Reduction of . . . . .	180
and Iron, Refining of . . . . .	180
Poles, Function of Bracing . . . . .	155
Poles, Patented . . . . .	147
Poles and Towers . . . . .	145
Poles and Towers, Comparison of Strength . . . . .	159
Poles, Tubular . . . . .	147
Reinforcing, Concrete Poles . . . . .	136
Strand, Galvanised, Specifications for . . . . .	251
Towers . . . . .	145
Towers, Function of Bracing . . . . .	155
Towers, Structural . . . . .	148
Tubular Poles, Table of . . . . .	145
Wire, Stranded, Table of loading . . . . .	536
Wire, Table of Physical Constants . . . . .	187
Steps, Pole . . . . .	281
Pole, Definition . . . . .	44
Specification for Pole . . . . .	281, 282
Step-Down Transformer, Definition . . . . .	50
Step-Up Transformer, Definition . . . . .	50
Storing Cross-Arms . . . . .	566
Poles . . . . .	566
Storm Movements . . . . .	755
Strain, Definition . . . . .	50
Insulators . . . . .	289
Insulator, Definition . . . . .	50
Insulators, Globe, Definition . . . . .	23
Strand, Galvanised Steel, Specifications for . . . . .	251
Stranded Conductor, Definition . . . . .	50
Strands, Special Galvanised . . . . .	212
Table of Standard Steel . . . . .	212
Wire . . . . .	197
Stray Currents, Definition . . . . .	50
Field, Definition . . . . .	50
Street Crossings . . . . .	683
Rights-of-Way . . . . .	683
Strength of Concrete . . . . .	139
Current, Definition . . . . .	50
Rotted Poles, Calculation of . . . . .	553
Timber, Table of . . . . .	524
Stress, Definition . . . . .	50
Stresses on Cross-Arms, Calculation of . . . . .	547
in Poles, Calculation of . . . . .	549
Structural Steel Poles . . . . .	148
Failure of . . . . .	151
Loading of . . . . .	149
Towers . . . . .	148
Towers, Failure of . . . . .	151
Towers, Loading of . . . . .	149
Structure of Wood . . . . .	578
Stub, Ground . . . . .	162
Guying . . . . .	701
Submarine Cable, Definition . . . . .	8
Sub-Stations, Outdoor . . . . .	163
Surface Density, Definition . . . . .	50
Surges, due to Internal Conditions . . . . .	396
Lightning . . . . .	393
Surges and Oscillations, Causes . . . . .	396
Surging Discharge, Definition . . . . .	50
Surgings, Electric, Definition . . . . .	50
Sum, Vector, Definition . . . . .	53
Supply Mains, Definition . . . . .	50
Suspension Insulators . . . . .	289
Calculated Characteristics . . . . .	308
Capacity . . . . .	304
Effective Capacity . . . . .	304
Voltage Distribution . . . . .	302
Voltage Distribution Dry Arc-Over . . . . .	311
Voltage Distribution Wet Arc-Over . . . . .	311
Switches . . . . .	413
Air-Break . . . . .	413
Switch, Automatic, Definition of . . . . .	6
Switches, Oil-Break . . . . .	417
Switch, Time, Definition . . . . .	52
Synchromism, Definition . . . . .	50
Synchroscope, Definition . . . . .	51
Series System, Direct Current, Thury, Description of . . . . .	440
Systems of Distribution . . . . .	722
System, Low Potential, Definition . . . . .	37
Quarter-Phase, Definition . . . . .	45
Star Three-Phase, Definition . . . . .	50
Three-Wire, Definition . . . . .	52
T	
Table of Absorption of Creosote, Western Red Cedar . . . . .	662
Air Density, Correction Factor . . . . .	487
Aluminum Wire, Physical Constants . . . . .	185
Aluminum Wire, Special Sizes . . . . .	247

# INDEX

PAGE	PAGE
Table of Annual Service Charge, Western Yellow Pine..	660
Average Life of Poles...	672
B. & S. Gauge, Cross-Section Area of Wires...	196
B. & S. Gauge, Diameter of Wire .....	196
Barometric Corrections...	783
Bending Moment Formulas	526
Breaking Strength of Wire, Solid .....	215
Breaking Strength of Wires, Stranded .....	216
Capacity, Solid Wire...	226
Capacity of Stranded Wire	228
Charging Current, Solid Wire .....	238
Charging Current, Stranded Wire .....	244
Circumferences and Areas of Circles .....	95-99
Comparative Costs of Preservation Western Yellow Pine .....	661
Comparative Wire Gauge.	195
Conversion .....	102-104
Copper Clad Wire, Physical Constants .....	186
Copper Wire, Physical Constants .....	184
For Correcting Wind Velocities .....	781
Cost of Treating Timber.	674
Current Carrying Capacity of Wire .....	204
Decimal Equivalents .....	94
Deflection Formula .....	526
Diameters of Wire, Solid.	217
Diameters of Wire, Stranded .....	218
Extra Galvanized Special Strands .....	213
Fusing Effects of Currents	199
Green Weights, Loblolly Pine .....	576
Heating Effects of Current	202
Inductive Reactance, Solid Wire .....	229
Inductive Reactance, Stranded Wire .....	235
Iron Wire, Physical Constants .....	188
Line Loss, Explanation of Loading, Aluminum Wire, Stranded Bare .....	472
Loading, Bare Copper Wire, Solid .....	539
Loading, Copper Wire, Solid, Insulated .....	540
Loading, Copper Wire, Stranded, Bare .....	538
Logarithms of Numbers.	59-83
Maximum Recorded Wind Velocities .....	772
Table of Moment of Inertia Formulas .....	525
Monthly Mean Maximum Temperatures .....	768
Monthly Mean Minimum Temperature .....	769
Natural Trigonometric Functions .....	85-91
Number of Days with Dense Fog .....	776
Number of Days Maximum Wind Velocity Above 40 Miles .....	774
Number of Days with Minimum Temperature Below Zero .....	771
Number of Days with Temperature Above 90 Degrees .....	770
Number of Thunderstorms	775
Oil Preservatives, Comparison .....	595
Physical Constant, Aluminum Wire .....	185
Physical Constants, Copper Clad Wire .....	186
Physical Constants, Copper Wire .....	184
Physical Constants, Iron Wire .....	188
Physical Constants, Steel Wire .....	187
Pole Settings .....	685
Poles Treated with Different Preservatives ..	666-667
• Pole Treatment, Western Yellow Pine ..	555-56-58-59
Power Factors, Various Types of Loads .....	506
Properties, Wire Material	537
Radius of Gyration .....	525
Relative Conductivity .....	191
Relative Resistance .....	191
Resistance of Wire, Solid.	221
Resistance of Wire, Stranded .....	222
Sag of Annealed Copper-Line Wire .....	714
Seasoning, Arbor Vite ..	576
Seasoning Chestnut .....	575
Seasoning, Loblolly Pine ..	577
Seasoning, Western Red Cedar .....	575
Seasoning, Western Yellow Pine .....	574
Section Modulus .....	525
Self-Induction, Solid Conductors .....	223
Self-Induction, Stranded Wire .....	225
Skin Effect Factors .....	207
Sleet Data .....	778
Sparking Distances, Needle Points .....	513

# INDEX

PAGE	PAGE
Table of Sparking Distances, Sphere Gaps .....	514
Special Steel Strands .....	214
Specific Resistance .....	191
Standard Steel Strands .....	212
Steel Tubular Poles .....	146
Steel Wire, Physical Constants .....	187
Stranded Steel Wire, Loading of .....	536
Strength of Timber .....	524
Temperature Coefficients .....	192-194
Track Resistance .....	251
Treated Poles, Length of Life .....	668-670
Weights of Wire, Solid .....	219
Weights of Wire, Stranded .....	220
Tap, Definition .....	51
Taps to Line Wire .....	720
Tangent, Definition .....	51
Temperature, Absolute, Definition of .....	3
Coefficient .....	191-193
Coefficient, Definition .....	51
Coefficient, Tables of .....	192-194
Definition .....	51
Maximum, Table of Monthly Mean .....	768
Minimum Monthly Mean .....	769
Transformers .....	334
Tension Formulas .....	523
Terminals of Line Wire .....	720
Terminal Voltage, Definition .....	51
Tertiary Coils .....	382
Test, Electrical Insulators .....	299-301
Induction Regulator .....	385
Loop, Definition .....	37
Mechanical Insulators .....	301
Voltage-Measuring of .....	349
Testing of Ground Connections of Insulators .....	433
Transformer .....	299
Transformer .....	345
Thermometric Scale, Fahrenheit, Definition .....	21
Three-Phase, Definition .....	51
Four-Wire System, Calculation of Regulator Capacity .....	504
Four-Wire System, Description .....	448
Four-Wire System, Regulation of Regulators .....	503
System, Calculation of .....	478
Systems, Definition .....	445
System, Vector Diagram .....	457
Three-Wire System, Calculation of Regulator Capacity .....	504
Three-Wire System, Description .....	445
Three-Wire System, Regulation of Regulators .....	502
Three-Phase Transformer, Definition .....	52
Three-Wire, Edison System, Method of Calculating .....	469
Mains, Definition .....	52
Single-Phase System, Description of .....	443
System, Definition .....	52
System, Edison, Description .....	440
Three-Phase System, description .....	445
Two-Phase System, description of .....	443
Thunderstorms .....	764
Table of Total Number .....	775
Thury Direct Current Series System, Description of .....	440
Tie Wires .....	714
Definition .....	52
Time-Constant of Circuit, Definition .....	52
Required for Seasoning .....	574
Switch, Definition .....	52
Timber, Table of Strength .....	524
Torsion Formulas .....	524
Towers, Flexible .....	160
Steel .....	145
Structural Steel .....	148
Track Resistance, Table of .....	251
Transformers, Ageing of .....	321
Air-Core, Definition of .....	3
Auto, Definition of .....	319
Balancer, Definition .....	52
Capacity, Calculation of .....	494
Cases .....	324
Cases, Grounding of .....	433
Characteristics .....	345
Coils .....	321
Constant Current, Definition of .....	319
Construction .....	319
Copper Losses .....	330
Copper Loss Test .....	359
Cores .....	320
Core, Ageing of, Definition of .....	3
Core Loss Test .....	355
Core Type .....	320
Cruciform Type .....	321
Definition .....	52
Design .....	333
Eddy Current Losses .....	329
Efficiency .....	335
Efficiency, Calculation of .....	500
Equations .....	327
Exciting Current .....	330
Exciting Current Test .....	355
Heating Test .....	350
Hysteric Losses .....	329
Induced Voltage .....	331
Installation of .....	729
Insulation .....	334
Insulation-Testing of .....	345



# INDEX

PAGE	PAGE
Transformers, Method of Erection .....	733
Oil Duct .....	824
Oil Specifications .....	364
Operation .....	366
Over Potential Test .....	350
Parallel, Connecting of .....	368
Polarity Test .....	362
Polyphase .....	367
Power-factor .....	340
Primary Coil of, Definition .....	44
Ratio .....	332
Ratio, Test of .....	861
Reactance Drop .....	360
Regulation .....	336
Regulation, Calculation of .....	498
Regulation, Test of .....	861
Resistance Measurements .....	857
Temperature .....	334
Testing .....	345
Three-Phase, Definition .....	52
Scott, Vector Analysis .....	378
Secondary Coil of, Definition .....	47
Series Lighting .....	378
Shell Type .....	320
Specifications .....	363
Stampings, Definition .....	52
Step-Down, Definition .....	50
Step-Up, Definition .....	50
Transformation, Ratio of, Definition .....	45
Transmission Circuit, Electric, Definition .....	52
Constant Voltage .....	511
Economics of .....	506
Electric-Definition .....	52
Line Calculation, Effect of Charging Current .....	460
Line Calculation, Formulse .....	462
Line, Choice of Voltage .....	484
Line, Electric Charges on, Causes .....	393
Lines, Grounding Wires on .....	411
Line Losses, Methods of Calculating .....	464
Line Transposition .....	509
Polyphase, Definition .....	44
Systems, Description of .....	439
Three-Phase, Definition .....	52
Transposition .....	509
Transposing, Definitions .....	53
Traveling Waves of Potential .....	894
Treating Cross-arms .....	690
Tree Guying .....	706
Insulators .....	713
Trimming .....	712
Wire, Circular Loom Covered, Specification for .....	259
Wire, Specification for .....	259
Trigonometric Functions, Natural; Tables of .....	85-91
Trimming Poles .....	681
Triple Braid, Weatherproof Solid Wire, Diameters of .....	217
Weatherproof Wire, Solid, Weights of .....	219
Weatherproof Wire, Stranded, Diameters of .....	218
Weatherproof Wire, Stranded, Weights of .....	220
Triple Petticoat Insulator, Definition .....	53
Tubular Poles, Steel, Table .....	146
Steel Poles .....	147
Steel Poles, Use of .....	147
Two-Phase, Definition .....	53
System, Definition of .....	443
Five-Wire System, Description .....	445
Four-Wire System, Description .....	445
Four-Wire System, Vector Diagram .....	455
System, Calculation of Regulator Capacity .....	503
System, Regulation of Regulators .....	502
Three-Wire System, Calculation of .....	477
Three-Wire System, Description of .....	443
Three-Wire System Vector Diagram .....	456
Two-Wire Direct Current System, Description of .....	439
Mains, Definition .....	53
Single-Phase System, Description of .....	443
System, Direct Current, Method of Calculating .....	464
Types of Loads, Power-Factors of .....	505
Metal Pins .....	274-278
<b>U</b>	
Units, Electrostatic Capacity, Definition .....	9
Electrostatic, Definition .....	20
Fundamental .....	102-104
Heat, Definition .....	31
Magnetic, Definition .....	38
Metric .....	103-104
of Resistance .....	189
Resistance, Comparison of .....	189
Use of Tubular Steel Poles .....	147
<b>V</b>	
Various Types of Loads, Power-Factors of .....	505
Varnish, Insulating, Definition .....	34
Vectors .....	451
Additions .....	454

# INDEX

PAGE	PAGE
<b>Vectors, Analysis, Scott Trans-</b>	<b>Weight of Wire and Ice, Form-</b>
formation . . . . . 378	mulae for . . . . . 527
Description of . . . . . 452	<b>Wellhouse Process of Wood</b>
Diagrams . . . . . 451	Preservation . . . . . 600
Diagram, Definition . . . . . 53	<b>Western Cedar Poles, Dimen-</b>
Diagrams, Single-Phase	sions of . . . . . 130
Transmission . . . . . 454	Specifications for . . . . . 129
Diagram, Three-Phase System	<b>Western Red Cedar, Absorp-</b>
. . . . . 457	tion of Creosote . . . . . 662
Diagram, Two-Phase, Four-	Fire Killed Poles . . . . . 117
Wire System . . . . . 455	Logging of . . . . . 114
Diagram, Two-Phase,	Tank Treatment with Cre-
Three-Wire System . . . . . 456	osote . . . . . 661
Plane, Definition . . . . . 43	Time of Cutting . . . . . 116
Quantity, Definition . . . . . 53	Where Grown . . . . . 114
Sum, Definition . . . . . 53	<b>Western Yellow Pine, Annual</b>
<b>Velocity, Angular, Definition</b>	Service Charge, Wood
of . . . . . 5	Preservation . . . . . 660
<b>Vibration of Wave, Amplitude</b>	Comparative Cost of Treat-
of . . . . . 5	ment . . . . . 661
<b>Volt, Definition . . . . . 54</b>	Logging of . . . . . 119
<b>Volt-Ampere, Definition . . . . . 59</b>	Time of Cutting . . . . . 121
<b>Voltage Distribution, Wet Arc-</b>	Treated with Creosote . . . . . 656
<b>over, Suspension Insula-</b>	Treated with Crude Petro-
tors . . . . . 311	leum . . . . . 658
Distribution, Suspension	Treated with Zinc Chlor-
Insulators . . . . . 802	ide . . . . . 659
Distribution, Dry Arc-over	Where Grown . . . . . 119
Suspension Insulators . . . . . 311	<b>Western White Cedar Poles,</b>
Drop of, Definition . . . . . 18	Dimensions of . . . . . 130
Regulator . . . . . 501	Specification for . . . . . 129
Terminal, Definition . . . . . 51	<b>Wet and Dry Process, Porce-</b>
on Transmission Lines,	lain Insulators, Relative Ad-
Choice of . . . . . 484	vantage of . . . . . 292
<b>Voltmeter, Iron Loss . . . . . 356</b>	<b>Wet Process, Porcelain Insu-</b>
<b>Vulcanizing Rubber . . . . . 182</b>	lators . . . . . 291
<b>W</b>	<b>White Cedar Logging . . . . . 111, 112</b>
<b>Washers . . . . . 279</b>	Time of Cutting . . . . . 111
Specification for . . . . . 279-281	Where Grown . . . . . 111
<b>Water-Gas-Tar, Creosote . . . . . 592</b>	<b>Wind Pressure, Formulae . . . . . 523</b>
Production of . . . . . 592	on Wires, Formulae for . . . . . 527
Specification of . . . . . 629	<b>Wind Shakes . . . . . 124</b>
<b>Water Pipe Grounds . . . . . 433</b>	Velocities, Table for Cor-
<b>Watt, Definition . . . . . 55</b>	recting . . . . . 781
<b>Watt-Hour, Definition . . . . . 55</b>	Velocities, Table of Maxi-
<b>Wattless Component of Electro-</b>	mum Recorded . . . . . 772
<b>motive-Force, Definition . . . . . 55</b>	<b>Winding, Concentric . . . . . 323</b>
<b>Wave, Complete, Definition . . . . . 11</b>	Interleaved . . . . . 323
Electric, Definition . . . . . 55	Pancake . . . . . 323
<b>Waves, Traveling . . . . . 394</b>	Secondary, Definition . . . . . 48
<b>Weather Map . . . . . 756</b>	<b>Wire Aluminum, Stranded</b>
Interpretation of . . . . . 758	Bare, Table of Loading . . . . . 541
Symbols . . . . . 755	<b>Wire Aluminum, Table of</b>
<b>Weatherproof Insulation . . . . . 181</b>	Physical Constants . . . . . 185
Insulation, Definition . . . . . 55	Aluminum Weatherproof
Wire, Definition . . . . . 55	Insulated, Specification
<b>Weight of Conductors, Elec-</b>	for . . . . . 257
<b>trical System, Compara-</b>	Attached to Structure . . . . . 711
<b>tive . . . . . 450</b>	Bare Aluminum, Specifica-
of Wires, Stranded, Table	tion for . . . . . 257
of . . . . . 220	Bare Copper, Solid, Table
of Wire, Solid, Table of . . . . . 219	of Loading . . . . . 539
	Bare Hard-Drawn Cop-
	per, Specification for . . . . . 252

# INDEX

	PAGE		PAGE
Wire, Bimetallic, Definition . . .	7	Wire Manufacture of, Rubber	
Braided, Definition . . . . .	7	Insulation . . . . .	181
Breaking Strength of		Manufacture of, Vul-	
Solid, Table of . . . . .	215	canizing . . . . .	182
Breaking Strength of		Manufacture of, Weather-	
Stranded, Table of . . . . .	216	proof Insulation . . . . .	181
Cap. Definition . . . . .	8	Manufacture of, Wire	
Capacity of Solid, Table		Drawing . . . . .	181
of . . . . .	226	Manufacture of, Work-	
Capacity of Stranded,		ing Ingots . . . . .	181
Table of . . . . .	228	Materials, Table of Prop-	
Carrying Capacity of . . . . .	722	erties . . . . .	537
Charging Current of Solid,		Percentage Conductivity	
Table of . . . . .	238	of, Definition . . . . .	41
Charging Current of		Positive, Definition . . . . .	44
Stranded, Table of . . . . .	244	Reinforcing of . . . . .	721
Clearance . . . . .	711	Resistance of Solid, Table	
Composite, Definition . . . . .	11	of . . . . .	221
Copper, Table of Physical		Resistance of Stranded . . . . .	222
Constants . . . . .	184	Rubber Insulated, Tree,	
Copper, Bare, Stranded,		Specification for . . . . .	259
Table of Loading . . . . .	538	Running Through Trees . . . . .	713
Copper Clad, Table of		Self-Induction of Stranded,	
Physical Constants . . . . .	186	Table of . . . . .	225
Copper, Solid Insulated,		Sizes to Be Used . . . . .	709
Table of Loading . . . . .	540	Solid, Self-Induction,	
Copper, Specifications for		Table of . . . . .	223
Weatherproof, Insulated	251	Splicing . . . . .	715
Copper, Table of Current		Steel, Table of Physical	
Carrying Capacity . . . . .	204	Constants . . . . .	187
Definition . . . . .	55	Stranded Steel, Loading	
Diameter of, Solid, Table		of . . . . .	536
of . . . . .	217	Strands . . . . .	197
Diameter of, Stranded,		Stringing of Secondary . . . . .	729
Table of . . . . .	218	Support of . . . . .	711
Drawing . . . . .	181	Tables . . . . .	184
Duplex, Definition . . . . .	18	Tie . . . . .	714
Gauge, American, Defini-		Weatherproof, Definition . . . . .	55
tion of . . . . .	4	Weights of, Solid, Table	
Gauge, Micrometer, Def-		of . . . . .	219
inition . . . . .	88	Weights of, Stranded,	
Gauges . . . . .	195	Table of . . . . .	220
Gauges, Comparison of . . . . .	195	Wiring of Corner Poles . . . . .	720
Guy, Definition . . . . .	25	of Poles . . . . .	720
Guy . . . . .	701	Wood Creosote . . . . .	594
Hard-drawn Copper, Defi-		Cross-Arms . . . . .	267
nition . . . . .	26	Cross-Arms, Specification	
Hard-Drawn, Copper Clad		of . . . . .	267
Steel, Specifications for . . . . .	254	Decay of . . . . .	583
Inductive Reactance of		Heart . . . . .	582
Solid, Table of . . . . .	229	Insulator Pin, Specifica-	
Inductive Reactance of		tion for . . . . .	272, 273
Stranded, Table of . . . . .	235	and Metal Pins . . . . .	274
Insulated, Definition . . . . .	34	Pins . . . . .	270-272
Insulation . . . . .	711	Poles . . . . .	111-135
Iron, Table Physical Con-		Pole Defects . . . . .	123
stants . . . . .	188	Pole Specifications . . . . .	125
Live, Definition . . . . .	87	Porcelain and Metal Pins . . . . .	274
Location on Pole . . . . .	722	Wood Preservation . . . . .	561
Manufacture of, Applica-		Absorption Results . . . . .	660
tion of Rubber Com-		Alternate Hot and Cold	
pound . . . . .	182	Treatment . . . . .	605
Manufacture of, Protection		Analysis Specification	
of Rubber Insulation . . . . .	183	Water-Gas-Tar Creosote . . . . .	630

# INDEX

	PAGE		PAGE
Wood Preservation, Auxiliary Specifications .....	630	Wood Preservation, Western Red Cedar, Creosote and Zinc Chloride....	664
Brush Combined with Open Tank.....	610	Western Red Cedar, Crude Petroleum .....	663
Brush Treatment ...	608, 650	Western Red Cedar, Zinc Chloride .....	663
Choice of Preservatives..	619	Wood Preservative Agents....	585
Comparative Costs of Treatment .....	661	Analysis Specification, Coal-Tar-Creosote .....	624
Hot Treatment .....	602	Coal-Tar-Creosote .....	587
Jacket or Butt Settings..	610	Comparison of .....	664
Low Artificial Pressure System .....	607	Salts .....	594
with Oils .....	586	Water-Gas-Tar Creosote ..	592
Open Tank Plants, Description of .....	641	Wood Creosote .....	594
Open Tank Pole Treatments, Western Yellow Pine .....	655	Wood, Sap .....	582
Open Tank Treatment... ..	607	Structure of .....	578
Open Tank Treatment of Pole Butts .....	640	Work, Definition .....	55
Petroleum Oil .....	594	Working Ingots .....	181
Plants .....	597	Y	
Process for .....	596	Y-Connector, Definition .....	56
Specification for Analysis of Mixed Oils.....	629	Y-Current, Definition .....	56
Specification Coal-Tar Creosote .....	621	Y and "Δ" Transformer Connections, Comparison of....	450
Specification for Mixed Oils .....	628	Yellow Pine Poles, Dimensions of .....	183
Specification for Oil for Brush Treatment .....	633	Specification for .....	183
Specification of Water-Gas-Tar Creosote .....	629	Specification for Creosoted .....	184
Steeping in Cold Preservatives .....	602	Z	
Western Red Cedar .....	661	Zinc, Definition .....	56
		Plating, Definition .....	57

